

GS series and DURAPULSE AC Drives

Section 13



STELLAR
soft starter

Soft Starters

Section 14



General Purpose Motors, Inverter Duty Motors, Worm Gearboxes, DC Motors

Section 15



IRONHORSE

MARATHON

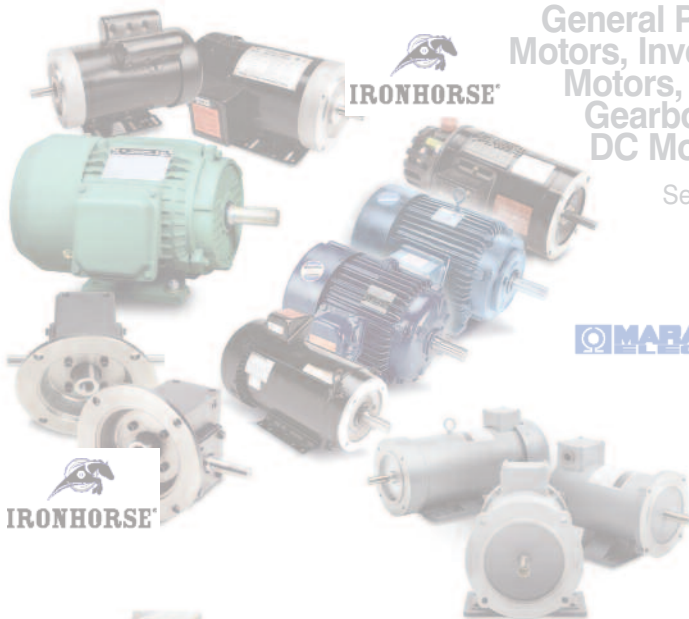

Steppers and Servos

Section 16

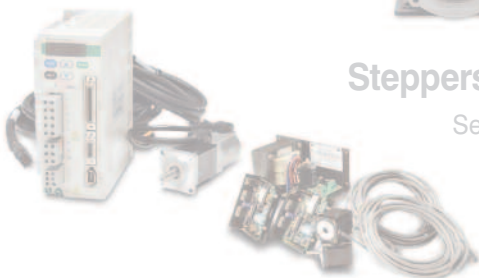

In this interactive PDF you can:

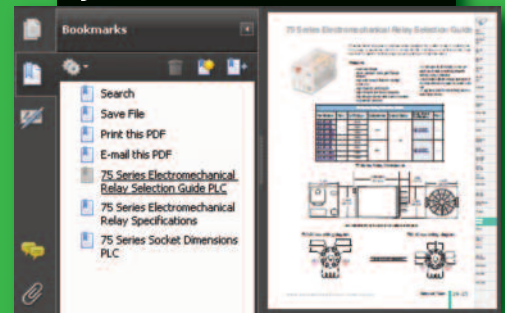

- Use bookmarks to navigate by product category
- Use bookmarks to save, search, print or e-mail the catalog section
- Click on part #s to link directly to our online store for current pricing, specs, stocking information and more



Volume 14
e14-1

The Stellar Advantage

Why use a soft starter instead of electromechanical contactors to control 3-phase AC induction motors?

Reduce mechanical wear and tear

- Smooth acceleration; reduced shock and starting stress
- Extend lifespan of mechanical drive train components
- Fluid couplings and some clutches can be eliminated

Increased electrical efficiency

- Reduced starting current
- More motors or larger motors can be started from lower-capacity power sources
- Allows motors to be started more frequently
- SR22 and SR33 only - Internal mechanical bypass contacts open and close under reduced current, increasing lifespan and reliability

Cost savings

- Lower overall costs for new installations
- Reduced maintenance and replacement of mechanical drive train components
- Reduced starting current reduces electrical power costs
- SR44 only - Energy Optimizing mode reduces electrical power costs
- SR44 only - Automatic Application setup feature speeds installation by configuring the SR44 for a specific application with one setting.

The SR33 series is an ideal substitute for a Star/Delta starter because it fits into a similar footprint, thus simplifying installation. The SR33 soft starters use thyristors for controlled reduced voltage motor starting and stopping, then switch to internal bypass contacts for efficient running at rated speed.

This series is designed to fit in place of existing wye-delta starters. 3-potentiometer setup (Start Voltage, Start Time, and Stop Time) make installation and commissioning easy.

Features

- 22-482A @ 208-230/460 VAC
- 24 VDC or 115 VAC I/O
- 24 VDC control power required
- Two-phase control
- Internal bypass contacts for Run
- Easily and separately adjustable motor start voltage and start and stop times
- Suitable for a wide variety of motor loads
- Designed to replace wye-delta starters
- Fault indication of 4 or 7 fault types, depending upon model.
- IP20 (SR33-22 to SR33-97)
- IP00 (SR33-132 to SR33-482) panel mount
- Two-year warranty

Stellar® Series Soft Starters



Our Stellar Series of soft starters are designed to help you reduce mechanical wear and tear on startup, reduce energy costs and help you minimize loss of production hours from equipment breakdown.

When to use a soft starter?

General purpose soft start applications where traditional across-the-line starting or wye-delta starting would typically be appropriate. Stellar soft starters should not be used if the starting time will exceed 30 seconds.

Why purchase your soft starter from AutomationDirect?

- **Our soft starters are IN-STOCK and ready to ship**
- **FREE 2-day delivery when you order \$300 or more**
- **FREE 30-day money-back guarantee**
- **FREE #1 voted tech support**
- **VALUE PRICING on everything we sell - you'll always get our best price whether you order 1 or 100 items**

3-Phase Basic Soft Starters up to 400 hp! SR33 Series, 22A - 482A



Energy Optimizing and Efficient, Full-Featured 3-Phase Soft Starters

SR44 Series, 9A - 370A



SR44 full-featured solid-state Soft Starters provide many advantages when used instead of electromechanical contactors to control 3-phase AC induction motors. The SR44 Soft Starters are fully digital, and use thyristors in all three motor phases for controlled reduced voltage motor starting and stopping. SR44s have an Automatic Application Setup that fully configures the starter for a specific application with one entry. SR44s also have a built-in "Optimizing" mode that reduces energy costs when used on lightly loaded or oversized motors, and external bypass capability for efficient running at rated speed.

Features

- **Advanced energy-saving Optimizing Mode improves motor efficiency and power factor, prolongs motor life**
- **Can be connected 'in-the-delta', allowing use of a smaller Soft Starter**
- **9-370A @ 230-460VAC**
- **Full three-phase motor control**
- **Can be controlled via Local Keypad, Digital Inputs, optional Remote Keypad, or optional Modbus Communications.**
- **115/230VAC or 12/24VDC control inputs**
- **Fault record history of last 5 trips**
- **Two-year warranty**

Compact 3-Phase Soft Starters at Direct Prices

SR22 Series, 5A - 40A



The SR22 series is a low-cost family perfect for use in applications where space is a concern. The SR22 soft starters use thyristors for controlled reduced voltage motor starting and stopping, then switch to internal bypass contacts for efficient running at rated speed. 3-potentiometer setup (Start Voltage, Start Time, and Stop Time) make installation and commissioning easy.

Features

- **5-40A @ 208-460V**
- **24 VDC control voltage**
- **Easily and separately adjustable motor start and stop times**
- **Two-phase control**
- **Internal bypass contacts for run**
- **DIN rail mounting**
- **Two standard-size widths: 45 & 55 mm**
- **Six error/trip indications: AC Supply, Control Supply, Overheated, Bypass Failure, Shear Pin, Overcurrent**
- **Two-year warranty**

Stellar® SR22 Series Compact Soft Starters

Overview

SR22 semi-conductor soft starters provide many advantages when used instead of electro-mechanical contactors to control 3-phase AC induction motors. The SR22 soft starters use thyristors for controlled reduced voltage motor starting and stopping, then switch to internal contacts for efficient running at rated speed.

Features

- 5–40A @ 208–460V
- 24 VDC control voltage
- Easily and separately adjustable motor start and stop times
- Two-phase control
- Internal bypass contacts for run
- DIN rail mounting
- Two standard-size widths: 45 & 55 mm
- Six error/trip indications: AC Supply, Control Supply, Overheated, Bypass Failure, Shear Pin, Overcurrent

Advantages

Mechanical Advantages

- Smooth acceleration; reduced shock and starting stress
- Extend lifespan of mechanical drive train components
- Fluid couplings and some clutches can be eliminated

Electrical Advantages

- Reduced starting current
- More motors or larger motors can be started from lower-capacity power sources
- Allows motors to be started more frequently
- Internal mechanical contacts open and close under reduced current, increasing lifespan and reliability

Economic Advantages

- Lower overall costs for new installations
- Reduced maintenance and replacement of mechanical drive train components
- Reduced starting current reduces electrical power costs

Standards & Approvals

- CE
 - RoHS
 - UL listed* (E333109)
- * (optional fans are UL recognized: E132139, E77551, E89936)

Optional accessories

- Cooling fan (increases # of starts/hour)

Applications

- General purpose applications where traditional across-the-line starting or wye-delta starting would typically be appropriate.



SR22 Series Compact Soft Starters *									
Model	SR22-05	SR22-07	SR22-09	SR22-12	SR22-16	SR22-22	SR22-30	SR22-36	SR22-40
Price	<--->	<--->	<--->	<--->	<--->	<--->	<--->	<--->	<--->
* Rated Current [class 5 starting] (A)	5	7	9	12	16	22	30	36	40
Rated Operational Voltage	208–460 VAC (-15% +10%) @ 50–60 Hz (±2Hz); 3 phase (2 phases controlled)								
* Motor Rating	Refer to selection table. Starters must be sized according to HP AND starting class.								
Impulse Withstand Voltage	2.5 kV								
Insulation Voltage Rating	500V								
Short Circuit Current Rating	5kA Type 1 when protected by recommended semiconductor fuses								
Control Power	approx 4VA @ 24 VDC (external power supply required) (UL applications require max 4A UL listed fuse)								
Control Inputs	galvanically isolated opto-coupled inputs; require sourcing +24 VDC (control)								
Auxiliary Relay Output	250 VAC: 2.5A resistive, 0.2A inductive / 30 VDC: 3.0A resistive, 0.7A inductive								
Start Time Setting Range	1–30 seconds								
Start Voltage Setting Range	30–100%								
Stop Time Setting Range	0–30 seconds								
Start Duty	3 x full load current for 5 seconds @ standard rating								
Starts / Hour (standard)	[10 starts / hr] OR [(5 starts / hr) + (5 soft stops / hr)]								
Starts / Hour (with optional fan)	[60 starts / hr] OR [(30 starts / hr) + (30 soft stops / hr)] internally bypassed								
Ambient Operating Temperature	0–40 °C [32–104 °F] – Above 40 °C [104 °F] derate linearly by 2% of unit FLC per °C to a max derate of 40% @ 60 °C [140 °F] *** NOT UL TESTED ABOVE 40 °C ***								
Transportation & Storage Temperature	-25–60 °C [-13–140 °F]								
Humidity	max 85% non-condensing; not exceeding 50% @ 40 °C [104 °F]								
Altitude	1000m [3281 ft]; 1000–2000m [3281–6562 ft] derate 1% of unit FLC per 100–2000m [328–6562 ft]								
Environmental Rating	IP20								
Shipping Weight	400g [14 oz]					680g [24 oz]		725g [26 oz]	
Dimensions [HxWxD]	143 x 45 x 117.8 mm [5.63 x 1.77 x 4.64 in]					167.5 x 55 x 117.8 mm [6.59 x 2.17 x 4.64 in]			
Accessories									
Cooling Fan (temperature controlled) **	SR22-FAN-45					SR22-FAN-55			
Price	<--->					<--->			
Dimensions	does not add to soft starter overall dimensions					adds 10 mm [0.39 in] to soft starter H dimension			
* Refer to Selection Table for deratings by application and overload trip class.						** Cooling fans do not run continuously.			

Stellar® SR22 Series Compact Soft Starters

SR22 Soft Starter Selection

- ① Determine the required trip class based on the motor load and required start time.
- ② Select the applicable SR22 part number based on the required Trip Class and motor HP.
- ③ Check application duty rating. (Frequency of motor starts can be increased by installing an optional soft-starter cooling fan, SR22-FAN-xx.)

The standard range for the SR22 is Trip Class 5, which means that it is capable of withstanding three times Full Load Current for five-second starts. For applications where longer starts are required, the SR22 has four additional ratings: Class 10B, Class 10, Class 20, and Class 30. These ratings correspond to IEC thermal/electronic overload trip classes.

A separate overload protection device with a rating corresponding to the applicable trip class must be used with the SR22 soft starter.

SR22 Soft Starters – O/L Trip Classes ①	
Default	5
Heavy	20
Agitator	10
Air Compressor - Equalized	5
Air Compressor - Loaded	20
Ball Mill	20
Centrifuge	n/a
Chiller	10B
Conveyor - Unloaded	5
* Conveyor - Loaded	20
Crusher	30
Escalator	10B
* Fan - Low Inertia < 85A	10
* Fan - High Inertia > 85A	30
Feeder - Screw	10
Grinder	20
Hammer Mill	20
Lathe Machine	10B
Mills - Flour, etc.	20
Mixer - Unloaded	5
Mixer - Loaded	20
Pelletizer	20
Plastic and Textile Machines	10B
Press - Flywheel	20
* Pump - Centrifugal	10B
* Pump - Positive Displacement - Unloaded	10
Rolling Mill	20
Saw - Band	10
Saw - Circular	20
Screen - Vibrating	20
Transformer, Voltage Regulator	10B
Tumbler	10
Wood Chipper	30
* Commonly required applications	

SR22 Soft Starters – Selection Table ② *								
Motor Horsepower			Application Trip Class					
HP @ 208V	HP @ 230V	HP @ 460V	Class 5**	Class 10B	Class 10	Class 20	Class 30***	
1	1	3	SR22-05	SR22-07	SR22-09	SR22-12	SR22-16	
1.5	2	3	SR22-07	SR22-09	SR22-12	SR22-16	SR22-22	
3	3	5	SR22-12	SR22-22	SR22-30	SR22-36	SR22-40	
3	3	7.5	SR22-12	SR22-22	SR22-30	SR22-36	SR22-40	
3	5	10	SR22-16	SR22-22	SR22-30	SR22-40	SR22-40 + fan	
5	7.5	15	SR22-22	SR22-30	SR22-40	SR22-40 + fan	n/a	
7.5	10	20	SR22-30	SR22-40	SR22-40 + fan	n/a	n/a	
10	10	25	SR22-36	SR22-40 + fan	n/a	n/a	n/a	
10	15	30	SR22-40	n/a	n/a	n/a	n/a	

* A separate overload protection device with a rating corresponding to the applicable trip class must be used with the SR22.
 ** Do not use the Class 5 rating when there is a possibility of the motor starting under a heavy load.
 *** The SR22 is not suitable for very high inertia loads such as centrifuges or loaded crushers with start times > 30s.

SR22 Soft Starters – Duty Rating ③ *		
Cooling Fan	Motor Start Frequency (starts/hr)	
	Class 5	Class 10B to Class 30
without fan	10 / hr	5 / hr
with SR22-FAN-xx	60 / hr	30 / hr

* @ 40 °C [104 °F] ambient temperature

SR22 Internal Overcurrent Trip Curve

The internal overcurrent trip of the soft starter does not replace the required external overcurrent device.

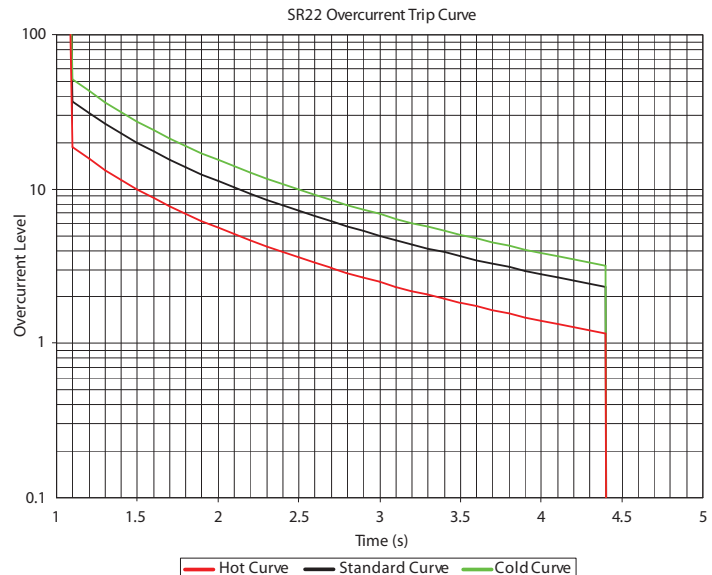

SR22 Max UL Overcurrent Protection

UL Maximum Overcurrent Protection Devices * for 5kA @ 480V Short Circuit Rating		
Soft Starter Model Number	Maximum Non-Time-Delay Trip Rating *	
	Fuse * – Class J or T (600V rated)	Circuit Breaker * (600V rated)
SR22-05	15A	N/A
SR22-07	15A	
SR22-09	30A	
SR22-12	40A	
SR22-16	50A	80A
SR22-22	80A	
SR22-30	100A	100A
SR22-36	125A	125A
SR22-40	150A	150A

* Maximum trip ratings are for non-time-delay overcurrent protection devices.
 * Motor branch circuit protection must be based on MOTOR Full Load Current, and must comply with applicable local electrical codes. The 2008 NEC section 430.52 recommends a maximum of 175% (up to 225% absolute maximum) of motor FLC for time-delay fuses. (Class CC time-delay fuses are permitted up to the non-time-delay fuse maximum rating.)

Stellar® SR22 Series Compact Soft Starters

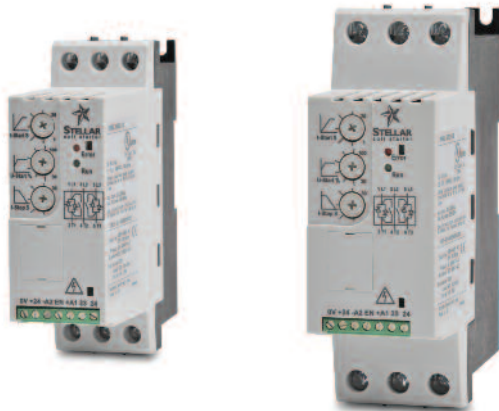

45mm Stellar Compact Soft Starter

55mm Stellar Compact Soft Starter



Cooling Fan for 45mm Soft Starters



Cooling Fan for 55mm Soft Starters

SR22 Dimensions

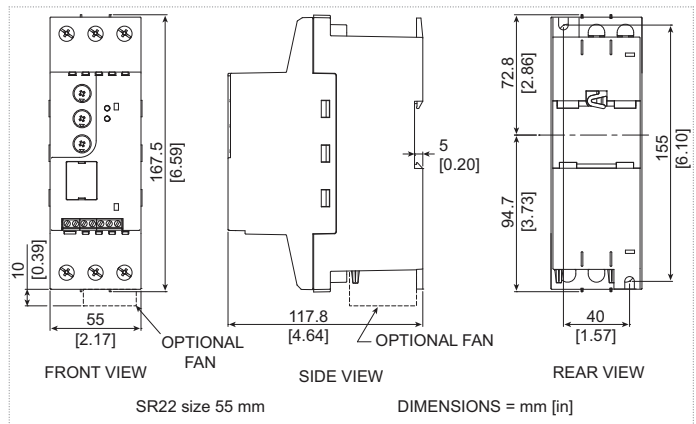
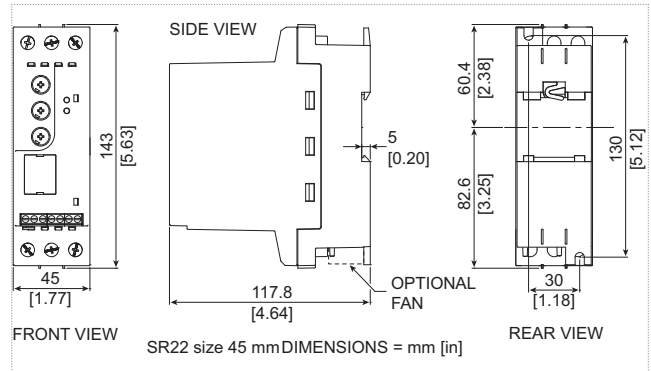

SR22 Start/Stop Timing Diagram

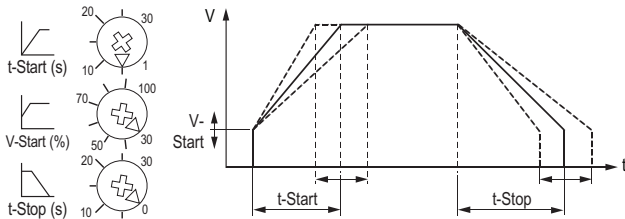

SR22 – PLC I/O Compatibility

SR22 Wiring Diagram

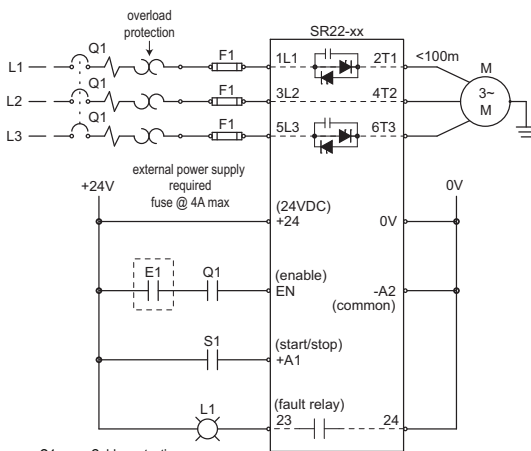

- Q1 = Cable protection
- F1 = Optional semiconductor fuse for Type 1 Coordination (in addition to Q1)
- A1-A2 = Start/Stop
- External Control Circuit Elements
- E1 = Optional switch to allow trip reset without opening main breaker Q1
- Q1 = Auxiliary contact of main breaker Q1
- S1 = Start/Stop control switch
- L1 = Indicator: ON = Ready; OFF = Fault

SR22 – PLC & I/O Compatibility		
Product Line	Module Type	Module Numbers
CLICK	PLC	C0-00AR-D, C0-00DD2-D, C0-00DR-D, C0-02DD2-D, C0-02DR-D
	DC Output	C0-08TD2, C0-16TD2
	Relay Output	C0-04TRS, C0-08TR
Productivity3000	DC Output	P3-08ND3S, P3-16ND3, P3-32ND3, P3-64ND3
	Relay Output	P3-08TAS, P3-16TA, P3-08TRS, P3-16TR, P3-08TRS-1
DL05	PLC	D0-05AR, D0-05DR, D0-05DR-D
DL06	PLC	D0-06AR, D0-06DD2, D0-06DD2-D, D0-06DR, D0-06DR-D
DL05/DL06	DC I/O	D0-07CDR
	DC Output	D0-10TD2, D0-16TD2, D0-08TR, F0-04TRS
DL105	PLC	F1-130-DR, F1-130-DR-D
DL205	DC I/O	D2-08CDR
	DC Output	D2-08TD2, D2-16TD2-2, D2-32TD2, F2-16TD2P
	Relay Output	D2-04TRS, D2-08TR, D2-12TR, F2-08TR, F2-08TRS
DL305	DC Output	D3-08TD2, D3-16TD2
	Relay Output	D3-08TR, D3-16TR
DL405	DC Output	D4-16TD2, D4-32TD2
	Relay Output	D4-08TR, D4-16TR, F4-08TRS-1, F4-08TRS-2
Terminator I/O	DC Output	T1K-08TD2-1, T1K-16TD2-1
	Relay Output	T1K-08TR, T1K-08TRS, T1K-16TR

Stellar® SR33 Series Basic Soft Starters

Overview

SR33 semi-conductor soft starters provide many advantages when used instead of electro-mechanical contactors to control 3-phase AC induction motors. The SR33 soft starters use thyristors for controlled reduced voltage motor starting and stopping, then switch to internal contacts for efficient running at rated speed.

Designed to fit in place of existing wye-delta starters.

Features

- 22-482A @ 208-230/460 VAC
- 24 VDC or 115 VAC I/O
- 24 VDC control power required
- Two-phase control
- Internal bypass contacts for Run
- Easily and separately adjustable motor start voltage and start and stop times
- Suitable for a wide variety of motor loads
- Can replace wye/delta starters
- Fault indication of 4 or 7 fault types, depending upon model: SCR or Power Supply, Overheat, Control Power Supply, Bypass Relay Failure, Shearpin, Overload, Overcurrent
- IP20 (SR33-22 to SR33-97)
IP00 (SR33-132 to SR33-482)
panel mount
- Two-year warranty

Advantages

Mechanical Advantages

- Smooth acceleration; reduced mechanical shock and starting stress
- Extend lifespan of mechanical drive train components
- Fluid couplings and some clutches can be eliminated

Electrical Advantages

- Reduces starting currents and spikes
- Reduces high transient currents
- More motors or larger motors can be started from lower-capacity power sources
- Allows motors to be started more frequently
- Internal mechanical contacts open and close under reduced current, increasing lifespan and reliability

Economic Advantages

- Lower overall costs for new installations
- Reduced maintenance and replacement of mechanical drive train components
- Reduced starting current reduces electrical power costs

Standards & Approvals

- CE
- REACH
- RoHS
- UL listed* (E333109)
* (soft starters SR33-350 to SR33-482 are not UL listed or recognized)

Accessories

- Heat-shrink insulation kit SR33-HS1 (required for soft starters SR33-132 to SR33-280 used in UL applications)

Applications

- General purpose applications where traditional across-the-line starting or wye-delta starting would typically be appropriate.



SR33-22 to SR33-55



SR33-66 to SR33-97



SR33-132 to SR33-195



SR33-241 to SR33-482

Stellar[®] SR33 Series Basic Soft Starters

SR33 Soft Starter Technical Specifications

SR33 Series Basic Soft Starters – 22A-482A * – Model-Specific Specifications and Features							
Model	SR33-22	SR33-29	SR33-41	SR33-55	SR33-66	SR33-80	SR33-97
Price	<--->	<--->	<--->	<--->	<--->	<--->	<--->
* Rated Current [trip class 5] (A)	22	29	41	55	66	80	97
* Motor Rating	Refer to selection table. Starters must be sized according to HP and starting class .						
** Short Circuit Current Rating (Type 1)	5kA for SR33-22 to SR33-55; 10kA for SR33-66 to SR33-195; 18kA for SR33-241 to SR33-482						
Control Power Supply Required Output Capacity	approx 4VA						
Overload Trip	n/a						
Terminals: Power / Ground	wire clamp terminals / M6				wire clamp terminals / M8		
Design Standards	UL508 Industrial Control Equipment; EN/IEC 60947-4-2 "AC Semiconductor Motor Controllers and Starters"						
Environmental Rating	IP20						
Product Weight (kg [lb])	2.3 [5.1]				3.5 [7.75]		

Model	SR33-132	SR33-160	SR33-195	SR33-241	SR33-280	SR33-350	SR33-430	SR33-482
Price	<--->	<--->	<--->	<--->	<--->	<--->	<--->	<--->
* Rated Current [class 10(B) trip] (A)	132	160	195	241	280	350	430	482
* Motor Rating	Refer to selection table. Starters must be sized according to HP and starting class .							
** Short Circuit Current Rating (type 1)	5kA for SR33-22 to SR33-55; 10kA for SR33-66 to SR33-195; 18kA for SR33-241 to SR33-482							
Control Power Supply Required Output Capacity	approx 12VA, capable of 4A for 250ms							
Overload Trip	n/a			Single-phase sensing; Non-adjustable; (refer to O/L trip curve)				
Terminals: Power / Ground	external busbars / M8				external busbars / M10			
Design Standards	UL508 Industrial Control Equipment					n/a		
	EN/IEC 60947-4-2 "AC Semiconductor Motor Controllers and Starters"							
Environmental Rating	IP00							
Product Weight (kg [lb])	4.3 [9.5]			9.7 [21.4]		13.5 [29.8]		
* Refer to Selection Table for deratings by application and overload trip class.				** When protected by recommended semiconductor fuse.				

SR33 Series Basic Soft Starters – General Specifications and Features	
Models	All Models (SR33 -22, -29, -41, -55, -66, -80, -97, -132, -160, -195, -241, -280, -350, -430, -482)
Rated Operational Voltage / Frequency	230–460VAC rms 3-phase (-15% +10%) / 50–60Hz +/- 2Hz; Form Designation = Form 1
Impulse Withstand Voltage	4kV
Insulation Voltage Rating	500V (IEC standard insulation rating. Actual testing proves insulation withstand capacity beyond 460V+10%)
Control Power Supply General Requirements	24VDC supplied externally to terminals X1-X2; Residual Ripple: 100mV; Spikes/Switching Peaks: 240mV; Turn On/Off Response: No overshoot of V _{out} ; Output voltage must be clamped to < 30V
Control Input (Start/Stop)	24V DC/110V AC galvanically isolated terminals A1-A2 (1mA @ 24V DC; 3mA @ 110V AC; not suitable for use with PLC triac output)
Control Relay Outputs	230VAC, 3A, resistive; 230VAC, 1A, AC15; Run – 13/14; Ready – 23/24
Start Time Setting Range	0 to 30 seconds
Start Voltage Setting Range	30 to 100 percent
Stop Time Setting Range	0 to 30 seconds
Start Duty	S1 per IEC 34-1 & VDE0530 Part 1. 3 x FLC for 5 seconds @ standard rating (Class5, 40°C [104°F]).
Starts / Hour	10 starts per hour, or 5 starts + 5 soft stops per hour
Index Rating	Class 5; AC53b: 3-5: 355; internally bypassed (10 starts/hr)
Indication	Multi function LED on front panel
Ambient Operating Temperature	0 to 40 °C [32 to 104 °F] – Above 40°C [104 °F] derate linearly by 2% of unit FLC per °C to a max derate of 40% at 60°C [140 °F]. (Derating not UL. Refer to separate UL Ratings and Protection Requirements)
Transportation & Storage Temperature	-25 to 60 °C [-13 to 140 °F]
Humidity	max 85% non-condensing, not exceeding 50% at 40°C [104°F]
Altitude	1000m [3281 ft]. Above 1000m de-rate linearly by 1% of unit FLC per 100m to a max altitude of 2000m [6562 ft].
Pollution Degree	For use in a Pollution Degree 2 environment; No corrosive gases

Stellar® SR33 Series Basic Soft Starters

SR33 Soft Starter Accessory

SR33 Series Basic Soft Starters – Accessory			
Part Number	Name	Price	Description
SR33-HS1	Insulation Kit	<--->	Heat-shrink insulation required for soft starters SR33-132 to SR33-280 used in UL applications. Can also be used with SR33-350 to SR33-482.

SR33 Soft Starter Index Ratings

SR33 Index Ratings – AC-53b (Bypassed Operation) *			
Trip Class	X-Tx; OFF-time	I _e (A)	Model #
5	3-5; 355 (10)	22 to 482	SR33-22 to SR33-482
	3.5-12; 708 (5)	29 to 241	SR33-29 to SR33-241
10B	3.5-12; 1188 (3)	280 to 482	SR33-280 to SR33-482
	3-23; 697 (5)	29 to 280	SR33-29 to SR33-280
10	3-23; 1177 (3)	350 to 482	SR33-350 to SR33-482
	4-19; 701 (5)	29 to 350	SR33-29 to SR33-350
20	4-19; 1181 (3)	430 to 482	SR33-430 to SR33-482
	4-29; 691 (5)	41 to 430	SR33-41 to SR33-430
30	4-29; 1171 (3)	482	SR33-482

* Index rating AC-53b is specified by IEC standard # 60947-4-2

Index Rating Example - Bypassed Operation (AC-53b Utilization Category per IEC 60947-4-2)

AC-53b = controller semiconductors provide squirrel-cage motor Start control only; bypassed for Run and Stop.

IEC Index Ratings are comprised of Rated Operational Current (I_e), Utilization Category, Overload Current Profile (X-Tx), OFF-time.

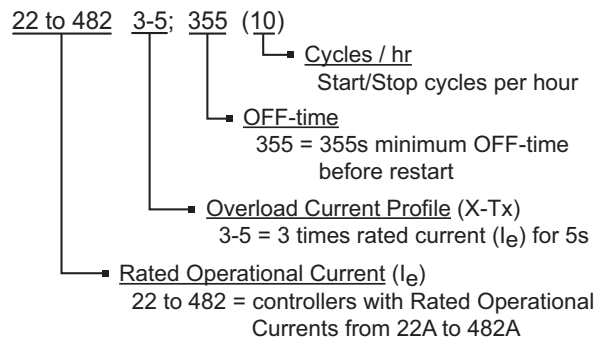

Stellar® SR33 Series Basic Soft Starters

SR33 Soft Starter Selection

SR33 Sizing Guide

The SR33 is designed for general purpose applications and where a traditional Wye/Delta is currently used (or considered appropriate). Generally the motor will start off-load, and the time to accelerate to full speed will be in the range of a few seconds.

The standard SR33 range is suitable for the majority of applications, and conforms to Trip Class 5, which means it is capable of withstanding three times Full Load Current for 5-second starts. However, there are instances where a different start profile is required. To satisfy these applications, the SR33 has four other ratings; Class 10B, Class 10, Class 20, and Class 30. These ratings correspond to IEC thermal/electronic overload trip classes, and the SR33 must be used with an overload protection device that has a rating corresponding to the Trip Class selected.

When using the selection tables to select the most appropriate SR33 model, please note the following:

- The SR33 is not suitable for very high inertia loads, such as centrifuges or loaded crushers, with starts > 30 seconds.
- Do not use the Class 5 rating when there is a possibility of the motor starting with a significant load.
- 2-pole motors may take longer to start, so use a minimum of Trip Class 10B.

SR33 Soft Starters – O/L Trip Class ①			
Application	Trip Class	Start Time (s)	Notes
Standard	5	5	Suitable for Wye/Delta applications with < 5s start time, motor starts off-load
Heavy	20	12–19	Suitable for Wye/Delta with applications > 12s start time
High Torque	20	12	Requires more starting torque than a Wye/Delta
Centrifugal Pump	10B	10–15	Generally easy to start when pumping water
Positive Displacement Pump (unloaded)	10	5–10	Can be difficult to start
Off-Load Conveyor	5	5	Unloaded at start
Heavy conveyor	20	5–10	Loaded at start
Low-Inertia Fan	10	10–20	Generally fans less than or equal to 45kW (60hp)
High-Inertia Fan	30	30	Generally fans greater than or equal to 45kW (60hp)
Off-Load Compressor	5	5–10	Special circuits ensure motor starts off-load
Loaded Compressor	20	10–15	Some compressor systems can be difficult to start
Off-Load Mixer	5	5	No material in basin; off-load
Heavy Mixer	20	10–15	Material in basin

SR33 Selection Steps

- ① Determine the required trip class based on the motor load and required start time.
- ② Select the applicable SR33 part number based on the required Trip Class and motor HP.

SR33 SELECTION – Selection Table ②							
I (A)	Motor		Soft Starter Application Trip Class				
	HP @ 230V	HP @ 460V	Class 5	Class 10B	Class 10	Class 20	Class 30
			10 starts/hr	5 starts/hr			
22	7.5	15	SR33-22	SR33-29	SR33-29	SR33-29	SR33-41
29	10	20	SR33-29	SR33-41	SR33-41	SR33-41	SR33-55
41	10	30	SR33-41	SR33-55	SR33-55	SR33-66	SR33-97
55	20	40	SR33-55	SR33-66	SR33-66	SR33-97	SR33-132
66	20	50	SR33-66	SR33-80	SR33-80	SR33-132	SR33-132
80	30	60	SR33-80	SR33-132	SR33-132	SR33-132	SR33-160
97	30	75	SR33-97	SR33-132	SR33-132	SR33-160	SR33-195
132	50	100	SR33-132	SR33-195	SR33-195	SR33-241	SR33-280
160	60	125	SR33-160	SR33-241	SR33-241	SR33-280	SR33-350
195	75	150	SR33-195	SR33-241	SR33-280	SR33-350	SR33-430
–	–	–	–	3 starts/hr			
241	75	200	SR33-241	SR33-280	SR33-350	SR33-430	SR33-482
280	100	200	SR33-280	SR33-350	SR33-430	SR33-482	–
350	125	250	SR33-350	SR33-482	SR33-482	–	–
430	150	350	SR33-430	–	–	–	–
482	200	400	SR33-482	–	–	–	–



FOR MOTOR OVERLOAD PROTECTION, THE SR33 MUST BE USED WITH A SEPARATE CUSTOMER-SUPPLIED OVERLOAD PROTECTION DEVICE THAT HAS A RATING CORRESPONDING TO THE APPLICABLE TRIP CLASS.

Stellar® SR33 Series Basic Soft Starters

SR33 Soft Starter Circuit Protection

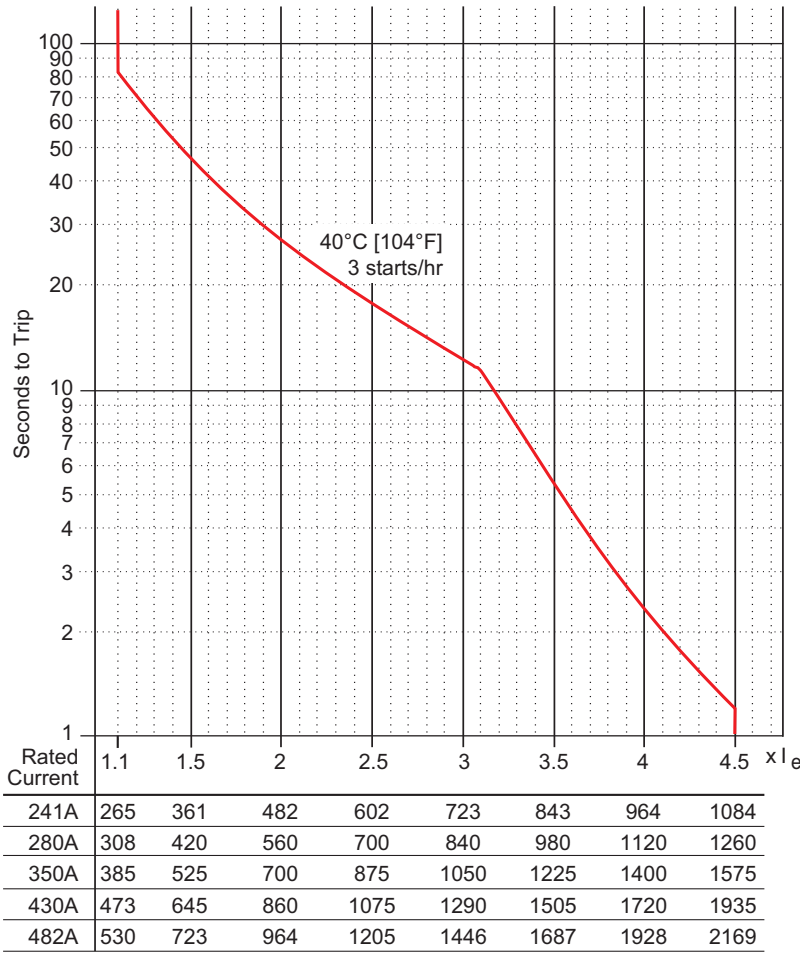

Trip Level Current (Amps)

The SR33 can be used at ratings other than those stated. Use the above trip curves to determine the required unit for the duty.

As an example, the SR33-280 will run a 200hp motor (280 Amp) at the maximum continuous running current and will allow an overload of 3 x 280 Amp (840A) for 12 seconds, 3 times per hour. The unit would also allow a 3.5 x overload (980A) for approximately 5½ seconds, 3 times per hour.

Following an overload trip, subsequent restarts can be restricted due to a cooling time. The severity of overload determines the cooling time, which has a maximum value of 10 minutes.

THE SOFT STARTER OVERLOAD TRIP CURVE SHOWN ON THIS PAGE APPLIES ONLY TO MODEL NUMBERS SR33-241 THROUGH SR33-482, AND IT PROVIDES PROTECTION ONLY FOR THE SOFT STARTER. FOR MOTOR OVERLOAD PROTECTION, A SEPARATE CUSTOMER-SUPPLIED OVERLOAD PROTECTION DEVICE MUST BE PROVIDED.



UL Short Circuit Protection **			
SR33 Model Number *	Short Circuit Rating	Class J High-Speed or RK5 Time-Delay Current-Limiting Fuse *** Rated 600VAC	Circuit Breaker Rated 600VAC
SR33-22	5kA	35A	—
SR33-29	5kA	45A	—
SR33-41	5kA	60A	—
SR33-55	5kA	80A	—
SR33-66	10kA	125A	—
SR33-80	10kA	175A	—
SR33-97	10kA	200A	—
SR33-132	10kA	250A	350A
SR33-160	10kA	350A	450A
SR33-195	10kA	400A	500A
SR33-241	18kA	450A	—
SR33-280	18kA	450A	—

* Soft starters SR33-350 to SR33-482 are NOT UL listed or recognized.
 ** Suitable for use on a circuit capable of delivering not more than the RMS symmetrical Amperes as indicated at 480VAC maximum, when protected by fuses or inverse-time circuit breakers with rated maximum Amperes as indicated.
 *** Fuse comparable to Edison type JHL (class J) or ECSR (class RK5).

RECOMMENDED FUSING for IEC Type 1 Coordination Short Circuit Protection				
SR33 Model Number	Rated Short Circuit Current	SIBA Semiconductor Fuse	Class J High-Speed or RK5 Time-Delay Current-Limiting Fuse* Rated 600VAC	
			Amp	Edison JHL Part #
SR33-22	5kA	2018920.50A	35A	JHL35
SR33-29		2018920.100A	45A	JHL45
SR33-41			60A	JHL60
SR33-55	10kA	2018920.125A	80A	JHL80
SR33-66			125A	JHL125
SR33-80		2061032.200A	175A	JHL175
SR33-97			200A	JHL200
SR33-132			250A	JHL250
SR33-160	2061032.400A	350A	JHL350	
SR33-195		400A	JHL400	
SR33-241	18kA	2062032.630	450A	JHL450
SR33-280				
SR33-350		2063032.1000	—	
SR33-430				
SR33-482				

* Fuse comparable to Edison type JHL (class J) or ECSR (class RK5).

Stellar® SR33 Series Basic Soft Starters

UL Maximum Surrounding Air Temperatures									
SR33 Model Number *	Maximum 40°C [104°F]		Maximum 50°C [122°F]		SR33 Model Number *	Maximum 40°C [104°F]		Maximum 50°C [122°F]	
	I (A)	HP @ 480V	I (A)	HP @ 480V		I (A)	HP @ 480V	I (A)	HP @ 480V
SR33-22	22	15	20	10	SR33-97	97	75	78	60
SR33-29	29	20	27	20	SR33-132	132	100	119	75
SR33-41	41	30	37	25	SR33-160	160	125	144	100
SR33-55	55	40	45	30	SR33-195	195	150	176	125
SR33-66	66	50	60	40	SR33-241	241	200	193	150
SR33-80	80	60	72	50	SR33-280	280	200	224	150

* Soft starters SR33-350 to SR33-482 are NOT UL listed or recognized.

SR33 Soft Starter Timing Diagram

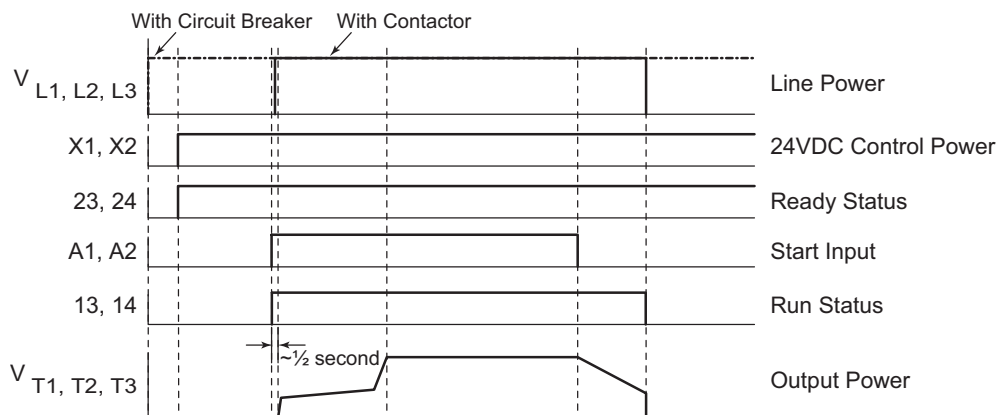

SR33 Soft Starter Standard Wiring Diagram

For complete wiring instructions, refer to the "SR33 Digital Soft Starters Quick-start Guide: Installation and Operation" included with the SR33 soft starter and available online at www.AutomationDirect.com.

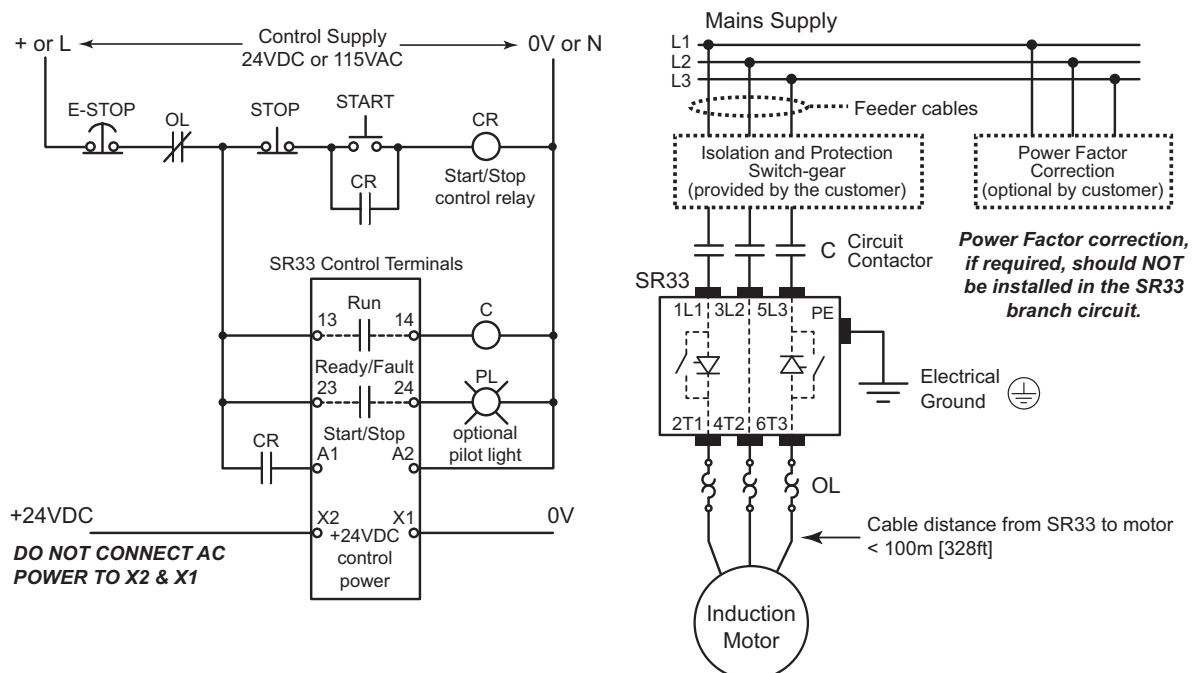

Stellar® SR33 Series Basic Soft Starters

SR33 Soft Starter Dimensions (mm [in])

SR33-22 to SR33-55 – 15hp to 40hp @ 460V

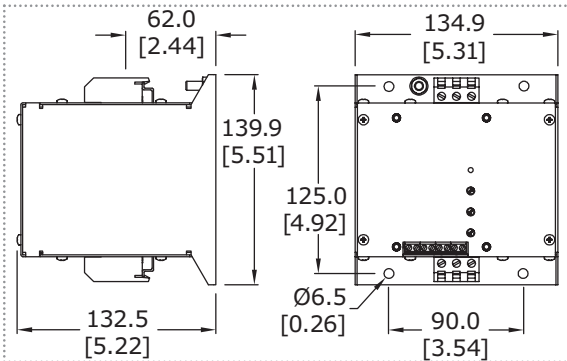

SR33-66 to SR33-97 – 50hp to 75hp @ 460V

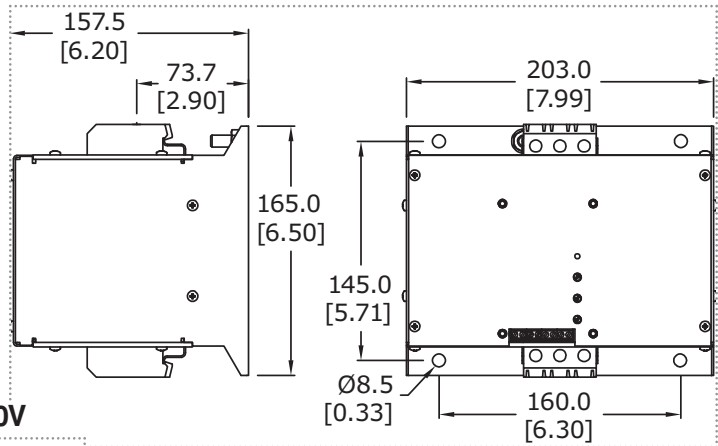

SR33-132 to SR33-195 – 100hp to 150hp @ 460V

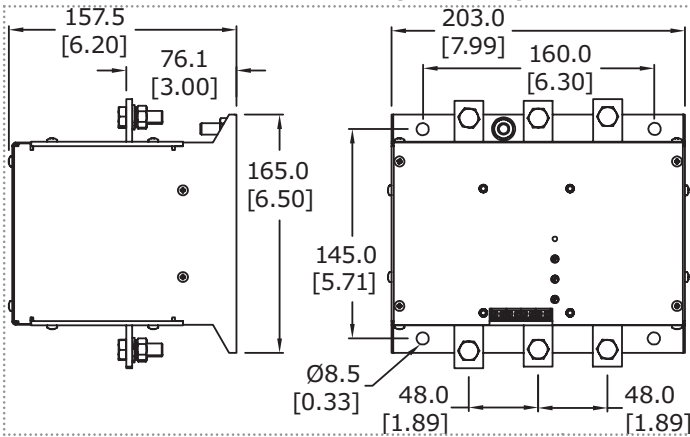

SR33-241 to SR33-482 – 200hp to 400hp @ 460V

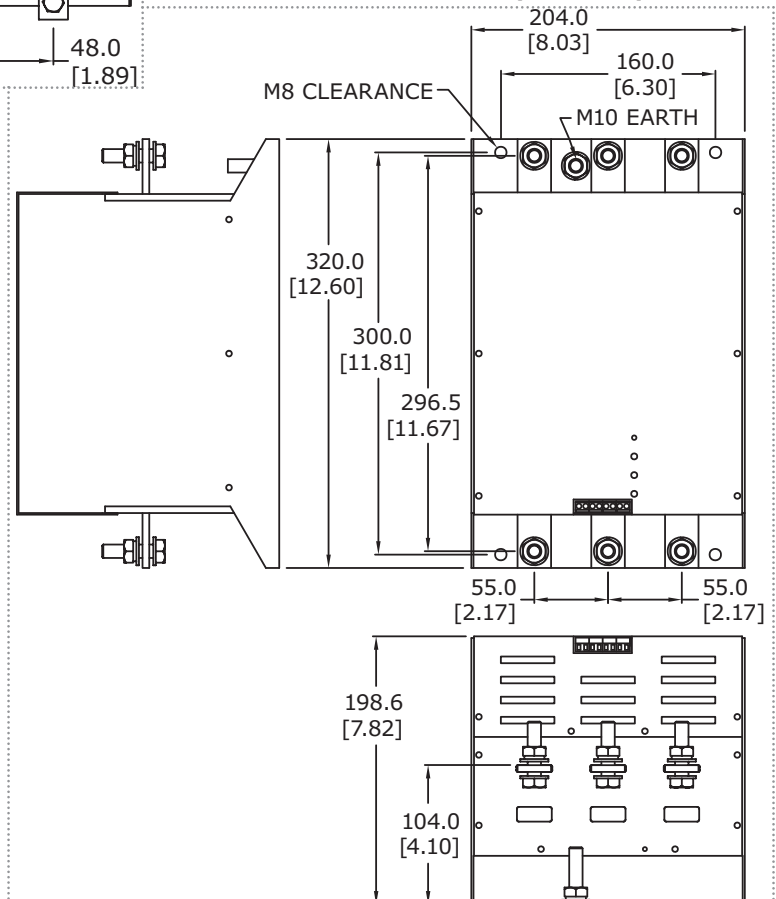

Stellar® SR44 Full-Featured Soft Starters

Overview

SR44 full-featured solid-state Soft Starters provide many advantages when used instead of electromechanical contactors to control 3-phase AC induction motors. The SR44 Soft Starters are fully digital, and use thyristors in all three motor phases for controlled reduced voltage motor starting and stopping. SR44s have an Automatic Application Setup that fully configures the starter for a specific application with one entry. SR44s also have a built-in "Optimizing" mode that reduces energy costs when used on lightly loaded and oversized motors, and external bypass capability for efficient running at rated speed.

Features

- 9–370A @ 230–460VAC
- 115 or 230 VAC selectable control voltage
- Full three-phase motor control
- Fully programmable
- Easily and separately adjustable motor start and stop times
- External bypass capability for run
- Advanced energy-saving Optimizing Mode improves motor efficiency and power factor while delivering demanded torque at low rpm (as compared to across-the-line control); and prolongs motor life
- Can be connected 'in-the-delta', allowing use of a smaller Soft Starter
- Can be used for motor reversing (with external contactors)
- Suitable for a wide variety of motor loads
- Keypad: 6 buttons with 2-line, 32-character display
- Can be used with local or remote control
- Optional Modbus or Remote Keypad control
- Programmable I/O for remote control: 1 digital input; 2 relay outputs
- Fault record history of last 5 trips
- IP20, panel mount
- Two-year warranty

SR44-RS485 Communication Card

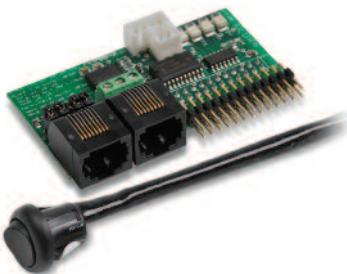

Advantages

Mechanical Advantages

- Smooth acceleration; reduced mechanical shock and starting stress
- Extend lifespan of mechanical drive train components
- Fluid couplings and some clutches can be eliminated

Electrical Advantages

- Reduced starting currents and spikes
- More motors or larger motors can be started from lower-capacity power sources
- Allows motors to be started more frequently

Economic Advantages

- Lower overall costs for new installations
- Reduced maintenance and replacement of mechanical drive train components
- Reduced starting current lowers demand charges
- Energy Optimizing mode reduces electrical power costs
- Automatic Application setup feature speeds installation by configuring the SR44 for a specific application with one setting.

Standards & Approvals

- CE
- REACH
- RoHS
- UL listed* (E333109)
* Options SR44-KPD & SR44-RS485 are not UL approved

Optional accessories

- Communication/Modbus card SR44-RS485
- Remote keypad SR44-KPD*
*(requires SR44-RS485)

Applications

- General purpose applications where traditional across-the-line starting or wye-delta starting would typically be appropriate.

SR44-KPD Remote Keypad



SR44 Size 2 Soft Starter



SR44 Size 1 Soft Starter



Stellar® SR44 Full-Featured Soft Starters

SR44 Soft Starter Technical Specifications

SR44 Series Full-Featured Soft Starters – Size 1 – 9A-146A*										
Model	SR44-9	SR44-16	SR44-23	SR44-30	SR44-44	SR44-59	SR44-72	SR44-85	SR44-105	SR44-146
Price	<--->	<--->	<--->	<--->	<--->	<--->	<--->	<--->	<--->	<--->
* Rated Current [class 10(B) trip] (A)	9	16	23	30	44	59	72	85	105	146
Rated Operational Voltage	230–460 VAC (-15% +10%) @ 50–60 Hz (±2Hz); 3 phase; (usable on 208V systems down to 196V)									
* Motor Rating	Refer to selection table. Starters must be sized according to HP and starting class .									
Impulse Withstand Voltage	4kV									
Insulation Voltage Rating	690 VAC									
Short Circuit Current Rating (type 1)	5 kA					10 kA				
Control Power Consumption	8VA			10 VA			12 VA			
Control Voltage Range	115 VAC (-15% +10%) or 230 VAC (-15% +10%); 1 phase									
Control Fuse (external)	125 mA @ 115V; 63 mA @ 230V				200 mA @ 115V; 100 mA @ 230V					
Control Input	12/24 VDC or 115/230 VAC									
Control Relay Outputs	(2) SPDT; 3A @ 230 VAC; AC11 (electro-magnet control)									
Start Time Setting Range	1–255 seconds									
Start Voltage Setting Range	10–60% [% of main power voltage]									
Stop Time Setting Range	0–255 seconds									
Ambient Operating Temperature	0–40 °C [32–104 °F] – Above 40 °C [104 °F] derate linearly by 2% of unit FLC per °C to a max derate of 40% @ 60 °C [140 °F]									
Transportation & Storage Temperature	-25–60 °C [-13–140 °F] continuous ; -25–75 °C [-13–167 °F] NOT exceeding 24 hours									
Humidity	max 85% non-condensing; not exceeding 50% @ 40 °C [104 °F]									
Altitude	1000m [3281 ft]; Above 1000m [3281 ft] derate linearly by 1% of unit FLC per 100m to MAX 2000m [6562 ft]									
Environmental Rating	IP20									
Shipping Weight	16 lb [7.3 kg]					18 lb [8.2 kg]				
Dimensions (HxWxD)	415 x 222 x 195 mm [16.3 x 8.74 x 7.68 in]									
* Refer to Selection Table for deratings by application and overload trip class.										

SR44 Series Full-Featured Soft Starters – Size 2 – 174A-370A*					
Model	SR44-174	SR44-202	SR44-242	SR44-300	SR44-370
Price	<--->	<--->	<--->	<--->	<--->
* Rated Current [class 5 starting] (A)	174	202	242	300	370
Rated Operational Voltage	230–460 VAC (-15% +10%) @ 50–60 Hz (±2Hz); 3 phase; (usable on 208V systems down to 196V)				
* Motor Rating	Refer to selection table. Starters must be sized according to HP and starting class .				
Impulse Withstand Voltage	4kV				
Insulation Voltage Rating	690VAC				
Short Circuit Current Rating (type 1)	10 kA			18 kA	
Control Power Consumption	18 VA				
Control Voltage Range	115 VAC (-15% +10%) or 230 VAC (-15% +10%); 1 phase				
Control Fuse (external)	200 mA @ 115V; 100 mA @ 230V				
Control Input	12/24 VDC or 115/230 VAC				
Control Relay Outputs	(2) SPDT; 3A @ 230 VAC; AC11 (electro-magnet control)				
Start Time Setting Range	1–255 seconds				
Start Voltage Setting Range	10–60% [% of main power voltage]				
Stop Time Setting Range	0–255 seconds				
Ambient Operating Temperature	0–40 °C [32–104 °F] – Above 40 °C [104 °F] derate linearly by 2% of unit FLC per °C to a MAX derate of 40% @ 60 °C [140 °F]				
Transportation & Storage Temperature	-25–60 °C [-13–140 °F] continuous ; -25–75 °C [-13–167 °F] NOT exceeding 24 hours				
Humidity	max 85% non-condensing; not exceeding 50% @ 40 °C [104 °F]				
Altitude	1000m [3281 ft]; Above 1000m [3281 ft] derate linearly by 1% of unit FLC per 100m to MAX 2000m [6562 ft]				
Environmental Rating	IP20				
Shipping Weight	40 lb [18 kg]			50 lb [23 kg]	
Dimensions (HxWxD)	520 x 340 x 265 mm [20.5 x 13.4 x 10.4 in]				
* Refer to Selection Table for deratings by application and overload trip class.					

Stellar® SR44 Full-Featured Soft Starters

SR44 Soft Starter Optional Accessories

SR44 Series Full-Featured Soft Starters – Optional Accessories			
Part Number	Name	Price	Description
SR44-KPD	Remote Keypad	<--->	Can be used to remotely monitor and/or program SR44 Soft Starters. Rated NEMA 4/4X. No external power wiring required. Works with all SR44 Soft Starters. Includes: Keypad, Cable (3m). NOTE: Optional SR44-RS485 communication card must be installed to use the SR44-KPD remote keypad. SR44-KPD can control multiple SR44 Soft Starters, but only one at a time.
SR44-RS485*	Communication Card *	<--->	Can be used to establish RS-485 communication between an SR44 Soft Starter and most Modbus masters. A PLC or PC is required to demux the data returned from the SR44. (See the User Manual for details and PLC sample ladder programs.) Plugs directly onto the control board of an SR44. No external power needed. Has both RJ45 connections and screw-type terminal strip connections; can be used with CAT5 RJ45-terminated Ethernet cable, or with twisted pair shielded wiring. Max # of networked SR44s: 8. Max network length: 25m [82 ft] for RJ45 connections; 1200m [3937 ft] for RS-485 screw-terminal connections. Can be used with an SR44-KPD to create an internal RS-485 network between SR44 Soft Starters (one remote keypad to control multiple SR44s, one at a time). Works with all SR44 Soft Starters. Includes: Circuit card, Remote/Local selector switch.

Communication cables for use with the SR44-RS485 communication card are available in our ZIPLink Wiring Solutions section:
SR44-485HD15-CBL-2 for connection to certain PLCs; SR44-485RJ45-CBL-2 for connection to certain RS485 networks

SR44 Index Ratings (per IEC 60947-4-2)

SR44 Index Ratings *			
Model #	I_e (A)	Standard Operation AC-53a; X-Tx; F-S	Bypassed Operation AC-53b; X-Tx; OFF-time
SR44-9 to SR44-105	9 to 105	AC-53a: 5-4; 99-10 AC-53a: 3-35; 99-10	AC-53b: 5-4; 120 AC-53b: 3-35; 120
SR44-146 to SR44-202	146 to 202	AC-53a: 4-6; 99-10 AC-53a: 3-35; 99-10	AC-53b: 4-6; 120 AC-53b: 3-35; 120
SR44-242 to SR44-370	242 to 370	AC-53a: 4-6; 60-3 AC-53a: 3-35; 60-3	AC-53b: 4-6; 420 AC-53b: 3-35; 420

* Index ratings AC-53a and AC-53b are specified by IEC standard # 60947-4-2

In line with the stated IEC starting duties, starters of 242 Amps and above have an enforced off period of seven minutes set as standard. During this period the display indicates "Stopped. Cooling", and the starter will not respond to a start signal.

IEC Index Ratings are comprised of Rated Operational Current (I_e), Utilization Category, Overload Current Profile (X-Tx), and Duty Cycle (F-S) or OFF-time.

Index Rating Example - Standard Operation (AC-53a Utilization Category per IEC 60947-4-2)

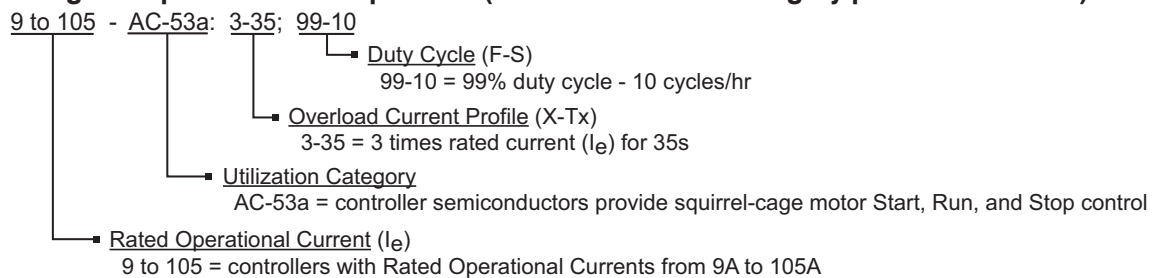

Index Rating Example - Bypassed Operation (AC-53b Utilization Category per IEC 60947-4-2)

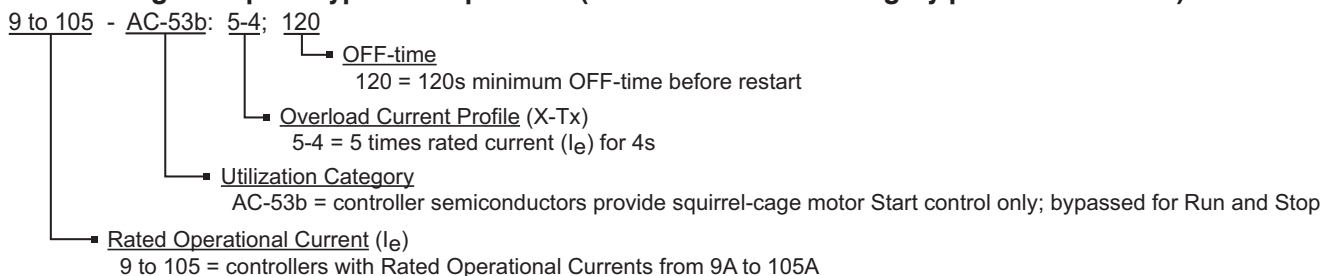

Stellar® SR44 Full-Featured Soft Starters

SR44 Soft Starter Selection

SR44 Soft Starters – O/L Trip Classes ①	
Default	10
Heavy	20
Agitator	10
Air Compressor - Equalized	10B
Air Compressor - Loaded	20
Ball Mill	20
Centrifuge - extended start, needed for sizing	
Chiller	10B
Conveyor - Unloaded	10B
* Conveyor - Loaded	20
Crusher	30
Escalator	10B
* Fan - Low Inertia < 85A	10
* Fan - High Inertia > 85A	30
Feeder - Screw	10
Grinder	20
Hammer Mill	20
Lathe Machine	10B
Mills - Flour, etc.	20
Mixer - Unloaded	10B
Mixer - Loaded	20
Pelletizer	20
Plastic and Textile Machines	10B
Press - Flywheel	20
* Pump - Centrifugal	10B
* Pump - Positive Displacement - Unloaded	10
Rolling Mill	20
Saw - Band	10
Saw - Circular	20
Screen - Vibrating	20
Transformer, Voltage Regulator	10B
Tumbler	10
Wood Chipper	30
* Commonly required applications	

SR44 Soft Starter Selection Steps

- ① Determine the required trip class based on the motor load and required start time.
- ② Select the applicable SR44 part number based on the required Trip Class, motor HP, and connection type.

SR44 Soft Starters – Selection Table ②											
Motor Size								Soft Starter Size			
In-Line Connection				In-Delta Connection **				Application Trip Class			
I (A)	HP @ 208V*	HP @ 230V	HP @ 460V	I (A)	HP @ 208V*	HP @ 230V	HP @ 460V	Class 10B	Class 10	Class 20	Class 30
9	2	3	5	15	2	3	7.5	SR44-9	SR44-16	SR44-23	
16	3	5	10	27	3	5	15	SR44-16	SR44-23	SR44-30	
23	5	7.5	15	39	5	7.5	25	SR44-23	SR44-30	SR44-44	
30	7.5	10	20	51	7.5	10	30	SR44-30	SR44-44	SR44-59	
44	10	15	30	76	10	15	50	SR44-44	SR44-59	SR44-72	
59	15	20	40	102	15	20	60	SR44-59	SR44-72	SR44-85	
72	20	25	50	124	20	25	75	SR44-72	SR44-85	SR44-105	
85	25	30	60	147	25	30	100	SR44-85	SR44-105	SR44-146	
105	30	40	75	181	30	40	125	SR44-105	SR44-146	SR44-174	
146	50	60	100	252	50	60	150	SR44-146	SR44-174	SR44-202	
174	60	75	150	301	60	75	250	SR44-174	SR44-202	SR44-242	
202	60	75	150	349	60	75	300	SR44-202	SR44-242	SR44-300	
242	75	100	200	419	75	100	300	SR44-242	SR44-300	SR44-370	
300	100	100	250	519	100	100	350	SR44-300	SR44-370	n/a	
370	125	150	300	640	125	150	350	SR44-370	n/a	n/a	
<p>* 208V applications are UL listed only as low as 196V.</p> <p>** For In-Delta connections, all six motor wires must be available for connection, and it is critical to exactly follow the In-Delta wiring diagram in the SR44 User Manual or Quick-start Guide. (Nine-lead motors CANNOT be connected in the delta.)</p> <p>The Soft Starter will only sense the Phase Current, which is about 58% of the Line Current.</p>											

Stellar® SR44 Full-Featured Soft Starters

SR44 Dimensions

Size 2: SR44-174 to SR44-370

Size 1: SR44-9 to SR44-146

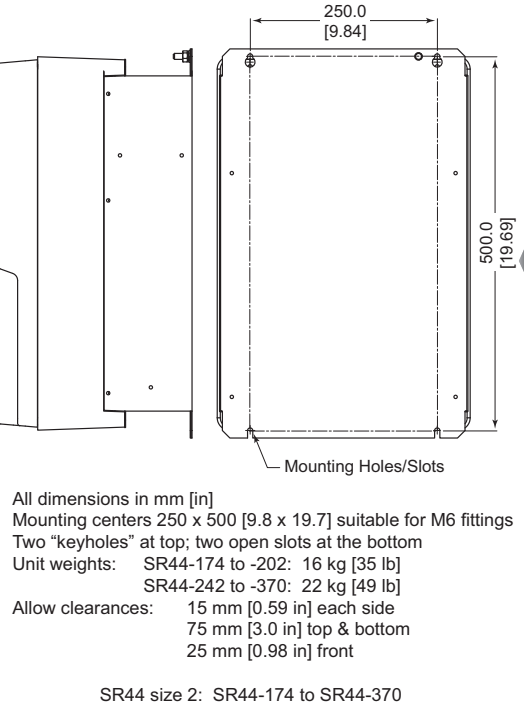
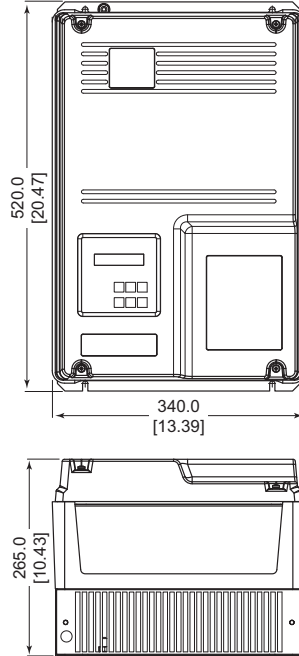
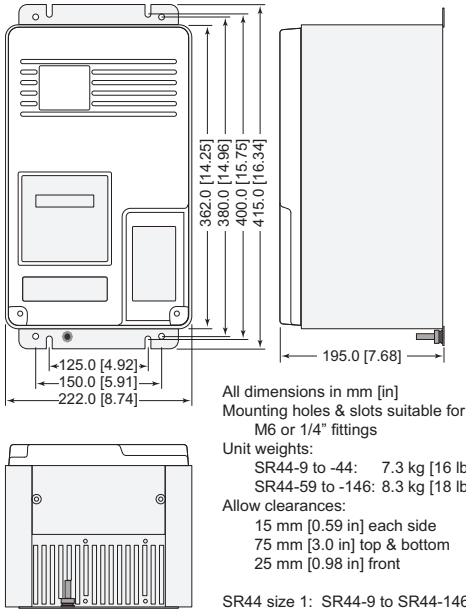

Ventilation for Enclosures

When fitting an SR44 into an electrical enclosure, ventilation must be provided if the heat output of the unit is greater than the enclosure will dissipate.

If the enclosure cannot dissipate enough heat, use the following formula to determine the fan requirement. An allowance has been incorporated into the formula so that the figure for "Q" is the air delivery quoted in the fan supplier's data.

$$Q = (4 \times W_t) / (t_{max} - t_{amb})$$

- Q = required volume of air (cubic meters per hour; m³/h)
 - W_t = total heat produced by the unit and all other heat sources within the enclosure (Watts)
 - t_{max} = maximum permissible temperature within the enclosure (40 °C for a fully rated SR44)
 - t_{amb} = temperature of the air entering the enclosure (°C)
- (If you prefer to work in CFM, substitute °F for °C. Q will then be in CFM, instead of m³/h.)

An approximation of the heat produced by the SR44 (in Watts) can be made by multiplying the Full Load Line Current by three. Exact figures for unit Full Load Current are available in the SR44 user manual.

SR44-KPD Mounting Dimensions

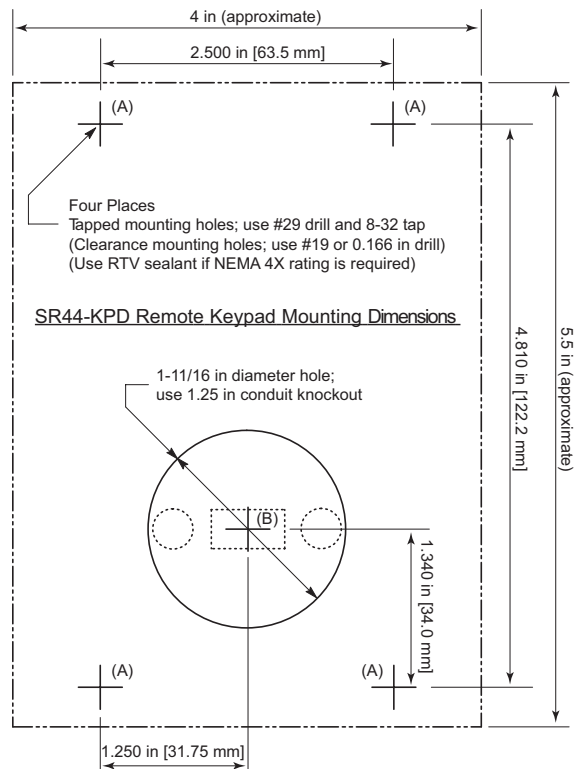

2-Day Delivery!*

Free on orders over \$300



Delivery Service**

- 1-Day Ground Service
- 2-Day Ground Service
- 2-Day Air Service

** for items shipped from Cumming, GA



Get it fast AND free!

Free standard 2-day (transit)* shipping is now available for orders over \$300, within the U.S. and Puerto Rico. We use our choice of carrier and a combination of ground and air services that allow us to reach any U.S. destination within 2 days transit time (or less). (Canadian orders use the same method, but may take longer based on destination.) Orders placed by 6 p.m. EST will ship the same day (with approved company credit or credit card; LTL items require 5 p.m. order cutoff).

Note that the 2-day transit time does not apply for LTL shipping of heavy items or drop-shipped items. (We cannot ship heavy items to Alaska, Hawaii or Puerto Rico. To determine if an item is excluded, check the "Availability" column of the printed price list.)

For orders under \$300, you may request that your order ship via the 2-day (transit) method; shipping charges will be added to invoice.

For complete details on shipping methods and charges, see Terms and Conditions pages TC-4 to 6 of our catalog or on our Web site.

* We do not guarantee delivery times of the carriers. AutomationDirect is not responsible for carrier delays due to weather, mechanical failures or other issues.



1-800-633-0405 www.automationdirect.com