

Appendix Section 36

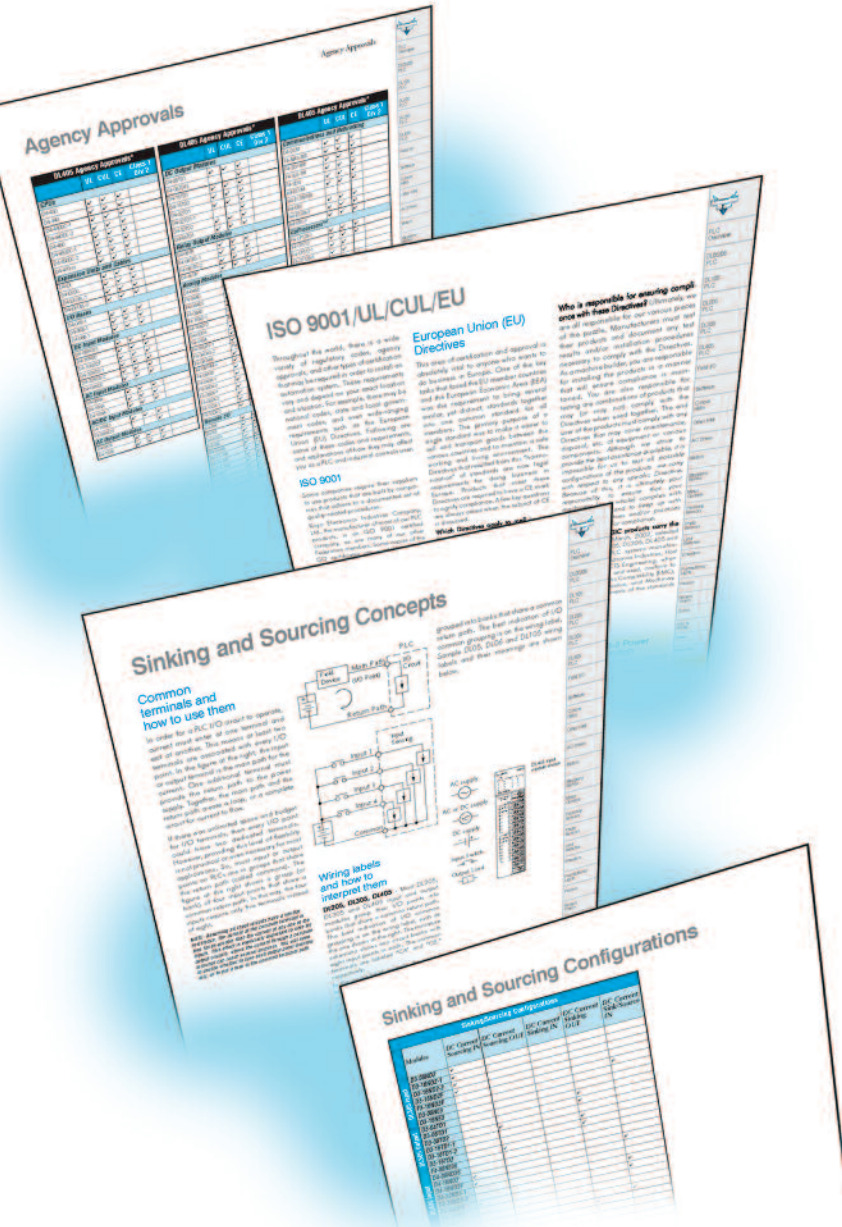

In this interactive PDF you can:

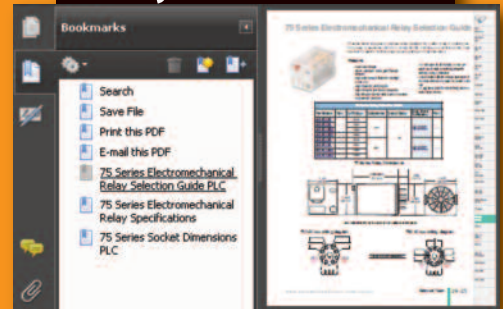

- Use bookmarks to navigate by product category
- Use bookmarks to save, search, print or e-mail the catalog section
- Click on part #s to link directly to our online store for current pricing, specs, stocking information and more

Sinking and Sourcing Concepts

When choosing the type of input or output module for your system (or DL05/DL06/DL105 I/O type), it is very important to have a solid understanding of sinking and sourcing concepts. Use of these terms occurs frequently in discussion of input or output circuits. It is the goal of this section to make these concepts easy to understand, so you can make the right choice the first time when selecting the type of I/O points for your application. This section provides short definitions, followed by general example circuits.

First you will notice that the diagrams on this page are associated with only DC circuits and not AC, because of the reference to (+) and (-) polarities. *Therefore, sinking and sourcing terminology applies only to DC input and output circuits.* Input and output points that are sinking or sourcing can conduct current in one direction only. This means it is possible to connect the external supply and field device to the I/O point, with current trying to flow in the wrong direction, and the circuit will not operate. However, the supply and field device can be connected every time based on an understanding of sourcing and sinking.

The figure below depicts a *sinking* input. To properly connect the external supply, it must be connected so the input provides a path to supply common (-). So, start at the PLC input terminal, follow through the input sensing circuit, exit at the common terminal, and connect the supply (-) to the common terminal. By adding the switch between the supply (+) and the input, the circuit is completed. Current flows in the direction of the arrow when the switch is closed.

By applying the circuit principles to the four possible combinations of input/output sinking/sourcing types, there are four circuits, as shown above. The common terminal is the terminal that serves as the common return path for all I/O points in the bank.

Sinking = provides a path to supply **common (-)**

Sourcing = provides a path to supply **source (+)**

Sinking Input
(IEC: positive logic)

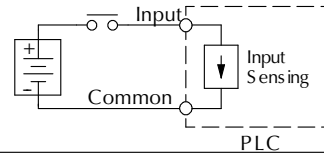

Sinking Output
(IEC: negative logic)

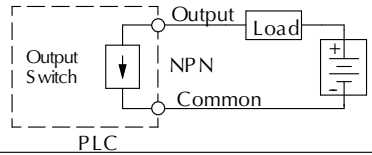

Sourcing Input
(IEC: negative logic)

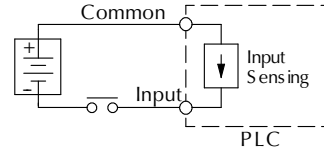

Sourcing Output
(IEC: positive logic)

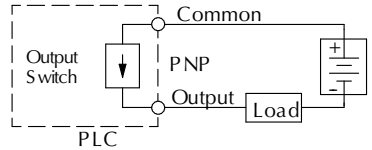

Sink/source I/O circuits combine sinking and sourcing capabilities. This means that the I/O circuitry in the PLC will allow current to flow in either direction, as shown at the right. The common terminal connects to one polarity, and the I/O point connects to the other polarity (through the field device). This provides flexibility in making connections to your field power supply. Please note:

- Wire all I/O points with a shared common as either sinking or sourcing.
- Do not use an AC power supply on a DC sink/source I/O point.

Sink/Source Input
(IEC: pos./neg. logic)

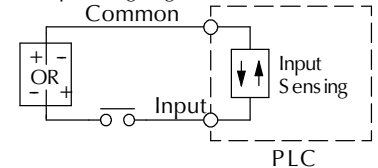

Sink/Source Output
(IEC: pos./neg. logic)

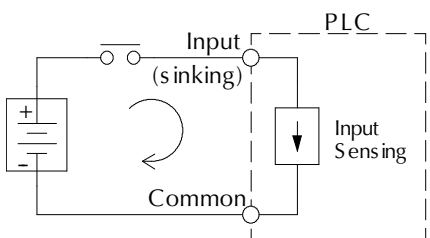
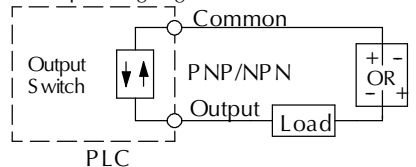

Field device examples - 3 wire connections

**NPN (Sinking)
Field Device Example**

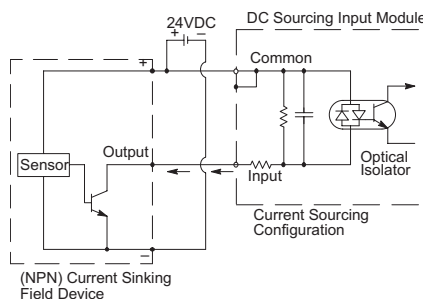

**PNP (Sourcing)
Field Device Example**

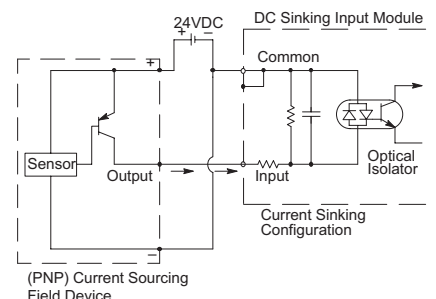

Sinking and Sourcing Concepts

Common terminals and how to use them

In order for a PLC I/O circuit to operate, current must enter at one terminal and exit at another. This means at least two terminals are associated with every I/O point. In the figure at the right, the input or output terminal is the main path for the current. One additional terminal must provide the return path to the power supply. Together, the main path and the return path create a loop, or a *complete circuit* for current to flow.

If there was unlimited space and budget for I/O terminals, then every I/O point could have two dedicated terminals. However, providing this level of flexibility is not practical or even necessary for most applications. So, most input or output points on PLCs are in groups that share the return path (called *commons*). The figure at the right shows a group (or bank) of four input points that share a common return path. In this way, the four inputs require only five terminals instead of eight.

NOTE: Assuming all input circuits have a similar resistance, the current at the common terminal is four times greater than the current at any one of the inputs. This effect is especially important to note for output circuits, where the current through a common terminal can reach several amperes. You will need to decide whether to fuse each output point individually, or to put a fuse in the common terminal path.

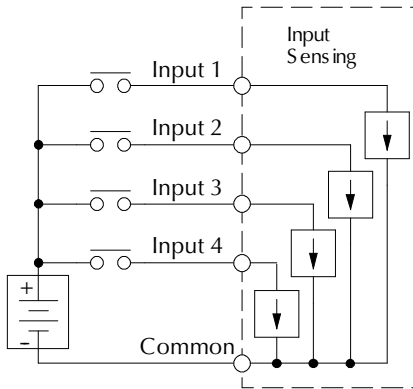
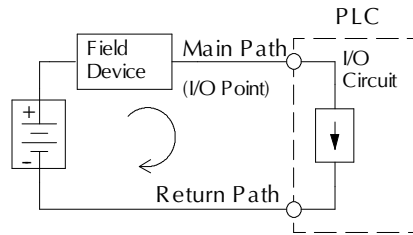

grouped into banks that share a common return path. The best indication of I/O common grouping is on the wiring label. Sample DL05, DL06 and DL105 wiring labels and their meanings are shown below.

Wiring labels and how to interpret them

DL205, DL305, DL405 - Most DL205, DL305 and DL405 input and output modules group their I/O points into banks that share a common return path. The best indication of I/O common grouping is on the wiring label, such as the one shown at the right. The miniature schematic shows two circuit banks with eight input points in each. The common terminals are labeled "CA" and "CB," respectively.

In the wiring label example, the positive terminal of a DC supply connects to the common terminals. Some of the symbols you will see on wiring labels and their meanings are shown at the right.

DL05/DL06/DL105 — Most DL05, DL06 and DL105 input and output circuits are

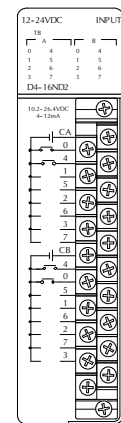
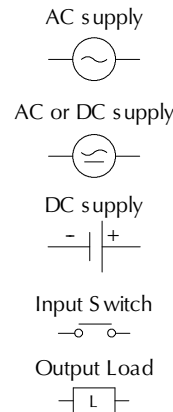

DL405 input module shown

I/O Common Grouping Bar (DL105)



Two banks of four inputs and one bank of two (DL105)

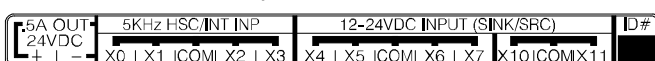

Two banks of four inputs and two banks of three outputs (DL05)

AC(I)	AC(N)	C0	X1	X3	X4	X6	C2	Y1	Y3	Y5	
	GND	LG	X0	X2	C1	X5	X7	Y0	Y2	Y4	C3

Input Bank (DL05)

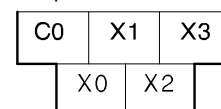

ISO 9001/UL/CUL/EU/RoHS

Throughout the world, there is a wide variety of regulatory codes, agency approvals, and other types of certification that may be required in order to install an automation system. These requirements vary and depend on your exact location and situation. For example, there may be national codes, state and local government codes, and even wide-ranging requirements such as the European Union (EU) Directives. The following are some of these codes and requirements, and explanations of how they may affect you as a PLC and industrial controls user.

ISO 9001

Some companies require their suppliers to use products that are built by companies that adhere to a documented set of quality-related procedures. ISO 9001 is one of the standards in the ISO 9000 family of standards for quality management systems. Koyo Electronics Industries Company, Ltd., the manufacturer of most of our PLC products, is an ISO 9001 certified company, as are many of our other Federation members. Some copies of the ISO certificates are available on our Web site.

Underwriters Laboratories (UL/CUL)

Underwriters Laboratories is one of the world's premier safety testing and certification sources. Many applications require UL approval for insurance and/or other compliance purposes. There are several areas of interest, but the most applicable are: UL508, the standard for Industrial Control Equipment; and UL1604, the standard covering Hazardous Locations. For more information on the Underwriters Laboratories, check their Web site at www.ul.com. There are several tables in this section that show which of our products have a UL listing. (They also indicate the cUL approval, which is required in many applications in Canada.) Please check our Web site for the most current information.

European Union (EU) Directives

This area of certification and approval is absolutely vital to anyone who wants to do business in Europe. One of the key tasks that faced the EU member countries and the European Economic Area (EEA) was the requirement to bring several similar, yet distinct, standards together

into one common standard for all members. The primary purpose of a single standard was to make it easier to sell and transport goods between the various countries and to maintain a safe working and living environment. The Directives that resulted from this "harmonization" of standards are now legal requirements for doing business in Europe. Products that meet these Directives are required to have a CE mark to signify compliance. A few key questions are always asked when the subject of CE is discussed.

Which Directives apply to me? Several Directives apply to our products, and Directives may be amended or added, as required.

- **Electromagnetic Compatibility Directive (EMC)** – Provides a means to ensure that products placed on the market do not generate electromagnetic disturbances that would affect other apparatus, including radio and/or telecommunications equipment.
- **Machinery Safety Directive** – Covers the safety aspects of the equipment, installation, etc. There are several areas involved, including testing standards covering both electrical noise immunity and noise generation.
- **Low Voltage Directive** – Is also safety related and covers electrical equipment that has voltage ranges of 50-1,000 VAC and/or 75-1,500 VDC.
- **Battery Directive** – Covers the production, recycling, and disposal of batteries.

Who is responsible for ensuring compliance with these Directives? Ultimately, we are all responsible for our various pieces of the puzzle. Manufacturers must test their products and document any test results and/or installation procedures necessary to comply with the Directives. As a machine builder, you are responsible for installing the products in a manner that will ensure compliance is maintained. You are also responsible for testing any combinations of products that may (or may not) comply with the Directives when used together. The end user of the products must comply with any Directives that may cover maintenance, disposal, etc. of equipment or various components. Although we strive to provide the best assistance available, it is impossible for us to test all possible configurations of the products we carry with respect to any specific Directive. Because of this, it is ultimately your responsibility to ensure that your machinery (as a whole) complies with these Directives and to keep up with applicable Directives and/or practices

that are required for compliance.

Which programmable controller products carry the CE label? See Tables on pp. 35-11 through 35-14 for controller systems manufactured by Koyo Electronics Industries, Host Engineering or FACTS Engineering. When properly installed and used, the approved components conform to the Electromagnetic Compatibility (EMC), Low Voltage Directive, and Machinery Directive requirements of the standards on the next page.

EC 61000-3-2 Power Factor Correction

The IEC 61000-3-2 standard is intended to reduce the amount of disturbance a device feeds back into its power source. AutomationDirect power supplies all carry the CE mark. Normally, 61000-3-2 is met or does not apply. Only our PS24-150D and PS24-300D could potentially be used in a manner not compliant with the 61000-3-2 standard.

RoHS

The Restriction of Hazardous Substances (RoHS) Directive 2002/95/EC [1] was adopted in February 2003 by the EU. The RoHS directive, which took effect July 1, 2006, restricts the use of six hazardous materials in the manufacture of various types of electrical and electronic equipment. RoHS is linked with the Waste Electrical and Electronic Equipment Directive (WEEE) 2002/96/EC which sets collection, recycling and recovery targets for electrical goods and is part of a legislative initiative to solve the problem of large amounts of toxic e-waste.

Each EU member state will adopt its own enforcement and implementation policies using the directive as a guide. Therefore, there could be as many different versions of the directive as there are states in the EU.

RoHS is often referred to as the lead-free directive, however, it restricts the use of the following six substances:

- Lead
- Mercury
- Cadmium
- Hexavalent chromium (chromium VI or Cr 6+)
- Polybrominated biphenyls (PBB)
- Polybrominated diphenyl ether (PBDE)

For a listing of all products and their compliance status see:

<http://support.automationdirect.com/compliance.html#rohs>

EU - European Union

• EMC Directive Standards Relevant to PLCs

EN50081-1 – Generic emission standard for residential, commercial, and light industry

EN50081-2 – Generic emission standard for industrial environment

EN50082-1 – Generic immunity standard for residential, commercial, and light industry

EN50082-2 – Generic immunity standard for industrial environment

• Low Voltage Directive Standards Applicable to PLCs

EN61010-1 – Safety requirements for electrical equipment for measurement, control, and laboratory use

• Product Specific Standard for PLCs

EN61131-2 – Programmable controllers, equipment requirements and tests. This standard replaces the above generic standards for immunity and safety. However, the generic emissions standards must still be used in conjunction with the following standards:

EN 61000-3-2 – Harmonics

EN 61000-3-2 – Fluctuations. We are currently in the process of changing our testing procedures from the generic standards to the product specific standards.

We do have separate Declarations of Conformity that cover the specific products and part numbers approved. Not all of the products have been labeled for CE as of this writing, so you should check the tables on the following pages to be sure. Please also check our Web site for the most up-to-date information on CE approvals or to obtain copies of our Declarations of Conformity.

Are there any special requirements necessary when using controller equipment?

Yes, the installation requirements to comply with the requirements of the Machinery Directive, EMC Directive and Low Voltage Directive are slightly more complex than the normal installation requirements found in the United States. First, check the Declaration for specific application conditions required.

Then, refer to the following manual:

- **DA-EU-M** – EU Installation Manual that covers special installation requirements to meet the EU Directive requirements. You should download the manual from our Web site to obtain the most current information. The manual is available for download at: support.automationdirect.com/compliance.html

Finally, check your user manual for EU information.

Are there any other sources of information? Although the EMC Directive gets the most attention, other basic Directives, such as the Machinery Directive and the Low Voltage Directive, also place restrictions on the control panel builder. Because of these additional requirements, it is recommended that the following publications be purchased and used as guidelines:

- BSI publication TH42073: February 1996 – Covers the safety and electrical aspects of the Machinery Directive
- EN60204-1:1992 – General electrical requirements for machinery, including Low Voltage and EMC considerations
- IEC 1000-5-2: EMC earthing and cabling requirements
- IEC 1000-5-1: EMC general considerations

It may be possible for you to obtain this information locally. However, the official source of applicable Directives and related standards is:

The Office for Official Publications of the European Communities at www.europa.eu.int

Another source is:

Global Engineering Documents

15 Inverness Way East
Englewood, CO 80112-5776
1(800) 854-7179 (within the U.S.)
(303) 397-7956 (international)
(303) 397-2740 (fax)

www.global.ihs.com

The information contained in this section is intended as a guideline and is based on our interpretation of the various standards and requirements. Since the actual standards are issued by other parties and in some cases Governmental agencies, the requirements can change over time without advance warning or notice. Changes or additions to the standards can possibly invalidate any part of the information provided in this section.

Books

Following is a list of books that may be helpful to you:

Title: **EMC For Systems and Installations**

Authors: Tim Williams and Keith Armstrong
Publisher: Newnes
Woburn, MA

Title: **CE From A to Z**

Authors: Mette Winther Pedersen & Gert Bukkjaer
Publisher: Levison & Johnson & Johnson a/s
Denmark

Title: **EU Directive Handbook: Understanding the European Union Compliance Process and What it Means to You**

Authors: Allen R. Bailey & Melinda C. Bailey
Publisher: St. Lucie Press
Boca Raton, FL

Title: **Practical Guide to the Low Voltage Directive**

Authors: Gregg Kervill
Publisher: Newnes
Woburn, MA

Title: **C E Marking Handbook: A Practical Approach to Global Safety Certification**

Authors: David Lohbeck
Publisher: Newnes
Woburn, MA

NEC and NEMA

The National Electrical Code (NEC)

NEC provides regulations concerning the installation and use of various types of electrical equipment.

These classifications are being "harmonized" with the IEC and European Hazardous Location Ratings. A source of information about this "harmonization" is the Instrument Society of America (ISA).

Contact the ISA at:
 67 Alexander Drive
 RTP, NC 27709
 Phone: (919)549-8411
www.isa.org

Another resource is:
www.ul.com/hazloc

National Electrical Manufacturers Association (NEMA)

NEMA publishes many different documents that discuss standards for industrial control equipment. Please note that these standards are undergoing "harmonization" with the IEC and European standards and may be replaced. Global Engineering Documents handles the sale of NEMA, IEC and CE documents. For more information, please contact Global Information at:

1 (800) 854-7179 (within the U.S.)
 (303) 397-7956 (international)
 (303) 397-2740 (fax)
 15 Inverness Way East
 Englewood, CO 80112-5776
www.global.ihs.com

- ICS 1, General Standards for Industrial Control and Systems
- ICS 2, Controllers, Contactors, and Overload Relays, Rated no more than 2000 Volts AC or 750 Volts DC
- ICS 3, Factory Built Assemblies
- ICS 6, Enclosures for Industrial Control Systems

National Electric Code (NEC) Article 500 Hazardous Location Classification			
Class	Division	Group	
Class I Locations in which flammable gases or vapors are (or may be) present in the air in quantities great enough to produce explosive or ignitable mixtures.	DIVISION 1: Locations in which hazardous concentrations of flammable gases or vapors exist continuously, intermittently, or periodically under normal conditions. -or- Locations in which hazardous concentrations of flammable gases or vapors may exist frequently because of repair or maintenance operations or because of leakage. -or- Locations in which breakdown or faulty operation of equipment or processes might release hazardous concentrations of flammable gases or vapors. DIVISION 2: Locations in which volatile flammable liquids or flammable gases are handled, processed, or used, but are normally kept in closed containers and can only escape due to accidental rupture. -or- Locations in which hazardous concentrations of gases or vapors are normally prevented by mechanical ventilation and might become hazardous due to failure of the ventilating equipment. -or- Locations that are adjacent to Class I, Division 1 locations.	GROUP A: Atmospheres containing acetylene GROUP B: Atmospheres containing: acrolein (inhibited) butadiene ethylene oxide hydrogen gases containing more than 30% hydrogen by volume propylene oxide GROUP C: Atmospheres containing: allyl alcohol carbon monoxide cyclopropane diethyl ether ethylene hydrogen sulfide methyl ether n-propyl ether or gases or vapors of equivalent hazard	GROUP D: Atmospheres containing: acetone ammonia benzene butyl alcohol ethane ethyl alcohol gasoline heptanes hexanes methane (natural gas) methyl alcohol methyl ethyl ketone (MEK) naphtha octanes pentanes propane styrene toluene xylenes or gases or vapors of equivalent hazard
Class II Locations in which there are explosive mixtures of air and combustible dust.	DIVISION 1: Locations in which explosive or ignitable amounts of combustible dust are or may be in suspension of continuously, intermittently, or periodically under normal operating conditions. -or- Locations where mechanical failure or abnormal operation of machinery or equipment might cause explosive or ignitable mixtures to be produced. -or- Locations in which combustible electrically conductive dust is present. DIVISION 2: Locations where combustible dust deposits exist but are not likely to be thrown into suspension in the air, but where the dust deposits may be heavy enough to interfere with safe heat dissipation from electric equipment. -or- Locations where combustible dust deposits may be ignited by arcs, sparks, or burning material from electrical equipment.	GROUP E: Atmospheres containing combustible: metal dusts regardless of resistivity or dusts of similarly hazardous characteristics having resistivity of less than 100,000 ohm-centimeter GROUP F: Atmospheres containing combustible: carbon black, charcoal, or coke dusts which have more than 8% total volatile material or carbon black, charcoal, or coke dusts sensitized by other materials so that they present an explosion hazard, and having a resistivity greater than 100 ohm-centimeter but equal to or less than 100,000,000 ohm-centimeter GROUP G: Atmospheres containing dusts having resistivity of 100,000,000 ohm-centimeter	
Class III Locations in which there is the presence of easily-ignited fibers or flyings, but where the fibers or flyings are not likely to be in suspension in the air in quantities great enough to produce ignitable mixtures.	DIVISION 1: Locations in which easily ignitable fibers or materials producing flyings are handled, manufactured, or used. DIVISION 2: Locations in which easily ignitable fibers are stored or handled (except in a manufacturing process).	(NOT GROUPED) Manufacturers include: textile mills, clothing plants, and fiber processing plants. Easily ignitable fibers include: Cotton, rayon, sisal, hemp, and jute.	

NEMA Electrical Enclosure Environmental Protection Ratings			
Type	Protection	Location	Description
1	General purpose	Indoor	Accidental contact
2	Drip-proof	Indoor	Falling non-corrosive liquids and falling dirt (dripping and light splashes)
3	Dust-tight, rain-tight	Outdoor	Windblown dust, water, and sleet; ice-resistant
3R	Dust-tight, rain-tight	Outdoor	Same as above, plus melting of sleet/ice will not damage external enclosure or mechanisms
4	Water-tight/dust-tight	Indoor/ outdoor	Splashing water, outdoor seepage of water, falling or hose-directed water
4X	Water-tight/dust-tight	Indoor/ outdoor	Same as above, plus corrosion resistant
5	Dust-tight	Indoor	Dust and falling dirt
6	Water-tight/dust-tight	Indoor/ outdoor	Temporary entry of water limited submersion, formation of ice on enclosure
6P	Water-tight/dust-tight	Indoor/ outdoor	Same as previous, plus prolonged submersion
7	Explosion proof/Class I Group D Hazardous Locations	Indoor	Hazardous chemicals and gases
9	Explosion proof/Class II Hazardous Locations	Indoor	Hazardous dust
11	Drip-proof/corrosion Resistant	Indoor	Oil immersion, corrosive effects of liquids and gases
12	Drip-tight/dust-tight	Indoor	Fibers, lint, dust, and splashing, and dripping condensation of non-corrosive liquids
13	Oil-tight/dust-tight	Indoor	Dust, spraying of water, oil, and non-corrosive coolant

How to interpret IP Ratings

The first number defines the degree of protection against penetration of **solid objects** into the housing.

The second number defines the degree of protection against penetration of **liquid** into the housing.

IP-67 (sample IP rating)

First Number	Level of Protection
X	Not evaluated
0	No protection against contact or entry of solids
1	Protection against accidental contact by hand, but not deliberate contact. Protection against large foreign objects. 1: \geq 50mm 2: \geq 12.5mm 3: \geq 2.5mm 4: \geq 1.0mm
2	Protection against contact by fingers. Protection against medium-size foreign objects. 1: \geq 50mm 2: \geq 12.5mm 3: \geq 2.5mm 4: \geq 1.0mm
3	Protection against contact by tools, wires, etc. Protection against small foreign objects.. 1: \geq 50mm 2: \geq 12.5mm 3: \geq 2.5mm 4: \geq 1.0mm
4	Protection against contact by small tools and wires. Protection against small foreign objects.. 1: \geq 50mm 2: \geq 12.5mm 3: \geq 2.5mm 4: \geq 1.0mm
5	Complete protection against contact with live or moving parts. Protection against harmful deposits of dust.
6	Complete protection from live or moving parts. Protection against penetration of dust.

Second Number	Level of Protection
X	Not evaluated
0	No Protection
1	Protection against drops of condensed water. Condensed water falling on housing shall have no effect.
2	Protection against drops of liquid. Drops of falling liquid shall have no effect when housing is tilted to 15° from vertical.
3	Protection against rain. No harmful effect from rain at angles less than 60° from vertical.
4	Protection against splashing from any direction.
5	Protection against water jets from any direction.
6	Protection against conditions on ships and decks. Water from heavy seas will not enter.
7	Protection against immersion in water. Water will not enter under stated conditions of pressure and length of time.
8	Protection against indefinite immersion in water under a specified pressure.
8K	Protection against indefinite immersion in water under a specified pressure.
9	Protection against indefinite immersion in water under a specified pressure.
9K	Protection against high-pressure/steam-jet cleaning.

Additional information on IP ratings can be found in the 1976 IEC Publication: Classification of Degrees of Protection Provided by Enclosures or at www.iec.ch. Example: What is IP-67? Complete protection of live parts, protection against the penetration of dust. Additionally, protection while immersed in water.

IEC Utilization Categories

IEC Utilization Categories for Low Voltage Switchgear and Control Gear				
Current	Category	Typical Applications	Relevant IEC Product Standard	
AC	AC-1	Non inductive or slightly inductive loads, resistance furnaces, heaters	60947-4	
	AC-2	Slip-ring motors: switching off		
	AC-3	Squirrel-cage motors: starting, switching off motors during running most typical industrial application		
	AC-4	Squirrel-cage motors: starting, plugging (1), inching (2)		
	AC-5a	Switching of electric discharge lamps		
	AC-5b	Switching of incandescent lamps		
	AC-6a	Switching of transformers		
	AC-6b	Switching of capacitor banks		
	AC-7a	Slightly inductive load in household appliances: mixers, blenders		
	AC-7b	Motor-loads for household applications: fans, central vacuum		
	AC-8a	Hermetic refrigerant compressor motor control with manual resetting overloads		
	AC-8b	Hermetic refrigerant compressor motor control with automatic resetting overloads		
	AC-12	Control of resistive loads and solid state loads with opto-coupler isolation		60947-5
	AC-13	Control of solid state loads with transformer isolation		
	AC-14	Control of small electromagnetic loads		
AC-15	Control of AC electromagnetic loads	60947-3		
AC-20	Connecting and disconnecting under no-load conditions			
AC-21	Switching of resistive loads, including moderate loads			
AC-22	Switching of mixed resistive and inductive loads, including moderate overloads			
AC-23	Switching of motor loads or other highly inductive loads			
AC and DC	A	Protection of circuits, with no rated short-time withstand current	60947-2	
	B	Protection of circuits, with a rated short-time withstand current		
DC	DC-1	Non-Inductive or slightly inductive loads, resistance furnaces, heaters	60947-4	
	DC-3	Shunt-motors, starting, plugging (1), inching (2), dynamic breaking of motors		
	DC-5	Series-motors, starting, plugging (1), inching (2), dynamic breaking of motors		
	DC-6	Switching of incandescent lamps		
	DC-12	Control of resistive loads and solid state loads with opto-coupler isolation	60947-5	
	DC-13	Control of DC electromagnetics		
	DC-14	Control of DC electromagnetic loads having economy resistors in the circuit		
	DC-20	Connecting and disconnecting under no-load conditions	60947-3	
	DC-21	Switching of resistive loads, including moderate overloads		
	DC-22	Switching of mixed resistive and inductive loads, including moderate overloads (i.e., shunt motors)		
DC-23	Switching of highly inductive loads (i.e., series motors)			

Wiring Devices – NEMA Wiring Diagrams

Reference material only. Please see Wiring Section in the catalog for product part number.

2-Pole 2-Wire

125V

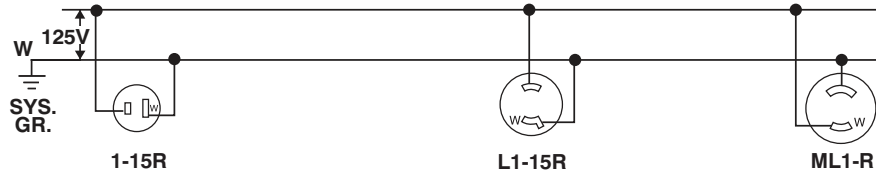

208V or 250V

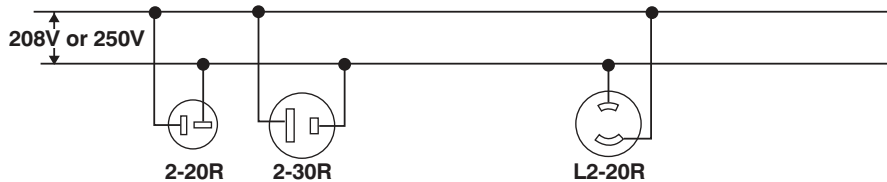

2-Pole 3-Wire Grounding

125V

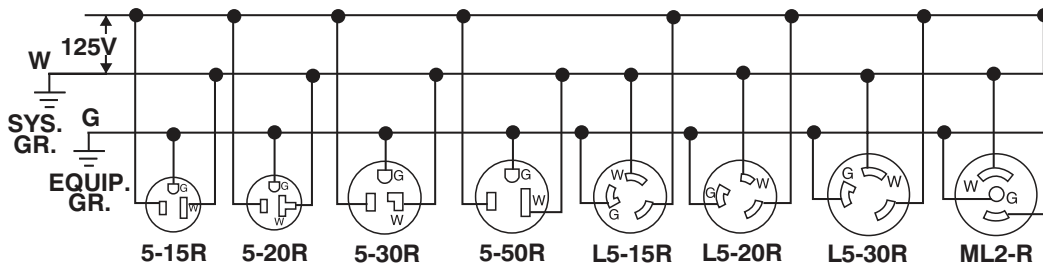

208V or 250V

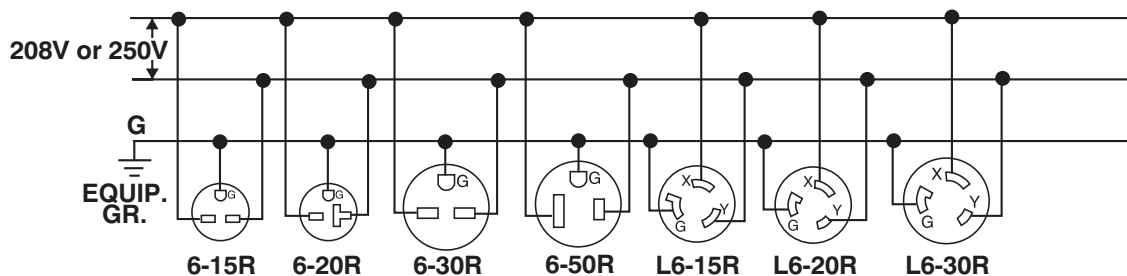

277V AC

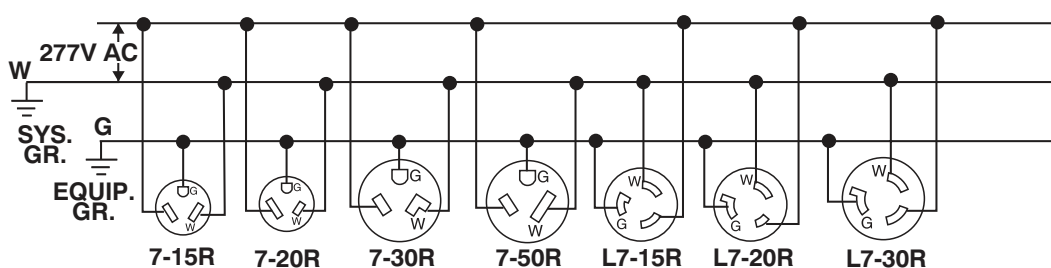

Wiring Devices – NEMA Wiring Diagrams

2-Pole 3-Wire Grounding

480V AC

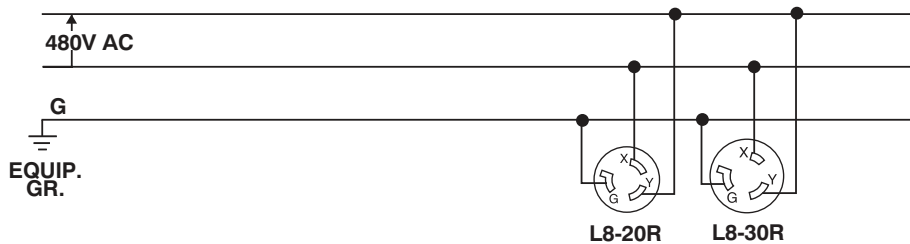

600V AC

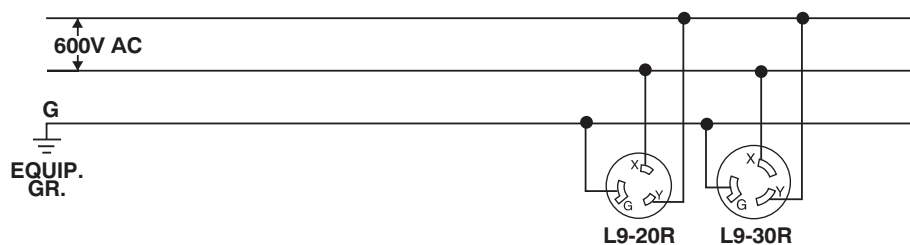

3-Pole 3-Wire

125V/250V AC

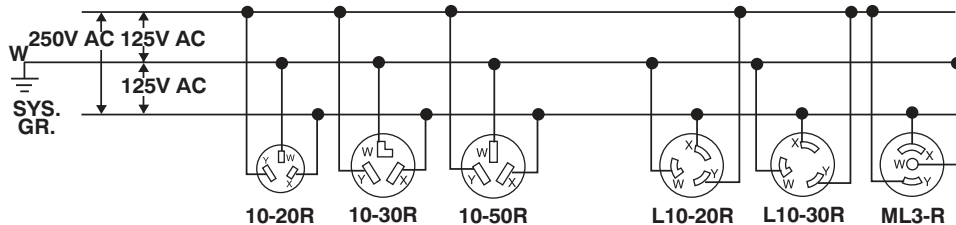

3 ϕ 250V AC

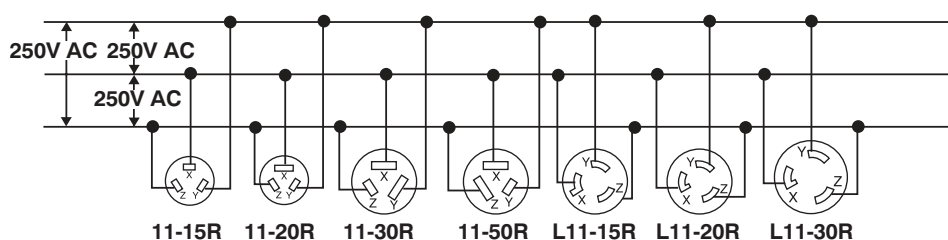

3 ϕ 480V AC

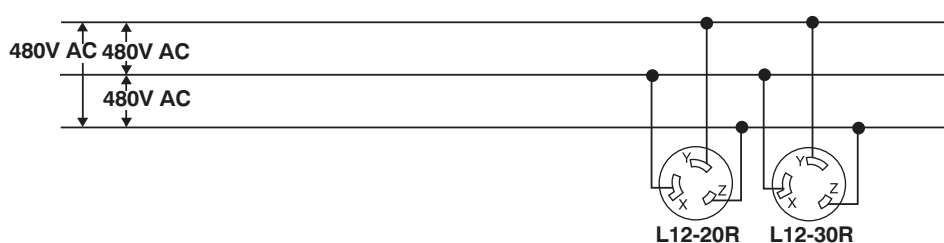

Wiring Devices – NEMA Wiring Diagrams

3-Pole 3-Wire Continued

3Ø 600V AC

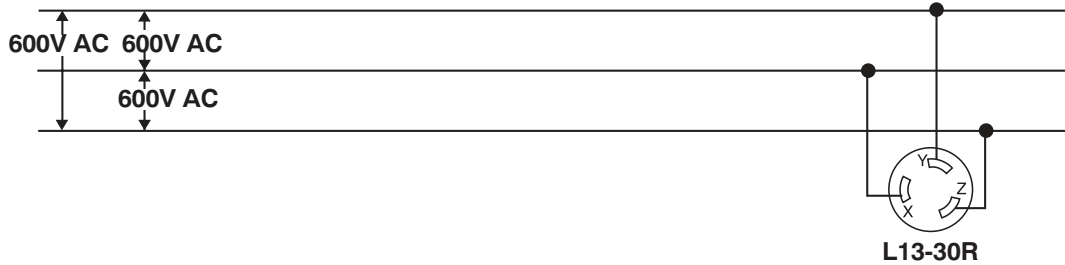

3-Pole 4-Wire Grounding

125/250V AC

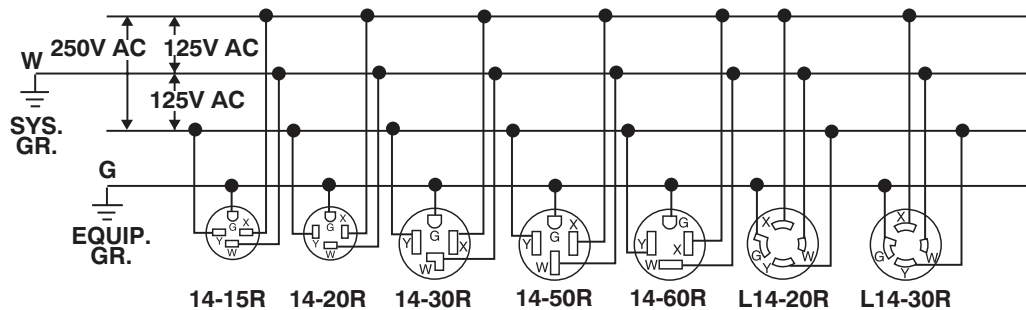

3Ø 250V AC

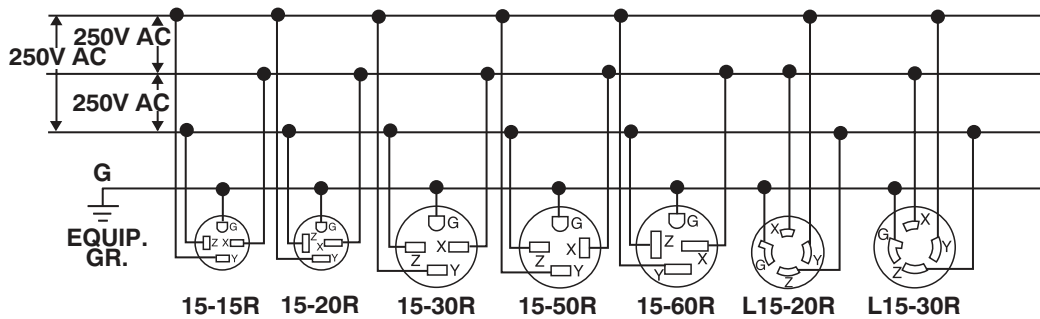

3Ø 480V AC

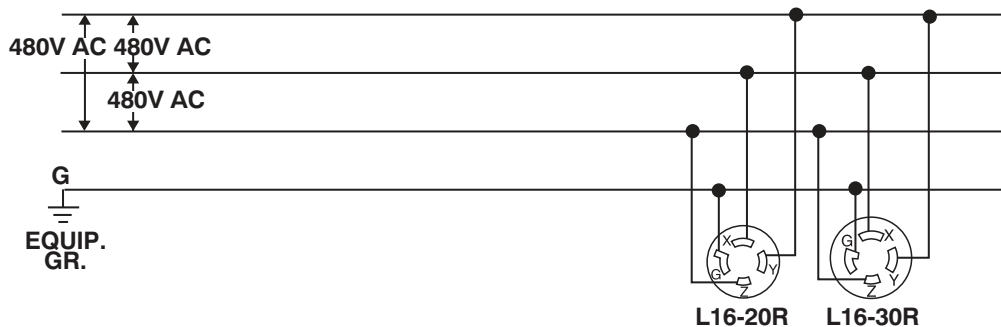

Wiring Devices – NEMA Wiring Diagrams

3-Pole 4-Wire Grounding Continued

3 ϕ 600V AC

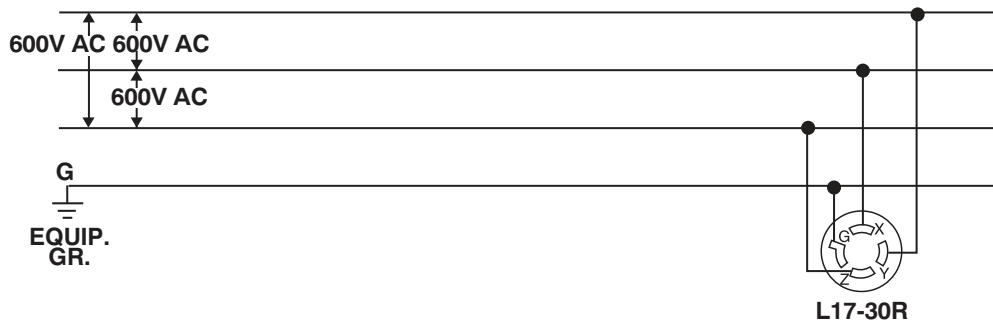

4-Pole 4-Wire

3 ϕ Y 120/208V AC

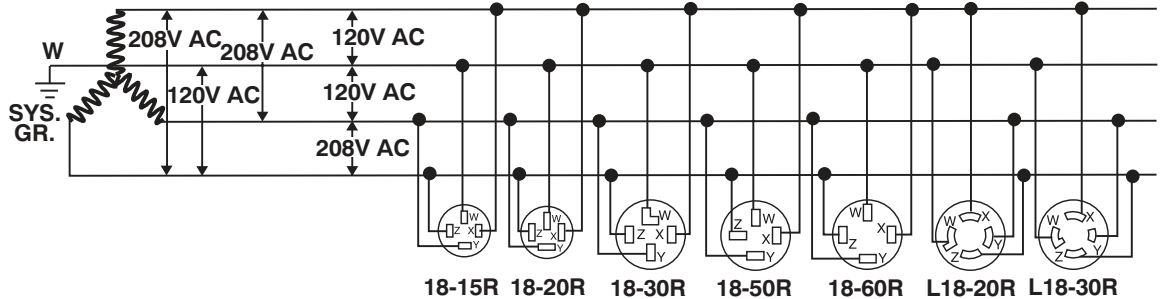

3 ϕ Y 277/480V AC

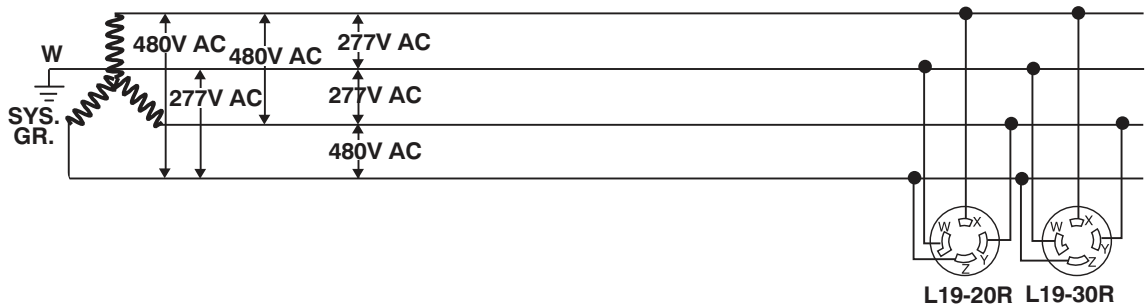

3 ϕ Y 347/600V AC

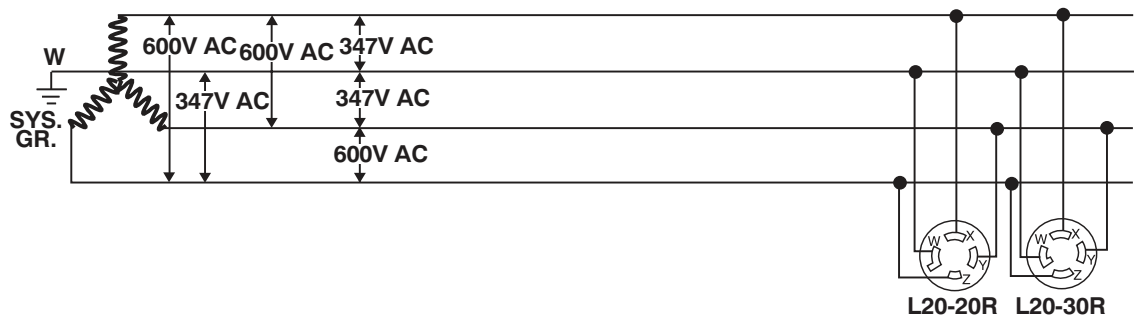

Wiring Devices – NEMA Wiring Diagrams

4-Pole 5-Wire Grounding

3 ϕ Y 120/208V AC

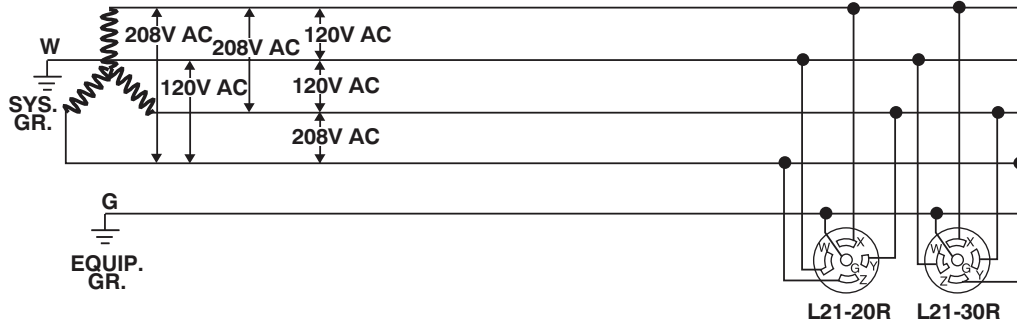

3 ϕ Y 277/480V AC

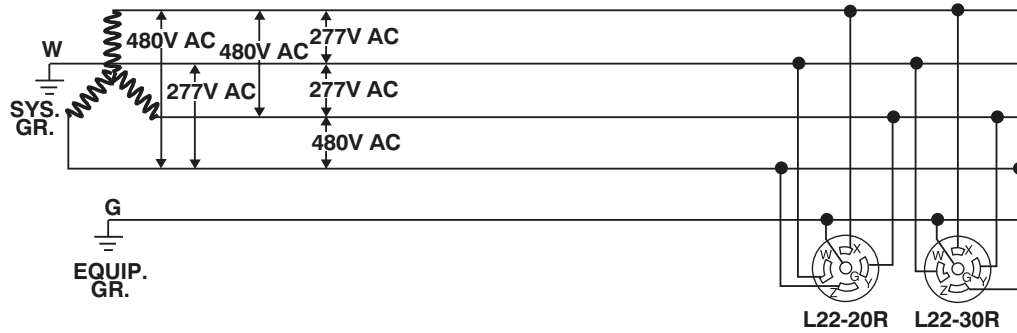

3 ϕ Y 347/600V AC

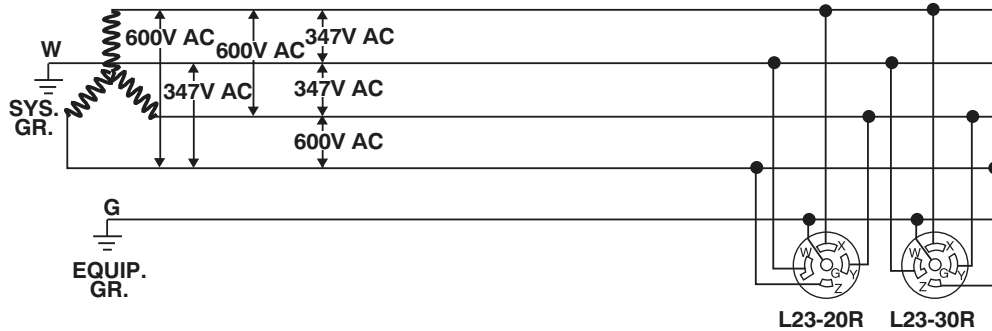

UL/CUL/CSA Certification Numbers

UL/CUL/CSA Certification Numbers ¹			
Name	UL/CUL	CSA	ISO-9000
Accuamp Current Sensors, Switches, Transducers	E222847	-	-
ADC 22mm Pushbuttons and Indicating Lights ECX/GCX models	E189258	66746	-
ADC Contactors	E191059	703171	✓
ADC CTT Series Counter/Timer/Tach	E311366	-	-
ADC Foot Switches	E191072	-	-
ADC GS & DURAPULSE Drives	E198015	-	-
ADC Limit Switches	E191072	-	✓
ADC Line Reactors - GS series	E61431	-	-
ADC Line Reactors - LR series	E197592	-	-
ADC Manual Motor Controllers	E195426	-	✓
ADC Photo Sensors	E130644, E224302, E187310	-	✓
ADC LED Photo Sensor Cables	E191684	-	-
ADC Power Supplies (FA Series)	E200031	-	-
ADC Power Supplies (PS & PSE series) ²	E197592, E198298, E197886	-	✓
ADC Power Supplies (PSM series)	E197592, E198298	229285	✓
ADC Power Supplies (PSS series)	E198298	-	-
ADC Power Supplies (PSB series)	E197592, E198298	249074	-
ADC Power Supplies (PSP, PSC series) ³	E197592, E198298	-	✓
ADC Proximity Switches	E130644, E187310, E328611	-	✓
ADC Relays - QL and QM Series	E222847	218218	-
ADC Relays - 75, 78 and PR40 Series	E191059	244610	-
ADC Relays - 755 Series	E43641	244610	-
ADC Relays - RS Series	E44592	-	-
ADC Relays - SSR2, SSR6, SSR8 Series	E222847	244610	-
ADC Relays - HSSR8 Series	E344125	-	-
ADC Telephone Modems and Ethernet Switches	E200031	-	-
Atlas Industrial Monitors	E313546, E191072	-	-
BM Cable Ties ⁴	E223175	-	-
Bryant Plugs	E1381	16215	-
Bryant Connectors	E3381, E3382	16215	-
Bryant Receptacles	E2258	16215	-
Bryant Cover Plates	E31999	18416	-
Bryant Manual Motor Controllers	E70402	46186	-
C-more Panels	E157382	-	-
C-more Micro Panels	E157382	-	-
Cirronet RF Modems	E235438	-	-
CLICK PLCs	E157382, E316037	-	✓
Comepi Safety Limit Switches	E189258	176294	-
Contrinex Light Curtains	E321951	-	-
Cutler-Hammer Pushbuttons	E131568	68551	-
Cutler-Hammer Contactors	E1491	353	-
DIN ectors (DN-SP-xx series only)	E320462	-	-
DIN ectors (all other products)	E179129	-	-
Direct .LOGIC PLC hazardous locations	E200031	-	✓ (Koyo)
Direct .LOGIC PLCs & I/O	E157382	-	✓ (Koyo)
Direct touch Panels	E178572	-	✓
Dold Safety Relays	E107778	-	-
Eaton Supplementary Protectors (WMZS)	E162396	245545	-
Eaton Miniature Circuit Breakers (WMZT)	E7819, E64983	245545	-

UL/CUL/CSA Certification Numbers ¹			
Name	UL/CUL	CSA	ISO-9000
Edison Fuse Blocks (Class T)	E14853	47235	-
Edison Fuse Holders - CH	E14853	-	-
Edison Fuses	E19180, E162363, E162443	053787, 227483, 700489	-
Edison Power Distribution Blocks	E256146, E221592, E333541	700490, 700489	-
Encore Wire Type THHN	E123774, E156879	-	-
Encore Wire Type MTW	E156879	-	-
Encore Wire Type TFFN	E156878	-	-
Ethernet Patch Cable	E148114	-	-
Ethernet Patch Cable Connector	E205572	-	-
FACTS I/O Modules	E139594, E200031	-	-
Ferraz Shawmut Fusible and Non-Fusible Disconnects	E191605, E258428	703166	-
Ferraz Shawmut Disconnects Shafts and Handles (SH400-15 = Socomec 379H1540)	E191605, E196672, E201138	703166	-
Ferraz Shawmut Disconnects Accessories (Connectors and Lugs)	E191605	703166	-
TL100 = Brumall 2/0 TP	E61509	026192_0_000, 703166	-
TL200 = Brumall 3/0 TP	E61509	026192_0_000, 703167	-
TL400 = Brumall 600T-2 / CMC PV2-600	E61509, E26130	030117_C_000, 703166, 026192_0_000	-
TL600 = Brumall 600T-2 / CMC PV2-600	E61509, E26130	030117_C_000, 703166, 026192_0_001	-
TL800 = CMC PV3-600	E26130	030117_C_00, 703168	-
AC3= Socomec 39990701	E191127	703166	-
AC4= Socomec 39990702	E191127	703166	-
Flexible Cord, Types SJE00W/SE00W	E46194	224650	-
Flexible Cord, Type W	E308664	236844	-
Fuji Molded Case Circuit Breakers:	E90584	-	-
Fuji MCCB Accessories:	E93289	-	-
Fuji Motor Controls	E44592, E93289	20479	✓
Fuji Manual Motor Starters (stand-alone)	E163944	-	-
Fuji Manual Motor Starter w/ Fuji contactor	E211710	-	-
Fuji Pushbuttons	E44592	LR20479	-
Fuji Timers and Card Relays	E44592	-	✓
Fuse Blocks	E14853	47235_C_000	-
Fuses (Class CC)	E162363	700489	-
Fuses (Midget Class)	E162443	700489	-
Fuses (Class J)	E162363	700489	-
Fuses (Class RK5)	E162363	700489	-
Fuses (Class RK1)	E162363	700489	-
Fuses (Class T) Edison	E162363	53787	-
Fuses (General Purpose-Small Electronic)	E19180	227483053787_C_000	-
Gladiator Switches Open Type (Class CC)	E339079	-	-
Gladiator Switches Industrial Control Type (Class Midget)	E222847	-	-

Continued on next page.

Footnotes on next page.

UL/CUL/CSA Certification Numbers

Company Information

Systems Overview

Programmable Controllers

Field I/O

Software

C-more & other HMI

Drives

Soft Starters

Motors & Gearbox

Steppers/Servos

Motor Controls

Proximity Sensors

Photo Sensors

Limit Switches

Encoders

Current Sensors

Pressure Sensors

Temperature Sensors

Pushbuttons/Lights

Process

Relays/Timers

Comm.

Terminal Blocks & Wiring

Power

Circuit Protection

Enclosures

Tools

Pneumatics

Safety

Appendix

Product Index

Part # Index

UL/CUL/CSA Certification Numbers ¹			
Name	UL/CUL	CSA	ISO-9000
Hammond Control Transformers	E50394	003902	-
Hammond Encapsulated Transformers	E50394	003902	
Hitachi Drives	E178241	-	✓
H/W Filter Fan Kits WPF Series (PFANNENBERG PF Series)	E175229	-	-
H/W Metal Cabinet & Cutout Boxes	E6924	66078	-
H/W Metal Industrial Control Panels (Non- disconnect)	E64791	66078	-
H/W Metal Industrial Control Panels (Disconnect)	E64791	66078	-
H/W Metal Junction & Pull Boxes	E23553	66078	-
H/W Metal Wireway & Fittings	E32576	66078	-
H/W Non-Metal Enclosures	E64791	222873	-
Host Products	E185989	-	-
I-Flex Flexible Liquid-Tight Tubing (NMPT)	E311916	-	-
IronHorse Motors (T-Frame, TC-Frame)	-	200895 215302	✓
IronHorse Motors (Rolled Steel)	-	215302	-
IronHorse Motors (DC)	-	247070	-
Koyo Timers	E186879	-	✓
Koyo Encoders	E189395	-	✓
Koyo Proximity Switches	E186879	-	✓
Marathon Motors	E49747	37479 002025	-
MCCB (molded case circuit breakers)	E7819 E64983	43556	-
MCCB Field Installed Accessories	E64983	-	-
Murr Field Wireable Connectors T-Couplers	E224242 E325311	-	-
Nitra Cylinder Switches	E328811	-	-
Non-Fused Disconnects	E226699	-	-
Optimate Panels	E182843	-	-
Productivity3000 PAC and I/O ⁵	E157382 E200031	-	-
ProSense Pressure Sensors	E320431	-	-
ProSense QPS Pressure Switch	E157382	-	-
ProSense Temperature Sensors	E324411	-	-
Signal Conditioners: FC Series	E200031	-	-
Signal Conditioners: Universal	E314521	-	-
Solo Process Controllers	E311366	-	-
Stratus Air Conditioners	SA33404	-	-
Stride Ethernet Switches	E200031	-	-
Stellar SR22 Compact Soft Starters	E333109	-	-
Stellar SR22 Soft Starter Accessory Cooling Fans	E89936 E132139 E77551	-	-
Stellar SR33 Basic Soft Starters	E333109	-	-
Stellar SR44 Full-Featured Soft Starters	E333109	-	-
SureServo Servo Systems - Drives	E198015	-	-
SureServo Servo Systems - Motors	E245050	-	-

UL/CUL/CSA Certification Numbers ¹			
Name	UL/CUL	CSA	ISO-9000
Werma Signaltechnik	E164155	-	✓
Wire Duct	E123572	-	-
ZipLinks: FACTS Communication Adapters and all Cables ⁶	E200031	-	-
ZipLinks: FACTS Relay Modules	E157382	-	-
ZipLinks: FACTS Replacement Relays	E141060	-	-
ZipLinks: Non-FACTS Cables ⁷	E179771	80671	-
ZipLinks: Non-FACTS Connectors ⁷	E197592	-	-
ZipPort Junction Blocks	E328610	-	-
ZipPort Multi-Wire	E342543	-	-
ZipPort Panel Interface Connectors	E329932	-	-

Other Registrations and Certifications	
Name/Description	Designation
ITAR Part 122 - Registration of Manufacturers and Exporters, registered with Office of Defense Trade Controls	22CFR Section122

Footnotes

¹For the latest agency approvals information please see our Website: <http://www.automationdirect.com/static/specs/agencyapprovals.pdf>

²PSxx-050D and PS24-500D are not UL/cUL 1604 listed.

³PSP05-020S, PSP12-024S and PSP24-240S are not UL 60950 recognized.

⁴Except for the following parts, which are not UL approved: BM-N8912, BM-N1012, BM-R1576, BM-R2076, BM-R3076, all BM-Txxxxx, all cable mounts and hand tools.

⁵P3-16TD3P, P3-HSI and P3-HSO modules are not UL1604 E200031 recognized.

⁶The cables are listed in E200031 Vol. 5 Sec. 1; Titled: Unlisted Components Report. Included in this section are ZL-CMA15 and ZL-CMA15L as well. A copy of this section is available from ADC upon request.

⁷The manufacturer of these devices is no longer in business. Please verify listing status with UL directly at Multiple Listings Customer Service (1-877-854-3577 or mls@us.ul.com). For new projects please use ZipLinks manufactured by FACTS Engineering.

Agency Approvals

Productivity3000 Agency Approvals*				
	UL	cUL	CE	Class 1 Div 2
Bases, CPU, P3-EX, P3-RS, and I/O modules	✓	✓	✓	✓
Note 1: The P3-16TD3P, P3-HSI and P3-HSO modules are not UL1604 E200031 recognized.				

DL405 Agency Approvals*				
	UL	CUL	CE	Class 1 Div 2
CPUs				
D4-430	✓	✓	✓	
D4-440	✓	✓	✓	
D4-440DC-1	✓	✓	✓	
D4-440DC-2	✓	✓	✓	
D4-450	✓	✓	✓	
D4-450DC-1	✓	✓	✓	
D4-450DC-2	✓	✓	✓	
D4-470-xx	✓	✓	✓	
Expansion Units and Cables				
D4-EX	✓	✓	✓	
D4-EXDC	✓	✓	✓	
D4-EXCBL-1	✓	✓	✓	
D4-EXCBL-2	✓	✓	✓	
I/O Bases				
D4-04B-1	✓	✓	✓	
D4-06B-1	✓	✓	✓	
D4-08B-1	✓	✓	✓	
DC Input Modules				
D4-08ND3S	✓	✓	✓	
D4-16ND2	✓	✓	✓	
D4-16ND2F	✓	✓	✓	
D4-32ND3-1	✓	✓	✓	
D4-32ND3-2	✓	✓	✓	
D4-64ND2	✓	✓	✓	
AC Input Modules				
D4-08NA	✓	✓	✓	
D4-16NA	✓	✓	✓	
D4-16NA-1	✓	✓	✓	
AC/DC Input Modules				
D4-16NE3	✓	✓	✓	
F4-08NE3S			✓	
AC Output Modules				
D4-08TA	✓	✓	✓	
D4-16TA	✓	✓	✓	
DC Output Modules				
D4-08TD1	✓	✓	✓	
F4-08TD1S			✓	
D4-16TD1	✓	✓	✓	
D4-16TD2	✓	✓	✓	
D4-32TD1	✓	✓	✓	
D4-32TD1-1			✓	
D4-32TD2	✓	✓	✓	
D4-64TD1	✓	✓	✓	

DL405 Agency Approvals*				
	UL	CUL	CE	Class 1 Div 2
Relay Output Modules				
D4-08TR	✓	✓	✓	
F4-08TRS-1		✓	✓	
F4-08TRS-2	✓	✓	✓	
D4-16TR	✓	✓	✓	
Analog Modules				
D4-04AD	✓	✓	✓	
F4-04AD	✓	✓	✓	
F4-04ADS	✓	✓	✓	
F4-08AD	✓	✓	✓	
F4-16AD-1			✓	
F4-16AD-2			✓	
D4-02DA	✓	✓	✓	
F4-04DA	✓	✓	✓	
F4-04DAS-1	✓	✓	✓	
F4-04DAS-2			✓	
F4-08THM	✓	✓	✓	
F4-08THM-n	✓	✓		
F4-08RTD	✓	✓	✓	
F4-04DA-1	✓	✓	✓	
F4-04DA-2	✓	✓	✓	
F4-08DA-1	✓	✓	✓	
F4-08DA-2	✓	✓	✓	
F4-16DA-1	✓	✓	✓	
F4-16DA-2	✓	✓	✓	
Remote I/O				
D4-RM	✓	✓	✓	
D4-RS	✓	✓	✓	
D4-RSDC	✓	✓	✓	
D4-SM	✓	✓	✓	
D4-SS-88	✓	✓	✓	
D4-SS-106	✓	✓	✓	
D4-SS-16T	✓	✓	✓	
D4-SS-16N	✓	✓	✓	
F4-SDS	✓	✓	✓	
H4-ERM	✓	✓	✓	
H4-ERM-F	✓	✓	✓	
Communications and Networking				
D4-DCM	✓	✓	✓	
F4-MAS-MB	✓	✓	✓	
F4-SLV-MB	✓	✓	✓	
F4-SLV-TW	✓	✓	✓	
F4-SDN	✓	✓	✓	
H4-ECOM	✓	✓	✓	
H4-ECOM100				
H4-EBC	✓	✓	✓	
H4-ECOM-F	✓	✓	✓	
H4-EBC-F	✓	✓	✓	

DL405 Agency Approvals*				
	UL	CUL	CE	Class 1 Div 2
CoProcessors™				
F4-CP128-1	✓	✓	✓	
F4-CP512	✓	✓	✓	
F4-CP512-1	✓	✓		
F4-CP128-R	✓	✓		
F4-CP128-T	✓	✓	✓	
Specialty Modules				
D4-INT	✓	✓	✓	
D4-HSC	✓	✓	✓	
F4-16PID	✓	✓	✓	
F4-8MPI	✓	✓	✓	
D4-16SIM	✓	✓	✓	
F4-4LTC	✓	✓	✓	
H4-CTRIO	✓	✓		
Programming				
D4-HPP-1	✓	✓	✓	

DL305 Agency Approvals*				
	UL	CUL	CE	Class 1 Div 2
CPUs				
D3-330	✓	✓	✓	✓
D3-330P	✓	✓	✓	✓
D3-340	✓	✓	✓	✓
D3-350	✓	✓	✓	✓
Specialty CPUs				
F3-OMUX-1	✓	✓	✓	
F3-OMUX-2	✓	✓	✓	
F3-OMUX-3	✓	✓	✓	
F3-PMUX-1	✓	✓	✓	
F3-RTU-1	✓	✓	✓	✓
Bases and Cables				
D3-05B-1	✓	✓	✓	
D3-05BDC	✓	✓	✓	
D3-08B-1	✓	✓	✓	
D3-10B-1	✓	✓	✓	
D3-10BDC	✓	✓	✓	
D3-05B-NR	✓	✓	✓	✓
D3-05BDC-NR	✓	✓	✓	✓
D3-08B-NR	✓	✓	✓	✓
D3-10B-NR	✓	✓	✓	✓
D3-10BDC-NR	✓	✓	✓	✓

*For the latest information on agency approvals, check our Web site.
 UL (Underwriters Laboratories, Inc.)
 CUL (Canadian Underwriters Laboratories, Inc.)
 CE (EMC Directive, LV Directive)
 Class 1, Div 2 (Tested by Underwriters Laboratories, Inc., file no. E200031)

Agency Approvals

Company Information

Systems Overview

Programmable Controllers

Field I/O

Software

C-more & other HMI

Drives

Soft Starters

Motors & Gearbox

Steppers/ Servos

Motor Controls

Proximity Sensors

Photo Sensors

Limit Switches

Encoders

Current Sensors

Pressure Sensors

Temperature Sensors

Pushbuttons/ Lights

Process

Relays/ Timers

Comm.

Terminal Blocks & Wiring

Power

Circuit Protection

Enclosures

Tools

Pneumatics

Safety

Appendix

Product Index

Part # Index

DL305 Agency Approvals*				
	UL	CUL	CE	Class 1 Div 2
DC Input Modules				
D3-08ND2	✓	✓	✓	✓
D3-16ND2-1	✓	✓	✓	✓
D3-16ND2-2	✓	✓	✓	✓
D3-16ND2F	✓	✓	✓	✓
F3-16ND3F	✓	✓	✓	
AC Input Modules				
D3-08NA-1	✓	✓	✓	✓
D3-08NA-2	✓	✓	✓	✓
D3-16NA	✓	✓	✓	✓
AC/DC Input Modules				
D3-08NE3	✓	✓	✓	✓
D3-16NE3	✓	✓	✓	✓
DC Output Modules				
D3-04TD1			✓	
D3-08TD1	✓	✓	✓	✓
D3-08TD2	✓	✓	✓	✓
D3-16TD1-1	✓	✓	✓	✓
D3-16TD1-2	✓	✓	✓	✓
D3-16TD2	✓	✓	✓	✓
AC Output Modules				
D3-04TAS	✓	✓	✓	✓
D3-08TA-1	✓	✓	✓	✓
D3-08TA-2	✓	✓	✓	✓
F3-08TAS			✓	
F3-08TAS-1	✓	✓		✓
F3-16TA-1			✓	
F3-16TA-2	✓	✓		✓
D3-16TA-2	✓	✓		✓
Relay Output Modules				
D3-08TR	✓	✓	✓	
F3-08TRS-1			✓	
F3-08TRS-2	✓	✓	✓	
F3-08TRS-5	✓	✓	✓	✓
D3-16TR	✓	✓	✓	
Analog Modules				
D3-04AD	✓	✓	✓	✓
F3-04ADS	✓	✓	✓	
F3-08AD	✓	✓	✓	✓
F3-08TEMP	✓	✓	✓	
F3-08THM-n	✓	✓	✓	✓
F3-16AD	✓	✓	✓	✓
D3-02DA	✓	✓	✓	✓
F3-04DA-1	✓	✓	✓	✓
F3-04DAS	✓	✓	✓	
F3-08AD-1	✓	✓		✓

DL305 Agency Approvals*				
	UL	CUL	CE	Class 1 Div 2
Communications and Networking				
D3-232-DCU	✓	✓	✓	
D3-422-DCU	✓	✓	✓	
D3-DCM	✓	✓		✓
ASCII BASIC Modules				
F3-AB128	✓	✓	✓	✓
F3-AB128-R	✓	✓	✓	
F3-AB128-T	✓	✓	✓	✓
Specialty Modules				
D3-08SIM	✓	✓	✓	
D3-HSC	✓	✓	✓	✓
D3-PWU	✓	✓	✓	
D3-TCSU			✓	
Programming				
D3-HP	✓	✓	✓	
D3-HPP	✓	✓	✓	

DL205 Agency Approvals*				
	UL	CUL	CE	Class 1 Div 2 Zone 2
CPUs				
D2-230	✓	✓	✓	✓
D2-240	✓	✓	✓	✓
D2-250	✓	✓	✓	✓
D2-250-1	✓	✓	✓	✓
D2-260	✓	✓	✓	✓
H2-WPLC3-EN	✓	✓		✓
I/O Bases				
D2-03BDC-1	✓	✓	✓	✓
D2-03BDC1-1	✓	✓	✓	✓
D2-03B-1	✓	✓	✓	✓
D2-03BDC-2	✓	✓	✓	✓
D2-04B-1	✓	✓	✓	✓
D2-04BDC-1	✓	✓	✓	✓
D2-04BDC1-1	✓	✓	✓	✓
D2-04DBC-2	✓	✓	✓	✓
D2-06B-1	✓	✓	✓	✓
D2-06BDC-1	✓	✓	✓	✓
D2-06BDC1-1	✓	✓	✓	✓
D2-06BDC-2	✓	✓	✓	✓
D2-06BDC2-1	✓	✓	✓	✓
D2-09B-1	✓	✓	✓	✓
D2-09BDC-1	✓	✓	✓	✓
D2-09BDC1-1	✓	✓	✓	✓
D2-09BDC-2	✓	✓	✓	✓
D2-09BDC2-1	✓	✓	✓	✓

DL205 Agency Approvals*				
	UL	CUL	CE	Class 1 Div 2 Zone 2
DC Input Modules				
D2-08ND3	✓	✓	✓	✓
D2-16ND3-2	✓	✓	✓	✓
D2-32ND3-2	✓	✓	✓	✓
D2-32ND3	✓	✓	✓	✓
DC Output Modules				
D2-04TD1	✓	✓	✓	✓
D2-08TD1	✓	✓	✓	✓
D2-08TD2	✓	✓	✓	✓
D2-16TD1-1	✓	✓	✓	✓
D2-16TD2-2	✓	✓	✓	✓
F2-16TD1P	✓	✓		✓
F2-16TD2P	✓	✓		✓
D2-32TD1	✓	✓	✓	✓
D2-32TD2	✓	✓	✓	✓
AC Input Modules				
D2-08NA-1	✓	✓	✓	✓
D2-16NA	✓	✓	✓	✓
D2-08NA-2	✓	✓	✓	✓
AC Output Modules				
D2-08TA	✓	✓	✓	✓
D2-12TA	✓	✓	✓	✓
F2-08TA	✓	✓		✓
Relay Output Modules				
D2-04TRS	✓	✓	✓	✓
D2-08TR	✓	✓	✓	✓
D2-08TRS	✓	✓	✓	✓
D2-12TR	✓	✓	✓	✓
F2-08TRS	✓	✓	✓	
F2-08TR	✓	✓	✓	

*For the latest information on agency approvals, check our Web site.
 UL (Underwriters Laboratories, Inc.)
 CUL (Canadian Underwriters Laboratories, Inc.)
 CE (EMC Directive, LV Directive)
 Class 1, Div 2 (Tested by Underwriters Laboratories, Inc., file no. E200031)

Agency Approvals

DL205 Agency Approvals*				
	UL	CUL	CE	Class 1 Div 2 Zone 2
Analog Modules				
F2-04AD-1	✓	✓	✓	✓
F2-04AD-2	✓	✓	✓	✓
F2-02DA-1	✓	✓	✓	✓
F2-02DA-2	✓	✓	✓	✓
F2-02DA-1L	✓	✓	✓	✓
F2-02DL-2L	✓	✓	✓	✓
F2-02DAS-1	✓	✓	✓	✓
F2-02DAS-2				
F2-4AD2DA	✓	✓	✓	✓
F2-8AD4DA-1	✓	✓		✓
F2-8AD4DA-2	✓	✓		✓
F2-08DA-1	✓	✓	✓	✓
F2-08AD-1	✓	✓	✓	✓
F2-08AD-2	✓	✓	✓	✓
F2-08DA-2	✓	✓	✓	✓
F2-04AD-1L	✓	✓	✓	✓
F2-04AD-2L	✓	✓	✓	✓
F2-04RTD	✓	✓	✓	✓
F2-04THM	✓	✓	✓	✓
Remote I/O				
D2-RMSM	✓	✓	✓	✓
D2-RSSS	✓	✓	✓	✓
F2-SDS-1	✓	✓	✓	✓
F2-DEVNETS	✓	✓	✓	✓
D2-CM	✓	✓	✓	✓
D2-EM	✓	✓	✓	✓
H2-ERM	✓	✓	✓	✓
H2-ERM-F	✓	✓		✓
Combination Modules				
D2-08CDR	✓	✓	✓	✓
Communications and Networking				
D2-DCM	✓	✓	✓	✓
H2-ECOM	✓	✓	✓	✓
H2-ECOM100	✓	✓		✓
H2-EBC	✓	✓	✓	✓
H2-EBC100	✓	✓	✓	✓
H2-ECOM-F	✓	✓		✓
H2-EBC-F	✓	✓		✓
H2-SERIO	✓	✓	✓	✓
H2-SERIO-4	✓	✓		✓
F2-DEVNETS-1	✓	✓	✓	✓
H2-PBC	✓	✓	✓	✓

DL205 Agency Approval*				
	UL	CUL	CE	Class 1 Div 2 Zone 2
Specialty Modules				
D2-CTRINT	✓	✓	✓	✓
F2-CP128	✓	✓	✓	✓
F2-08SIM	✓	✓	✓	
H2-CTRIO	✓	✓	✓	✓
Programming				
D2-HPP	✓	✓	✓	✓

Control & Communications Accessories Agency Approvals*				
	UL	CUL	CE	Class 1 Div 2
FA-UNICON	✓	✓	✓	
F2-UNICON	✓	✓		
FA-ISONET	✓	✓		
FA-REC3	✓	✓		
HA-TADP	✓	✓		
HA-FTADP	✓	✓		
FA-24PS-xx	✓	✓		✓
FA-4PWM				
FA-ISOCON	✓	✓		✓
MB-GATEWAY	✓	✓		
USB-485M			✓	

DL105 Agency Approvals*				
	UL	CUL	CE	Class 1 Div 2
Micro PLCs				
F1-130AA	✓	✓		
F1-130AD	✓	✓		
F1-130AR	✓	✓		
F1-130DA	✓	✓		
F1-130DD	✓	✓		
F1-130DR	✓	✓		
F1-130DD-D	✓	✓		
F1-130DR-D	✓	✓		
F1-DVNET-AR	✓	✓		
F1-DVNET-DD	✓	✓		
F1-DVNET-DR	✓	✓		

DL06 Agency Approvals*				
	UL	CUL	CE	Class 1 Div 2 Zone 2
PLCs				
D0-06AA	✓	✓	✓	✓
D0-06AR	✓	✓	✓	✓
D0-06DA	✓	✓	✓	✓
D0-06DD1	✓	✓	✓	✓
D0-06DD2	✓	✓	✓	✓
D0-06DR	✓	✓	✓	✓
D0-06DD1-D	✓	✓	✓	✓
D0-06DD2-D	✓	✓	✓	✓
D0-06DR-D	✓	✓	✓	✓
DL06-Only Module				
D0-06LCD			✓	

DL05 Agency Approvals*				
	UL	CUL	CE	Class 1 Div 2
PLCs				
D0-05AA	✓	✓	✓	
D0-05AD	✓	✓	✓	
D0-05AR	✓	✓	✓	
D0-05DA	✓	✓	✓	
D0-05DD	✓	✓	✓	
D0-05DR	✓	✓	✓	
D0-05DD-D	✓	✓	✓	
D0-05DR-D	✓	✓	✓	
05-Only Option Module				
D0-01MC	✓	✓	✓	

DL05/DL06 Agency Approvals*				
	UL	CUL	CE	Class 1 Div 2
DL05/DL06 Discrete Option Modules ^{Note 1}				
D0-07CDR	✓	✓	✓	✓
D0-08CDD1	✓	✓	✓	✓
D0-08TR	✓	✓	✓	✓
D0-10ND3	✓	✓	✓	✓
D0-10ND3F				
D0-10TD1	✓	✓	✓	✓
D0-10TD2	✓	✓	✓	✓
D0-16ND3	✓	✓	✓	✓
D0-16TD1	✓	✓	✓	✓
D0-16TD2	✓	✓	✓	✓
F0-04TRS				
F0-08NA-1	✓	✓	✓	✓

Note 1: The DL05/06 discrete option modules are generic CE compliant only, not 61131-2 as the modules do not have LED indicators.

*For the latest information on agency approvals, check our Web site.
 UL (Underwriters Laboratories, Inc.)
 CUL (Canadian Underwriters Laboratories, Inc.)
 CE (EMC Directive, IV Directive)
 Class 1, Div 2 (Tested by Underwriters Laboratories, Inc., file no. E200031)

Agency Approvals

DL05/DL06 Agency Approvals*				
	UL	CUL	CE	Class 1 Div 2 Zone 2
DL05/DL06 Analog Option Modules				
FO-04AD-1	✓	✓	✓	✓
FO-2AD2DA-2	✓	✓	✓	✓
FO-4AD2DA-1	✓	✓	✓	✓
FO-4AD2DA-2	✓	✓	✓	✓
FO-08ADH-1	✓	✓		✓
FO-08ADH-2	✓	✓		✓
FO-08DAH-1	✓	✓		✓
FO-08DAH-2	✓	✓		✓
FO-04DAH-1	✓	✓		✓
FO-04DAH-2	✓	✓		✓
FO-04AD-2	✓	✓	✓	✓
FO-04THM	✓	✓	✓	✓
FO-04RTD	✓	✓	✓	✓
DL05/DL06 Communications Modules				
DO-DEVNETS				
HO-ECOM	✓	✓	✓	✓
DO-DCM				
HO-ECOM100	✓	✓	✓	
HO-PSCM	✓	✓	✓	✓
DL05/DL06 Specialty Modules				
HO-CTRIO	✓	✓	✓	✓
FO-CP128	✓	✓		✓
FO-08SIM	✓	✓		✓

CLICK PLC Agency Approvals*				
	UL	CUL	CE	Class 1 Div 2 Zone 2
CPUs				
CO-00DD1-D	✓	✓	✓	
CO-00DD2-D	✓	✓	✓	
CO-00DR-D	✓	✓	✓	
CO-00AR-D	✓	✓	✓	
CO-01DD1-D	✓	✓	✓	
CO-01DD2-D	✓	✓	✓	
CO-01DR-D	✓	✓	✓	
CO-01AR-D	✓	✓	✓	
CO-02DD1-D	✓	✓	✓	
CO-02DD2-D	✓	✓	✓	
CO-02DR-D	✓	✓	✓	
Power Supplies				
CO-00AC	✓	✓	✓	
CO-01AC	✓	✓	✓	
Input Modules				
CO-08ND3	✓	✓	✓	
CO-08ND3-1	✓	✓	✓	
CO-16ND3	✓	✓	✓	
CO-08NE3	✓	✓	✓	
CO-16NE3	✓	✓	✓	
CO-08NA	✓	✓	✓	
Output Modules				
CO-08TD1	✓	✓	✓	
CO-08TD2	✓	✓	✓	
CO-16TD1	✓	✓	✓	
CO-16TD2	✓	✓	✓	
CO-08TA	✓	✓	✓	
CO-04TRS	✓	✓	✓	
CO-08TR	✓	✓	✓	

Operator Panel Agency Approvals*				
	UL	CUL	CE	Class 1 Div 2
DirectLogic				
DV1000	✓	✓	✓	
DirectTouch				
DP-M320, 321	✓	✓	✓	
DP-C320, 321	✓	✓	✓	
Optimate Panels				
Atlas Industrial Monitors	✓	✓	✓	✓
C-more Panels				
EA7-S6M-R	✓	✓	✓	
EA7-S6M	✓	✓	✓	
EA7-S6C-R	✓	✓	✓	
EA7-S6C	✓	✓	✓	
EA7-T6C	✓	✓	✓	
EA7-T6CL	✓	✓	✓	
EA7-T6CL-R	✓	✓	✓	
EA7-T8C	✓	✓	✓	
EA7-T10C	✓	✓	✓	
EA7-T12C	✓	✓	✓	
EA7-T15C	✓	✓	✓	
C-more Micro Panels				
EA1-S3ML-N	✓	✓	✓	
EA1-S3ML	✓	✓	✓	
EA1-S3MLW	✓	✓	✓	
EA1-S3MLW-N	✓	✓	✓	
EA-MG-BZ1	✓	✓	✓	
EA-MG-BZ2	✓	✓	✓	
EA1-T4CL	✓	✓	✓	
EA1-S6ML	✓	✓	✓	
EA1-S6MLW	✓	✓	✓	
EA1-T6CL	✓	✓	✓	
EA-MG6-BZ2	✓	✓	✓	
EA-MG6-BZ2P	✓	✓	✓	
EA-MG-P1	✓	✓	✓	
EA-MG-SP1	✓	✓	✓	

*For the latest information on agency approvals, check our Web site.
 UL (Underwriters Laboratories, Inc.)
 CUL (Canadian Underwriters Laboratories, Inc.)
 CE (EMC Directive, LV Directive)
 Class 1, Div 2 (Tested by Underwriters Laboratories, Inc., file no. E200031)

Agency Approvals

Terminator I/O Agency Approvals*				
	UL	cUL	CE	Class 1 Div 2 Zone 2
Power Supplies and Bases				
T1K-01AC	✓	✓	✓	✓
T1K-01DC	✓	✓	✓	✓
T1K-08B	✓	✓	✓	✓
T1K-16B	✓	✓	✓	✓
T1K-08B-1	✓	✓	✓	✓
T1K-16B-1	✓	✓	✓	✓
Discrete Input Modules				
T1K-08ND3	✓	✓	✓	✓
T1K-16ND3	✓	✓	✓	✓
T1K-08NA-1	✓	✓	✓	✓
T1K-16NA-1	✓	✓	✓	✓
Discrete Output Modules				
T1H-08TDS	✓	✓		
T1K-08TD1	✓	✓	✓	✓
T1K-16TD1	✓	✓	✓	✓
T1K-16TD2	✓	✓	✓	✓
T1K-16TD2-1	✓	✓	✓	✓
T1K-08TA	✓	✓	✓	✓
T1K-08TAS	✓	✓	✓	✓
T1K-16TA	✓	✓	✓	✓
T1K-16TR	✓	✓	✓	✓
T1K-08TR	✓	✓	✓	✓
T1K-08TRS	✓	✓	✓	✓
T1K-08TD2-1	✓	✓	✓	✓
Analog Modules				
T1F-08AD-1	✓	✓	✓	✓
T1F-08AD-2	✓	✓	✓	✓
T1F-08DA-1	✓	✓	✓	✓
T1F-08DA-2	✓	✓	✓	✓
T1F-16AD-1	✓	✓	✓	✓
T1F-16AD-2	✓	✓	✓	✓
T1F-16DA-1	✓	✓	✓	✓
T1F-16DA-2	✓	✓	✓	✓
T1F-14THM	✓	✓	✓	✓
T1F-16RTD	✓	✓	✓	✓
Combination Analog Modules				
T1F-08AD4DA-1	✓	✓	✓	✓
T1F-08AD4DA-2	✓	✓	✓	✓
Network Interface Modules				
T1H-EBC	✓	✓	✓	✓
T1H-EBC100	✓	✓		✓
T1H-PBC	✓	✓	✓	✓
T1K-DEVNETS	✓	✓	✓	✓
T1K-MODBUS	✓	✓	✓	✓
T1K-RSSS	✓	✓	✓	✓
Specialty Modules				
T1H-CTRIO	✓	✓		✓

Motors and Drives Agency Approvals*				
	UL	cUL	CE	Class 1 Div 2 Zone 2
SureServo				
Drives (SVA-xxxx)	✓	✓	✓	
Motors (SVL-xxxx and SVM-xxxx)	✓	✓	✓	
GS and DuraPulse				
Drives	✓	✓	✓**	
GS-EDRV				
GS-EDRV100	✓	✓		
Line Reactors				
GS series	✓	✓	✓	
LR series	✓	✓	✓	
Steppers				
Stepper Drive			✓	
Stepper Power Supply	✓	✓	✓	
Stepper Motor			✓	
Hitachi				
L100 series	✓		✓	
SJ100 series	✓		✓	
IronHorse Motors				
Cast Iron (T, TC-Frames)			✓	
DC			✓	
Rolled Steel			✓	
Marathon Motors	✓			

** GS2-5xxx series 575V AC drives are not CE compliant.

AutomationDirect Agency Approvals*				
	UL	cUL/CSA	CE	Class 1 Div 2
All contactors	✓	✓	✓	
All drives	✓	✓	✓	
All limit switches	✓	✓	✓	
All modems/ethernet switches	✓	✓	✓	✓
All photo sensors	✓	✓	✓	
LED photo sensor cables	✓	✓		
All proximity switches**	✓	✓	✓	
All power supplies	✓	✓**	✓	✓**
All relays	✓	✓***	✓***	✓***
All timers/counters (incl. timers/counters/tachs)	✓	✓	✓	

*For the latest information on agency approvals, check our Web site.

** PSS series are not CE approved. Only these power supplies are UL Class 1, Div 2 approved: PS24-075D, PS24-150D, PS24-300D.

*** All relays are CSA listed except HSSR8 series. All relays are CE marked except H750 series. Only HSSR8 series, H750 and H782 series relays are rated for UL Class 1, Div 2 environments. All relays are also RoHS marked.

AcuAMP Agency Approvals*				
	UL	CSA	CE	Class 1 Div 2
Current Sensors, Switches, Transducers	✓		✓	

BM Agency Approvals*				
	UL	CSA	CE	Class 1 Div 2
All cable ties**	✓			

*For the latest information on agency approvals, check our Web site.
** except for the following parts, which are not UL approved: BM-N8912, BM-N1012, BM-R1576, BM-R2076, BM-R3076. All BM-Txxxx, All cable mounts and hand tools.

Bryant Wiring Devices				
	UL	CSA	CE	Class 1 Div 2
Plugs, Connectors, Receptacles, Cover Plates	✓	✓		
Manual Motor Controllers	✓	✓		

Comepi Safety Devices				
	UL	CSA	CE	RoHS
Safety Limit Switches	✓	✓	✓	✓

Contrinex Safety Devices				
	UL	CSA	CE	TUV
Safety Light Curtains	✓		✓	✓

Cutler-Hammer Agency Approvals*				
	UL	CSA	CE	Class 1 Div 2
All contactors	✓	✓	✓	
All pushbuttons	✓	✓	✓	

Dold Safety Relays				
	cUL	CSA	CE	Class 1 Div 2
All models	✓		✓	

*For the latest information on agency approvals, check our Web site.
UL (Underwriters Laboratories, Inc.)
CUL (Canadian Underwriters Laboratories, Inc.)
CE (EMC Directive, LV Directive)
Class 1, Div 2 (Tested by Underwriters Laboratories, Inc., file no. E200031)

Agency Approvals

Eaton*					
	UL	cUL	CSA	CE	RoHS
WMZS	✓		✓	✓	✓
WMZT	✓		✓	✓	✓

Edison*					
	UL	cUL	CSA	CE	RoHS
ABC, AGC, ECNR, ECSR, EDCC, GMA, GMC, HCLR, HCTR, JDL, LENRK, LESRK, MCL, MDA, MDL, MEN, MEQ, S500, S506 Series Fuses	✓		✓		
JHL Series Fuses	✓		✓		✓
MOL, TJN, TJS Series Fuses	✓		✓	✓	
CH Series Fuse Holders		✓		✓	
HPB Series Power Distribution Blocks	✓			✓	

FC Signal Conditioners *				
	UL, cUL	CE	RoHS	Class 1 Div 2
FC-11, FC-33, FC-R1, FC-R1	✓	✓		✓

Fuji Agency Approvals*				
	UL	cUL	CE	Class 1 Div 2
Molded Case CBs	✓	✓	✓	
Motor Controls	✓	✓	✓	
Man'l Motor Starters	✓	✓	✓	
Pushbuttons	✓			
Timers, Card Relays	✓	✓	✓	

Gladiator Fusible Switches				
	UL	cUL	CE	Class 1 Div 2
CFS series	✓	✓	✓	

Hammond Transformers*				
	UL	cUL	CE	Class 1 Div 2
Control	✓	✓	✓	
Encapsulated	✓	✓	✓	

Jefferson Electric Buck-Boost Transformers*					
	UL	cUL	CSA	CE	RoHS
All models	✓	✓	✓		✓

Nitra FRL's				
	UL	cUL	CE	Class 1 Div 2
All models			✓	

Nitra Cylinder Switches*				
	UL	cUL	CE	Class 1 Div 2
All models	✓	✓	✓	

ProSense Pressure/Temp Transmitters				
	UL	cUL	CE	Class 1 Div 2
All models	✓	✓	✓	

SOLO Temperature Controllers*				
	UL	cUL	CE	Class 1 Div 2
All models	✓	✓	✓	

Stellar Soft Starters*				
	UL	cUL	CE	Class 1 Div 2
SR22 series, including accessory fans	✓		✓	
SR33 series	✓		✓	
SR44 series	✓		✓	

Stratus Air Conditioners*				
	UL	cUL	CE	Class 1 Div 2
All models	✓			

Stride Ethernet Switches*				
	UL	cUL	CE	Class 1 Div 2
All models	✓	✓	✓	✓

Universal Signal Conditioners *				
	UL, cUL	CE	RoHS	Class 1 Div 2
884114, 884116	✓	✓	✓	

Werma Signaltechnik *				
	UL, cUL	CE	RoHS	Class 1 Div 2
All Stack Lights	✓	✓	✓	

Wire Cord*				
	UL	cUL	CE	Class 1 Div 2
All types	✓	✓	✓	

ZIPLinks*				
	UL	cUL	CE	Class 1 Div 2
FACTS Models	✓	✓	✓	
Non-FACTS Models	✓	✓	✓	

*For the latest information on agency approvals, check our Web site.
 UL (Underwriters Laboratories, Inc.)
 cUL (Canadian Underwriters Laboratories, Inc.)
 CE (EMC Directive, LV Directive)
 Class 1, Div 2 (Tested by Underwriters Laboratories, Inc., file no. E200031)

Product Compatibility

Compatible products

Here's a brief list to help you identify compatible products.

DirectLogic	Compatible
DL05	None
DL06	None
DL105	None
DL205	None
DL305	GE Series 1 TI 305 Simatic TI 305
DL405	TI 405 Simatic TI405

Compatible communication drivers

DirectLogic	Compatible
DirectNet	CCM (GE) Hostlink (TI/Siemens)

A driver created for a compatible PLC will probably work with our PLCs. However, some of our newer CPUs have more memory than similar products offered by previous vendors. If using one of their drivers, make sure you ask if their driver performs memory range checking. If it does, then you may not be able to access all of the memory locations.

Communication protocols

Some vendors may specify a communication protocol instead of a PLC family name. Use the chart shown on this page to help you identify the protocol and PLC port usage.

	CPU/ device	Port	Protocol	
DL05 DL06	D0-05	Port 1	K-sequence, DirectNET and Modbus RTU slave	
		Port 2	K-sequence slave, DirectNET and Modbus RTU master/slave	
	D0-06	Port 1	K-sequence, DirectNET and Modbus RTU slave	
		Port 2	K-sequence slave, DirectNET and Modbus RTU master/slave	
	D0-DCM	Port 1	K-sequence, DirectNET and Modbus RTU slave	
		Port 2	K-sequence slave, DirectNET and Modbus RTU master/slave	
DL105	F1-130	Only one	K-sequence slave	
DL205	D2-230	Only one	K-sequence slave	
		D2-240	Top port	K-sequence slave
		Bottom port	K-sequence and DirectNET slaves	
	D2-250-1	Top port	K-sequence, DirectNET and Modbus RTU slaves	
		Bottom port	K-sequence slave, DirectNET and Modbus RTU master/slave	
	D2-260	Top port	K-sequence, DirectNET and Modbus RTU slaves	
		Bottom port	K-sequence slave, DirectNET and Modbus RTU master/slave	
	D2-DCM (module used with D2-240/250-1/260)	Only one	K-sequence slave DirectNET master/slave Modbus RTU slave	
	DL305	D3-330	Requires DCU	DirectNET slave
		D3-330P	Requires DCU	DirectNET slave
D3-340		Top port	DirectNET slave	
		Bottom port	DirectNET master/slave Modbus RTU slave	
D3-350		Top port	K-sequence and DirectNET slave	
		Bottom port	K-sequence slave, DirectNET and Modbus RTU master/slave	
D3-DCM (module used with D3-350 CPU)		Only one	K-sequence slave DirectNET master/slave Modbus RTU slave	
DL405		D4-430	Top port (15-pin)	K-sequence slave
	Bottom port (25-pin)		K-sequence and DirectNET slave	
	D4-440	Top port (15-pin)	K-sequence slave	
		Bottom port (25-pin)	K-sequence and DirectNET slave	
	D4-450	Phone jack	K-sequence and DirectNET slave	
		Top port (15-pin)	K-sequence slave	
		Bottom port (25-pin)	K-sequence slave, DirectNET and Modbus RTU master/slave	
	D4-DCM (module)	Only one	K-sequence slave DirectNET master/slave Modbus RTU slave	

SI DIRECT: System Integrator Program

Do you need local service and support for your AutomationDirect equipment?

Would you like help planning and installing an AutomationDirect project?

Check out SI DIRECT,
The AutomationDirect
System Integrator Program!

To extend our award-winning customer service and support into the field, we've formed a team of qualified system integrators who are ready to help. Whether you need an integrator to design, build, and install your next automation project, or someone to troubleshoot your existing machinery, simply contact one of our authorized system integrators. You can be assured you're dealing with a company that has the expertise and experience to tackle your automation challenges.

View our list of integrators at www.automationdirect.com/si or use the link on our homepage to access the System Integrator section. There, search for integrators by geographical region, product expertise or industry experience.

Not sure which integrator is right for your particular project? We'll be happy to assist you; just email us at systemintegration@automationdirect.com.

Attention Integrators!

Are you a reputable system integrator with a proven history of installing and servicing AutomationDirect components? If so, think about joining our team of integrators! At www.automationdirect.com/si, you can take a look at SI DIRECT, our authorized System Integrator Program. There you can view the benefits and requirements associated with becoming an authorized SI, and submit an application.

If your company has expertise with our wide array of industrial control components, and wants to enter into a mutually beneficial relationship with AutomationDirect, we want to hear from you!

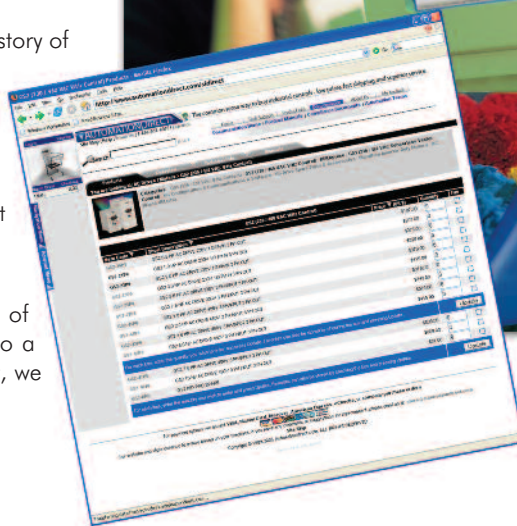

Training Courses and Information

Training by seasoned veteran Doug Bell of InterConnecting Automation, Inc.

Do you need training courses for PLCs or drives, taught by someone who has used many of our products to solve difficult, real-world application problems? Would you be even more interested if the training was held in a city near you? We thought so!

For the most current schedule, visit the InterConnectingAutomation website:

www.interconnectingautomation.com

If your city isn't listed there, or if you need an on-site class, custom class etc., then please call the folks at InterConnecting Automation. They can usually create a class to suit a wide variety of special requirements.

Mr. Doug Bell of InterConnecting Automation, Inc., has been using both our products and competitive products for over 25 years. He has years of design and consulting experience, has been the focus of PLC magazine articles, and now offers training classes taught at various locations around the country.

Mr. Bell started his career as an Electronics Technician on the factory floor at Crown Cork & Seal, one of the world's premier suppliers of cans and closure systems. So, he can relate to the day-to-day problems associated with using and troubleshooting PLC systems. After his stint at Crown, he established a very successful firm that designs and implements control applications, including programming and startup. Here's a brief list of Mr. Bell's qualifications and applications experience:

- Over 25 years of experience in PLC and control system design, for more than 45 facilities worldwide, including sites in the U.S., France, Germany, England, and Mexico
- Managed various automation projects, including specification, procurement, programming, site startup and maintenance
- Applications experience, including electronic feeder controls, HVAC controls, automated test stations, coating systems, printing lines, motion control systems, high-speed applications, communication systems, device-level network applications, PC-based control solutions, HMI systems, etc.
- Experience in training both factory technicians and operations personnel

Note: *PID class may be taught by guest instructors chosen by Mr. Bell.*

AUTOMATIONDIRECT does not set prices or take reservations for these classes. For additional information, course prices, schedules, reservations, contact:

InterConnectingAutomation
12154 North Ridge Trail
Hales Corners, WI 53130

Phone: 414-425-8348

Fax: 414-425-8363

E-mail:
info@interconnectingautomation.com

Website:
www.interconnectingautomation.com

Introductory PLC course contents

You'll use custom-built training panels that contain our D4-450 CPU, a variety of I/O modules, operator panels, and **DirectSOFT**.

- PLC family overview for all **DirectLOGIC** products
- Basic PLC theory of operation including CPU, bases, discrete I/O, analog I/O, and communications
- System configuration techniques
- Simple RLL programming including timers, counters, drums, basic math, and more.
- Advanced programming including number conversions, subroutines, RLL Plus, PID theory, etc.

Advanced PLC contents

Using training panels that contain our D4-450 CPU, a variety of I/O modules, operator panels, and **DirectSOFT**, you will:

- Create programs based on specs given to you in class
- Learn table and pointer commands
- Wire, program and use Terminator and 205 remote I/O
- Writing and structuring programs using Stage
- Debug, diagnose and program PLC over cell phone

Networking

- Serial RS-232 and RS-422
- Ethernet
 - MAC-IP-PLC-Addressing
- Networking with multiple PLCs
- Control motor speed from a master PLC to a slave w/motor/encoder setup
- Learn to use Read and Write commands and the wiring of a network

PID course contents

You'll use custom-built training panels to:

- Learn PID short cuts and tools
- Learn to setup, tune, troubleshoot and debug PID loops.
- Adjust the gain, reset, rate, and many other PID parameters, to see how they affect the loop



Training Videos and Online Training

INTERCONNECTING AUTOMATION

“Introduction to PLC Logic and Principles” Training Video Set

Mr. Doug Bell of InterConnecting Automation, Inc., offers a basic PLC video training package.

The kit includes the following:

- Two video tapes showing examples of programming with **DirectSOFT**. You can get “Hands-On” experience by following along with the instructor who is using the same hardware. (**DirectSOFT** V2.4a, or later, can be used with this course.)
- Pre-wired PLC trainer based on the AUTOMATIONDIRECT D0-05AR PLC, with push-buttons, lights, selector switches and a programming cable ready to plug into your computer
- A DL05 Users Manual, which is referred to throughout the video and is great for future reference

Benefits of this video course:

- Work in the privacy of your own home/office
- No need to travel anywhere — your family won’t have to do without you!
- Learn at your own pace — take a break when you need it
- Refer to the video at any time — you’ll still have the hardware to experiment with

Overview of course content:

- Basics: introduction, basic wiring, logic AND & OR, sensors, relays, reasons for using a PLC, AUTOMATIONDIRECT PLC families
- CPU Internals: scan time, addressing, I/O (Xs and Ys), commands
- I/O: inside the I/O boards, octal addressing, programming methods -- hand-held programmer - **DirectSOFT**
- **DirectSOFT**: getting started, the launch pad, links, offline vs. online programming, maneuvering through & using **DirectSOFT**, creating and editing rungs
- Programming & Debugging: using inputs and outputs, debugging and status mode, PLC commands, troubleshooting

“PLC Analog I/O” Training Video Set

Mr. Doug Bell of InterConnecting Automation, Inc., offers a PLC Analog I/O training video set.

The kit includes the following:

- Two 2-hour analog training videos, firmware upgrade instructional video, a pre-wired analog trainer and DL05 analog I/O module and manual. This unit is a “plug-and-play” add-on to the DL05 PLC Trainer or any existing DL05 PLC.

PLC Pre-wired Analog I/O Trainer:

- Two 0-10 VDC meters
- Two 0-5 VDC potentiometers
- 24 VDC wall-mount power supply
- DL05 analog combo module, plus pre-wired cable from the trainer to the module, ready to plug into your DL05 PLC trainer or any existing DL05 PLC.

Benefits of this video course:

- Work in the privacy of your own home/office
- No need to travel anywhere — your family won’t have to do without you!
- Learn at your own pace — take a break when you need it
- Refer back to the video at any time — you’ll still have the hardware to experiment with.

Overview of course content:

- Analog I/O principles - voltage, current, thermocouples
- PLC analog modules - input, output, thermocouple
- Configuring the analog I/O modules in the PLC
- DL05 PLC analog tutorial includes configuration, wiring, scaling (standard and non-standard) and programming, using the potentiometers and voltmeters on the trainer unit
- Application programming examples, including controlling motor speed with a drive and an analog output card in a PLC

To order the PLC Logic and Principles video or the PLC Analog I/O video, contact InterConnecting Automation directly at: 414-425-8348, or online at www.interconnectingautomation.com



Inexpensive online PLC training now available

Interconnecting Automation offers an inexpensive subscription-based online training program. The online training section is a component of www.interconnectingautomation.com.

Visitors can view the complete list of videos in each “library” as well as watch sample videos; when ready to purchase, the prospective member registers and pays for their selected libraries on a monthly basis. The member receives unlimited access from a maximum of two PCs anytime during the 30 days; videos can be viewed as many times as needed during the subscription period. Most libraries range from \$29.95 - \$39.95 per month.

Libraries currently available include:

- Introduction to PLC Principles (For the novice-non user with limited controls knowledge)
- CLICK series PLC Training (includes Introduction to PLCs library)

Future libraries include Productivity3000 Training (includes Introduction to PLCs library) and C-more HMI training.

Many of these video libraries will also be offered as interactive training courses, with progress tests and certification upon completion.

For more information, to view sample videos or register for a subscription, visit:

www.interconnectingautomation.com

Company Information

Systems Overview

Programmable Controllers

Field I/O

Software

C-more & other HMI

Drives

Soft Starters

Motors & Gearbox

Steppers/ Servos

Motor Controls

Proximity Sensors

Photo Sensors

Limit Switches

Encoders

Current Sensors

Pressure Sensors

Temperature Sensors

Pushbuttons/ Lights

Process

Relays/ Timers

Comm.

Terminal Blocks & Wiring

Power

Circuit Protection

Enclosures

Tools

Pneumatics

Safety

Appendix

Product Index

Part # Index

www.automationdirect.com

More than just a great online store

In addition to our printed catalog, we have an online network of information available 24/7.

FREE videos, FREE software, FREE documentation, FREE support, FREE magazine . . .

. . . well you get the point. :-)

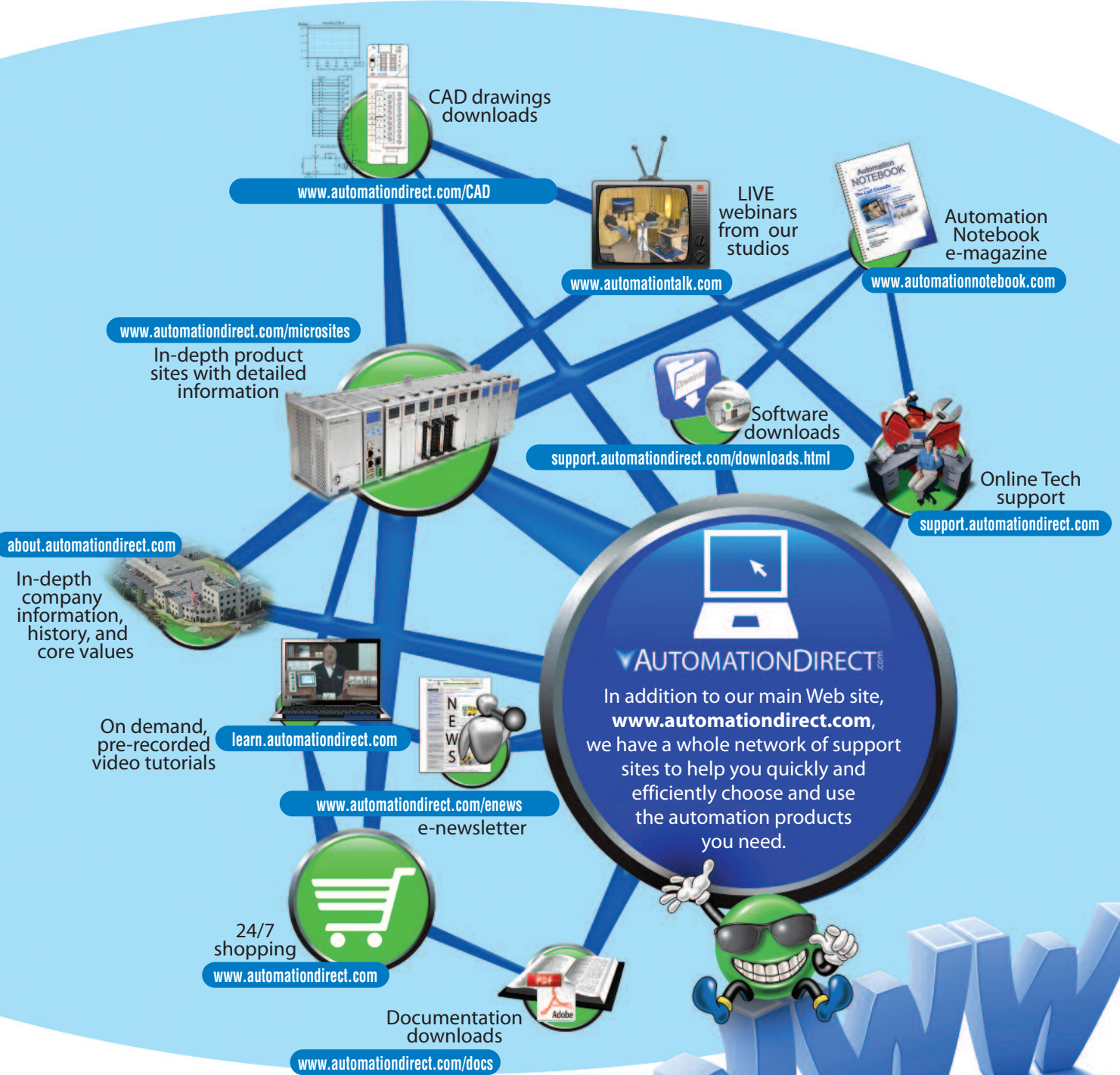

**“Very, very thorough site;
one of the best industrial sites we’ve reviewed”**
IEN magazine March 2009