

LCD DISPLAY PANEL



CHAPTER 10

In This Chapter...

Introduction to the DL06 LCD Display Panel	10-2
Keypad	10-2
Snap-in installation	10-3
Display Priority	10-4
Menu Navigation	10-5
Confirm PLC Type, Firmware Revision Level, Memory Usage, Etc. .	10-6
Examining Option Slot Contents	10-8
Monitoring and Changing Data Values	10-10
Bit Monitor	10-13
Changing Date and Time	10-14
Setting Password and Locking	10-17
Reviewing Error History	10-20
Toggle Light and Beeper, Test Keys	10-21
PLC Memory Information for the Display	10-22
Changing the Default Screen	10-25
DL06 LCD Display Panel Instruction (LCD)	10-26

Introduction to the DL06 LCD Display Panel

The DL06 LCD Display Panel is a 16 character, two row display that mounts directly on the face of the DL06 PLC. The LCD is backlit for easy readability in most lighting situations. There are multiple ways of interacting with the LCD Display Panel:

- Built-in keypad
- LCD ladder instruction
- Using ladder instructions to write bit status changes to specified memory locations

The seven function keys on the face of the LCD Display Panel give the user access to clock and calendar setup, V-memory data values or I/O status, etc. Individuals with password authorization can:

- Change clock or calendar settings or formats
- Monitor or change V-memory values (including DWord values)
- Force individual bits on or off (up to 16 per screen)
- Review error code history
- Set or change the password
- Turn the back light or buzzer on or off

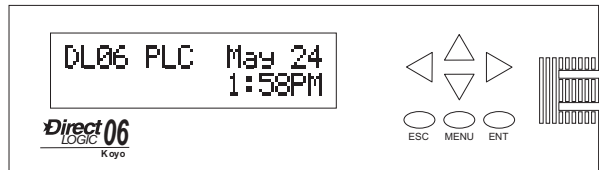

The potential uses for the DL06's LCD display vary widely. An operator can change values for setting up batch processes or machine timing for manufacturing different products. Maintenance personnel can interface in the control cabinet to identify machine problems. LCD messages can be preprogrammed for process events or alarms. The LCD can satisfy these and many other needs.

Keypad

The LCD Display Panel keypad has seven keys you can use to navigate through the menu hierarchy. Each screen displayed has a specific set of active keys associated with it. All other keys (those not associated with the current screen) are inactive.

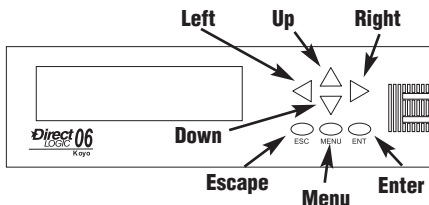

Function Keys		
Name	Label	Function
Up arrow	none	Move to selection above or increase value
Down arrow	none	Move to selection below or decrease value
Left arrow	none	Move to next digit to the left
Right arrow	none	Move to next digit to the right
Escape	ESC	Return to previous screen or next level up in the menu hierarchy
Menu	MENU	Scroll down through main menu or sub-menu selections
Enter	ENT	Enter the domain of the menu screen selected or save new value

Snap-in installation

The LCD Display Panel installs easily into any model DL06 PLC.

Remove the plastic cover (located between the input and output terminals). Press the locking tab of the cover to release it from its catch, and slide the cover to the left about 3/8ths inch.

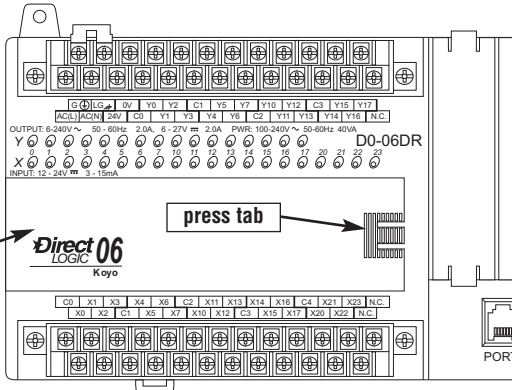

The cover should now lift straight out from the slot on the face of the DL06.

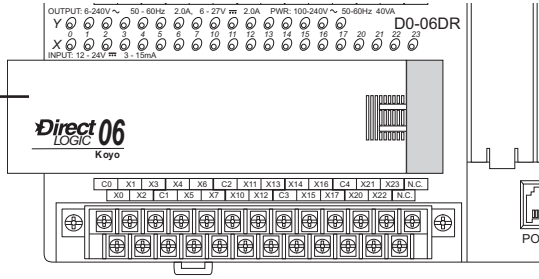

WARNING: Remove power to the PLC before installing or removing the LCD display.

Place the LCD Display Panel over the opening but offset approximately 3/8ths inch to the left. The Display Panel should fit easily into the opening.

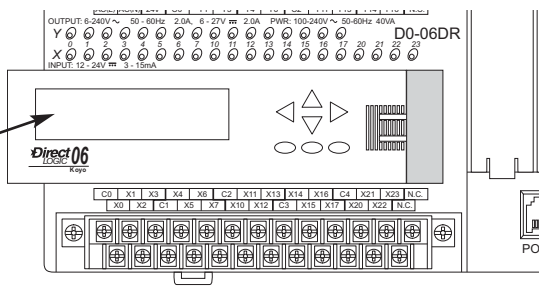

Slide the Display Panel to the right until the left side of the Display Panel is flush with the left side of the PLC. The Display Panel connector will click into place.

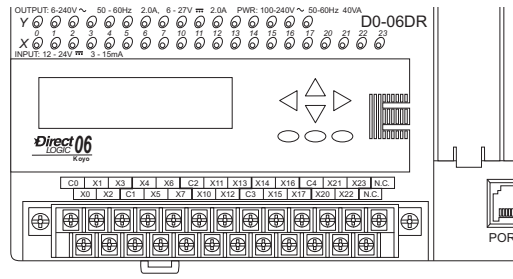
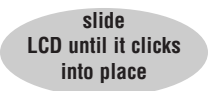

Display Priority

The LCD Display Panel will show one of the following (unless power is removed from the PLC):

- Default screen (user defined or factory default)
- Menu selection
- Message from ladder program
- Error message

The built-in keypad allows you to navigate through these message displays.

On power-up the default message is normally displayed. The default message is set at the factory but can be customized by the user. Loading a custom default message is described later in this chapter.

D	L	0	6		P	L	C			M	a	y		0	8		
										1	3	:	5	7	:	0	1

If a system error occurs, the error message supercedes the default message (or other current display screen), and the appropriate error code is displayed for diagnostic purposes.

D	i	a	g	n	o	s	t	i	c		E	r	r	o	r
E	4	*	*		N	O		P	R	O	G	R	A	M	

Menu Navigation

Beginning at the default screen, each time you press the MENU key the display will scroll to the next menu option. The up arrow and down arrow keys also scroll through the list of menus (in the direction indicated by the arrow), but *you must initially press the MENU key (at the default screen) to activate the up and down arrow keys.*

There are seven built-in menu selections. Some of the menu items have sub-menus. The menus and sub-menus are described in this chapter. Each menu selection requires that you press the ENT key to view or change settings or values within the domain of that main menu selection.

Seven Menu Choices

Pressing and holding the MENU key will cause the display to scroll through the following menu options:

- M1 : PLC information
- M2 : System configuration
- M3 : Monitor
- M4 : Calendar read/write
- M5 : Password read/write
- M6 : Error history read
- M7 : LCD test and set

M	E	N	U	S	C	R	E	E	N						
>	M	1	:	P	L	C		I	N	F	O	.			
>	M	2	:	S	Y	S	T	E	M		C	F	G		
>	M	3	:	M	O	N	I	T	O	R					
>	M	4	:	C	A	L	E	N	D	A	R		R	/	W
>	M	5	:	P	A	S	S	W	O	R			R	/	W
>	M	6	:	E	R	R		H	I	S	T	O	R		
>	M	7	:	L	C	D		T	E	S	T	&	S	E	T



In this section we use illustrations of the LCD Display Panel keypad and display area to show how to navigate through the menu hierarchy. The example below shows the factory default screen as Screen 1 and the main menu entry screen as Screen 2.

The illustration of the keypad between the display screens indicates that pressing the MENU key causes a transition from Screen 1 to Screen 2. This type of representation is used throughout this section. When inside the menu hierarchy, the ESC key returns the display to the previous screen.

Screen 1 - factory default

D	L	0	6	P	L	C			M	a	y	0	8	
							1	4	:	1	2	:	0	1

Press the MENU key to transition from screen 1 to screen 2.

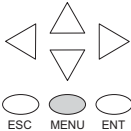

Screen 2

M	E	N	U	S	C	R	E	E	N				
>	M	1	:	P	L	C		I	N	F	O	.	

Confirm PLC Type, Firmware Revision Level, Memory Usage, Etc.

Menu 1, M1:PLC INFO.

From the default screen, press the MENU key one time to arrive at the PLC INFO menu option.

Press ENT to enter this menu selection. The first screen inside the PLC INFO selection is M1:PLC TYPE. This selection displays the model number of the PLC.

Press MENU again to sequence to PLC MODE. The PLC mode is either RUN, STOP (for Stop or Program Mode), TEST-STOP (for Test Stop Mode), or TEST-RUN (for Test Run Mode). You can put the DL06 in the Test Run Mode from the Test Stop Mode.

Default screen

D	L	0	6		P	L	C			M	a	y	0	8	
								1	4	:	1	2	:	0	1

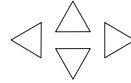

Step 1.1

M	E	N	U		S	C	R	E	E	N				
>	M	1	:	P	L	C		I	N	F	O	.		

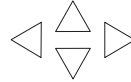

Step 1.2

M	1	:	P	L	C		T	Y	P	E				
							D	0	-	0	6	D	D	1

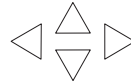

Step 1.3

M	1	:	P	L	C		M	O	D	E					
													R	U	N



NOTE: The menu screen examples shown in this section assume the password/lock feature is not turned on. If the password/lock feature is turned on, the user will be prompted by a message on the Display Panel to enter the password at the appropriate time. Users without password authorization will have access to a limited number of screens.



Press MENU again to sequence to FIRMWARE REV.

Step 1.4

M	1	:	F	I	R	M	W	A	R	E	R	E	V	.
												V	1	. 0 0 0

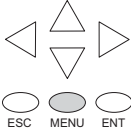

Press MENU again to sequence to LADDER MEMORY USED. The number of words used and the total number available in the PLC are displayed.

Step 1.5

M	1	:	L	A	D	D	E	R	M	E	M	O	R	Y
U	S	E	D				2	1	/		7	6	8	0

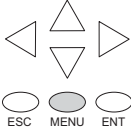

Press MENU again to sequence to LADDER PASSWORD, ACTIVATED OR NOT ACTIVATED. This is the last screen of the PLC INFO menu and is self-explanatory.

Step 1.6

M	1	:	L	A	D	D	E	R	P	A	S	S	W	D
			N	O	T	A	C	T	I	V	A	T	E	D

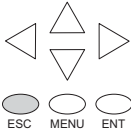

Return to Step 1.1

Press ESC to exit the M1 menu and return to the main menu.

M	E	N	U	S	C	R	E	E	N					
>	M	1	:	P	L	C	I	N	F	O	.			

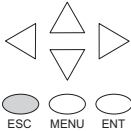

Default screen

Press ESC once more to return to the default screen.

D	L	0	6	P	L	C		M	a	y	0	8		
							1	4	:	2	2	:	1	1

Examining Option Slot Contents

Menu 2, M2:SYSTEM CFG.

From the default screen, press MENU twice to arrive at the M2:SYSTEM CFG. (System Configuration) menu option.

Step 2.1

>	M	1	:	P	L	C		I	N	F	O	.			
>	M	2	:	S	Y	S	T	E	M	C	F	G	.		

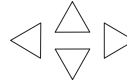

Step 2.2

Press ENT to enter the SYSTEM CFG. menu selection.

M	2	:	O	P	T	I	O	N	S	L	O	T	1		
			D	0	-	D	E	V	N	E	T	S			



NOTE: This is an example only and may not represent the contents of this or any option slot on your system.



Step 2.3

Pressing the MENU key four times will cycle through the four option slots. The model number of the option card in each slot is shown on line 2 or there is an indication that the slot is empty.

M	2	:	O	P	T	I	O	N	S	L	O	T	2		
			E	M	P	T	Y	I	/	O	S	L	O	T	

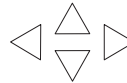

Step 2.4

M	2	:	O	P	T	I	O	N	S	L	O	T	3		
			F	0	-	0	4	A	D	-	1				

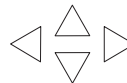

Press the ESC key twice to return to the default screen.

Step 2.5

M	2	:	O	P	T	I	O	N	S	L	O	T	4	
			E	M	P	T	Y	I	/	O	S	L	O	T

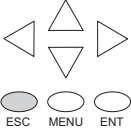

Return to Step 2.1

>	M	1	:	P	L	C		I	N	F	O	.		
>	M	2	:	S	Y	S	T	E	M		C	F	G	.

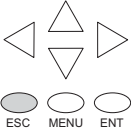

Return to default screen

D	L	0	6		P	L	C			M	a	y		0	8
								1	4	:	5	7	:	2	1

Monitoring and Changing Data Values

Menu 3, M3:MONITOR

From the default screen, press MENU three times to arrive at the M3:MONITOR menu option.

The M3:MONITOR sub-menu contains the data monitor and the bit monitor. The data monitor allows you to examine the contents of memory registers or pointers to determine their contents. The default format is BCD/HEX, but the format can be changed to decimal by setting bit 8 of V7742. Please refer to the DL06 Memory Map for ranges.

Data Monitor

Data type = V for V-memory or P for pointer. Press MENU to change data type, or press ENT to designate the register whose data you want to view or change.

V-memory values

Use the right or left arrow key to move the cursor to the digit you want to change. Use the up or down arrow key to change the digit. The V-memory address is expressed as an octal number so you will not see 8's or 9's.

This screen allows you to view two adjacent V-memory locations in BCD format. The lower word is to the right. Pressing ENT makes it possible to change the value in the **lower word**. At this level of the menu hierarchy, you can also use the up and down arrow keys to scroll to other memory locations.

Step 3.1

>	M 2	:	S	Y	S	T	E	M	C	F	G	.		
>	M 3	:	M	O	N	I	T	O	R					

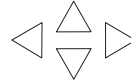

Step 3.2

M 3	:	>	D	A	T	A	M	O	N	I	T	O	R	
		>	B	I	T		M	O	N	I	T	O	R	

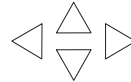

Step 3.3

M 3	:	D	A	T	A	T	Y	P	E				V
A	D	D	R	E	S	S			0	0	0	0	0

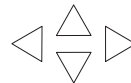

Step 3.4

M 3	:	D	A	T	A	T	Y	P	E				V
A	D	D	R	E	S	S			0	0	0	0	0

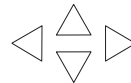

Step 3.5

M 3	:	V				1	V						0
V	A	L			0	0	0	0			0	0	0



The data values on this screen will be four digits in length for BCD/HEX unless bit 8 of V7742 is set. Bit 8 of V7742 changes the data format to decimal (five digits).

Use the right or left arrow key to move the cursor to the digit you want to change. Use the up or down arrow key to move to another digit. The V-memory value is expressed as a BCD number so you will see values (in the range: 0 - F) available for each digit. The data format can be changed to decimal by setting bit 8 of V7742.

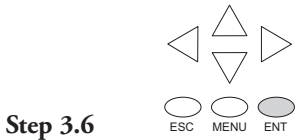

Step 3.6

M	3	:	D	A	T	A			V							0
			C	H	G	=		0	0	0	0			0	0	0



Step 3.7

M	3	:	D	A	T	A			V							0
			C	H	G	=		A	F	0	6			0	0	0



Step 3.8

M	3	:	V						1		V					0
			V	A	L			0	0	0	0			A	F	0

10



Returns to Step 1.1

M	3	:	D	A	T	A			T	Y	P	E				V
			A	D	D	R	E	S					0	0	0	0

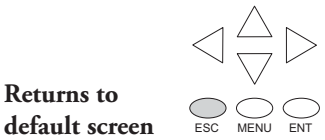

Returns to default screen

Push the ESC key five (5) times to return to the default screen.

D	L	0	6		P	L	C		M	a	y	0	8
								1	5	:	0	2	:
												1	3

Pointer values

Press ESC twice to return to the Step 3.3 screen with the cursor on the V, as shown. Use the up or down arrow key to change the V to P. Now, the pointer information is displayed.

Use the up or down arrow keys to change the value of the current digit. Use the left or right arrow keys to move from one digit to the next.

Return to Step 3.3

M	3	:	D	A	T	A	T	T	E			V	
A	D	D	R	E	S	S				0	0	0	0

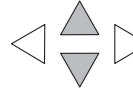

Step 3.4a



M	3	:	D	A	T	A	T	T	E			P	
A	D	D	R	E	S	S				0	0	0	0

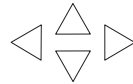

Step 3.5a



M	3	:	D	A	T	A	T	T	E			P	
A	D	D	R	E	S	S				0	0	0	0

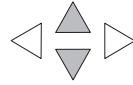

Step 3.6a



M	3	:	D	A	T	A	T	T	E			P	
A	D	D	R	E	S	S				1	0	0	0

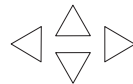

Step 3.7a



M	3	:	D	A	T	A				P	1	0	0	0	0
			(V	0	0	0	0)		2	0	0	0	0

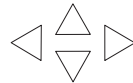

Return to Step 3.3



M	3	:	>	D	A	T	A			M	O	N	I	T	O	R
			>	B	I	T				M	O	N	I	T	O	R

At Step 3.7a, the up and down arrow keys can be used to cycle through data words. Each time you press the up or down arrow key, the address increments or decrements by one 16-bit word (addresses are expressed in octal).

To change from the data monitor to the bit monitor, press ESC three times to return to Step 3.2 (five times to return to the default screen).

Bit Monitor

Bit status

From Step 3.3, press the up or down arrow key, then the ENT key. You will see one of eleven bit data types displayed. The data type that appears on the display is the last data type accessed. The address shown is also the last address accessed for that particular data type.

Press ENT to change the address.

Use the arrow keys to change the address as necessary.

Press ENT to view the selected bits.

Use the left and right arrow keys to select a bit whose status you want to change. Press ENT once to see the change status screen. Press ENT again to change the status from OFF to ON or ON to OFF.

Return to Step 3.3

M	3	:	D	A	T	A	T	T	E				P
A	D	D	R	E	S	S				0	0	0	0

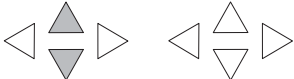

Return to Step 3.3



M	3	:	B	I	T			T	T	E			V
A	D	D	R	E	S	S				0	0	0	0

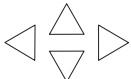

M	3	:	B	I	T			T	T	E			C
A	D	D	R	E	S	S				0	0	0	0

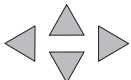

M	3	:	B	I	T			T	T	E			V
A	D	D	R	E	S	S				0	2	5	0

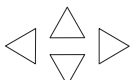

M	3	:	B	I	T	-	0	0		V	2	5	0
0	0	0	0	0	0	0	0	0	0	0	0	0	0

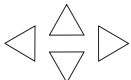

M	3	:	B	I	T	-	0	2		V	2	5	0
C	H	G	=	O	N				S	T	A	T	: O

Changing Date and Time

Menu 4, M4 : CALENDAR R/W

From the default screen, press the MENU key four times to arrive at Step 4.1.

Step 4.1

>	M 3 :	D A T A	T Y P E		
>	M 4 :	C A L E N D A R	R / W		

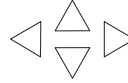

Step 4.2



M 4 :	D A T E	0 5	-	0 8	-	0 2
	T I M E	0 1	:	2 1	:	2 8

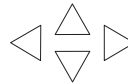

Step 4.3



M 4 :	>	C H A N G E	D A T E		
	>	C H A N G E	T I M E		

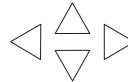

Step 4.4



M 4 :	D A T E	M M	-	D D	-	Y Y
	C H G =	0 5	-	0 8	-	0 2

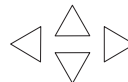

Step 4.5



M 4 :	D A T E	M M	-	D D	-	Y Y
	S E T ?	0 5	-	0 8	-	0 2

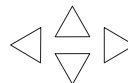

At Step 4.4, use the up and down arrows to change the value for month, day, or year. Use the left and right arrow keys to move between the different digits in the date. After making the necessary changes using the arrow keys, press the ENT key to register the changes.

You will be asked if you want to set the date to the chosen value. Press ENT again if the date is correct. You will automatically return to Step 4.2, and the new date will be displayed.

Returns to
Step 4.2

In order to change the time or date/time format, press ENT again at Step 4.2.

M	4	:	D	A	T	E	0	5	-	0	8	-	0	2
			T	I	M	E	0	1	:	2	1		P	M

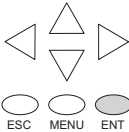

Use the up or down arrow keys or the MENU key to scroll through the sub-menu choices. At this point in our example, we will change the time setting.

M	4	:	>	C	H	A	N	G	E		D	A	T	E
			>	C	H	A	N	G	E		T	I	M	E

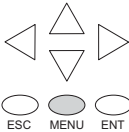

M	4	:	>	C	H	A	N	G	E		T	I	M	E	
			>	C	H	A	N	G	E		F	O	R	M	T

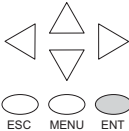

At Step 4.4, use the up and down arrows to change the value for hour, minute, or second. Use the left and right arrow keys to move between the different digits in the time. After making the necessary changes using the arrow keys, press the ENT key to register the changes.

M	4	:	T	I	M	E	H	H	:	M	M	:	S	S
			C	H	G	=	1	3	:	5	3	:	3	2

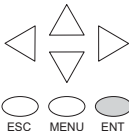

You will be asked if you want to set the date to the chosen value. Press ENT again if the date is correct. You will automatically return to Step 4.2, and the new date will be displayed.

M	4	:	T	I	M	E	H	H	:	M	M	:	S	S
			S	E	T	?	1	3	:	5	3	:	3	2

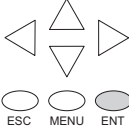

If you want to change the format for the date or time, return to Step 4.2 and press ENT.

Returns to Step 4.2

M	4	:	D	A	T	E		0	5	-	0	8	-	0	2
			T	I	M	E		0	1	:	2	1		P	M



Press ENT, MENU, MENU to arrive at the menu selection for changing the date or time formats. Press ENT again to enter the format changing location.

M	4	:	>	C	H	A	N	G	E		F	O	R	M	T
			>	C	H	A	N	G	E		D	A	T	E	

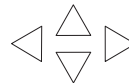

Press ENT again to enter the date format changing location, or press MENU, ENT to change the time format.

M	4	:	>	D	A	T	E		F	O	R	M	A	T	
			>	T	I	M	E		F	O	R	M	A	T	



At Step 4.4, use the up and down arrow keys to scroll through the date formats. The choices are as follows:

- MM-DD-YY (US format)
- DD-MM-YY (European format)
- YY-MM-DD (Asian format)

Press the ENT key to save the format changes.

M	4	:	D	A	T	E		F	O	R	M	A	T		
			C	H	G	=		M	M	-	D	D	-	Y	Y

M	4	:	T	I	M	E		F	O	R	M	A	T		
			C	H	G	=		H	H	:	M	M	:	S	S

If you have chosen to make a time format change, your choices are:

- HH:MM US (12 hour 12:00 - 11:59AM/PM US format)
- HH:MM AS (12 hour 00:00 - 11:59AM/PM Asian format)
- HH:MM:SS (24 hour format)

Press the ENT key to save the format changes. Press ESC until the default screen reappears.

Date and Time Variables and Formats		
__date:us	US format	MM/DD/YY
__date:e	European format	DD/MM/YY
__date:a	Asian format	YY/MM/DD
__time:12	12 hour format	HH:MMAM/PM
__time:24	24 hour format	HH:MM:SS

Setting Password and Locking

Menu 5, M5 : PASSWORD R/W

The LCD Display Panel has its own password protection separate from the *ladder password* protection of the PLC. An LCD Display password can be used to prevent unauthorized changes to clock and calendar setup and V-memory data values. Individuals with password authorization can change clock, calendar, V-memory values, force bits on or off, etc.

The LCD password inhibits unauthorized personnel from modifying the data in the DL06 with the LCD keypad. Even though the LCD password is locked, the user can still modify the data in the DL06 with *DirectSOFT* or the D2-HPP. The LCD Display Panel does not support the multi-level password.

Only menu 5 on the LCD Display can modify the LCD password.



WARNING: The password protection available in *DirectSOFT* or the HPP does not prevent changes from the LCD Display Panel. To prevent changes from the LCD Display Panel, it is necessary to use the LCD password locking feature.



WARNING: The LCD password is apparently entered into the PLC, with no possibility to clear it. If you forget your LCD password, a new PLC must be purchased.

Use the MENU key to navigate to the M5 menu option. Press ENT to arrive at the display shown as Step 5.1.

Assigning a password without locking the display allows access to all features and capabilities of the LCD.

Use the up arrow or down arrow keys to toggle between PASSWD CHG? and LOCK/UNLOCK?. Eight zeroes removes the password. If the password is eight zeroes, the display will not LOCK.

Step 5.1

>	M	4	:	C	A	L	E	N	D	A	R	R	/	W
>	M	5	:	P	A	S	S	W	D	R	/	W		

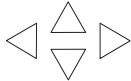

Step 5.2

M	5	:	>	P	A	S	S	W	D	C	H	G	?		
			>	L	O	C	K	/	U	N	L	O	C	K	?

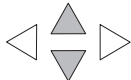

M	5	:	>	P	A	S	S	W	D	C	H	G	?		
			>	L	O	C	K	/	U	N	L	O	C	K	?

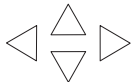

Chapter 10: LCD Display Panel

Use the up arrow or down arrow keys to scroll through number choices, and use the right arrow and left arrow keys to move from one digit position to another.

M	5	:	P	S	W	D	*	*	*	*	*	*	*	*
			C	H	G	=	0	0	0	0	0	0	0	0



NOTE: It is important to record the password where it will not be forgotten and to issue the password only to qualified personnel. Full access to the LCD Display Panel gives access to change data values within the PLC.

M	5	:	P	S	W	D	*	*	*	*	*	*	*	*
			C	H	G	=	2	1	7	0	8	3	0	3

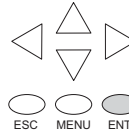

M	5	:	P	S	W	D	*	*	*	*	*	*	*	*
			S	E	T	?	2	1	7	0	8	3	0	3

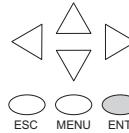

Return to Step 5.2

M	5	:	>	P	A	S	S	W	D	C	H	G	?		
			>	L	O	C	K	/	U	N	L	O	C	K	?

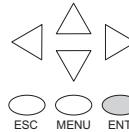

It is not possible to lock the display without assigning a password. It is possible to assign a password without locking the display, but doing so will not protect sensitive data.

Press the ENT key at Step 5.2, and the display is now locked. If you do not wish to lock the display at this point, press ESC.

M	5	:	S	T	A	T	:	U	N	L	O	C	K	E	D
			E	N	T	T	O	L	O	C	K				

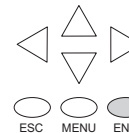

Before assigning a password, you can select LOCK/UNLOCK by pressing ENT at Step 5.2.

**Return to
Step 5.2**

M	5	:	>	P	A	S	S	W	D	C	H	G	?		
			>	L	O	C	K	/	U	N	L	O	C	K	?

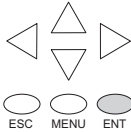

M	5	:	S	T	A	T	:	U	N	L	O	C	K	E	D
			E	N	T	T	O	L	O	C	K				

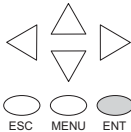

Here, the display prompts you to enter a password.

M	5	:	P	S	W	D	*	*	*	*	*	*	*	*	*
			L	O	C	K	0	0	0	0	0	0	0	0	0

Reviewing Error History

Menu 6, M6 : ERR HISTORY

From the default screen, press the MENU key six times to arrive at Step 6.1.

The Error History screen will display **NO ERROR** if there is no record of errors. If errors have occurred, they can be identified by their Error Code. The Error Code table (see appendix B) will explain the source of the error message. The last 16 messages are displayed. Error messages are displaced when a new error message arrives

Default screen

Step 6.1

>	M	5	:	P	A	S	S	W	O	R	D	R	/	W
>	M	6	:	E	R	R		H	I	S	T	O	R	Y

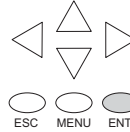

M	6	:	E	R	R	O	R		H	I	S	T	O	R	Y
			N	O		E	R	R	O	R					

D	i	a	g	n	o	s	t	i	c		E	r	r	o	r
E	4	*	*		N	O		P	R	O	G	R	A	M	

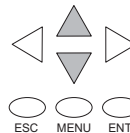

M	6	:	E	r	.		0	5	-	2	2	-	0	2
			E	4	0	1		1	0	:	4	3	A	M

10

To review past error messages use the down arrow key to scroll through the historical record of error messages.

Toggle Light and Beeper, Test Keys

Menu 7, M7 : LCD TEST&SET

This menu selection gives you an opportunity to:

- Test each LCD key to assure that the PLC is receiving its input appropriately
- Turn the beep sound off or on
- Turn the LCD back light off or on

Make a menu selection by pressing the ENT key.

>	M 6 :	ERR	HISTORY						
>	M 7 :	LCD	TEST&SET						

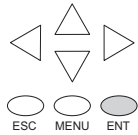

Press ENT to enter the LCD KEY TEST. All keys can be tested for proper function in this menu.

M 7 :	LCD	TEST&SET							
	>	LCD	KEY	TEST					

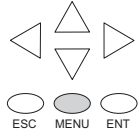

To return to the menu, press the ESC key twice or hold the ESC key down until the menu layer reappears.

Press ENT to enter the Back light test menu.

M 7 :	LCD	TEST&SET							
	>	BACK	LIGHT						

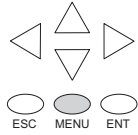

The piezo electric buzzer can be configured to provide pushbutton feedback.

M 7 :	LCD	TEST&SET							
	>	BEEP							

The S, C0 and 0 modifiers alter the presentation of leading zeros and spaces. S removes leading spaces and left justifies the result. C0 replaces leading spaces with leading zeros. 0 is a modification of C0. 0 eliminates any leading zeros in the C0 format version and converts them to spaces.

Reserved memory registers for the LCD Display Panel

Two V-memory registers are reserved for making changes to LCD functions via ladder logic. V7742 allows for bit flags to be set in the ladder program. The bit flags control such things as data formats, the back light, and the beeper. All V7742 bit flags are defined in the table on the next page.

The other reserved register is V7743. This register is used to write a customized default screen message to the LCD. A sample program for this purpose is illustrated later in this chapter.

V-memory address	Contents
V7742	Various LCD flags
	<ul style="list-style-type: none"> • Calendar date and time format • Default operation menu • Data format of data monitor • LCD password status flag • Key press acknowledgement buzzer on/off setting • Back light on/off setting
V7743	Default message location (writing 0 to this address returns the default message to the factory setting)

The following program segment uses the SET and RST coils to turn on and off bit 12 of V7742. When C0 is on, bit 12 is turned on. Bit 12 turns on the beeper in the LCD Display Panel. The C1 contact resets bit 12 to the off state.

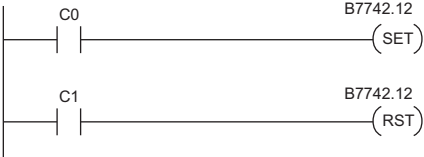

V7742 bit definitions

Bit	15	14	13	12	11	10	9	8	7	6	5	4	3	2	1	0
V7742	*	1	0	0	0	0	0	0	0	0	0	0	0	0	0	0

Bit 1, 0	Date display format (default = 00)	
	00, 11	= Month/Day/Year (US format)
	01	= Day/Month/Year (EU format)
	10	= Year/Month/Day (Asian format)
Bit 3, 2	Time display format (default = 00)	
	00, 11	= HH:MM:SS (24 hour format)
	01	= HH:MM PM/AM (12 hour US format - 12:00 - 11:59)
	10	= HH:MM PM/AM (12 hour Asian format - 00:00 - 11:59)
Bit 6 - 4	Default menu setting (default = 000)	
	000	= Default menu sequence, begins menu sequence with Menu 1
	001	= Begin menu sequence with Menu 1
	010	= Begin menu sequence with Menu 2
	011	= Begin menu sequence with Menu 3
	100	= Begin menu sequence with Menu 4
	101	= Begin menu sequence with Menu 5
	110	= Begin menu sequence with Menu 6
	111	= Begin menu sequence with Menu 7
Bit 8	Data monitor format (default = 0)	
	0	= BCD/HEX format (0000 - FFFF)
	1	= Decimal format (00000 - 65535)
Bit 9	New message overwrite (default = 0)	
	0	= New LCD message clears both lines of previous message
	1	= New LCD message leaves previous message, overwrites specified char. only
Bit 11	LCD password status flag (Read only)	
	0	= Password unlock
	1	= Password lock
Bit 12	Status flag beep on/off control (default = 0)	
	0	= Beep OFF
	1	= Beep ON (LCD beeps continuously during ON status of this flag)
Bit 13	Keypad beep on/off control (default = 0)	
	0	= Beep OFF
	1	= Beep ON (LCD beeps when keys are pressed)
Bit 14	LCD back light setting flag (default = 1)	
	0	= Light OFF
	1	= Light ON
Bit 15	LCD installed status flag (Read only)	
	0	= LCD is not installed
	1	= LCD is installed

10

Changing the Default Screen

At power-up the default screen is displayed. The default screen message is set at the factory but can be customized by the user. One method of customizing the default message uses the VPRINT instruction. The VPRINT instruction is described in Chapter 5.

Factory default message

D	L	0	6	P	L	C			M	a	y	0	8	
							1	4	:	2	0	:	4	9

Example program for setting the default screen message

The following program can be used to set up the default screen message. This program uses the VPRINT instruction to load ASCII text to a designated V-memory location and to embed a pointer to the current date.

The LDA and OUT instructions are used to point to the V-memory location (+1) where the text is located. The memory location V7743 is reserved for the pointer to the default message.



NOTE: The VPRINT instruction adds a one word (2 bytes) non-printing header to the text. For this reason, the LDA instruction points to the V-memory location V10001 rather than V10000.

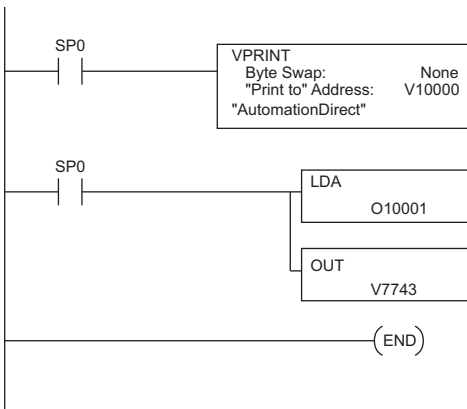

V10000	00h	16h
V10001	u	A
V10002	o	t
V10003	a	m
V10004	i	t
V10005	n	o
V10006	i	D
V10007	e	r
V10010	t	c
V10011		
V10012		
V10013		
V10014		
V10015		
V10016		
V10017		
V10020		

10

After running this program, press MENU, then ESC or cycle power. The new default message should look as indicated. See Menu 4 instructions for changing date and time information.

A	u	t	o	m	a	t	i	o	n	D	i	r	e	c	t



NOTE: It is possible to return to the factory default screen by writing 0 to V7743 and cycling power.

DL06 LCD Display Panel

Instruction (LCD)

From the DirectSOFT project folder, use the Instruction Browser to locate the LCD instruction. When you select the LCD instruction and click OK, the LCD dialog will appear.

The LCD Display Panel instruction is inserted into the ladder program via the set-up dialog box shown to the right. The dialog is used to specify a message to be displayed on line 1 or line 2 LCD Display Panel.

S	l	u	d	g	e		P	i	t		A	l	a	r	m
E	f	f	l	u	e	n	t		O	v	e	r	f	l	o

Source of message

The text of the message can originate from one of two places. It can be input directly from the instruction as a literal text string (see figure A), or it can originate as ASCII text stored in a V-memory location (figure B). In the latter case, it is necessary to specify its beginning V-memory location and length within the dialog box.

Display text strings can include embedded data. Any V-memory value or date and time settings can be embedded in the displayed text.

figure A

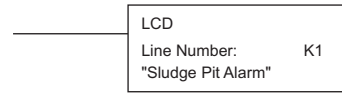
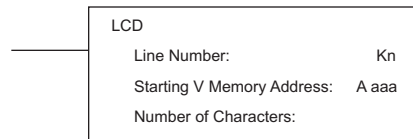

figure B



NOTE: The LCD Display Panel instruction is supported by DirectSOFT, Ver. 5 or later. It is not supported by the D2-HPP handheld programmer.

ASCII Character Codes

ASCII characters can be written directly to V-memory locations and then displayed using the LCD instruction. The table to the right shows the two-digit BCD/HEX code for each character available for display.

Example:
 To display an upper case A, write 41 HEX to the memory location identified by the LCD instruction.

		ASCII Character Codes (BCD/HEX)					
		First Digit					
		2	3	4	5	6	7
Second Digit	0	0	1	2	3	4	5
	1	!	"	#	\$	%	&
	2	"	#	\$	%	&	'
	3	#	\$	%	&	'	(
	4	\$	%	&	'	()
	5	%	&	'	()	*
	6	&	'	()	*	+
	7	'	()	*	+	,
	8	()	*	+	,	-
	9)	*	+	,	-	.
	A	*	+	,	-	.	/
	B	+	,	-	.	/	?
	C	,	-	.	/	?	0
	D	-	.	/	?	0	1
	E	.	/	?	0	1	2
	F	/	?	0	1	2	3

Example program: alarm with embedded date/time stamp

The following program will display the message “Alarm ” and the time on line K1 of the display screen with the date on line K2.

The one-shot, or positive differential (PDd), is used so that the message displays but does not block other messages or menu options. Pressing MENU or ESC will cause the alarm message text to disappear.

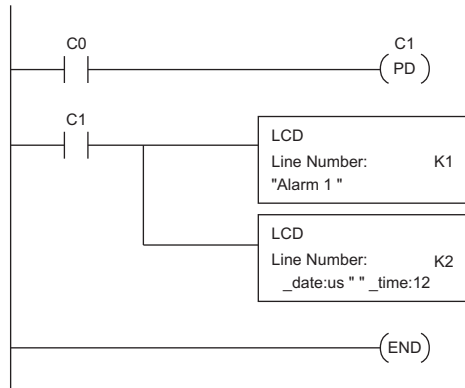

A	l	a	r	m	1												
0	5	/	0	8	/	0	4			5	:	2	3	P	M		

Example program: alarm with embedded V-memory data

In this program example, the alarm notification text is displayed along with the contents of V2500. The suffix "B" is added to the memory location (V2500:B) to cause the data to be displayed as a BCD number.

In the first example, the alarm text is loaded directly via the LCD instruction. In the second example, the alarm text is loaded into V-memory and the LCD instruction is used to point to that text.



NOTE: When using the LCD instruction to display V2000:R, there is a limit of three characters of text because V2000:R uses 13 characters.

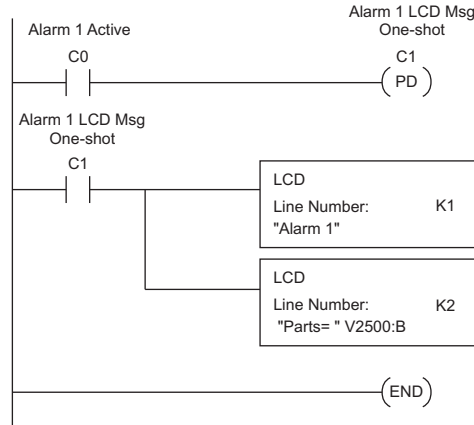

A	l	a	r	m	1														
P	a	r	t	s	=	2	4	3	7										

Example program: alarm text from V-memory with embedded V-memory data

This program example uses the VPRINT instruction to write ASCII text (in the appropriate character sequence) to V10000 and V10010. The LCD instruction is used as a pointer to the V-memory location where the text for each line of the display resides.

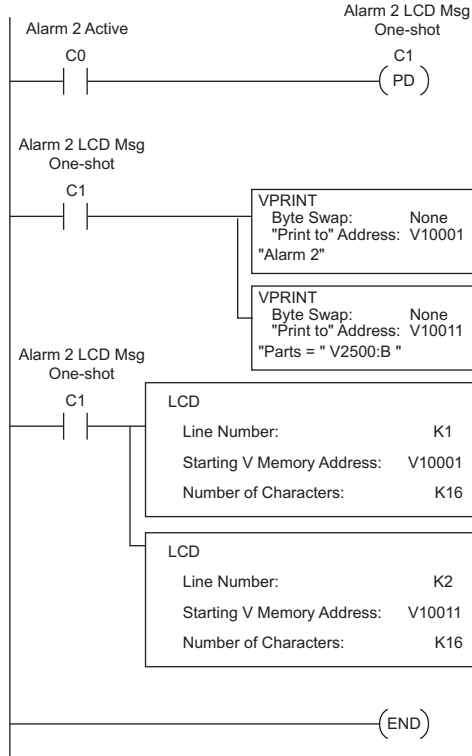

A	l	a	r	m		2													
P	a	r	t	s		=		3		5		8		9					

10