

DL05/06 Option Modules USER MANUAL

Manual Number: D0-OPTIONS-M

~ WARNING ~

Thank you for purchasing automation equipment from **AutomationDirect.com**®, doing business as, **AutomationDirect**. We want your new automation equipment to operate safely. Anyone who installs or uses this equipment should read this publication (and any other relevant publications) before installing or operating the equipment.

To minimize the risk of potential safety problems, you should follow all applicable local and national codes that regulate the installation and operation of your equipment. These codes vary from area to area and usually change with time. It is your responsibility to determine which codes should be followed, and to verify that the equipment, installation, and operation is in compliance with the latest revision of these codes.

At a minimum, you should follow all applicable sections of the National Fire Code, National Electrical Code, and the codes of the National Electrical Manufacturer's Association (NEMA). There may be local regulatory or government offices that can also help determine which codes and standards are necessary for safe installation and operation.

Equipment damage or serious injury to personnel can result from the failure to follow all applicable codes and standards. We do not guarantee the products described in this publication are suitable for your particular application, nor do we assume any responsibility for your product design, installation, or operation.

Our products are not fault-tolerant and are not designed, manufactured or intended for use or resale as on-line control equipment in hazardous environments requiring fail-safe performance, such as in the operation of nuclear facilities, aircraft navigation or communication systems, air traffic control, direct life support machines, or weapons systems, in which the failure of the product could lead directly to death, personal injury, or severe physical or environmental damage ("High Risk Activities"). **AutomationDirect** specifically disclaims any expressed or implied warranty of fitness for High Risk Activities.

For additional warranty and safety information, see the Terms and Conditions section of our catalog. If you have any questions concerning the installation or operation of this equipment, or if you need additional information, please call us at 770-844-4200.

This publication is based on information that was available at the time it was printed. At **AutomationDirect** we constantly strive to improve our products and services, so we reserve the right to make changes to the products and/or publications at any time without notice and without any obligation. This publication may also discuss features that may not be available in certain revisions of the product.

Trademarks

This publication may contain references to products produced and/or offered by other companies. The product and company names may be trademarked and are the sole property of their respective owners. **AutomationDirect** disclaims any proprietary interest in the marks and names of others.

Copyright 2022, **AutomationDirect.com Incorporated**
All Rights Reserved

No part of this manual shall be copied, reproduced, or transmitted in any way without the prior, written consent of **AutomationDirect.com Incorporated**. **AutomationDirect** retains the exclusive rights to all information included in this document.

⚡ ADVERTENCIA ⚡

Gracias por comprar equipo de automatización de **Automationdirect.com**[®]. Deseamos que su nuevo equipo de automatización opere de manera segura. Cualquier persona que instale o use este equipo debe leer esta publicación (y cualquier otra publicación pertinente) antes de instalar u operar el equipo.

Para reducir al mínimo el riesgo debido a problemas de seguridad, debe seguir todos los códigos de seguridad locales o nacionales aplicables que regulan la instalación y operación de su equipo. Estos códigos varían de área en área y usualmente cambian con el tiempo. Es su responsabilidad determinar cuales códigos deben ser seguidos y verificar que el equipo, instalación y operación estén en cumplimiento con la revisión más reciente de estos códigos.

Como mínimo, debe seguir las secciones aplicables del Código Nacional de Incendio, Código Nacional Eléctrico, y los códigos de (NEMA) la Asociación Nacional de Fabricantes Eléctricos de USA. Puede haber oficinas de normas locales o del gobierno que pueden ayudar a determinar cuales códigos y normas son necesarios para una instalación y operación segura.

Si no se siguen todos los códigos y normas aplicables, puede resultar en daños al equipo o lesiones serias a personas. No garantizamos los productos descritos en esta publicación para ser adecuados para su aplicación en particular, ni asumimos ninguna responsabilidad por el diseño de su producto, la instalación u operación.

Nuestros productos no son tolerantes a fallas y no han sido diseñados, fabricados o intencionados para uso o reventa como equipo de control en línea en ambientes peligrosos que requieren una ejecución sin fallas, tales como operación en instalaciones nucleares, sistemas de navegación aérea, o de comunicación, control de tráfico aéreo, máquinas de soporte de vida o sistemas de armamentos en las cuales la falla del producto puede resultar directamente en muerte, heridas personales, o daños físicos o ambientales severos (“Actividades de Alto Riesgo”). **Automationdirect.com** específicamente rechaza cualquier garantía ya sea expresada o implicada para actividades de alto riesgo.

Para información adicional acerca de garantía e información de seguridad, vea la sección de Términos y Condiciones de nuestro catálogo. Si tiene alguna pregunta sobre instalación u operación de este equipo, o si necesita información adicional, por favor llámenos al número 770-844-4200 en Estados Unidos.

Esta publicación está basada en la información disponible al momento de impresión. En **Automationdirect.com** nos esforzamos constantemente para mejorar nuestros productos y servicios, así que nos reservamos el derecho de hacer cambios al producto y/o a las publicaciones en cualquier momento sin notificación y sin ninguna obligación. Esta publicación también puede discutir características que no estén disponibles en ciertas revisiones del producto.

Marcas Registradas

Esta publicación puede contener referencias a productos producidos y/u ofrecidos por otras compañías. Los nombres de las compañías y productos pueden tener marcas registradas y son propiedad única de sus respectivos dueños. **Automationdirect.com**, renuncia cualquier interés propietario en las marcas y nombres de otros.

PROPIEDAD LITERARIA 2022, **AUTOMATIONDIRECT.COM**[®] INCORPORATED
Todos los derechos reservados

No se permite copiar, reproducir, o transmitir de ninguna forma ninguna parte de este manual sin previo consentimiento por escrito de **Automationdirect.com**[®] Incorporated. **Automationdirect.com** retiene los derechos exclusivos a toda la información incluida en este documento. Los usuarios de este equipo pueden copiar este documento solamente para instalar, configurar y mantener el equipo correspondiente. También las instituciones de enseñanza pueden usar este manual para propósitos educativos.

~ AVERTISSEMENT ~

Nous vous remercions d'avoir acheté l'équipement d'automatisation de **AutomationDirect.com**MC, en faisant des affaires comme, **AutomationDirect**. Nous tenons à ce que votre nouvel équipement d'automatisation fonctionne en toute sécurité. Toute personne qui installe ou utilise cet équipement doit lire la présente publication (et toutes les autres publications pertinentes) avant de l'installer ou de l'utiliser.

Afin de réduire au minimum le risque d'éventuels problèmes de sécurité, vous devez respecter tous les codes locaux et nationaux applicables régissant l'installation et le fonctionnement de votre équipement. Ces codes diffèrent d'une région à l'autre et, habituellement, évoluent au fil du temps. Il vous incombe de déterminer les codes à respecter et de vous assurer que l'équipement, l'installation et le fonctionnement sont conformes aux exigences de la version la plus récente de ces codes.

Vous devez, à tout le moins, respecter toutes les sections applicables du Code national de prévention des incendies, du Code national de l'électricité et des codes de la National Electrical Manufacturer's Association (NEMA). Des organismes de réglementation ou des services gouvernementaux locaux peuvent également vous aider à déterminer les codes ainsi que les normes à respecter pour assurer une installation et un fonctionnement sûrs.

L'omission de respecter la totalité des codes et des normes applicables peut entraîner des dommages à l'équipement ou causer de graves blessures au personnel. Nous ne garantissons pas que les produits décrits dans cette publication conviennent à votre application particulière et nous n'assumons aucune responsabilité à l'égard de la conception, de l'installation ou du fonctionnement de votre produit.

Nos produits ne sont pas insensibles aux défaillances et ne sont ni conçus ni fabriqués pour l'utilisation ou la revente en tant qu'équipement de commande en ligne dans des environnements dangereux nécessitant une sécurité absolue, par exemple, l'exploitation d'installations nucléaires, les systèmes de navigation aérienne ou de communication, le contrôle de la circulation aérienne, les équipements de survie ou les systèmes d'armes, pour lesquels la défaillance du produit peut provoquer la mort, des blessures corporelles ou de graves dommages matériels ou environnementaux («activités à risque élevé»). La société **AutomationDirect** nie toute garantie expresse ou implicite d'aptitude à l'emploi en ce qui a trait aux activités à risque élevé.

Pour des renseignements additionnels touchant la garantie et la sécurité, veuillez consulter la section Modalités et conditions de notre documentation. Si vous avez des questions au sujet de l'installation ou du fonctionnement de cet équipement, ou encore si vous avez besoin de renseignements supplémentaires, n'hésitez pas à nous téléphoner au 770-844-4200.

Cette publication s'appuie sur l'information qui était disponible au moment de l'impression. À la société **AutomationDirect**, nous nous efforçons constamment d'améliorer nos produits et services. C'est pourquoi nous nous réservons le droit d'apporter des modifications aux produits ou aux publications en tout temps, sans préavis ni quelque obligation que ce soit. La présente publication peut aussi porter sur des caractéristiques susceptibles de ne pas être offertes dans certaines versions révisées du produit.

Marques de commerce

La présente publication peut contenir des références à des produits fabriqués ou offerts par d'autres entreprises. Les désignations des produits et des entreprises peuvent être des marques de commerce et appartiennent exclusivement à leurs propriétaires respectifs. **AutomationDirect** nie tout intérêt dans les autres marques et désignations.

Copyright 2022, **AutomationDirect.com Incorporated**
Tous droits réservés

Nulle partie de ce manuel ne doit être copiée, reproduite ou transmise de quelque façon que ce soit sans le consentement préalable écrit de la société **AutomationDirect.com Incorporated**. **AutomationDirect** conserve les droits exclusifs à l'égard de tous les renseignements contenus dans le présent document.

DL05/06 OPTION MODULES USER MANUAL



Please include the Manual Number and the Manual Issue, both shown below, when communicating with Technical Support regarding this publication.

Manual Number: D0-OPTIONS-M
 Issue: 7th Edition, Revision F
 Issue Date: 06/22

Publication History		
Issue	Date	Description of Changes
Original	09/01	Original issue
Rev. A	12/01	Made changes to analog specifications
2nd edition	01/02	Added new chapter and minor changes to chapters
3rd edition	05/02	Added wiring guidelines and new discrete module
4th edition	07/02	Added DL06 micro PLC information
4th edition Rev. A	02/03	Minor changes and corrections
5th edition	05/03	Added new chapter
6th edition	08/03	Added one new chapter and reference new discrete module
6th edition Rev. A	01/04	Added one new chapter
6th edition Rev. B	03/04	Added two new discrete modules, moved D0-01MC Memory Cartridge/Real Time Clock module to DL05 user manual
6th edition Rev. C	05/05	Added F0-08SIM module; minor corrections
7th edition	05/07	Added six new chapters for high resolution analog modules
7th edition Rev. A	08/11	Made corrections in ch 3, ch 4 and ch 6.
7th edition Rev. B	03/18	General update, made corrections to Ch 2, Ch 4.
7th edition Rev. C	03/19	Added Special Relay tables to Ch 11.
7th edition Rev. D	07/19	Updated thermocouple graphic Ch15, page 4.
7th edition Rev. E	10/20	Corrected typo Ch4, page 12. Updated formatting.
7th edition Rev. F	06/22	Corrected ladder logic command LD 2000 Ch3 page 16.

TABLE OF CONTENTS



Chapter 1 - Getting Started

Introduction	1-2
The Purpose of this Manual.....	1-2
Supplemental Manuals.....	1-2
Technical Support.....	1-2
Conventions Used	1-2
Key Topics for Each Chapter.....	1-2
Selecting the Proper Module	1-3
DL05.....	1-3
DL06.....	1-3
Module Choices.....	1-3
Module Choices, continued.....	1-4
Installing the Option Modules	1-5
Remove the Slot Cover.....	1-5
Insert the Module.....	1-5
Module LED Indicator	1-6
Power Budgeting	1-6
Power supplied.....	1-6
Power required by base unit.....	1-6
Power required by option cards.....	1-6

Chapter 2 - Discrete I/O Guidelines

Safety Guidelines	2-2
Plan for Safety.....	2-2
Three Levels of Protection.....	2-3
Emergency Stops.....	2-3

Table of Contents

Emergency Power Disconnect	2-4
Orderly System Shutdown.....	2-4
Class 1, Division 2 Approval (Applies ONLY to modules used with a DL06 PLC.).....	2-4
System Wiring Strategies	2-5
PLC Isolation Boundaries	2-5
I/O “Common” Terminal Concepts	2-8
Connecting DC I/O to Solid State Field Devices	2-9
Solid State Input Sensors	2-9
Solid State Output Loads	2-9
Relay Output Guidelines.....	2-11
Prolonging Relay Contact Life	2-11
Surge Suppression For Inductive Loads.....	2-12
Prolonging Relay Contact Life	2-13
DC Input Wiring Methods	2-14
DC Output Wiring Methods.....	2-14
Firmware and Software	2-14
I/O Addressing.....	2-15
Module I/O Points and Addressing for the DL05 and DL06.....	2-15
All Discrete Modules Installed I/O Addressing Example:	2-16
Discrete and Analog Modules Installed I/O Addressing Example:	2-16
Discrete and Analog Modules Installed I/O Addressing Example:	2-16
Discrete I/O General Specifications	2-17
Glossary of Specification Terms	2-18
F0-08SIM 8-Point Simulator Input Module.....	2-19
D0-10ND3 10-Point DC Input Module.....	2-20
D0-10ND3F 10-Point DC Fast Input Module	2-21
D0-16ND3 16-Point DC Input Module.....	2-22
F0-08NA-1 8-Point AC Input Module	2-23
D0-10TD1 10-Point DC Output Module.....	2-24
D0-16TD1 16-Point DC Output Module.....	2-25
D0-10TD2 10-Point DC Output Module.....	2-26
D0-16TD2 16-Point DC Output Module.....	2-27
D0-07CDR 4-Point DC Input, 3-Point Relay Output Module.....	2-28

D0-08TR 8-Point Relay Output Module	2-29
D0-08CDD1 4-Point DC Input, 4-Point DC Output Module.....	2-30
F0-04TRS 4-Point Relay Output Module	2-31

Chapter 3 - F0-04AD-1, 4-Channel Analog Current Input

Module Specifications	3-2
Setting the Module Jumper.....	3-4
Connecting and Disconnecting the Field Wiring	3-4
Wiring Guidelines	3-4
Wiring Diagram	3-5
Current Loop Transmitter Impedance.....	3-5
Module Operation	3-6
Channel Scanning Sequence	3-6
Analog Module Updates.....	3-6
Special V-memory Locations	3-7
Formatting the Module Data.....	3-7
DL05 Data Formatting	3-7
Structure of V7700	3-7
Structure of V7701	3-7
DL06 Data Formatting	3-8
Setup Data Type and Number of Channels	3-8
Storage Pointer Setup	3-8
Using the Pointer in Your Control Program	3-9
DL05 Pointer Method.....	3-9
DL06 Pointer Method.....	3-10
Detecting Input Signal Loss	3-11
Analog Signal Loss.....	3-11
Scale Conversions	3-11
Scaling the Input Data	3-11
The Conversion Program.....	3-12
Analog and Digital Value Conversions	3-12
Special Relays.....	3-13
DL05 Special Relays.....	3-13

DL06 Special Relays.....	3-13
Module Resolution.....	3-15
Analog Data Bits.....	3-15
Resolution Details.....	3-15
Analog Input Ladder Logic Filter	3-16
PID Loops / Filtering:.....	3-16
Smoothing the Input Signal (DL06 only):.....	3-16
Using Binary Data Format	3-16
Using BCD Data Format.....	3-17

Chapter 4 - F0-08ADH-1, 8-Channel Analog Current Input

Module Specifications	4-2
Connecting and Disconnecting the Field Wiring	4-4
Wiring Guidelines.....	4-4
Wiring Diagram	4-5
Current Loop Transmitter Impedance.....	4-5
Module Operation	4-6
Channel Scanning Sequence	4-6
Analog Module Updates.....	4-6
Special V-memory Locations	4-7
Formatting the Analog Module Data.....	4-7
DL05 Data Formatting	4-7
Setup Data Type and Number of Active Channels.....	4-7
Storage Pointer Setup	4-7
DL06 Data Formatting	4-8
Setup Data Type and Number of Active Channels.....	4-8
Storage Pointer Setup	4-8
Using the Pointer in Your Control Program.....	4-9
DL05 Pointer Method Using Conventional Ladder Logic	4-9
DL05 Pointer Method Using the IBox Instruction Available in DirectSOFT5	4-9
DL06 Pointer Method Using Conventional Ladder Logic.....	4-10
DL06 Pointer Method Using the IBox Instruction Available in DirectSOFT6	4-11

Scale Conversions	4-11
Scaling the Input Data	4-11
The Conversion Program in Standard Ladder Logic.....	4-12
Analog and Digital Value Conversions	4-13
Module Resolution	4-14
Analog Data Bits.....	4-14
Resolution Details	4-14
Analog Input Ladder Logic Filter	4-15
PID Loops / Filtering.....	4-15
Smoothing the Input Signal (DL06 only).....	4-15
Binary Data Format Filter Using Ladder Logic	4-15
BCD Data Format Filter Using Ladder Logic.....	4-16
Example Code to Scale a 4–20 mA Signal to 0–1000 BCD	4-17
Example Code to Scale a 4–20 mA Signal to 0–1000 Binary	4-18

Chapter 5 - F0-04AD-2, 4-Channel Analog Voltage Input

Module Specifications	5-2
Setting the Module Jumpers	5-4
Connecting and Disconnecting the Field Wiring	5-5
Wiring Guidelines	5-5
Wiring Diagram	5-5
Module Operation	5-6
Input Channel Update Sequence.....	5-6
Analog Module Updates.....	5-6
Special V-memory Locations	5-7
Formatting the Module Data.....	5-7
DL05 Data Formatting	5-7
Structure of V7700	5-7
Structure of V7701	5-7
DL06 Data Formatting	5-8
Setup Data Type and Number of Channels	5-8
Storage Pointer Setup	5-8

Table of Contents

Using the Pointer in Your Control Program	5-9
DL05 Pointer Method.....	5-9
DL06 Pointer Method.....	5-10
Scale Conversions	5-11
Scaling the Input Data	5-11
The Conversion Program.....	5-12
Analog and Digital Value Conversions	5-13
Module Resolution	5-14
Analog Data Bits.....	5-14
Resolution Details	5-14
Analog Input Ladder Logic Filter	5-15
PID Loops / Filtering:.....	5-15
Smoothing the Input Signal (DL06 only):.....	5-15
Using Binary Data Format	5-15
Using BCD Data Format	5-16

Chapter 6 - F0-08ADH-2, 8-Channel Analog Voltage Input

Module Specifications	6-2
Setting the Module Jumpers	6-4
Locating the jumpers	6-4
Setting the appropriate jumper	6-4
Connecting and Disconnecting the Field Wiring	6-5
Wiring Guidelines	6-5
Wiring Diagram	6-6
Module Operation	6-7
Channel Scanning Sequence	6-7
Analog Module Updates.....	6-7
Special V-memory Locations	6-8
Formatting the Analog Module Data.....	6-8
DL05 Data Formatting	6-8
Setup Data Type and Number of Active Channels.....	6-8
Storage Pointer Setup	6-8
DL06 Data Formatting	6-9
Setup Data Type and Number of Active Channels.....	6-9
Storage Pointer Setup	6-9

Using the Pointer in Your Control Program 6–10

- DL05 Pointer Method Using Conventional Ladder Logic 6–10
- DL05 Pointer Method Using the IBox Instruction Available in DirectSOFT5 6–10
- DL06 Pointer Method Using Conventional Ladder Logic 6–11
- DL06 Pointer Method Using the IBox Instruction Available in DirectSOFT5 6–12

Scale Conversions 6–12

- Scaling the Input Data 6–12
- The Conversion Program in Standard Ladder Logic 6–13
- Analog and Digital Value Conversions 6–14

Module Resolution..... 6–15

- Analog Data Bits..... 6–15
- Resolution Details..... 6–15

Analog Input Ladder Logic Filter 6–16

- PID Loops / Filtering..... 6–16
- Smoothing the Input Signal (DL06 only) 6–16
- Binary Data Format Filter Using Ladder Logic 6–16
- Using BCD Data Format 6–17

Chapter 7 - F0-04DAH-1, 4-Channel Analog Current Output

Module Specifications 7–2

Connecting and Disconnecting the Field Wiring 7–4

- Wiring Guidelines 7–4

Wiring Diagram 7–5

Module Operation 7–6

- Channel Scanning Sequence 7–6

Special V-memory Locations 7–7

- Formatting the Analog Module Data 7–7
- DL05 Data Formatting 7–7
- Data Type and Number of Active Channels Setup 7–7
- Storage Pointer Setup 7–7
- DL06 Data Formatting 7–8
- Data Type and Number of Active Channels Setup 7–8
- Storage Pointer Setup 7–8

Using the Pointer in Your Control Program	7-9
DL05 Pointer Method Using Conventional Ladder Logic	7-9
DL05 Pointer Method Using the IBox Instruction Available in DirectSOFT5	7-9
DL06 Pointer Method Using Conventional Ladder Logic	7-10
DL06 Pointer Method Using the IBox Instruction Available in DirectSOFT5	7-11
Output Scale Conversion	7-11
Calculating the Digital Output Value	7-11
The Conversion Program in Standard Ladder Logic	7-12
Analog and Digital Value Conversions	7-13
Module Resolution	7-14
Analog Data Bits	7-14
Resolution Details	7-14

Chapter 8 - F0-08DAH-1, 8-Channel Analog Current Output

Module Specifications	8-2
Connecting and Disconnecting the Field Wiring	8-4
Wiring Guidelines	8-4
Wiring Diagram	8-5
Module Operation	8-6
Channel Scanning Sequence	8-6
Special System V-memory Locations	8-7
Formatting the Analog Module Data	8-7
DL05 Data Formatting	8-7
Data Type and Number of Active Channels Setup	8-7
Storage Pointer Setup	8-7
DL06 Data Formatting	8-8
Data Type and Number of Active Channels Setup	8-8
Storage Pointer Setup	8-8
Using the Pointer in Your Control Program	8-9
DL05 Pointer Method Using Conventional Ladder Logic	8-9
DL05 Pointer Method Using the IBox Instruction Available in DirectSOFT6	8-9
DL06 Pointer Method Using Conventional Ladder Logic	8-10
DL06 Pointer Method Using the IBox Instruction Available in DirectSOFT5	8-11

Output Scale Conversion..... 8-11
 Calculating the Digital Output Value 8-11
 The Conversion Program in Standard Ladder Logic..... 8-12
 Analog and Digital Value Conversions 8-13
Module Resolution..... 8-14
 Analog Data Bits..... 8-14
 Resolution Details 8-14

Chapter 9 - F0-04DAH-2, 4-Channel Analog Voltage Output

Module Specifications 9-2
Connecting and Disconnecting the Field Wiring 9-4
 Wiring Guidelines 9-4
Wiring Diagram 9-5
Module Operation 9-6
 Channel Scanning Sequence 9-6
Special V-memory Locations 9-7
 Formatting the Analog Module Data..... 9-7
 DL05 Data Formatting 9-7
 Data Type and Number of Active Channels Setup..... 9-7
 Storage Pointer Setup 9-7
 DL06 Data Formatting 9-8
 Data Type and Number of Active Channels Setup..... 9-8
 Storage Pointer Setup 9-8
Using the Pointer in Your Control Program 9-9
 DL05 Pointer Method Using Conventional Ladder Logic 9-9
 DL05 Pointer Method Using the IBox Instruction Available in DirectSOFT6 9-9
 DL06 Pointer Method Using Conventional Ladder Logic 9-10
 DL06 Pointer Method Using the IBox Instruction Available in DirectSOFT6 9-11
Output Scale Conversion..... 9-11
 Calculating the Digital Output Value 9-11
 The Conversion Program in Standard Ladder Logic..... 9-12
 Analog and Digital Value Conversions 9-13

Module Resolution	9-14
Analog Data Bits.....	9-14
Resolution Details.....	9-14

Chapter 10 - F0-08DAH-2, 8-Channel Analog Voltage Output

Module Specifications	10-2
Connecting and Disconnecting the Field Wiring	10-4
Wiring Guidelines	10-4
Wiring Diagram	10-5
Module Operation	10-6
Channel Scanning Sequence	10-6
Special V-memory Locations	10-7
Formatting the Analog Module Data.....	10-7
DL05 Data Formatting	10-7
Data Type and Number of Active Channels Setup.....	10-7
Storage Pointer Setup	10-7
DL06 Data Formatting	10-8
Data Type and Number of Active Channels Setup.....	10-8
Storage Pointer Setup	10-8
Using the Pointer in Your Control Program	10-9
DL05 Pointer Method Using Conventional Ladder Logic	10-9
DL05 Pointer Method Using the IBox Instruction Available in DirectSOFT6	10-9
DL06 Pointer Method Using Conventional Ladder Logic	10-10
DL06 Pointer Method Using the IBox Instruction Available in DirectSOFT6	10-11
Output Scale Conversion	10-11
Calculating the Digital Output Value	10-11
The Conversion Program in Standard Ladder Logic.....	10-12
Analog and Digital Value Conversions	10-13
Module Resolution	10-14
Analog Data Bits.....	10-14
Resolution Details.....	10-14

Chapter 11 - F0-4AD2DA-1, 4-Channel In/2-Ch. Out Analog Current Combination

Module Specifications	11-2
Setting the Module Jumper.....	11-4
Connecting and Disconnecting the Field Wiring	11-5
Wiring Guidelines	11-5
Wiring Diagram	11-6
Current Loop Transmitter Impedance.....	11-6
Module Operation	11-7
Input/Output Channel Update Sequence	11-7
Analog Module Updates.....	11-7
Special V-memory Locations	11-8
Formatting the Module Data.....	11-8
DL05 Data Formatting	11-8
Structure of V7700	11-8
Structure of V7701	11-8
Structure of V7702.....	11-9
DL06 Data Formatting	11-10
Setup Data Type and Number of Channels	11-10
Input Storage Pointer Setup	11-10
Output Storage Pointer Setup	11-10
Using the Pointer in Your Control Program	11-11
DL05 Pointer Method.....	11-11
DL06 Pointer Method.....	11-12
Scale Conversions	11-13
Scaling the Input Data	11-13
The Conversion Program.....	11-14
Output Conversion Program	11-14
Analog and Digital Value Conversions	11-15
Special Relays.....	11-16
DL05 Special Relays.....	11-16
DL06 Special Relays.....	11-16

Module Resolution	11-18
Analog Data Bits.....	11-18
Resolution Details.....	11-18
Analog Input Ladder Logic Filter	11-19
PID Loops / Filtering.....	11-19
Smoothing the Input Signal (DL06 only).....	11-19
Using Binary Data Format	11-19
Using BCD Data Format	11-20

Chapter 12 - F0-2AD2DA-2, 2-Channel In/2-Ch. Out Analog Voltage Combination

Module Specifications	12-2
Setting the Module Jumpers	12-4
Connecting and Disconnecting the Field Wiring	12-5
Wiring Guidelines	12-5
Wiring Diagram	12-5
Module Operation	12-6
Input/Output Channel Scanning Sequence	12-6
Analog Module Updates.....	12-6
Special V-memory Locations	12-7
Formatting the Module Data.....	12-7
DL05 Data Formatting	12-7
Structure of V7700.....	12-7
Structure of V7701	12-7
Structure of V7702.....	12-8
DL06 Data Formatting	12-9
Setup Data Type and Number of Channels	12-9
Input Storage Pointer	12-9
Output Storage Pointer	12-9
Using the Pointer in Your Control Program	12-10
DL05 Pointer Method.....	12-10
DL06 Pointer Method.....	12-11
Scale Conversions	12-12
Scaling the Input Data	12-12

The Conversion Program.....	12-13
Output Conversion Program	12-13
Analog and Digital Value Conversions	12-14
Module Resolution.....	12-15
Analog Data Bits.....	12-15
Analog Input Ladder Logic Filter	12-16
PID Loops / Filtering.....	12-16
Smoothing the Input Signal (DL06 only).....	12-16
Using Binary Data Format	12-16
Using BCD Data Format	12-17

Chapter 13 - F0-4AD2DA-2, 4-Channel In/2-Ch. Out Analog Voltage Combination

Module Specifications	13-2
Setting the Module Jumpers	13-4
Connecting and Disconnecting the Field Wiring	13-5
Wiring Guidelines	13-5
Wiring Diagram	13-5
Module Operation	13-6
Input/Output Channel Update Sequence	13-6
Analog Module Updates.....	13-6
Special V-memory Locations	13-7
Formatting the Module Data.....	13-7
DL05 Data Formatting	13-7
Structure of V7700.....	13-7
Structure of V7701	13-7
Structure of V7702.....	13-8
DL06 Data Formatting	13-9
Setup Data Type and Number of Channels	13-9
Input Storage Pointer Setup	13-9
Output Storage Pointer Setup	13-9
Using the Pointer in Your Control Program	13-10
DL05 Pointer Method.....	13-10
DL06 Pointer Method.....	13-11

Table of Contents

Scale Conversions	13-12
Scaling the Input Data	13-12
The Conversion Program	13-13
Output Conversion Program	13-13
Analog and Digital Value Conversions	13-14
Module Resolution	13-15
Analog Data Bits	13-15
Resolution Details	13-15
Analog Input Ladder Logic Filter	13-16
PID Loops / Filtering	13-16
Smoothing the Input Signal (DL06 only)	13-16
Using Binary Data Format	13-16
Using BCD Data Format	13-17

Chapter 14 - F0-04RTD, 4-Channel RTC Input

Module Specifications	14-2
Module Calibration	14-3
Input Specifications	14-3
Connecting and Disconnecting the Field Wiring	14-4
Wiring Guidelines	14-4
RTD - Resistance Temperature Detector	14-4
Ambient Variations in Temperature	14-5
Wiring Diagram	14-5
Module Operation	14-6
Channel Scanning Sequence	14-6
Analog Module Update	14-6
Special V-memory Locations	14-7
Module Configuration Registers	14-7
A: Number of Channels Enabled/Data Format Register	14-7
B: Input Pointer Register	14-8
C: RTD Type Selection Register	14-8
D: Units Code Register	14-9
E: RTD Burnout Data Value Register	14-10
F: Diagnostics Error Register	14-10

Configuring the Module in Your Control Program	14-11
DL05 Example 1	14-11
DL05 Example 2	14-12
DL06 Example 1	14-13
DL06 Example 2	14-14
Negative Temperature Readings with Magnitude Plus Sign	14-15
Magnitude Plus Sign (Binary)	14-15
Magnitude Plus Sign (BCD)	14-16
Negative Temperatures 2's Complement (Binary/Pointer Method)	14-17
Analog Input Ladder Logic Filter	14-18
PID Loops / Filtering	14-18
Smoothing the Input Signal (DL06 only)	14-18
Using Binary Data Format	14-18
Using BCD Data Format	14-19
RTD Burnout Detection Bits	14-20
Special Relays Corresponding to RTD Burnouts	14-20

Chapter 15 - F0-04THM, 4-Channel Thermocouple Input

Module Specifications	15-2
Connecting and Disconnecting the Field Wiring	15-4
Wiring Guidelines	15-4
Thermocouple Input Wiring Diagram	15-4
Thermocouples	15-5
Ambient Variations in Temperature	15-5
Voltage Input Wiring Diagram	15-6
Module Operation	15-7
Channel Scanning Sequence	15-7
Analog Module Update	15-7
Special V-memory Locations	15-8
Module Configuration Registers	15-8
A: Number of Channels Enabled/Data Format Register	15-8
B: Input Pointer Register	15-9
C: Input Type Selection Register	15-9
D: Units Code Register	15-10

Table of Contents

E: Thermocouple Burnout Detection Enable Register.....	15-11
F: Thermocouple Burnout Data Value Register.....	15-11
G: Diagnostics Error Register	15-11
Configuring the Module in Your Control Program	15-12
DL05 Example 1	15-12
DL05 Example 2.....	15-13
DL06 Example 1	15-14
DL06 Example 2.....	15-15
Negative Temperature Readings with Magnitude Plus Sign	15-16
Magnitude Plus Sign (Binary)	15-16
Magnitude Plus Sign (BCD).....	15-17
Module Resolution.....	15-18
Module Resolution 16-Bit (Unipolar Voltage Input)	15-18
Module Resolution 15-Bit Plus Sign (Bipolar Voltage Input).....	15-18
Analog Input Ladder Logic Filter	15-19
PID Loops / Filtering.....	15-19
Smoothing the Input Signal (DL06 only).....	15-19
Using Binary Data Format	15-19
Using BCD Data Format	15-20
Thermocouple Burnout Detection Bits	15-21
Special Relays Corresponding to Thermocouple Burnouts	15-21

GETTING STARTED



CHAPTER 1

In This Chapter...

Introduction.....	1-2
Conventions Used.....	1-2
Selecting the Proper Module	1-3
Installing the Option Modules	1-5
Module LED Indicator.....	1-6
Power Budgeting.....	1-6

Introduction

The Purpose of this Manual

This manual will describe the option modules that are available for the DL05 and DL06 micro PLC families. It will show you how to select and install an option module for your PLC.

Supplemental Manuals

You will either need a copy of the **DL05 User Manual** (D0-USER-M) or the **DL06 User Manual** (D0-06USER-M) at hand when incorporating any one of the option modules in your PLC.

Technical Support

We strive to make our manuals the best in the industry. We rely on your feedback to let us know if we are reaching our goal. If you cannot find the solution to your particular application, or, if for any reason you need technical assistance, please call us at:

770-844-4200

Our technical support group will work with you to answer your questions. They are available Monday through Friday from 9:00 A.M. to 6:00 P.M. Eastern Time. We also encourage you to visit our web site where you can find technical and non-technical information about our products and our company.

<http://www.automationdirect.com>

If you have a comment, question or suggestion about any of our products, services, or manuals, please fill out and return the 'Suggestions' card that was included with this manual.

Conventions Used



*When you see the “notepad” icon in the left-hand margin, the paragraph to its immediate right will be a special note. The word **NOTE**: in boldface will mark the beginning of the text.*



*When you see the “exclamation mark” icon in the left-hand margin, the paragraph to its immediate right will be a warning. This information could prevent injury, loss of property, or even death (in extreme cases). The word **WARNING**: in boldface will mark the beginning of the text.*

Key Topics for Each Chapter

The beginning of each chapter will list the key topics that can be found in that chapter.

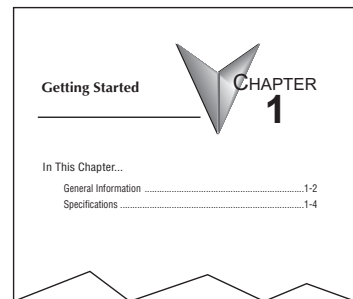

Selecting the Proper Module

DL05

The DL05 Micro PLC only has one option slot to install an option module. The proper selection of a module is dependent on the control application.



DL06

The DL06 Micro PLC has four option slots. The option modules can also be added according to the control application.

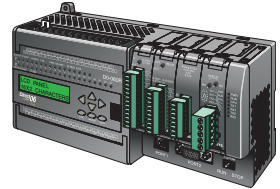

Module Choices

There are over thirty option modules available. The specifications and wiring diagrams for the discrete I/O modules can be found in the next chapter. A full description of the analog modules can be found in their respective chapters in this manual. The memory cartridge module, D0-01MC, can be found in the DL05 Micro PLC User Manual. The communications and specialty modules are described in their respective user manuals, see user manual p/n reference below. The following table lists the modules available.

Discrete Modules	
Part Number	Description
F0-08SIM	8 point Simulator Input
D0-10ND3	10 point DC Input
D0-10ND3F	10 point fast DC Input
D0-16ND3	16 point DC Input
F0-08NA-1	8 point AC Input
D0-10TD1	10 point DC Output (sinking)
D0-16TD1	16 point DC Output (sinking)
D0-10TD2	10 point DC Output (sourcing)
D0-16TD2	16 point DC Output (sourcing)
D0-07CDR	4 point DC Input, 3 point Relay Output
D0-08TR	8 point Relay Output
D0-08CDD1	4 point DC Input, 4 point DC Output (sinking)
F0-04TRS	4 point High Current Relay Output

Analog and Specialty module choices can be found on the next page.

Module Choices, continued.

Analog Modules	
Part Number	Description
F0-04AD-1	4-Channel Analog Input, Current
F0-04AD-2	4-Channel Analog Input, Voltage
F0-08ADH-1	8-Channel High-Resolution Analog Input, Current
F0-08ADH-2	8-Channel High-Resolution Analog Input, Voltage
F0-04DAH-1	4-Channel High-Resolution Analog Output, Current
F0-04DAH-2	4-Channel High-Resolution Analog Output, Voltage
F0-08DAH-1	8-Channel High-Resolution Analog Output, Current
F0-08DAH-2	8-Channel High-Resolution Analog Output, Voltage
F0-2AD2DA-2	2-Channel Input/2-Channel Output Analog Combination, Voltage
F0-4AD2DA-1	4-Channel Input/2-Channel Output Analog Combination, Current
F0-4AD2DA-2	4-Channel Input/2-Channel Output Analog Combination, Voltage
F0-04RTD	4-Channel RTD Input
F0-04THM	4-Channel Thermocouple Input

Specialty Modules	
Part Number	Description
D0-01MC	Memory Cartridge/Real Time Clock (DL05 only) (see User Manual p/n D0-USER-M)
D0-DCM	Data Communications Module
D0-DEVNETS	DeviceNet Slave (User Manual p/n D0-DEVNETS-M)
H0-ECOM(100)	10Base-T (10/100Base-T) Ethernet Network (User Manual p/n HX-ECOM-M)
H0-PSCM	Profibus Slave Communications (User Manual p/n HX-PSCM-M)
H0-CTRIO	High Speed Counter Interface (User Manual p/n HX-CTRIO-M)
F0-CP128	Triple Port Basic CoProcessor (User Manual p/n F0-CP-M)

Installing the Option Modules

Before installing the option module in the DL05 option slot or the DL06 option slots set the necessary jumpers and/or dip switches on the module. Refer to the chapter(s) that pertains to the module(s) being installed.

Remove the Slot Cover

The first step in installing the option module is to remove the protective option slot cover. Remove the cover by squeezing the pinch tabs and lifting the cover off.

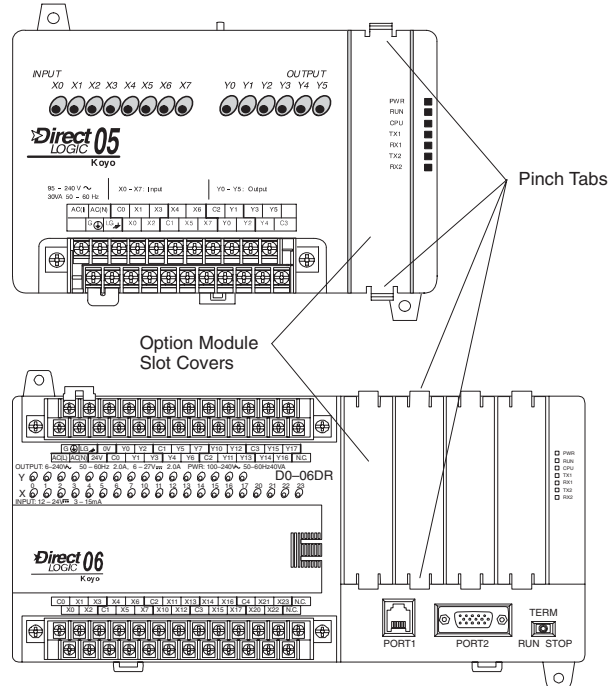

Insert the Module

Now, insert the module into the open slot. Locate the module so the printed information is oriented in the same direction as the markings on the PLC. Be careful to align the female connector on the printed circuit board of the module with the male connector on the PLC mother board. Press the module into the slot until the front of the module is flush with the front of the PLC. Install the remaining modules in the DL06. Once the modules are in place the PLC is ready to be programmed.



WARNING: Power to the PLCs must be disconnected before inserting or removing a module. Failure to disconnect power could result in serious damage to a module, the PLC or both.

Module LED Indicator

Most discrete I/O Option modules have an LED indicator. The indicator flickers or stays constant while the CPU is accessing the module, whether in program mode or run mode. It is not a diagnostics indicator, therefore the on status is not an indication the I/O module is functioning properly.

Power Budgeting

The DL06 has four option card slots. To determine whether the combination of cards you select will have sufficient power, you will need to perform a power budget calculation.

Power supplied

Power is supplied from two sources, the internal base unit power supply and, if required, an external supply (customer furnished). The D0-06xx (AC powered) PLCs supply a limited amount of 24VDC power. The 24VDC output can be used to power external devices. For power budgeting, start by considering the power supplied by the base unit. All DL06 PLCs supply the same amount of 5VDC power. Only the AC units offer 24VDC auxiliary power. Be aware of the trade-off between 5VDC power and 24VDC power. The amount of 5VDC power available depends on the amount of 24VDC power being used, and the amount of 24VDC power available depends on the amount of 5VDC power consumed. Determine the amount of internally supplied power from the table on the following page.

Power required by base unit

Because of the different I/O configurations available in the DL06 family, the power consumed by the base unit itself varies from model to model. Subtract the amount of power required by the base unit from the amount of power supplied by the base unit. Be sure to subtract 5VDC and 24VDC amounts.

Power required by option cards

Next, subtract the amount of power required by the option cards you are planning to use. Again, remember to subtract both 5VDC and 24VDC. If your power budget analysis shows surplus power available, you should have a workable configuration.

DL06 Power Supplied by Base Units		
Part Number	5 VDC (mA)	24 VDC (mA)
D0-06xx	<1500mA	300mA
	<2000mA	200mA
D0-06xx-D	1500mA	none

DL05/06 Power Consumed by Option Cards		
Part Number	5 VDC (mA)	24 VDC (mA)
D0-07CDR	130mA	none
D0-08CDD1	100mA	none
D0-08TR	280mA	none
D0-10ND3	35mA	none
D0-10ND3F	35mA	none
D0-10TD1	150mA	none
D0-10TD2	150mA	none
D0-16ND3	35mA	none
D0-16TD1	200mA	none
D0-16TD2	200mA	none
F0-04TRS	250mA	none
F0-08NA-1	5mA	none
F0-04AD-1	50mA	none
F0-04AD-2	75mA	none
F0-2AD2DA-2	50mA	30mA
F0-4AD2DA-1	100mA	40mA
F0-4AD2DA-2	100mA	none
F0-04RTD	70mA	none
F0-04THM	30mA	none
F0-08SIM	1mA	none
F0-08ADH-1	25mA	25mA
F0-08ADH-2	25mA	25mA
F0-04DAH-1	25mA	150mA
F0-08DAH-1	25mA	220mA
F0-04DAH-2	25mA	25mA
F0-08DAH-2	25mA	25mA
D0-01MC	used only in DL05	
D0-DCM	250mA	none
D0-DEVNETS	45mA	none
H0-PSCM	530mA	none
H0-ECOM	250mA	none
H0-ECOM100	300mA	none
H0-CTRIO	250mA	none
F0-CP128	150mA	none

DL06 Base Unit Power Required		
Part Number	5 VDC (mA)	24 VDC (mA)
D0-06AA	800mA	none
D0-06AR	900mA	none
D0-06DA	800mA	none
D0-06DD1	600mA	280mA*
D0-06DD2	600mA	none
D0-06DR	950mA	none
D0-06DD1-D	600mA	280mA*
D0-06DD2-D	600mA	none
D0-06DR-D	950mA	none

* Auxiliary 24VDC used to power V+ terminal of D0-06DD1/-D sinking outputs.

DL05/DL06 Power Consumed by Other Devices		
Part Number	5 VDC (mA)	24 VDC (mA)
D0-06LCD	50mA	none
D2-HPP	200mA	none
DV1000	150mA	none
EA1-S3ML	220mA	none

Power Budgeting Example			
Power Source		5VDC power (mA)	24VDC power (mA)
D0-06DD1 (select row A or row B)	A	1500mA	300mA
	B	2000mA	200mA
Current Required		5VDC power (mA)	24VDC power (mA)
D0-06DD1		600mA	280mA*
D0-16ND3		35mA	0
D0-10TD1		150mA	0
D0-08TR		280mA	0
F0-4AD2DA-2		100mA	0
D0-06LCD		50mA	0
Total Used		1215mA	280mA
Remaining	A	285mA	20mA
	B	785mA	Note 1



NOTE 1: If the PLC's auxiliary 24VDC power source is used to power the sinking outputs, use power choice A, above.

DISCRETE I/O GUIDELINES



CHAPTER 2

In This Chapter...

Safety Guidelines	2-2
System Wiring Strategies	2-5
I/O Addressing.....	2-15
Discrete I/O General Specifications	2-17
Glossary of Specification Terms	2-18
F0-08SIM 8-Point Simulator Input Module.....	2-19
D0-10ND3 10-Point DC Input Module.....	2-20
D0-10ND3F 10-Point DC Fast Input Module	2-21
D0-16ND3 16-Point DC Input Module.....	2-22
F0-08NA-1 8-Point AC Input Module	2-23
D0-10TD1 10-Point DC Output Module.....	2-24
D0-16TD1 16-Point DC Output Module.....	2-25
D0-10TD2 10-Point DC Output Module.....	2-26
D0-16TD2 16-Point DC Output Module.....	2-27
D0-07CDR 4-Point DC Input, 3-Point Relay Output Module.....	2-28
D0-08TR 8-Point Relay Output Module	2-29
D0-08CDD1 4-Point DC Input, 4-Point DC Output Module.....	2-30
F0-04TRS 4-Point Relay Output Module	2-31

Safety Guidelines



NOTE: Products with CE marks perform their required functions safely and adhere to relevant standards as specified by CE directives provided they are used according to their intended purpose and that the instructions in this manual are adhered to. The protection provided by the equipment may be impaired if this equipment is used in a manner not specified in this manual. A listing of our international affiliates is available on our Web site: <http://www.automationdirect.com>



WARNING: Providing a safe operating environment for personnel and equipment is your responsibility and should be your primary goal during system planning and installation. Automation systems can fail and may result in situations that can cause serious injury to personnel or damage to equipment. Do not rely on the automation system alone to provide a safe operating environment. You should use external electromechanical devices, such as relays or limit switches, that are independent of the PLC application to provide protection for any part of the system that may cause personal injury or damage. Every automation application is different, so there may be special requirements for your particular application. Make sure you follow all national, state, and local government requirements for the proper installation and use of your equipment.

Plan for Safety

The best way to provide a safe operating environment is to make personnel and equipment safety part of the planning process. You should examine every aspect of the system to determine which areas are critical to operator or machine safety. If you are not familiar with PLC system installation practices, or your company does not have established installation guidelines, you should obtain additional information from the following sources.

- NEMA — The National Electrical Manufacturers Association, located in Washington, D.C. publishes many different documents that discuss standards for industrial control systems. You can order these publications directly from NEMA. Some of these include:
 - *ICS 1, General Standards for Industrial Control and Systems*
 - *ICS 3, Industrial Systems*
 - *ICS 6, Enclosures for Industrial Control Systems*
- NEC — The National Electrical Code provides regulations concerning the installation and use of various types of electrical equipment. Copies of the NEC Handbook can often be obtained from your local electrical equipment distributor or your local library.
- Local and State Agencies — many local governments and state governments have additional requirements above and beyond those described in the NEC Handbook. Check with your local Electrical Inspector or Fire Marshall office for information.

Three Levels of Protection

The publications mentioned provide many ideas and requirements for system safety. At a minimum, you should follow these regulations. Also, you should use the following techniques, which provide three levels of system control.

- Emergency stop switch for disconnecting system power
- Mechanical disconnect for output module power
- Orderly system shutdown sequence in the PLC control program

Emergency Stops

It is recommended that emergency stop circuits be incorporated into the system for every machine controlled by a PLC. For maximum safety in a PLC system, these circuits must not be wired into the controller, but should be hardwired external to the PLC. The emergency stop switches should be easily accessed by the operator and are generally wired into a master control relay (MCR) or a safety control relay (SCR) that will remove power from the PLC I/O system in an emergency.

MCRs and SCRs provide a convenient means for removing power from the I/O system during an emergency situation. By de-energizing an MCR (or SCR) coil, power to the input (optional) and output devices is removed. This event occurs when any emergency stop switch opens. However, the PLC continues to receive power and operate even though all its inputs and outputs are disabled.

The MCR circuit could be extended by placing a PLC fault relay (closed during normal PLC operation) in series with any other emergency stop conditions. This would cause the MCR circuit to drop the PLC I/O power in case of a PLC failure (memory error, I/O communications error, etc.).

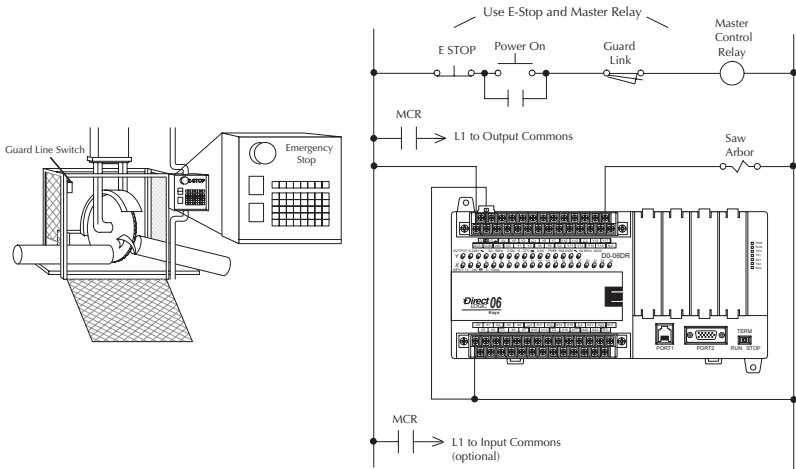

Emergency Power Disconnect

A properly rated emergency power disconnect should be used to power the PLC controlled system as a means of removing the power from the entire control system. It may be necessary to install a capacitor across the disconnect to protect against a condition known as “outrush”. This condition occurs when the output Triacs are turned off by powering off the disconnect, thus causing the energy stored in the inductive loads to seek the shortest distance to ground, which is often through the Triacs.

After an emergency shutdown or any other type of power interruption, there may be requirements that must be met before the PLC control program can be restarted. For example, there may be specific register values that must be established (or maintained from the state prior to the shutdown) before operations can resume. In this case, you may want to use retentive memory locations, or include constants in the control program to insure a known starting point.

Orderly System Shutdown

Ideally, the first level of fault detection is the PLC control program, which can identify machine problems. Certain shutdown sequences should be performed. The types of problems are usually things such as jammed parts, etc. that do not pose a risk of personal injury or equipment damage.

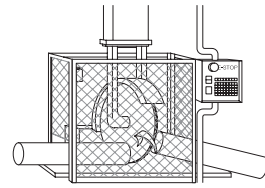

WARNING: The control program must not be the only form of protection for any problems that may result in a risk of personal injury or equipment damage.

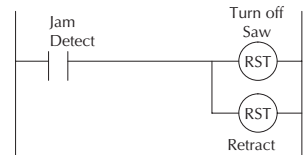

Class 1, Division 2 Approval (Applies ONLY to modules used with a DL06 PLC.)

This equipment is suitable for use in Class 1, Division 2, groups A, B, C and D or non-hazardous locations only.



WARNING: Explosion Hazard! Substitution of components may impair suitability for Class 1, Division 2. Do not disconnect equipment unless power has been switched off or area is known to be non-hazardous.

System Wiring Strategies

The *Direct*LOGIC Micro PLCs are very flexible and will work in many different wiring configurations. By studying this section before actual installation, you can probably find the best wiring strategy for your application. This will help to lower system cost, wiring errors, and avoid safety problems.

PLC Isolation Boundaries

PLC circuitry is divided into three main regions separated by isolation boundaries, shown in the drawing below. Electrical isolation provides safety, so that a fault in one area does not damage another. A powerline filter will provide isolation between the power source and the power supply. A transformer in the power supply provides magnetic isolation between the primary and secondary sides. Opto-couplers provide optical isolation in Input and Output circuits. This isolates logic circuitry from the field side, where factory machinery connects. Note that the discrete inputs are isolated from the discrete outputs, because each is isolated from the logic side. Isolation boundaries protect the operator interface (and the operator) from power input faults or field wiring faults. When wiring a PLC, it is extremely important to avoid making external connections that connect logic side circuits to any other.

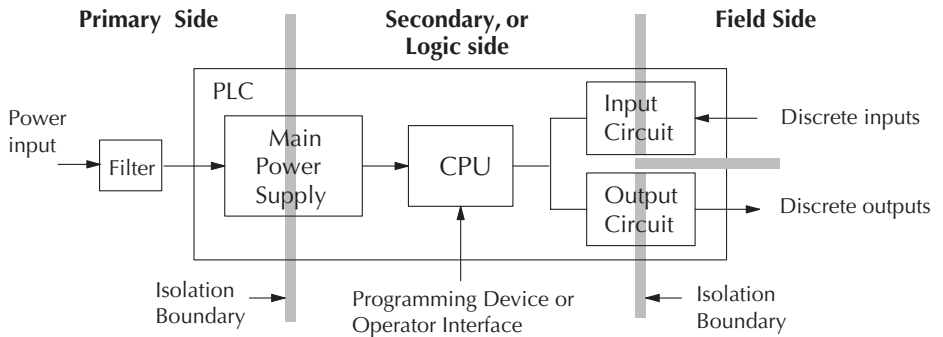

Chapter 2: Discrete I/O Guidelines

The following figures show the internal layout of the DL05 and DL06 PLCs, as viewed from the front panels.

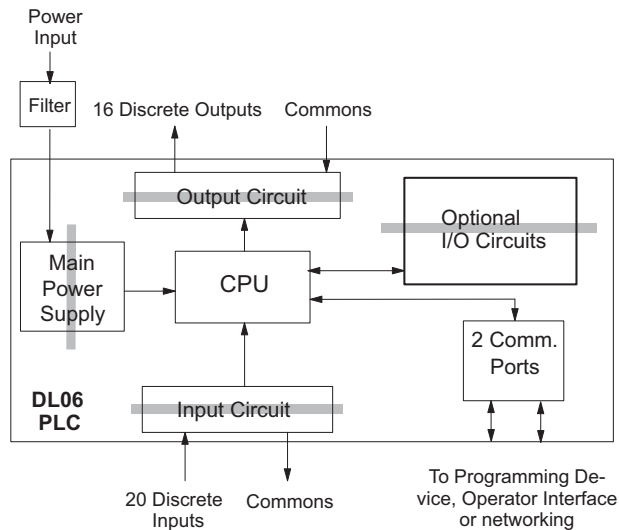
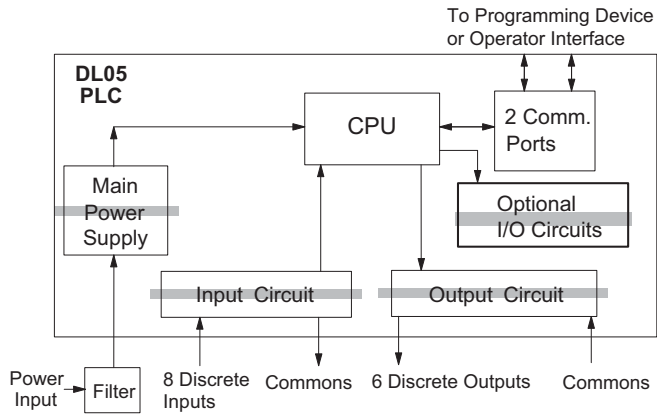

Sinking/Sourcing Concepts

Before going further in our study of wiring strategies, we must have a solid understanding of “sinking” and “sourcing” concepts. Use of these terms occurs frequently in input or output circuit discussions. It is the goal of this section to make these concepts easy to understand, further ensuring your success in installation. First we give the following short definitions, followed by practical applications.

- Sinking = Path to supply ground (-)
- Sourcing = Path to supply source (+)

First you will notice that these are only associated with DC circuits and not AC, because of the reference to (+) and (-) polarities. Therefore, *sinking and sourcing terminology only applies to DC input and output circuits*. Input and output points that are either sinking or sourcing can conduct current in only one direction. This means it is possible to connect the external supply and field device to the I/O point with current trying to flow in the wrong direction, and the circuit will not operate. However, we can successfully connect the supply and field device every time by understanding “sourcing” and “sinking”.

For example, the figure to the right depicts a “sinking” input. To properly connect the external supply, we just have to connect it so the input provides a path to ground (-). So, we start at the PLC input terminal, follow through the input sensing circuit, exit at the common terminal, and connect the supply (-) to the common terminal. By adding the switch, between the supply (+) and the input, we have completed the circuit. Current flows in the direction of the arrow when the switch is closed.

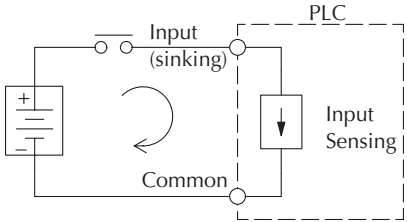

By applying the circuit principle above to the four possible combinations of input/output sinking/sourcing types, we have the four circuits as shown below. *DirectLOGIC* Micro PLCs provide all except the sourcing output I/O circuit types.

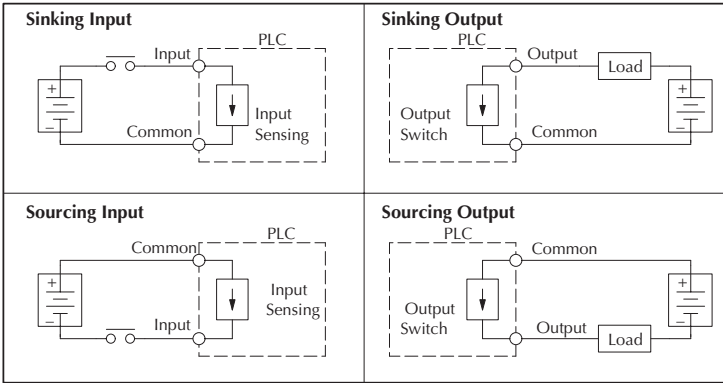

I/O “Common” Terminal Concepts

In order for a PLC I/O circuit to operate, current must enter at one terminal and exit at another. This means at least two terminals are associated with every I/O point. In the figure to the right, the Input or Output terminal is the main path for the current. One additional terminal must provide the return path to the power supply.

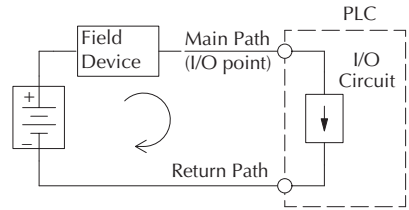

If we had unlimited space and budget for I/O terminals, then every I/O point could have two dedicated terminals just as the figure above shows. However, providing this level of flexibility is not practical or even necessary for most applications. So, most Input or Output point groups on PLCs share the return path among two or more I/O points. The figure to the right shows a group (or bank) of 4 input points which share a common return path. In this way, the four inputs require only five terminals instead of eight.

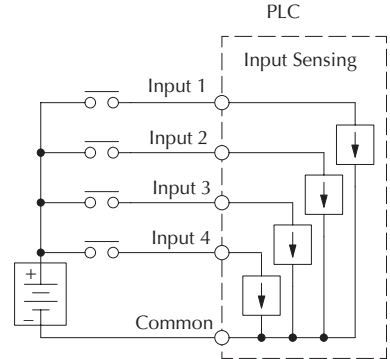

NOTE: In the circuit above, the current in the common path is equal to the sum of the energized channels. This is especially important in output circuits, where larger gauge wire is sometimes needed for the common.

Some of the input and output modules often share a common return path. The best indication of I/O common grouping is on the wiring label. The combination I/O module to the right is an exception. The inputs and the outputs have separate commons.

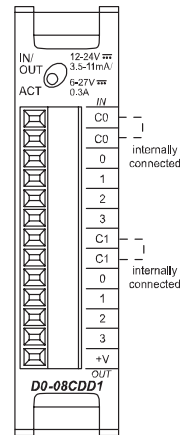

Connecting DC I/O to Solid State Field Devices

In the previous section on Sourcing/Sinking concepts, we explained that DC I/O circuits sometimes will only allow current to flow one way. This is also true for many of the field devices which have solid-state (transistor) interfaces. In other words, field devices can also be sourcing or sinking. *When connecting two devices in a series DC circuit, one must be wired as sourcing and the other as sinking.*

Solid State Input Sensors

The PLC DC inputs are flexible in that they detect current flow in either direction, so they can be wired as either sourcing or sinking. In the circuit below, a field device has an open-collector NPN transistor output. It sinks current from the PLC input point, which sources current. The source can be a FA-24PS, +24VDC, power supply or another supply (+12VDC or +24VDC) of your choice, as long as the input specifications are met.

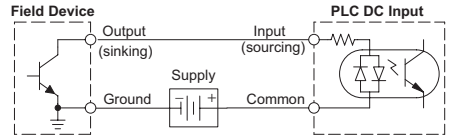

In the circuit at right, a field device has an open-emitter PNP transistor output. It sources current to the PLC input point, which sinks the current back to ground. Since the field device is sourcing current, no additional power supply is required.

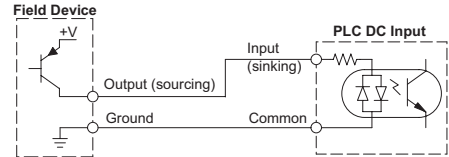

Solid State Output Loads

Sometimes an application requires connecting a PLC output point to a solid state input on a device. This type of connection is usually made to carry a low-level signal, not to send DC power to an actuator.

Some of the optional DC output modules are sinking-only. This means that each DC output provides a path to ground when it is energized. The six outputs of the DL05 have the same electrical common, even though there are two common terminal screws. Not so with the DL06 which has four isolated commons. Finally, recall that the DC output circuit requires power (20–28 VDC) from an external power source.

In the circuit at right, the PLC output point sinks current to the output common when energized. It is connected to a sourcing input of a field device input.

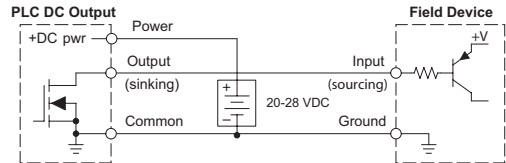

In the next example we connect a PLC DC output point to the sinking input of a field device. This is a bit tricky, because both the PLC output and field device input are sinking type. Since the circuit must have one sourcing and one sinking device, we add sourcing capability to the PLC output by using a pull-up resistor. In the circuit below, we connect R_{pull-up} from the output to the DC output circuit power input.

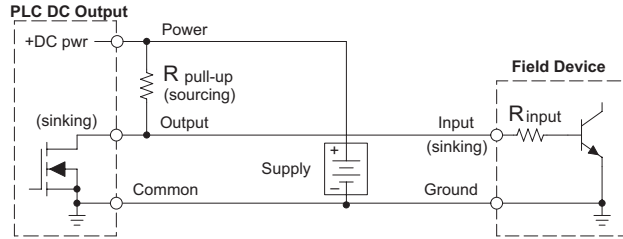

NOTE 1: DO NOT attempt to drive a heavy load (>25mA) with this pull-up method.

NOTE 2: Using the pull-up resistor to implement a sourcing output has the effect of inverting the output point logic. In other words, the field device input is energized when the PLC output is OFF, from a ladder logic point-of-view. Your ladder program must comprehend this and generate an inverted output. Or, you may choose to cancel the effect of the inversion elsewhere, such as in the field device.

It is important to choose the correct value of R_{pull-up}. In order to do so, we need to know the nominal input current to the field device (I_{input}) when the input is energized. If this value is not known, it can be calculated as shown (a typical value is 15mA). Then use I_{input} and the voltage of the external supply to compute R_{pull-up}. Then calculate the power P_{pull-up} (in watts), in order to size R_{pull-up} properly.

$$I_{\text{input}} = \frac{V_{\text{input (turn-on)}}}{R_{\text{input}}}$$

$$R_{\text{pull-up}} = \frac{V_{\text{supply}} - 0.7}{I_{\text{input}}} - R_{\text{input}}$$

$$P_{\text{pull-up}} = \frac{V_{\text{supply}}^2}{R_{\text{pull-up}}}$$

Of course, the easiest way to drive a sinking input field device as shown below is to use a DC sourcing output module. The Darlington NPN stage will have about 1.5 V ON-state saturation, but this is not a problem with low-current solid-state loads.

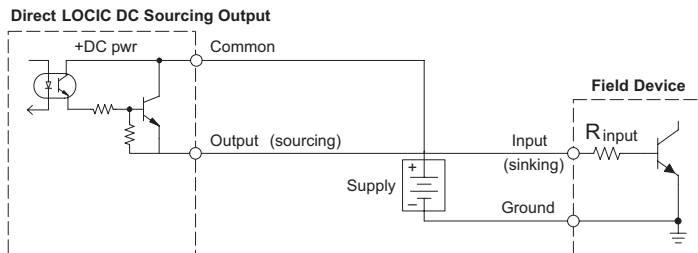

Relay Output Guidelines

Relay outputs are available for the *Direct*LOGIC PLCs. Relays are best for the following applications:

- Loads that require higher currents than the solid-state outputs can deliver
- Cost-sensitive applications
- Some output channels need isolation from other outputs (such as when some loads require different voltages than other loads)

Some applications in which NOT to use relays:

- Loads that require currents under 10mA
- Loads which must be switched at high speed or heavy duty cycle

Relay outputs in the *Direct*LOGIC PLCs and modules are available in two contact arrangements, shown to the right. The Form A type, or SPST (single pole, single throw) type is normally open and is the simplest to use. The Form C type, or SPDT (single pole, double throw) type has a center contact which moves and a stationary contact on either side. This provides a normally closed contact and a normally open contact.

Relay with Form A contacts

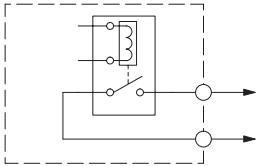

Relay with Form C contacts

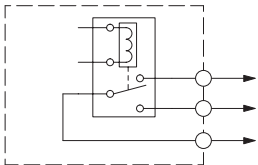

Some relay output module's relays share common terminals, which connect to the wiper contact in each relay of the bank. Other relay modules have relays which are completely isolated from each other. In all cases, the module drives the relay coil when the corresponding output point is on.

Prolonging Relay Contact Life

Relay contacts wear according to the amount of relay switching, amount of spark created at the time of open or closure, and presence of airborne contaminants. However, there are some steps you can take to help prolong the life of relay contacts:

- Switch the relay on or off only when the application requires it.
- If you have the option, switch the load on or off at a time when it will draw the least current.
- Take measures to suppress inductive voltage spikes from inductive DC loads such as contactors and solenoids (circuit given below).

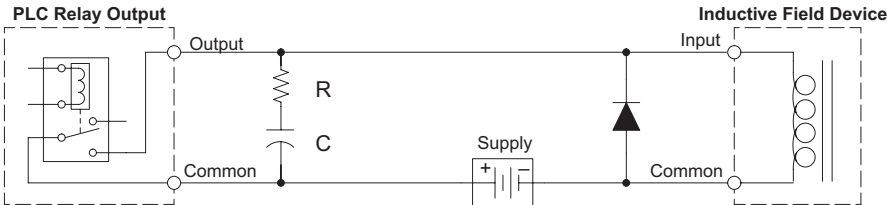

Surge Suppression For Inductive Loads

Inductive load devices (devices with a coil) generate transient voltages when de-energized with a relay contact. When a relay contact is closed it “bounces”, which energizes and de-energizes the coil until the “bouncing” stops. The transient voltages generated are much larger in amplitude than the supply voltage, especially with a DC supply voltage.

When switching a DC-supplied inductive load the full supply voltage is always present when the relay contact opens (or “bounces”). When switching an AC-supplied inductive load there is one chance in 60 (60Hz) or 50 (50Hz) that the relay contact will open (or “bounce”) when the AC sine wave is zero crossing. If the voltage is not zero when the relay contact opens there is energy stored in the inductor that is released when the voltage to the inductor is suddenly removed. This release of energy is the cause of the transient voltages.

When inductive load devices (motors, motor starters, interposing relays, solenoids, valves, etc.) are controlled with relay contacts, it is recommended that a surge suppression device be connected directly across the coil of the field device. If the inductive device has plug-type connectors, the suppression device can be installed on the terminal block of the relay output.

Transient Voltage Suppressors (TVS or transorb) provide the best surge and transient suppression of AC and DC powered coils, providing the fastest response with the smallest overshoot.

Metal Oxide Varistors (MOV) provide the next best surge and transient suppression of AC and DC powered coils.

For example, the waveform in the figure below shows the energy released when opening a contact switching a 24VDC solenoid. Notice the large voltage spike.

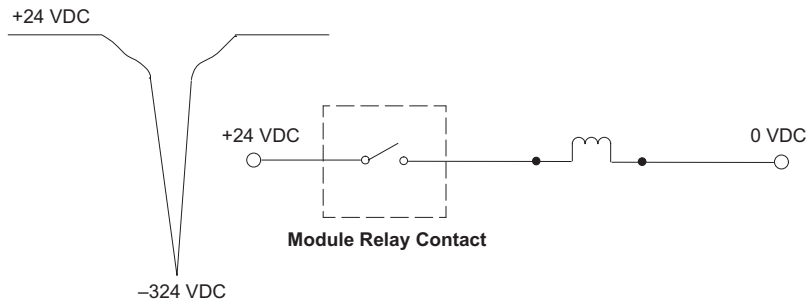

This figure shows the same circuit with a transorb (TVS) across the coil. Notice that the voltage spike is significantly reduced.

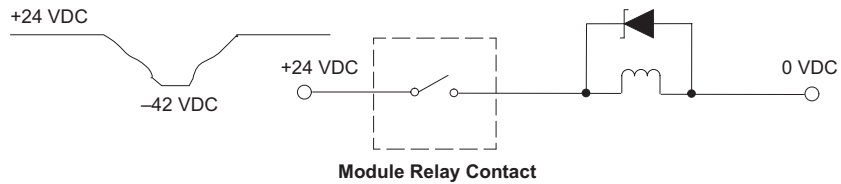

Use the following table to help select a TVS or MOV suppressor for your application based on the inductive load voltage.

Surge Suppressors			
Vendor / Catalog	Type	Inductive Load Voltage	Part Number
AutomationDirect	TVS	110/120 VAC	ZL-TD8-120
	TVS	24VDC	ZL-TD8-24
Transient Voltage Suppressors, LiteOn Diodes; from Digi-Key Catalog: Phone: 1-800-344-4539	TVS	220/240 VAC	P6KE350CA
	TVS	12/24 VDC	P6K30CAGICT-ND
	Diode	12/24 VDC	1N4004CT-ND
Digi-key www.digikey.com	MOV	110/120 VAC	Contact Digi-Key, Corp.
	MOV	220/240 VAC	

Prolonging Relay Contact Life

Relay contacts wear according to the amount of relay switching, amount of spark created at the time of open or closure, and presence of airborne contaminants. There are some steps you can take to help prolong the life of relay contacts, such as switching the relay on or off only when it is necessary, and if possible, switching the load on or off at a time when it will draw the least current. Also, take measures to suppress inductive voltage spikes from inductive DC loads such as contactors and solenoids.

For inductive loads in DC circuits we recommend using a suppression diode as shown in the following diagram (DO NOT use this circuit with an AC power supply). When the load is energized the diode is reverse-biased (high impedance). When the load is turned off, energy stored in its coil is released in the form of a negative-going voltage spike. At this moment the diode is forward-biased (low impedance) and shunts the energy to ground. This protects the relay contacts from the high voltage arc that would occur just as the contacts are opening.

Place the diode as close to the inductive field device as possible. Use a diode with a peak inverse voltage rating (PIV) at least 100 PIV, 3A forward current or larger. Use a fast-recovery type (such as Schottky type). DO NOT use a small-signal diode such as 1N914, 1N941, etc. Be sure the diode is in the circuit correctly before operation. If installed backwards, it short-circuits the supply when the relay energizes.

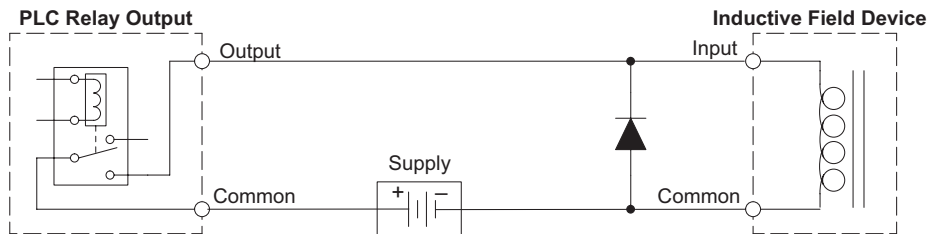

DC Input Wiring Methods

*Direct*LOGIC Micro PLCs with DC inputs are particularly flexible because they can be either sinking or sourcing. The dual diodes (shown to the right) allow current to flow in either direction. The inputs accept 10.8–26.4 VDC. The target applications are +12VDC and +24VDC. You can actually wire half of the inputs as DC sinking and the other half as DC sourcing. Inputs grouped by a common must be all sinking or all sourcing.

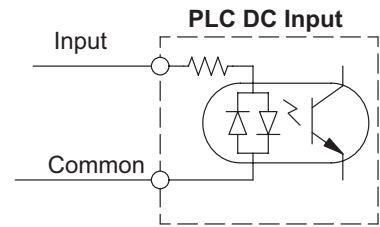

DC Output Wiring Methods

The PLC DC output circuits are high-performance transistor switches with low on-resistance and fast switching times. Please note the following characteristics which are unique to the DC output type:

- The DL05 has only one electrical common for all six outputs. All six outputs belong to one bank.
- The DL05 output switches are current-sinking only. However, you can still use different DC voltages from one load to another.
- The DL06 has isolated commons for each group of four outputs. There are two DL06 models with output switches that are current-sinking only, and one that has sourcing output switches.
- The output circuit inside the PLC requires external power. The supply (–) must be connected to a common terminal, and the supply (+) connects the right-most terminal on the upper connector.

Firmware and Software

The discrete option modules will only function properly in a DL05 with firmware version V4.10 (or later). If you have a DL05 with an earlier firmware version, the latest version can be downloaded from our website, www.automationdirect.com. If you are unable to download the latest firmware version along with the upgrade support tool software, call our technical support group to arrange to have your PLC upgraded.

The DL05 PLCs need to have *Direct*SOFT32 Version 3.0c (or later) in order for the analog feature to perform properly. The DL06 must use *Direct*SOFT32 Version 4.0 in order to use the option modules.

I/O Addressing

Module I/O Points and Addressing for the DL05 and DL06

Each discrete option module has a set number of I/O points. (This does not hold true for the analog modules). The following table shows the number of I/O points per module when used in the DL05 PLC or the first slot of a DL06 PLC that has a discrete module installed. Discrete I/O addressing for a DL06 is automatic from slot 1 to slot 4 by default.

DC Input Modules	Physical I/O Points	Total I/O Points Consumed	Slot 1 I/O Address
F0-08SIM	8 Input	8 Input	X100 - X107
D0-10ND3	10 Input	16 Input (6 unused)	X100 - X107 and X110 - X111
D0-10ND3F	10 Input (fast)	16 Input (6 unused)	X100 - X107 and X110 - X111
D0-16ND3	16 Input	16 Input	X100 - X107 and X110 - X117
AC Input Modules	Physical I/O Points	Total I/O Points Consumed	Slot 1 I/O Address
F0-08NA-1	8 Input	8 Input*	X100 - X107
DC Output Modules	Physical I/O Points	Total I/O Points Consumed	Slot 1 I/O Address
D0-10TD1	10 Output	16 Output (6 unused)	Y100 - Y107 and Y110 - Y111
D0-16TD1	16 Output	16 Output	Y100 - Y107 and Y110 - Y117
D0-10TD2	10 Output	16 Output (6 unused)	Y100 - Y107 and Y110 - Y111
D0-16TD2	16 Output	16 Output	Y100 - Y107 and Y110 - Y117
Relay Output Modules	Physical I/O Points	Total I/O Points Consumed	Slot 1 I/O Address
D0-08TR	8 Output	8 Output*	Y100 - Y107
F0-04TRS	4 Output	8 Output (4 unused)*	Y100 - Y103
Combination Modules	Physical I/O Points	Total I/O Points Consumed	Slot 1 I/O Address
D0-07CDR	4 Input, 3 Output	8 Input (4 unused)*, 8 Output (5 unused)*	X100 - X103 and Y100 - Y102
D0-08CDD1	4 Input, 4 Output	8 Input (4 unused)*, 8 Output (4 unused)*	X100 - X103 and Y100 - Y103



NOTE: The information shown above is for Automatic I/O Configuration, which can assign addresses in groups as small as 8 I/O points. If manual I/O Configuration is used, the smallest allowable address group size is 16 I/O points. Therefore, each manually configured I/O module will consume at least 16 X (input) and/or 16 Y (output) addresses.

The diagrams on the next page show examples of the DL06 I/O addressing with various option modules installed.

All Discrete Modules Installed I/O Addressing Example:

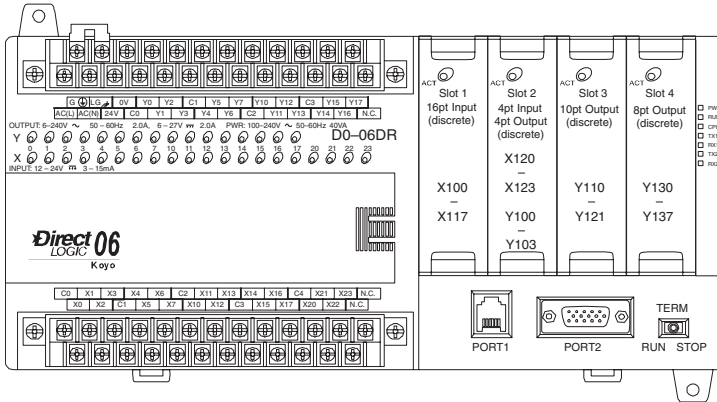

Discrete and Analog Modules Installed I/O Addressing Example:

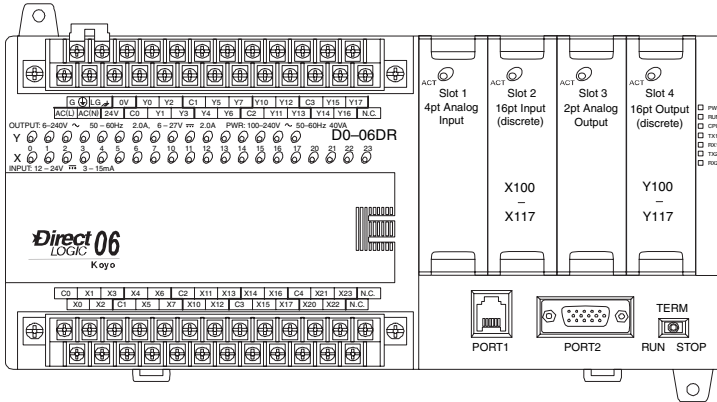

Discrete and Analog Modules Installed I/O Addressing Example:

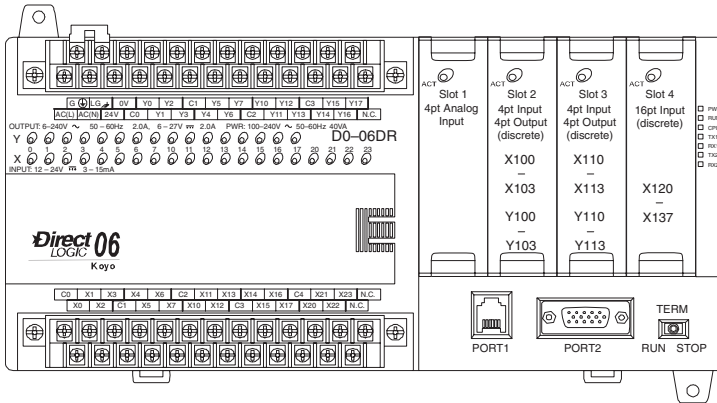

Discrete I/O General Specifications

The following is a list of general specifications for the discrete I/O option modules that are available for both the DL05 and DL06 PLCs. Also shown is information on the various removable connectors that are used for field wiring on the discrete I/O option modules along with reference to the *ZIPLink* connection system products that are available for the 16-point I/O modules.

General Specifications			
Operating Temperature	0 to 55 °C (32 to 131 °F)	Shock	MIL STD 810C 516.2
Storage Temperature	-20 to 70 °C (-4 to 158 °F)	Hi-pot	1500VAC, 1 min.
Humidity	5 to 95% (non-condensing)	Insulation Resistance	More than 10M ohms at 500VDC
Environmental Air	No Corrosive gases permitted	Noise Immunity	NEMA ICS3-304
Vibration	MIL STD 810C 514.2		

Discrete I/O Connector Specifications				
I/O Module	Connector	Wire Size	Screw Torque	Screwdriver Size
D0-10ND3	AutomationDirect replacement terminal kit p/n D0-ACC-4 or use Dinkle: EC350, 13-pin. *	22–16 AWG	0.39 N·m	TW-SD-VSL-1 (recommended)
D0-10ND3F	AutomationDirect replacement terminal kit p/n D0-ACC-4 or use Dinkle: EC350, 13-pin. *	22–16 AWG	0.39 N·m	TW-SD-VSL-1 (recommended)
D0-16ND3	<i>ZIPLink</i> ZL-CBL056 cable & ZL-CM056 conn. mod. or ZL-CBL056L cable & ZL-CM16L24 LED conn. mod. or build your own using a 24-pin Molex Micro Fit 3.0 receptacle, p/n 43025, or compatible.	(see <i>ZIPLink</i> specifications in AutomationDirect catalog under “Connection” tab.)		
F0-08NA-1	AutomationDirect replacement terminal kit p/n D0-ACC-4 or use Dinkle: EC350, 10-pin. *	22–16 AWG	0.39 N·m	TW-SD-VSL-1 (recommended)
D0-10TD1	AutomationDirect replacement terminal kit p/n D0-ACC-4 or use Dinkle: EC350, 13-pin. *	22–16 AWG	0.39 N·m	TW-SD-VSL-1 (recommended)
D0-16TD1	<i>ZIPLink</i> ZL-CBL056 cable & ZL-CM056 conn mod. or ZL-CBL056FR cable & ZL-CM16RL24B relay mod. or ZL-CM16TF2 fuse mod. or build your own using a 24-pin Molex Micro Fit 3.0 receptacle, p/n 43025, or compatible.	(see <i>ZIPLink</i> specifications in AutomationDirect catalog under “Connection” tab.)		
D0-10TD2	AutomationDirect replacement terminal kit p/n D0-ACC-4 or use Dinkle: EC350, 13-pin. *	22–16 AWG	0.39 N·m	TW-SD-VSL-1 (recommended)
D0-16TD2	<i>ZIPLink</i> ZL-CBL056 cable & ZL-CM056 conn. mod. or ZL-CBL056FR cable & ZL-CM16RL24B relay mod. or ZL-CM16TF2 fuse mod. or build your own using a 24-pin Molex Micro Fit 3.0 receptacle, p/n 43025, or compatible.	(see <i>ZIPLink</i> specifications in AutomationDirect catalog under “Connection” tab.)		
D0-07CDR	AutomationDirect replacement terminal kit p/n D0-ACC-4 or use Dinkle: EC350, 10-pin. *	22–16 AWG	0.39 N·m	TW-SD-VSL-1 (recommended)
D0-08TR	AutomationDirect replacement terminal kit p/n D0-ACC-4 or use Dinkle: EC350, 10-pin. *	22–16 AWG	0.39 N·m	TW-SD-VSL-1 (recommended)
D0-08CDD1	AutomationDirect replacement terminal kit p/n D0-ACC-4 or use Dinkle: EC350, 13-pin. *	22–16 AWG	0.39 N·m	TW-SD-VSL-1 (recommended)
F0-04TRS	AutomationDirect replacement terminal kit p/n D0-ACC-4 or use Dinkle: EC350, 13-pin. *	22–16 AWG	0.39 N·m	TW-SD-VSL-1 (recommended)

* I/O modules are supplied with connector; replacement terminal kit includes (2) 13-position & (2) 10-position terminal blocks.

Glossary of Specification Terms

Discrete Input

One of the input connections to the PLC which converts an electrical signal from a field device to a binary status (OFF or ON), which is read by the internal CPU each PLC scan.

Discrete Output

One of the output connections from the PLC which converts an internal ladder program result (0 or 1) to turn ON or OFF an output switching device. This enables the program to turn ON and OFF large field loads.

I/O Common

A connection in the input or output terminals which is shared by multiple I/O circuits. It usually is in the return path to the power supply of the I/O circuit.

Input Voltage Range

The operating voltage range of the input circuit.

Maximum Voltage

Maximum voltage allowed for the input circuit.

ON Voltage Level

The minimum voltage level at which the input point will turn ON.

OFF Voltage Level

The maximum voltage level at which the input point will turn OFF

Input Impedance

Input impedance can be used to calculate input current for a particular operating voltage.

Input Current

Typical operating current for an active (ON) input.

Minimum ON Current

The minimum current for the input circuit to operate reliably in the ON state.

Maximum OFF Current

The maximum current for the input circuit to operate reliably in the OFF state.

OFF to ON Response

The time the module requires to process an OFF to ON state transition.

ON to OFF Response

The time the module requires to process an ON to OFF state transition.

Status Indicators

The LEDs that indicate the ON/OFF status of an input or output point. All LEDs on the Micro PLCs are electrically located on the logic side of the input or output circuit.

F0-08SIM 8-Point Simulator Input Module

Input Specifications	
Number of Inputs	8
Status Indicators	None
Power Budget Requirements	1mA @ 5VDC (supplied by base)
Weight	45.36 g (1.6 oz.)

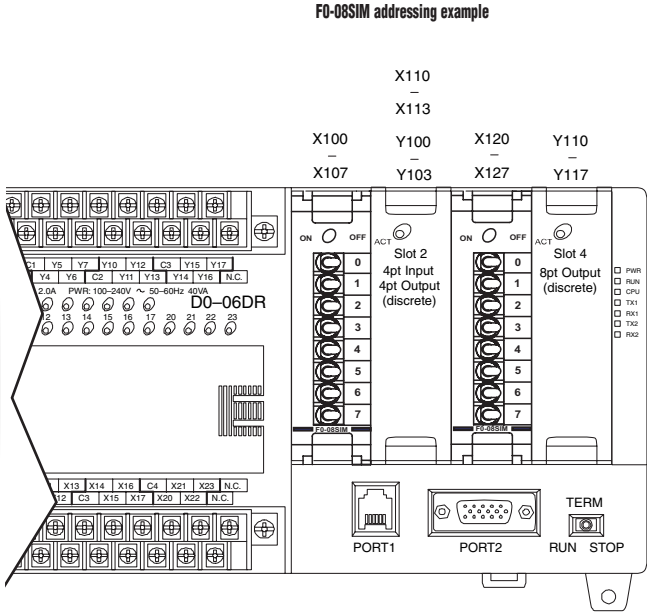
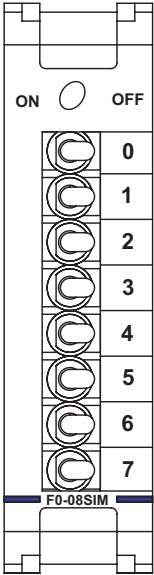

NOTE: The DL05 CPU's discrete feature for the F0-08SIM module requires DirectSOFT32 Version 3.0c (or later) and firmware version 4.90 (or later). The DL06 requires DirectSOFT32 version V4.0, build 16 (or later) and firmware version 1.80 (or later). See our website for more information: www.automationdirect.com.

D0-10ND3 10-Point DC Input Module

Input Specifications	
Number of Inputs	10 (sink/source)
Input Voltage Range	10.8–26.4 VDC
Operating Voltage Range	12–24 VDC
Peak Voltage	30.0 VDC
Input Current	Typical: 4.0 mA @ 12VDC 8.5 mA @ 24VDC
Maximum Input Current	11 mA @ 26.4 VDC
Input Impedance	2.8 kΩ @ 12–24 VDC
On Voltage Level	> 10.0 VDC
Off Voltage Level	< 2.0 VDC
Minimum ON Current	3.5 mA
Minimum OFF Current	0.5 mA
Off to On Response	2–8 ms, Typ. 4ms
On to Off Response	2–8 ms, Typ. 4ms
Status Indicators	Module activity: one green LED (See page 1-6)
Commons	2 (5 pts/common) Isolated
Fuse	No fuse
Power Budget Requirements	35mA @ 5VDC (supplied by base), (all pts ON)
Dimensions (mm)	19.8(W) x 76.8(H) x 53.9(D)
Weight	32g (1.13 oz.)

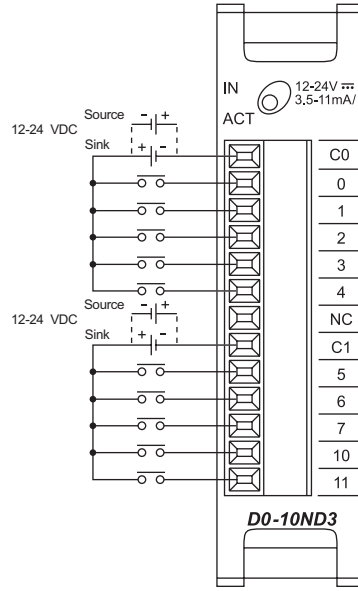

NOTE: The DL05 CPU's discrete feature for this module requires DirectSOFT32 Version 3.0c (or later) and firmware version 4.10 (or later). The DL06 requires DirectSOFT32 version V4.0, build 16 (or later) and firmware version 1.00 (or later). See our website for more information: www.automationdirect.com.

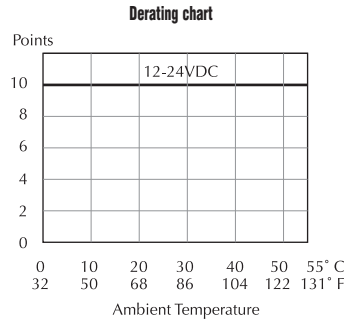
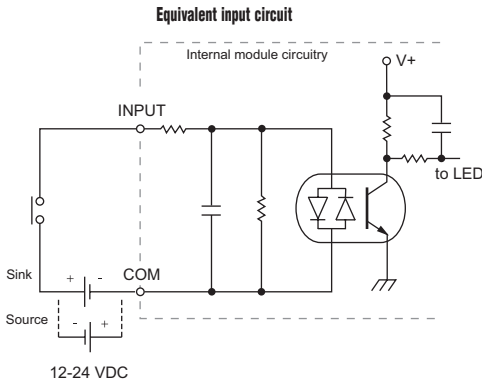

D0-10ND3F 10-Point DC Fast Input Module

Input Specifications	
Number of Inputs	10 (sink/source)
Input Voltage Range	10.8–26.4 VDC
Operating Voltage Range	12–24 VDC
Peak Voltage	30.0 VDC
Input Current	Typical: 4.0 mA @ 12VDC 8.5 mA @ 24VDC
Maximum Input Current	11 mA @ 26.4 VDC
Input Impedance	2.8 kΩ @ 12–24 VDC
On Voltage Level	> 10.0 VDC
Off Voltage Level	< 2.0 VDC
Minimum ON Current	3.5 mA
Minimum OFF Current	0.5 mA
Off to On Response	2ms, Typ. 1ms
On to Off Response	2ms, Typ. 1ms
Status Indicators	Module activity: one green LED (See page 1-6)
Commons	2 (5 pts/common) Isolated
Fuse	No fuse
Power Budget Requirements	35mA @ 5VDC (supplied by base), (all pts ON)
Dimensions (mm)	19.8(W) x 76.8(H) x 53.9(D)
Weight	32g (1.13 oz.)

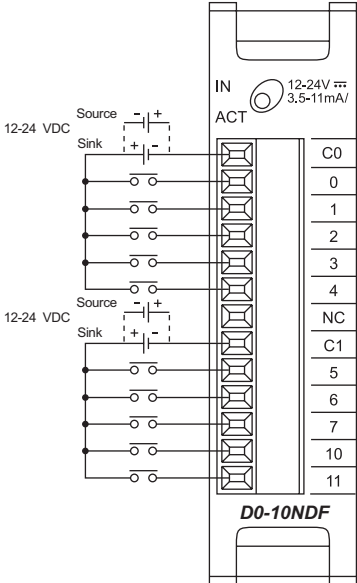

NOTE: The DL05 CPU's discrete feature for this module requires DirectSOFT32 Version 3.0c (or later) and firmware version 4.70 (or later). The DL06 requires DirectSOFT32 version V4.0, build 16 (or later) and firmware version 1.50 (or later). See our website for more information: www.automationdirect.com.

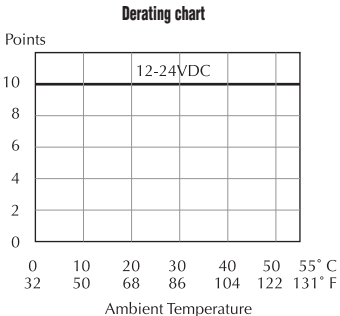
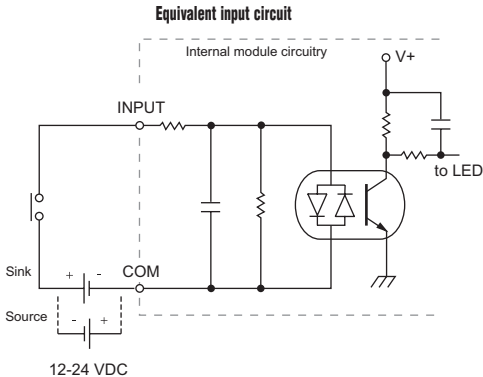

D0-16ND3 16-Point DC Input Module

Input Specifications	
Number of Inputs	16 (sink/source)
Input Voltage Range	20–28 VDC
Operating Voltage Range	24VDC
Peak Voltage	30.0 VDC
Input Current	Typical: 4.0 mA @ 24VDC 6mA @ 28VDC
Maximum Input Current	6mA @ 28VDC
Input Impedance	4.7 kΩ @ 24VDC
On Voltage Level	> 19.0 VDC
Off Voltage Level	< 7.0 VDC
Minimum ON Current	3.5 mA
Minimum OFF Current	1.5 mA
Off to on Response	2–8 ms, Typ. 4ms
On to off Response	2–8 ms, Typ. 4ms
Status Indicators	Module activity: one green LED (See page 1-6)
Commons	4 (4 pts/common) Isolated
Fuse	No fuse
Power Budget Requirements	35mA @ 5 VDC (supplied by base), (all pts ON)
Dimensions (mm)	19.8(W) x 76.8(H) x 53.9(D)
Weight	20g (0.71 oz.)

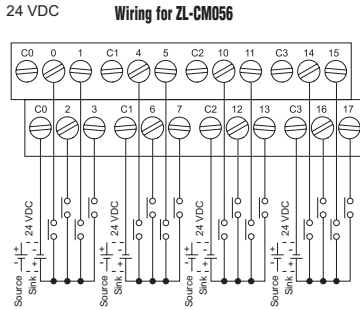
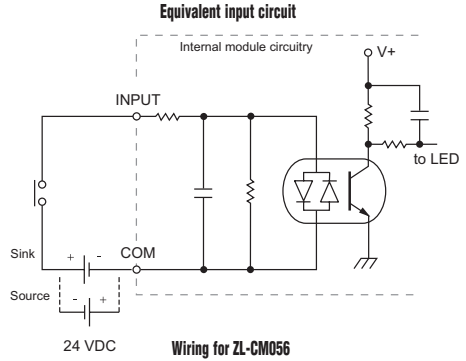
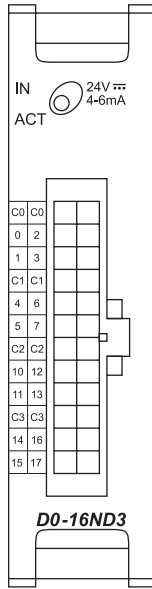

Derating chart

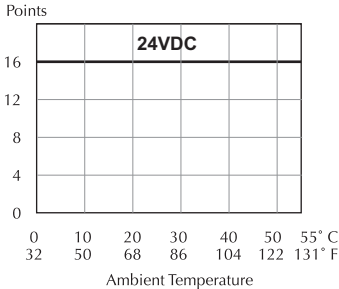

Use Z/PLink ZL-D0-CBL24L cable and ZL-RTB20 connector module, or ZL-D0-CBL24L cable and ZL-RR16-24-1 relay module or ZL-RFU203 fuse module. You can also build your own cables using 24-pin Molex Micro Fit 3.0 receptacle, part number 43025, or compatible.



NOTE: The DL05 CPU's discrete feature for this module requires DirectSOFT32 Version 3.0c (or later) and firmware version 4.10 (or later). The DL06 requires DirectSOFT32 version V4.0, build 16 (or later) and firmware version 1.00 (or later). See our website for more information: www.automationdirect.com.

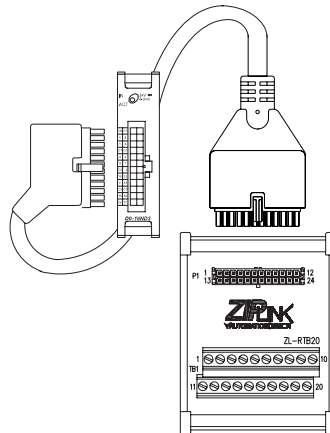

F0-08NA-1 8-Point AC Input Module

Input Specifications	
Number of Inputs	8
Input Voltage Range	80–132 VAC (90–150 VDC)
AC Frequency	47–63 Hz
Input Current	4.0 mA @ 132VAC
Input Impedance	33kΩ
On Voltage Level	80VAC minimum
Off Voltage Level	20VAC maximum
Minimum On Current	2.4 mA
Maximum Off Current	1.6 mA
Off to On Response	< 20ms
On to Off Response	< 10ms
Status Indicators	None
Commons	2 (4 pts/common) Isolated
Fuse	No fuse
Power Budget Requirements	5mA @ 5VDC (supplied by base), (all pts ON)
Dimensions (mm)	19.8(W) x 76.8(H) x 53.9(D)
Weight	31.2 g (1.1 oz.)

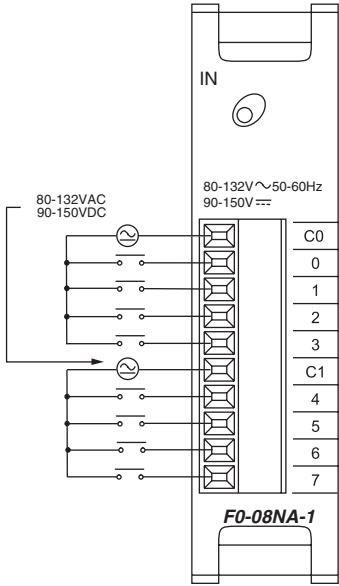

NOTE: The DL05 CPU's discrete feature for this module requires DirectSOFT32 Version 3.0c (or later) and firmware version 4.70 (or later). The DL06 requires DirectSOFT32 version V4.0, build 16 (or later) and firmware version 1.50 (or later). See our website for more information: www.automationdirect.com.

Equivalent input circuit

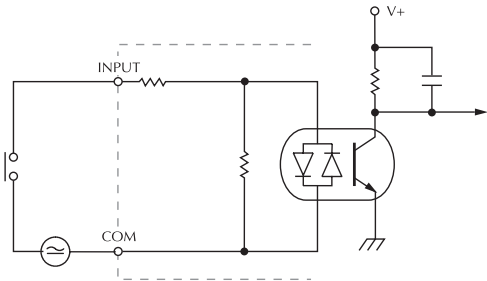

Derating chart

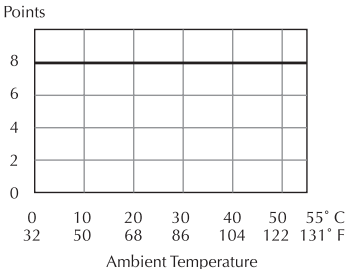

D0-10TD1 10-Point DC Output Module

Output Specifications	
Number of Outputs	10 (sinking)
Operating Voltage Range	6–27 VDC
Output Voltage Range	5–30 VDC
Peak Voltage	50.0 VDC
Maximum Output Current	0.3 A/point 1.5 A/common
Minimum Output Current	0.5 mA
ON Voltage Drop	0.5 VDC @ 0.3 A
Maximum Leakage Current	15µA @ 30.0 VDC
Maximum Inrush Current	1A for 10ms
OFF to ON Response	<10µs
ON to OFF Response	<60µs
Status Indicators	Module activity: one green LED (See page 1-6)
Commons	2 (5 points/common) Non-isolated
Fuse	No fuse
Power Budget Requirements	Max. 150mA @ 5VDC (supplied bybase), (all pts. ON)
External DC Power Required	20–28 VDC max. 200mA (all pts. ON)
Dimensions (mm)	19.8(W) x 76.8(H) x 53.9(D)
Weight	34g (1.20 oz.)

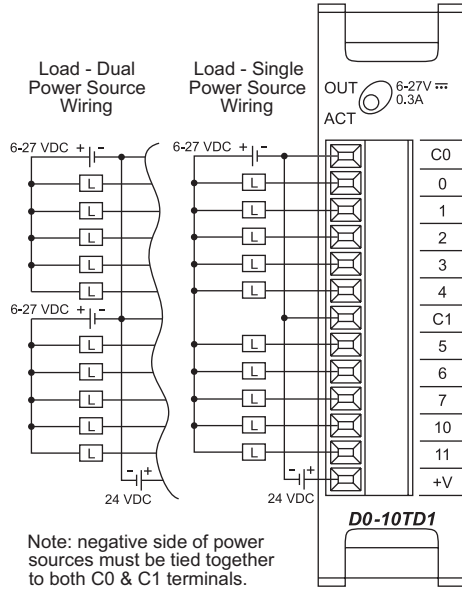

NOTE: The DL05 CPU's discrete feature for this module requires DirectSOFT32 Version 3.0c (or later) and firmware version 4.10 (or later). The DL06 requires DirectSOFT32 version V4.0, build 16 (or later) and firmware version 1.00 (or later). See our website for more information: www.automationdirect.com.

Equivalent output circuit

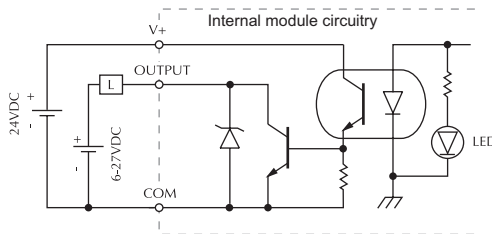

Derating chart

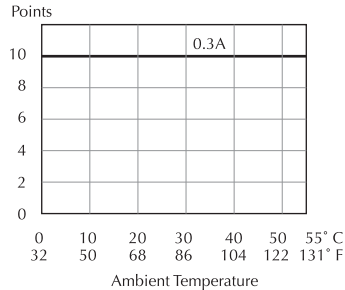

D0-16TD1 16-Point DC Output Module

Output Specifications	
Number of Outputs	16 (sinking)
Operating Voltage Range	6–27 VDC
Output Voltage Range	5–30 VDC
Peak Voltage	50.0 VDC
Maximum Output Current	0.1 A/point 0.8 A/common
Minimum Output Current	0.5 mA
ON Voltage Drop	0.5 VDC @ 0.1 A
Maximum Leakage Current	15µA @ 30.0 VDC
Maximum Inrush Current	1A for 10ms
OFF to ON Response	< 0.5 ms
ON to OFF Response	< 0.5 ms
Status Indicators	Module activity: one green LED (See page 1-6)
Commons	2 (8 points/common) Non-isolated
Fuse	No fuse
Power Budget Requirements	Max. 200mA @ 5VDC (supplied by base), (all pts. ON)
External DC Power Required	20–28 VDC max 70mA (all pts. ON)
Dimensions (mm)	19.8(W) x 76.8(H) x 53.9(D)
Weight	22g (0.78 oz.)

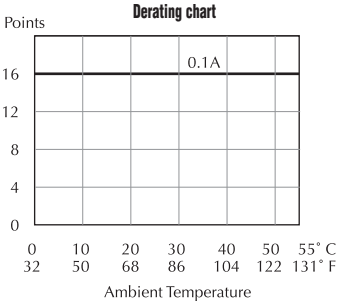
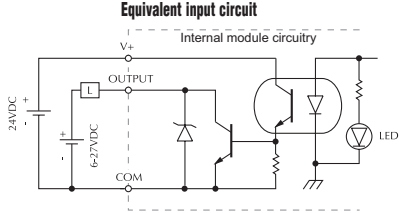
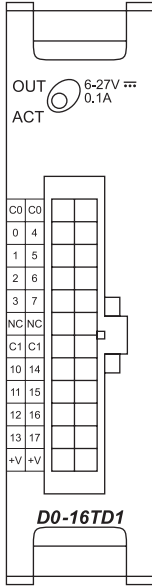

NOTE: The DL05 CPU's discrete feature for this module requires DirectSOFT32 Version 3.0c (or later) and firmware version 4.10 (or later). The DL06 requires DirectSOFT32 version V4.0, build 16 (or later) and firmware version 1.00 (or later). See our website for more information: www.automationdirect.com.

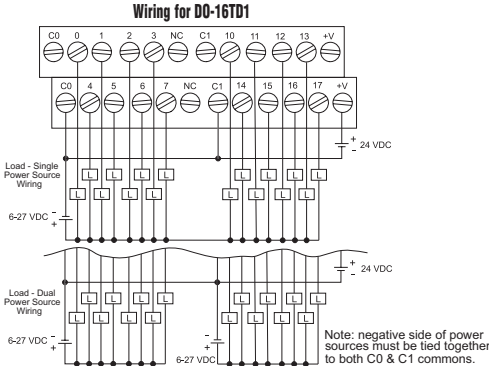

Use ZPLink ZL-DO-CBL24 cable and ZL-RTB20 connector module, or ZL-DO-CBL24 cable and ZL-RR16-24-1 relay module or ZL-RFU203 fuse module. You can also build your own cables using 24-pin Molex Micro Fit 3.0 receptacle, part number 43025, or compatible.

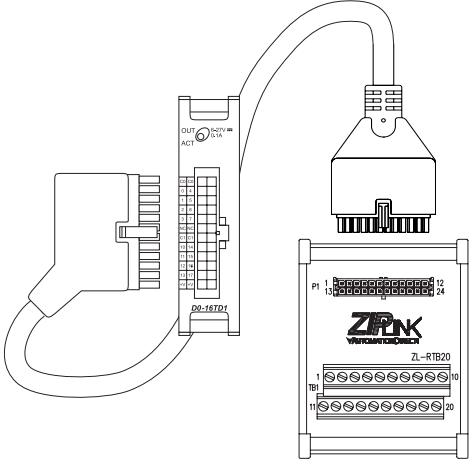

D0-10TD2 10-Point DC Output Module

Output Specifications	
Number of Outputs	10 (sourcing)
Operating Voltage Range	12–24 VDC
Output Voltage Range	10.8–26.4 VDC
Peak Voltage	50.0 VDC
Maximum Output Current	0.3 A/point 1.5 A/common
Minimum Output Current	0.5 mA
ON Voltage Drop	1.0 VDC @ 0.3 A
Maximum Leakage Current	1.5 μ A @ 30.0 VDC
Maximum Inrush Current	1A for 10ms
OFF to ON Response	<10 μ s
ON to OFF Response	<60 μ s
Status Indicators	Module activity: one green LED (See page 1-6)
+V Terminals & Common	2 (5 points/+V Terminal) Isolated, 1 Common
Fuse	No fuse
Power Budget Requirements	Max. 150mA @ 5VDC (supplied by base), (all pts. ON)
Dimensions (mm)	19.8(W) x 76.8(H) x 53.9(D)
Weight	38g (1.34 oz.)

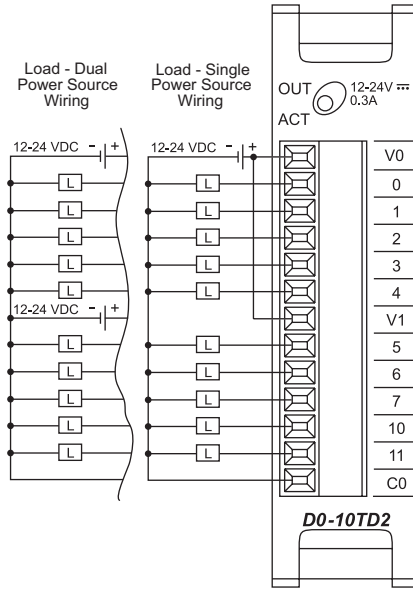

NOTE: The DL05 CPU's discrete feature for this module requires DirectSOFT32 Version 3.0c (or later) and firmware version 4.10 (or later). The DL06 requires DirectSOFT32 version V4.0, build 16 (or later) and firmware version 1.00 (or later). See our website for more information: www.automationdirect.com.

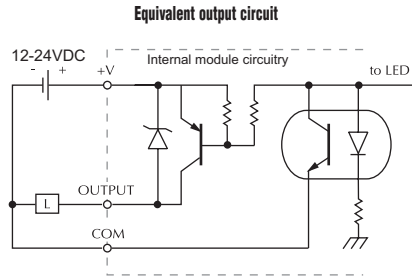
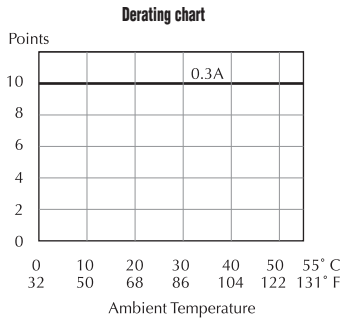

D0-16TD2 16-Point DC Output Module

Output Specifications	
Number of Outputs	16 (sourcing)
Operating Voltage Range	12–24 VDC
Output Voltage Range	10.8–26.4 VDC
Peak Voltage	50.0 VDC
Maximum Output Current	0.1 A/point, 0.8 A/common
Minimum Output Current	0.5 mA
ON Voltage Drop	1.0VDC @ 0.1 A
Maximum Leakage Current	1.5 µA @ 26.4 VDC
Maximum Inrush Current	1A for 10ms
OFF to ON Response	< 0.5 ms
ON to OFF Response	< 0.5 ms
Status Indicators	Module activity: one green LED (See page 1-6)
+V Terminals & Common	2 (8 points/+V Terminal) Isolated, 1 Common
Fuse	No fuse
Power Budget Requirements	Max. 200mA @ 5VDC (supplied bybase), (all pts. ON)
Dimensions (mm)	19.8(W) x 76.8(H) x 53.9(D)
Weight	22g (0.78 oz.)

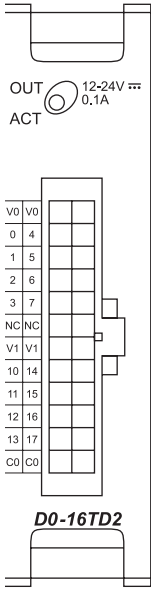

Equivalent output circuit

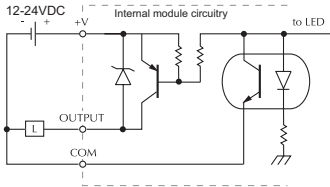

Derating chart

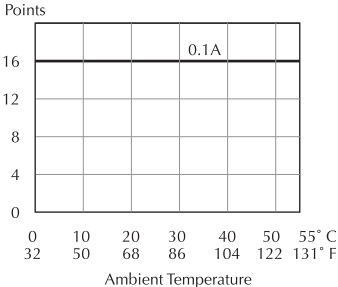

NOTE: The DL05 CPU's discrete feature for this module requires DirectSOFT32 Version 3.0c (or later) and firmware version 4.10 (or later). The DL06 requires DirectSOFT32 version V4.0, build 16 (or later) and firmware version 1.00 (or later). See our website for more information: www.automationdirect.com.

Wiring for ZL-RTB20

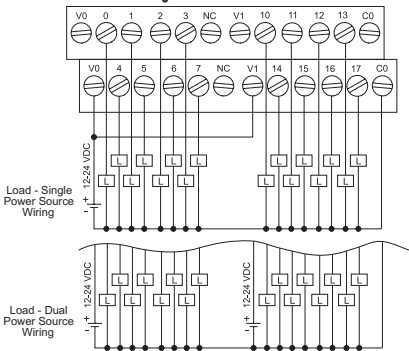

Use ZIPlink ZL-DO-CBL24 cable and ZL-RTB20 connector module, or ZL-DO-CBL24 cable and ZL-RR16-24-1 relay module or ZL-RFU203 fuse module. You can also build your own cables using 24-pin Molex Micro Fit 3.0 receptacle, part number 43025, or compatible.

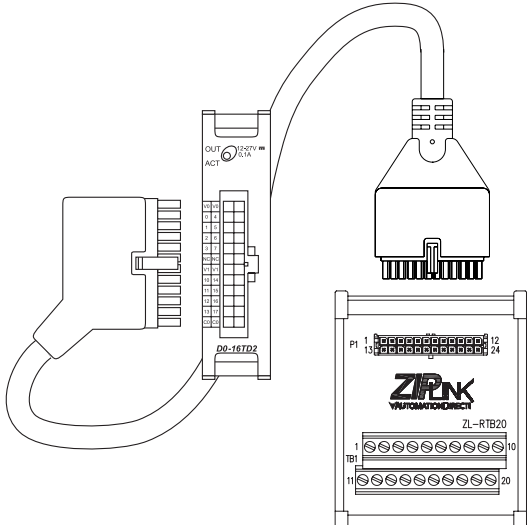

D0-07CDR 4-Point DC Input, 3-Point Relay Output Module

Input Specifications		Output Specifications	
Number of Inputs	4 (sink/source)	Number of Outputs	3
Operating Voltage Range	12–24 VDC	Operating Voltage Range	6–27 VDC/6–240 VAC
Input Voltage Range	10.8–26.4 VDC	Output Type	Relay, form A, SPST
Peak Voltage	30.0 VDC	Peak Voltage	30.0 VDC/ 264VAC
Maximum Input Current	11mA @ 26.4 VDC	Maximum Current (Resistive)	1A / point, 4A / common
Input Current	Typical: 4mA @ 12VDC 8.5 mA @ 24VDC	Minimum Load Current	5mA @ 5VDC
Input Impedance	2.8 kΩ @ 12–24 VDC	Maximum Leakage Current	0.1 mA @ 264VAC
ON Voltage Level	> 10.0 VDC	ON Voltage Drop	N/A
OFF Voltage Level	< 2.0 VDC	Maximum Inrush Current	Output: 3A for 10ms, Comm: 10A for 10ms
Minimum ON Current	3.5 mA	OFF to ON Response	<15ms
Maximum OFF Current	0.5 mA	ON to OFF Response	<10ms
OFF to ON Response	2–8 ms, typical 4ms	Status Indicators	Module activity: one green LED (See page 1-6)
ON to OFF Response	2–8 ms, typical 4ms	Commons	1 (3 points/common)
Commons	1 (4 points/common)	Fuse	No fuse
Power Budget Requirements	Max. 200mA @ 5VDC (supplied by base), (all pts. ON)	Dimensions (mm)	19.8(W) x 76.8(H) x 53.9(D)
		Weight	38g (1.34 oz.)



NOTE: The DL05 CPU's discrete feature for this module requires DirectSOFT32 Version 3.0c (or later) and firmware version 4.10 (or later). The DL06 requires DirectSOFT32 version V4.0, build 16 (or later) and firmware version 1.00 (or later). See our website for more information: www.automationdirect.com.

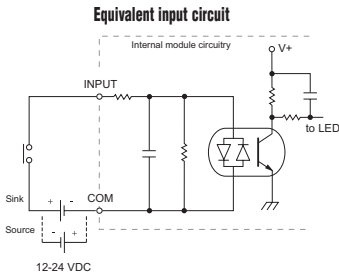

Derating chart for DC inputs

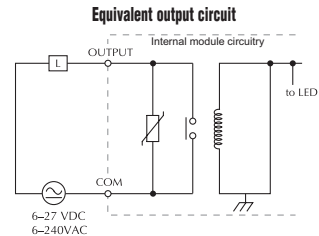
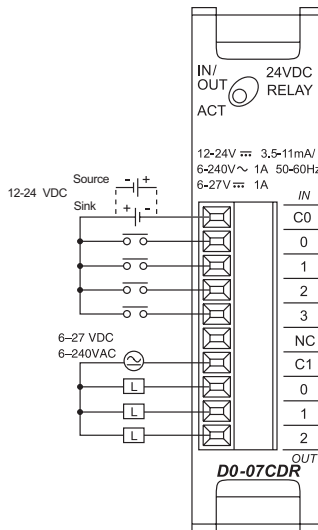
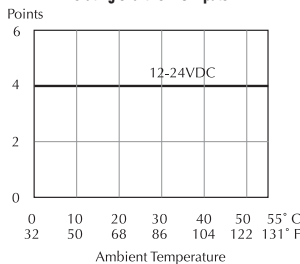

Derating chart for relay outputs

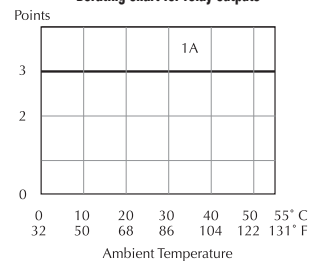

D0-08TR 8-Point Relay Output Module

Output Specifications	
Number of Outputs	8
Operating Voltage Range	6-27 VDC/6-240 VAC
Output Type	Relay, form A, SPST
Peak Voltage	30.0 VDC/ 264VAC
Maximum Current (Resistive)	1A/point, 4A/common
Minimum Load Current	0.5 mA
Maximum Leakage Current	0.1 mA @ 264VAC
ON Voltage Drop	N/A
Maximum Inrush Current	Output: 3A for 10ms, Common: 10A for 10ms
OFF to ON Response	<15ms
ON to OFF Response	<10ms
Status Indicators	Module activity: one green LED (See page 1-6)
Commons	2 Isolated. (4 points/common)
Fuse	No fuse
Power Budget Requirements	Max. 280mA @ 5VDC (supplied by base), (all pts. ON)
Dimensions (mm)	19.8(W) x 76.8(H) x 53.9(D)
Weight	55g (1.94 oz.)

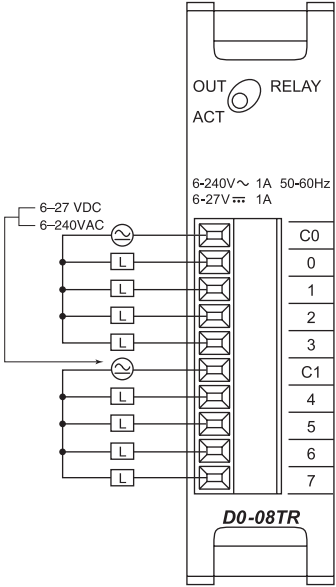

NOTE: The DL05 CPU's discrete feature for this module requires DirectSOFT32 Version 3.0c (or later) and firmware version 4.10 (or later). The DL06 requires DirectSOFT32 version V4.0, build 16 (or later) and firmware version 1.00 (or later). See our website for more information: www.automationdirect.com.

Equivalent output circuit

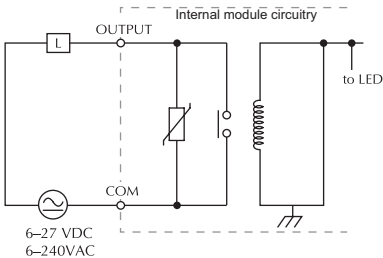

Derating chart

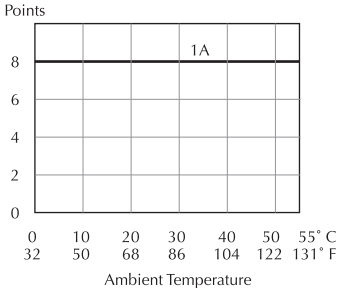

D0-08CDD1 4-Point DC Input, 4-Point DC Output Module

Input Specifications	
Number of Inputs	4 (sink/source)
Operating Voltage Range	10.8–26.4 VDC
Input Voltage Range	12–24 VDC
Peak Voltage	30.0 VDC
Maximum Input Current	11mA @ 26.4 VDC
Input Current	Typical: 4mA @ 12VDC 8.5 mA @ 24VDC
Input Impedance	2.8 k Ω @ 12–24VDC
ON Voltage Level	> 10.0 VDC
OFF Voltage Level	< 2.0 VDC
Minimum ON Current	3.5 mA
Maximum OFF Current	0.5 mA
OFF to ON Response	2–8 ms, typical 4ms
ON to OFF Response	2–8 ms, typical 4ms
Commons	2 Non-isolated
External DC Power Required	20–28 VDC, max. 80mA (all pts. ON)
Power Budget Requirements	Max. 200mA @ 5VDC (supplied bybase), (all pts. ON)

Output Specifications	
Number of Outputs	4 (sinking)
Operating Voltage Range	6–27 VDC
Output Voltage Range	5–30 VDC
Peak Voltage	50.0 VDC
Maximum Output Current	0.3 A/point, 1.2 A/common
Minimum Output Current	0.5 mA
Maximum Leakage Current	1.5 μ A @ 30.0 VDC
ON Voltage Drop	0.5 VDC @ 0.3 A
Maximum Inrush Current	1A for 10ms
OFF to ON Response	<10 μ s
ON to OFF Response	<60 μ s
Status indicators	Module activity: one green LED (See page 1-6)
Commons	2 Non-isolated
Fuse	No fuse
Dimensions (mm)	19.8(W) x 76.8(H) x 53.9(D)
Weight	34g (1.20 oz.)



NOTE: The DL05 CPU's discrete feature for this module requires DirectSOFT32 Version 3.0c (or later) and firmware version 4.10 (or later). The DL06 requires DirectSOFT32 version V4.0, build 16 (or later) and firmware version 1.00 (or later). See our website for more information: www.automationdirect.com.

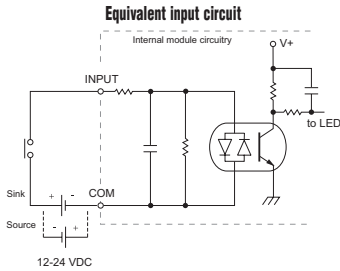

Input Derating Chart

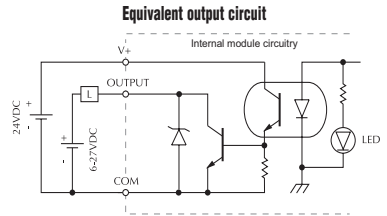
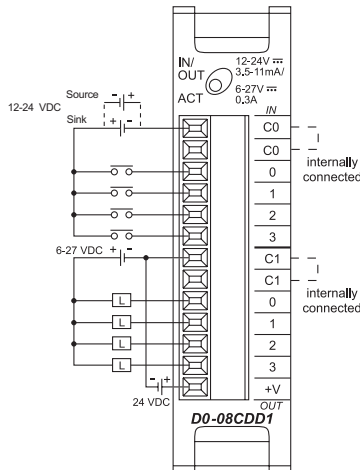
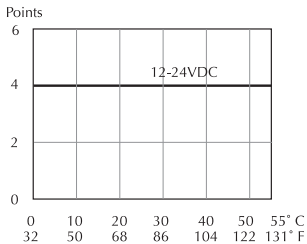

Output Derating chart

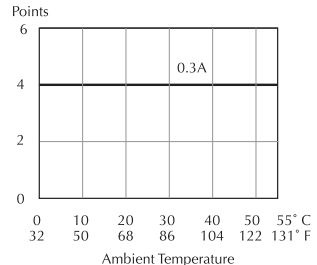

F0-04TRS 4-Point Relay Output Module

Output Specifications	
Number of Outputs	4
Operating Voltage Range	5–30 VDC/ 5–125 VAC
Output Type	2 - form C (SPDT) 2 - form A (SPST normally open)
Peak Voltage	60 VDC/ 220 VAC
AC Frequency	47–63 Hz
Maximum Current	3A per point, General Use
Minimum Load Current	10mA @ 5VDC
Maximum Leakage Current	N/A
ON Voltage Drop	N/A
Maximum Inrush Current	3A
OFF to ON Response	≤ 5ms (typical)
ON to OFF Response	≤ 5ms (typical)
Status Indicators	None
Commons	4 Isolated
Fuse	4, IEC 3.15 A, replaceable, D2-FUSE-1
Power Budget Requirements	Max. 250mA @ 5VDC (supplied by base), (all pts. ON)
Dimensions (mm)	19.8(W) x 76.8(H) x 53.9(D)
Weight	51g (1.8 oz.)

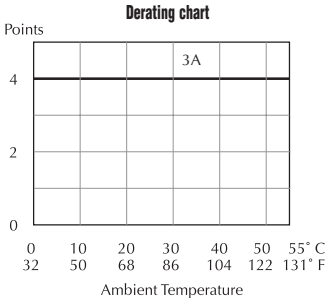
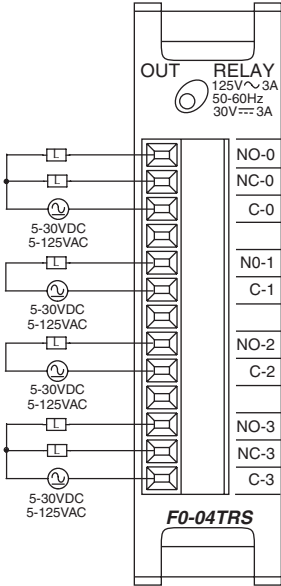

NOTE: The DL05 CPU's discrete feature for this module requires DirectSOFT32 Version 3.0c (or later) and firmware version 4.70 (or later). The DL06 requires DirectSOFT32 version V4.0, build 16 (or later) and firmware version 1.50 (or later). See our website for more information: www.automationdirect.com.

F0-04TRS Typical Relay Life at 30 Operations per Minute			
Load Type	Rated Voltage	Rated Current	Number of Operations
Resistive	120VAC	3A	120,000
Resistive	120VAC	1A	550,000
Resistive	24VDC	1A	>2M
Inductive: SC-E5 Motor Starter	120VAC	0.1 A operating 1.7 A fault	>2M (see Note)

Note: Transient suppression must be installed with inductive loads. (For example: P6KE150CA)

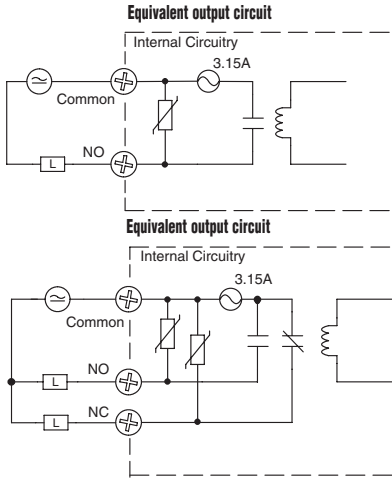

F0-04AD-1, 4-CHANNEL ANALOG CURRENT INPUT



In This Chapter...

Module Specifications	3-2
Setting the Module Jumper.....	3-4
Connecting and Disconnecting the Field Wiring	3-4
Wiring Diagram	3-5
Module Operation	3-6
Special V-memory Locations	3-7
Using the Pointer in Your Control Program	3-9
Detecting Input Signal Loss	3-11
Scale Conversions	3-11
Special Relays.....	3-13
Module Resolution.....	3-15
Analog Input Ladder Logic Filter	3-16

Module Specifications

The F0-04AD-1 Analog Input module offers the following features:

- The DL05 and DL06 will read all four channels in one scan.
- The removable terminal block makes it possible to remove the module without disconnecting the field wiring.
- Analog inputs can be used as process variables for the four (4) PID loops in the DL05 and the eight (8) PID loops in the DL06 CPUs.
- Field device burn-out is detected on all four channels when 4–20mA range is selected.
- On-board active analog filtering and RISC-like microcontroller provide digital signal processing to maintain precise analog measurements in noisy environments.

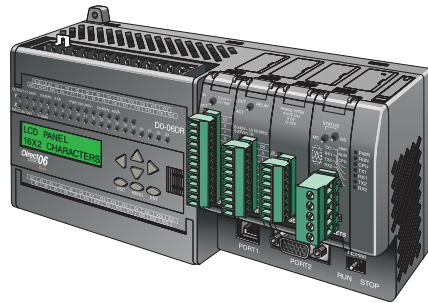

NOTE: The DL05 CPU's analog feature for this module requires **DirectSOFT32 Version 3.0c (or later)** and firmware version 2.10 (or later). The DL06 requires **DirectSOFT32 version V4.0, build 16 (or later)** and firmware version 1.00 (or later). See our website for more information: www.automationdirect.com.

The following tables provide the specifications for the F0-04AD-1 Analog Input Module. Review these specifications to make sure the module meets your application requirements.

Input Specifications	
Number of Channels	4, single ended (one common)
Input Range	0 to 20mA or 4 to 20mA current (jumper selectable)
Resolution	12 bit (1 in 4096) for 0–20 mA, scaled for 4–20 mA
Step Response	25.0 ms (typ) to 95% of full step change
Crosstalk	-80 dB, 1/2 count maximum *
Active Low-pass Filtering	-3dB at 40Hz (-12 dB per octave)
Input Impedance	125 Ohm \pm 0.1%, 1/8 W current input
Absolute Maximum Ratings	-30mA to +30mA current input
Converter type	Successive approximation
Linearity Error (End to End)	\pm 2 counts maximum *
Input Stability	\pm 1 count *
Full Scale Calibration Error (Offset error not included)	\pm 10 counts maximum, @ 20mA current input*
Offset Calibration Error	\pm 5 counts maximum @ 4mA current input *
Maximum Inaccuracy	\pm 0.4% @ 25°C (77°F) \pm 0.85% 0 to 60°C (32 to 140°F)
Accuracy vs. Temperature	\pm 100ppm /°C maximum full scale calibration (Including maximum offset change)
Recommended Fuse (external)	0.032 A Series 217 fast-acting current inputs

* One count in the specification table is equal to one least significant bit of the analog data value (1 in 4096).

General Specifications	
PLC Update Rate	4 channels per scan
16-bit Data Word	12 binary data bits
Operating Temperature	0 to 60° C (32 to 140°F)
Storage Temperature	-20 to 70°C (-4 to 158°F)
Relative Humidity	5 to 95% (non-condensing)
Environmental air	No corrosive gases permitted
Vibration	MIL STD 810C 514.2
Shock	MIL STD 810C 516.2
Noise Immunity	NEMA ICS3-304
Power Budget Requirement	50mA @ 5VDC (supplied by base)
Connector	Phoenix Mecano, Inc. Part No. AK1550/8-3.5 - green
Connector Wire Size	28–16 AWG
Connector Screw Torque	0.4 N·m
Connector Screwdriver Size	DN-SS1 (recommended)

Setting the Module Jumper

The position of jumper J3 determines the input signal level. You can choose between 4–20 mA and 0–20 mA. The module ships with the jumper not connecting the two pins. In this position, the expected input signal is 4–20 mA. To select 0–20 mA signals, use the jumper to cover both pins.

The default jumper setting selects a 4–20 mA signal source. The default jumper setting does not connect the two pins.

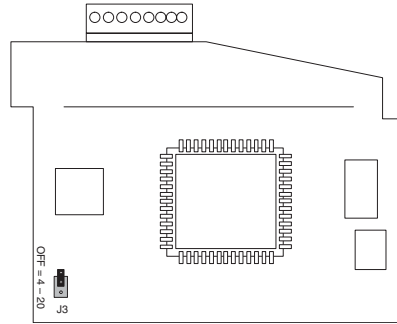

WARNING: Before removing the analog module or the terminal block on the face of the module, disconnect power to the PLC and all field devices. Failure to disconnect power can result in damage to the PLC and/or field devices.

Connecting and Disconnecting the Field Wiring

Wiring Guidelines

Your company may have guidelines for wiring and cable installation. If so, you should check those before you begin the installation. Here are some general things to consider:

- Use the shortest wiring route whenever possible.
- Use shielded wiring and ground the shield at the transmitter source. *Do not* ground the shield at both the module and the source.
- Do not run the signal wiring next to large motors, high current switches, or transformers. This may cause noise problems.
- Route the wiring through an approved cable housing to minimize the risk of accidental damage. Check local and national codes to choose the correct method for your application.

The F0-04AD-1 does not supply power to field devices. You will need to power transmitters separately from the PLC.

To remove the terminal block, disconnect power to the PLC and the field devices. Pull the terminal block firmly until the connector separates from the module.

You can remove the analog module from the PLC by folding out the retaining tabs at the top and bottom of the module. As the retaining tabs pivot upward and outward, the module's connector is lifted out of the PLC socket. Once the connector is free, you can lift the module out of its slot.

Wiring Diagram

Use the following diagram to connect the field wiring. If necessary, the F0-04AD-1 terminal block can be removed to make removal of the module possible without disturbing field wiring.

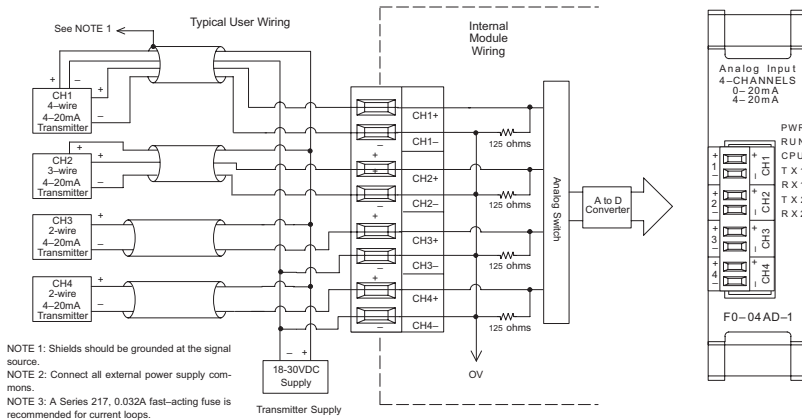

Transmitter Impedance

Manufacturers of transmitters and transducers specify a wide variety of power sources for their products. Follow the manufacturer's recommendations.

In some cases, manufacturers specify a minimum loop or load resistance that must be used with the transmitter. The F0-04AD-1 provides 125 ohm resistance for each channel. If your transmitter requires a load resistance below 125 ohms, you do not have to make any changes. However, if your transmitter requires a load resistance higher than 125 ohms, you need to add a resistor in series with the module.

Consider the following example for a transmitter being operated from a 30 VDC supply with a recommended load resistance of 750 ohms. Since the module has a 125 ohm resistor, you need to add an additional resistor.

$$R = Tr - Mr$$

$$R = 750 - 125$$

$$R \geq 625$$

R = resistor to add
 Tr = Transmitter Requirement
 Mr = Module resistance (internal 125 ohms)

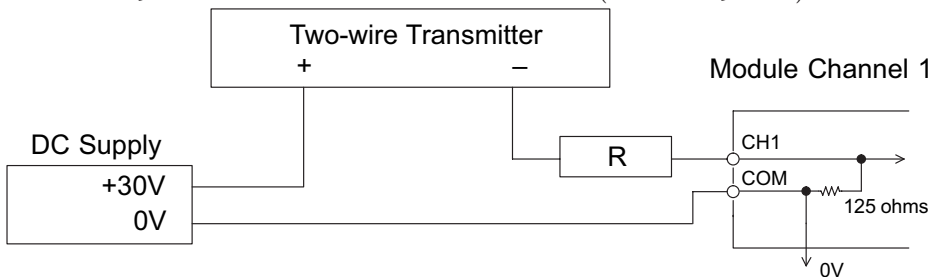

Module Operation

Channel Scanning Sequence

The DL05 and DL06 will read all four channels of input data during each scan. Each CPU supports special V-memory locations that are used to manage the data transfer. This is discussed in more detail beginning in the section on “Special V-memory Locations”.

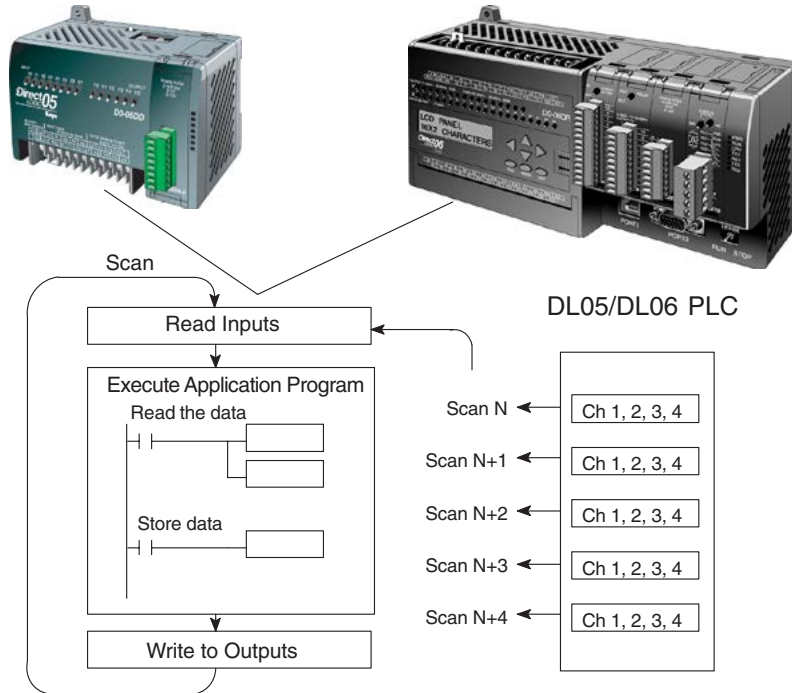

Analog Module Updates

Even though the channel updates to the CPUs are synchronous with the CPU scan, the module asynchronously monitors the analog transmitter signals and converts each signal into a 12-bit binary representation. This enables the module to continuously provide accurate measurements without slowing down the discrete control logic in the RLL program.

The module takes approximately 25 milliseconds to sense 95% of the change in the analog signal. For the vast majority of applications, the process changes are much slower than these updates.



NOTE: If you are comparing other manufacturers' update times (step responses) with ours, please be aware that some manufacturers refer to the time it takes to convert the analog signal to a digital value. Our analog to digital conversion takes only a few microseconds. It is the settling time of the filter that is critical in determining the full update time. Our update time specification includes the filter settling time.

Special V-memory Locations

Formatting the Module Data

The DL05 and DL06 PLCs have special V-memory locations assigned to their respective option slots. These V-memory locations allow you to:

- Specify the data format (binary or BCD)
- Specify the number of channels to scan (4 channels for the F0-04AD-1)
- Specify the V-memory locations to store the input data

DL05 Data Formatting

The table below shows the special V-memory locations used by the DL05 PLC for the F0-04AD-1.

Analog Input Module DL05 Special V-memory Locations	
Data Type and Number of Channels	V7700
Storage Pointer	V7701

Structure of V7700

Special V-memory location 7700 indicates that a F0-04AD-1 module is installed in the DL05 option slot and the data type to be either binary or BCD.

Loading a constant of 400 into V7700 identifies a 4-channel analog input module is installed in the DL05 option slot, and reads the input data values as BCD numbers.

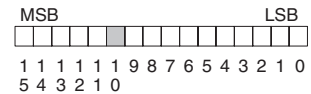

Loading a constant of 8400 into V7700 identifies a 4-channel analog input module is installed in the DL05 option slot, and reads the input data values as binary numbers.

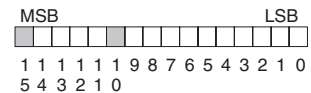

Structure of V7701

V7701 is a system V-memory location used as a pointer to a user V-memory location where the analog input data is stored. The V-memory location loaded into V7701 is an octal number identifying the first user V-memory location for reading the analog input data. This V-memory location is user selectable. For example, loading O2000 causes the pointer to write Ch 1's data value to V2000, Ch 2's data value to V2001, Ch 3's data value to V2002, and Ch 4's data value to V2003.

You will find an example program that loads appropriate values to V7700 and V7701 on page 3-9.

DL06 Data Formatting

Special V-memory locations are assigned to the four option slots of the DL06 PLC. The table below shows these V-memory locations which can be used to setup the F0-04AD-1.

Analog Input Module DL06 Special V-memory Locations				
Slot No.	1	2	3	4
Data Type and Number of Channels	V700	V710	V720	V730
Storage Pointer	V701	V711	V721	V731

Setup Data Type and Number of Channels

V-memory locations 700, 710, 720 and 730 are used to set the data format to be read in either binary or BCD, and to set the number of channels that will be active.

For example, the F0-04AD-1 is installed in slot 1. Loading a constant of 400 into V700 sets 4 channels active, and the input data value is read as a BCD number.

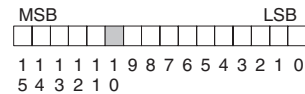

With the F0-04AD-1 in slot 1, loading a constant of 8400 into V700 sets 4 channels active, and the input data value is read as a binary number.

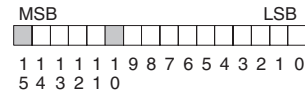

Storage Pointer Setup

V-memory locations 701, 711, 721 and 731 are special locations used as storage pointers. A V-memory address is loaded into this location as an octal number identifying the first user V-memory location for the analog input data. This V-memory location is user selectable. For example, loading O2000 causes the pointer to write Ch 1's data value to V2000, Ch 2's data value to V2001, Ch 3's data value to V2002, and Ch 4's data value to V2003.

You will find an example program that loads appropriate values to V700 and V701 beginning on page 3-10.

Using the Pointer in Your Control Program

DL05 Pointer Method

The DL05 CPU examines the pointer values (the memory locations identified in V7700 and V7701) on the first scan only.

The example program below shows how to setup these locations. This rung can be placed anywhere in the ladder program or in the initial stage if you are using stage programming instructions.

This is all that is required to read the analog input data into V-memory locations. Once the data is in V-memory you can perform math on the data, compare the data against preset values, and so forth. V2000 is used in the example but you can use any user V-memory location.

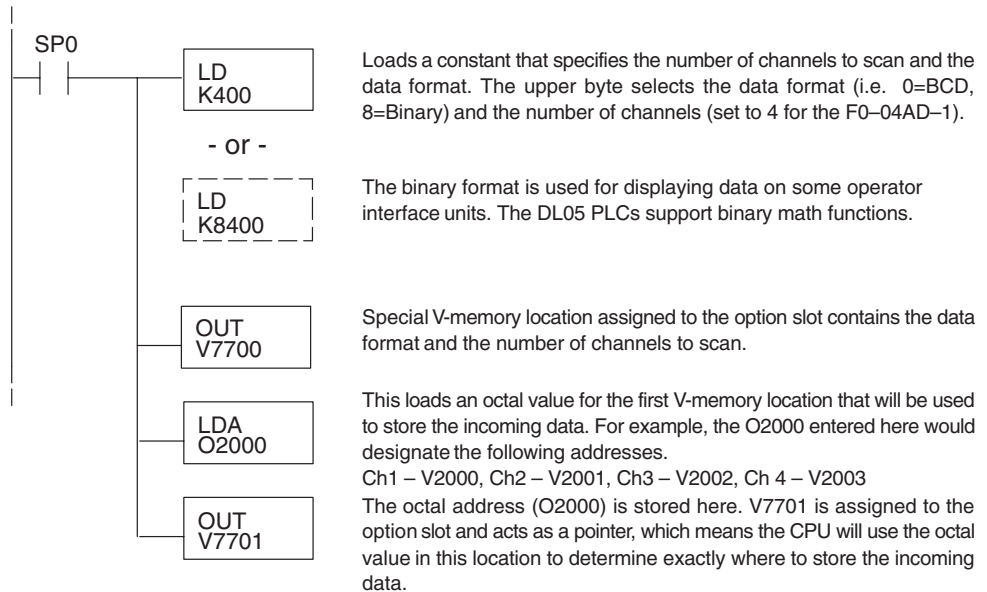

DL06 Pointer Method

Use the special V-memory table below as a guide to setup the storage pointer in the following example for the DL06. Slot 1 is the left most option slot. The CPU will examine the pointer values at these locations only after a mode transition.

Analog Input Module DL06 Special V-memory Locations				
Slot No.	1	2	3	4
No. of Channels	V700	V710	V720	V730
Input Pointer	V701	V711	V721	V731

The F0-04AD-1 can be installed in any available DL06 option slot. Using the example program from the previous page, but changing the V-memory addresses, the ladder diagram below shows how to setup these locations with the module installed in slot 1 of the DL06. Use the above table to determine the pointer values if locating the module in any of the other slot locations. Place this rung anywhere in the ladder program or in the initial stage if you are using stage programming instructions.

Like the DL05 example, this logic is all that is required to read the analog input data into V-memory locations. Once the data is in V-memory you can perform mathematical calculations with the data, compare the data against preset values, and so forth. V2000 is used in the example but you can use any user V-memory location.

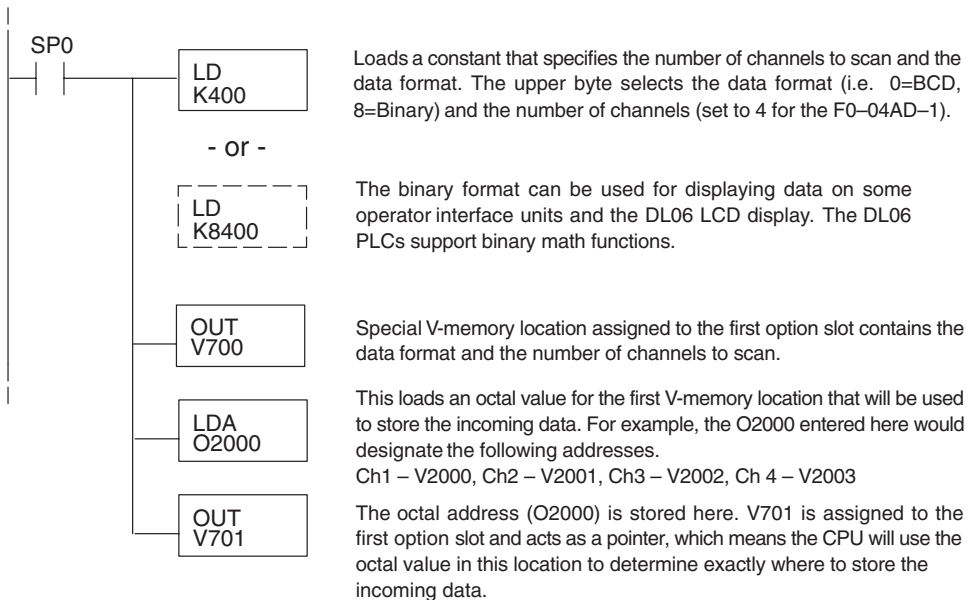

Detecting Input Signal Loss

Analog Signal Loss

The F0-04AD-1 analog module can sense the loss of analog input signals in 4–20 mA loops. The Special Relays described on page 3–14 allow you to use this feature in your ladder program. For example, in the rung below SP610 is used to pull-in coil Y1, which would be used to open or close an external circuit.



The Special Relay SP610 detects a loss of input signal to channel 1. Use SP610 to trigger an alarm or shut down a machine.



NOTE: The F0-04AD-1 analog module cannot sense the loss of analog input signals in 0–20 mA loops. See page 3–4 for information about setting the jumper to select your input type.

Scale Conversions

Scaling the Input Data

Many applications call for measurements in engineering units, which can be more meaningful than raw data. Convert to engineering units using the formula shown to the right.

You may have to make adjustments to the formula depending on the scale you choose for the engineering units.

For example, if you wanted to measure pressure (PSI) from 0.0 to 99.9 then you would have to multiply the analog value by 10 in order to imply a decimal place when you view the value with the programming software or a handheld programmer. Notice how the calculations differ when you use the multiplier.

Analog Value of 2024, slightly less than half scale, should yield 49.4 PSI

$$\text{Units} = A \frac{H-L}{4095} + L$$

H = High limit of the engineering unit range

L = Low limit of the engineering unit range

A = Analog value (0 – 4095)

Example without multiplier

$$\text{Units} = A \frac{H-L}{4095} + L$$

$$\text{Units} = 2024 \frac{100-0}{4095} + 0$$

$$\text{Units} = 49$$

Example with multiplier

$$\text{Units} = 10 A \frac{H-L}{4095} + L$$

$$\text{Units} = 20240 \frac{100-0}{4095} + 0$$

$$\text{Units} = 494$$

The Conversion Program

The following example shows how you would write the program to perform the engineering unit conversion. This example assumes you have BCD data loaded into the appropriate V-memory locations using instructions that apply for the model of CPU you are using.

Note: this example uses SP1, which is always on. You could also use an X, C, etc. permissive contact.

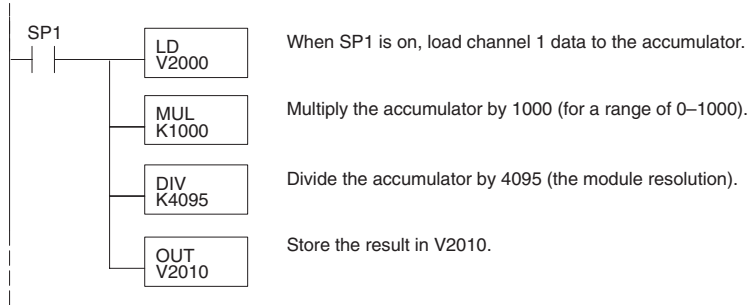

Analog and Digital Value Conversions

Sometimes it is useful to convert between the signal levels and the digital values. This is especially helpful during machine startup or troubleshooting. The following table provides formulas to make this conversion easier.

Range	If you know the digital value	If you know the analog signal level
4 to 20mA	$A = \frac{16D}{4095} + 4$	$D = \frac{4095}{16} \cdot (A - 4)$
0 to 20mA	$A = \frac{20D}{4095}$	$D = \frac{4095}{20} \cdot A$

For example, if you have measured the signal as 10mA, use the formula to determine the digital value that will be stored in memory location that contains the data.

$$D = \frac{4095}{20} \cdot A$$

$$D = \frac{4095}{20} \cdot 10\text{mA}$$

$$D = 2048$$

Special Relays

The list of other Special Relays associated with the DL05 and DL06 PLCs are contained in the DL05 User Manual and the DL06 User Manual. The following special relays are new and relate to the status of the F0-04AD-1 module or one of its input channels.

DL05 Special Relays

DL05 Special Relays			
SP600	Chan 1 input type	0 = 0-20mA	1 = 4-20mA
SP601	Chan 2 input type	0 = 0-20mA	1 = 4-20mA
SP602	Chan 3 input type	0 = 0-20mA	1 = 4-20mA
SP603	Chan 4 input type	0 = 0-20mA	1 = 4-20mA
SP610	Chan 1 input open	1 = xmitter signal open	0 = xmitter signal good
SP611	Chan 2 input open	1 = xmitter signal open	0 = xmitter signal good
SP612	Chan 3 input open	1 = xmitter signal open	0 = xmitter signal good
SP613	Chan 4 input open	1 = xmitter signal open	0 = xmitter signal good

DL06 Special Relays

DL06 Special Relays			
SLOT 1			
SP140	Chan 1 input type	0 = 0-20mA	1 = 4-20mA
SP141	Chan 2 input type	0 = 0-20mA	1 = 4-20mA
SP142	Chan 3 input type	0 = 0-20mA	1 = 4-20mA
SP143	Chan 4 input type	0 = 0-20mA	1 = 4-20mA
SP150	Chan 1 input open	1 = xmitter signal open	0 = xmitter signal good
SP151	Chan 2 input open	1 = xmitter signal open	0 = xmitter signal good
SP152	Chan 3 input open	1 = xmitter signal open	0 = xmitter signal good
SP153	Chan 4 input open	1 = xmitter signal open	0 = xmitter signal good

SLOT 2			
SP240	Chan 1 input type	0 = 0-20mA	1 = 4-20mA
SP241	Chan 2 input type	0 = 0-20mA	1 = 4-20mA
SP242	Chan 3 input type	0 = 0-20mA	1 = 4-20mA
SP243	Chan 4 input type	0 = 0-20mA	1 = 4-20mA
SP250	Chan 1 input open	1 = xmitter signal open	0 = xmitter signal good
SP251	Chan 2 input open	1 = xmitter signal open	0 = xmitter signal good
SP252	Chan 3 input open	1 = xmitter signal open	0 = xmitter signal good
SP253	Chan 4 input open	1 = xmitter signal open	0 = xmitter signal good

DL06 Special Relays (cont'd)			
SLOT 3			
SP340	Chan 1 input type	0 = 0–20 mA	1 = 4–20 mA
SP341	Chan 2 input type	0 = 0–20 mA	1 = 4–20 mA
SP342	Chan 3 input type	0 = 0–20 mA	1 = 4–20 mA
SP343	Chan 4 input type	0 = 0–20 mA	1 = 4–20 mA
SP350	Chan 1 input open	1 = xmitter signal open	0 = xmitter signal good
SP351	Chan 2 input open	1 = xmitter signal open	0 = xmitter signal good
SP352	Chan 3 input open	1 = xmitter signal open	0 = xmitter signal good
SP353	Chan 4 input open	1 = xmitter signal open	0 = xmitter signal good

SLOT 4			
SP440	Chan 1 input type	0 = 0–20 mA	1 = 4–20 mA
SP441	Chan 2 input type	0 = 0–20 mA	1 = 4–20 mA
SP442	Chan 3 input type	0 = 0–20 mA	1 = 4–20 mA
SP443	Chan 4 input type	0 = 0–20 mA	1 = 4–20 mA
SP450	Chan 1 input open	1 = xmitter signal open	0 = xmitter signal good
SP451	Chan 2 input open	1 = xmitter signal open	0 = xmitter signal good
SP452	Chan 3 input open	1 = xmitter signal open	0 = xmitter signal good
SP453	Chan 4 input open	1 = xmitter signal open	0 = xmitter signal good

Module Resolution

Analog Data Bits

The first twelve bits represent the analog data in binary format.

Bit	Value	Bit	Value
0	1	6	64
1	2	7	128
2	4	8	256
3	8	9	512
4	16	10	1024
5	32	11	2048

MSB												LSB											
[] [] [] [] [] [] [] [] [] [] [] []												[] [] [] [] [] [] [] [] [] [] [] []											
												1 1 9 8 7 6 5 4 3 2 1 0											
												1 0											

[] = data bits

Resolution Details

Since the module has 12-bit resolution, the analog signal is converted into 4096 counts ranging from 0–4095 (2^{12}). For example, a 4mA signal would be 0 and a 20mA signal would be 4095. This is equivalent to a binary value of 0000 0000 0000 to 1111 1111 1111, or 000 to FFF hexadecimal.

Each count can also be expressed in terms of the signal level by using the following equation:

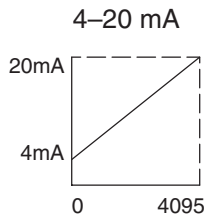

$$\text{Resolution} = \frac{H - L}{4095}$$

H = high limit of the signal range

L = low limit of the signal range

mA Range	Signal Span (H - L)	Divide By	Smallest Detectable Change
4 to 20 mA	16mA	4095	3.907 μ A
0 to 20 mA	20mA	4095	4.884 μ A

Analog Input Ladder Logic Filter

PID Loops / Filtering:

Please refer to the “PID Loop Operation” chapter in the DL06 or DL05 User Manual for information on the built-in PV filter (DL05/06) and the ladder logic filter (DL06 only) shown below. A filter must be used to smooth the analog input value when auto tuning PID loops to prevent giving a false indication of loop characteristics.

Smoothing the Input Signal (DL06 only):

The filter logic can also be used in the same way to smooth the analog input signal to help stabilize PID loop operation or to stabilize the analog input signal value for use with an operator interface display, etc.



WARNING: The built-in and logic filters are not intended to smooth or filter noise generated by improper field device wiring or grounding. Small amounts of electrical noise can cause the input signal to bounce considerably. Proper field device wiring and grounding must be done before attempting to use the filters to smooth the analog input signal.

Using Binary Data Format

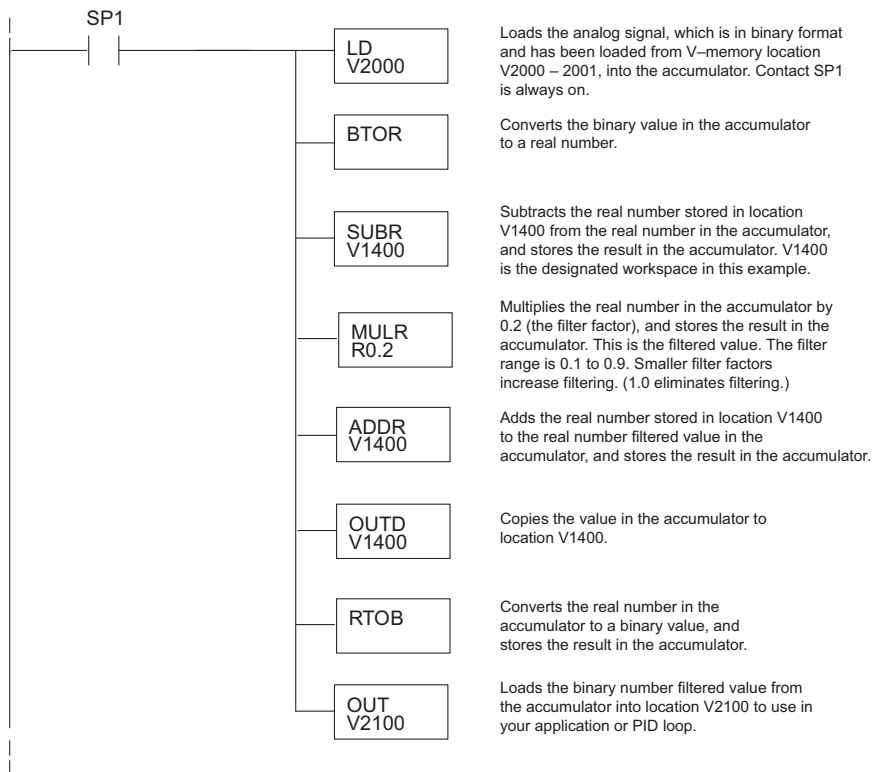



NOTE: Be careful not to do a multiple number conversion on a value. For example, if you are using the pointer method in BCD format to get the analog value, it must be converted to binary (BIN) as shown below. If you are using the pointer method in Binary format, the conversion to binary (BIN) instruction is not needed.

Using BCD Data Format

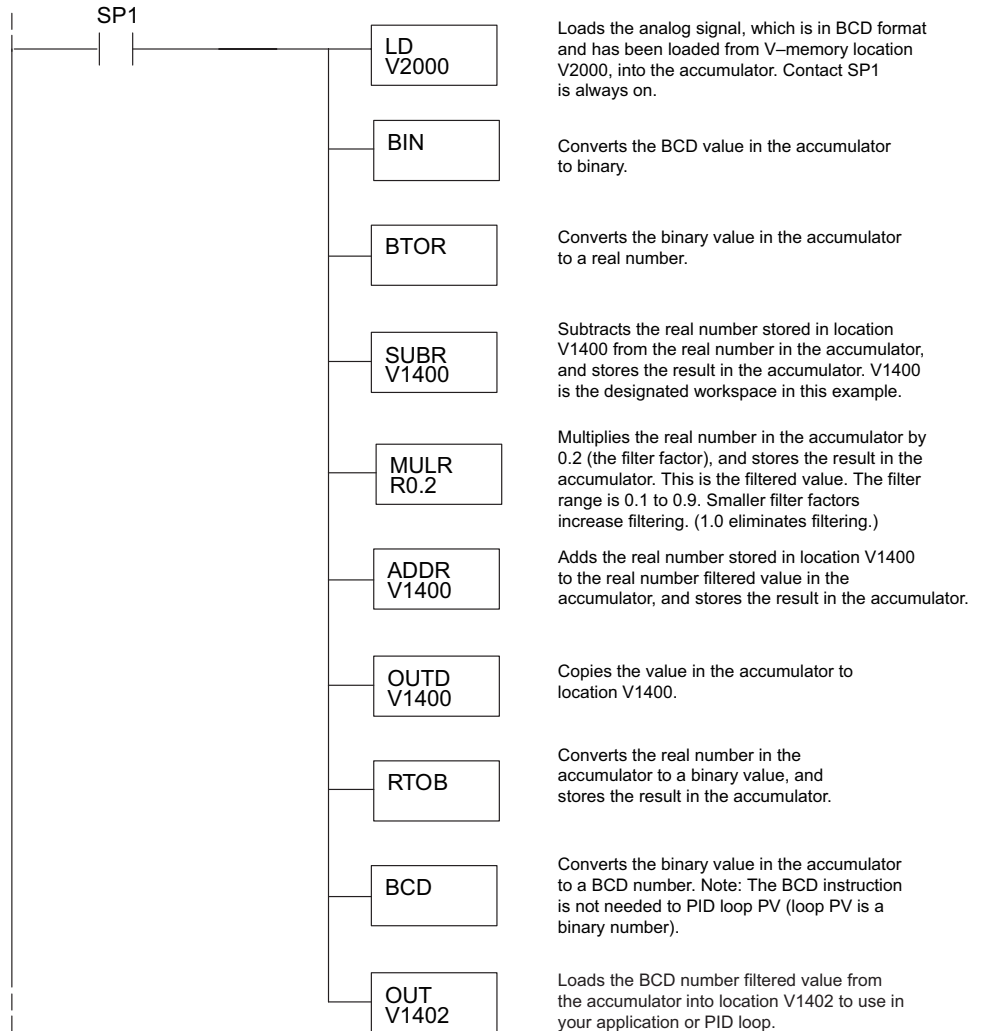

F0-08ADH-1, 8-CHANNEL ANALOG CURRENT INPUT



In This Chapter...

Module Specifications	4-2
Connecting and Disconnecting the Field Wiring	4-4
Wiring Diagram	4-5
Module Operation	4-6
Special V-memory Locations	4-7
Using the Pointer in Your Control Program	4-9
Scale Conversions	4-11
Module Resolution.....	4-14
Analog Input Ladder Logic Filter	4-15

Module Specifications

The F0-08ADH-1 Analog Input module offers the following features:

- The DL05 and DL06 will read all eight channels in one scan.
- The removable terminal block simplifies module replacement.
- Analog inputs can be used as process variables for the four (4) PID loops in the DL05 and the eight (8) PID loops in the DL06 CPUs.
- On-board active analog filtering and RISC-like microcontroller provide digital signal processing to maintain precise analog measurements in noisy environments.
- These modules are isolated from the PLC power supply logic side (1800 Volt).

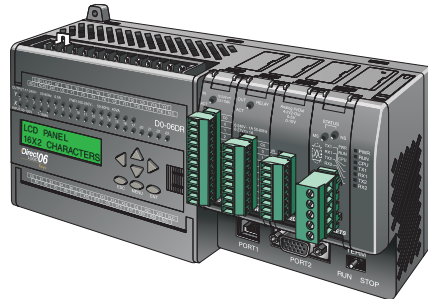

NOTE: The DL05 CPU's analog feature for this module requires **DirectSOFT32** Version 3.0c (or later) and firmware version 5.20 (or later). The DL06 requires **DirectSOFT32** version V4.0, build 16 (or later) and firmware version 2.30 (or later). See our website for more information: www.automationdirect.com.

The following tables provide the specifications for the F0-08ADH -1 Analog Input Module. Review these specifications to make sure the module meets your application requirements.

Input Specifications	
Inputs per module	8
Input Range	0-20 mA
Resolution	16-bit, 0.305 μ A/bit
Input Type	Single Ended (one common)
Maximum Continuous Overload	\pm 31mA
Input Impedance	100 ohms, 1/10W, current input
Filter Characteristics	Low pass, -3dB @ 60Hz
PLC Data Format	16-bit, Unsigned Integer, 0-FFFF (binary) or 0-65535 (BCD) [*]
Sample Duration Time	10.2 ms (time to 95% of full step change per channel)
All Channel Update Rate	81.6 ms
Open Circuit Detection Time	Zero reading within 1s
Conversion Method	Successive Approximation
Accuracy vs. Temperature	\pm 50 PPM/ $^{\circ}$ C Maximum
Maximum Inaccuracy	0.2% of range (including temperature changes)
Linearity Error (End to End)	\pm 10 count maximum; Monotonic with no missing codes
Input Stability and Repeatability	\pm 10 count maximum
Full Scale Calibration Error (incl offset)	\pm 10 count maximum
Offset Calibration Error	\pm 10 count maximum
Maximum Crosstalk at DC, 50 Hz and 60 Hz	\pm 10 count maximum
Recommended Fuse (external)	Littlefuse Series 217, 0.032 A fuse
External 24VDC Power Required	24VDC \pm 10% @ 25mA
Base Power Required (5.0 V)	25mA

^{*}Each channel requires 2 words of V-memory irrespective of the format used.

General Specifications	
Operating Temperature	0 to 55 $^{\circ}$ C (32 to 131 $^{\circ}$ F)
Storage Temperature	-20 to 70 $^{\circ}$ C (-4 to 158 $^{\circ}$ F)
Humidity	5 to 95% (non-condensing)
Environmental air	No corrosive gases permitted (EN61131-2 pollution degree 1)
Vibration	MIL STD 810C 514.2
Shock	MIL STD 810C 516.2
Field to Logic side Isolation	1800VAC applied for 1 second (100% tested)
Insulation Resistance	>10M ohms @ 500VDC
Noise Immunity	NEMA ICS3-304; Impulse 1000V @ 1ms pulse; RFI, (145MHz, 440Mhz 5W @ 15cm); Worst case error during noise disturbance is 0.5% of full scale
Agency Approvals	UL508; UL60079-15 Zone 2
Module Location	Any slot in a DL05 or DL06 System
Field Wiring	Removable Terminal Block
Weight	49g (1.7 oz.)

Connecting and Disconnecting the Field Wiring



WARNING: Before removing the analog module or the terminal block on the face of the module, disconnect power to the PLC and all field devices. Failure to disconnect power can result in damage to the PLC and/or field devices.

Wiring Guidelines

Your company may have guidelines for wiring and cable installation. If so, you should check those before you begin the installation. Here are some general things to consider:

- Use the shortest wiring route whenever possible.
- Use shielded wiring and ground the shield at the transmitter source. *Do not* ground the shield at both the module and the source.
- Do not run the signal wiring next to large motors, high current switches, or transformers. This may cause noise problems.
- Route the wiring through an approved cable housing to minimize the risk of accidental damage. Check local and national codes to choose the correct method for your application.

The F0-08ADH-1 does not supply power to field devices. You will need to power transmitters separately from the PLC.

To remove the terminal block, disconnect power to the PLC and the field devices. Pull the terminal block firmly until the connector separates from the module.

You can remove the analog module from the PLC by folding out the retaining tabs at the top and bottom of the module. As the retaining tabs pivot upward and outward, the module's connector is lifted out of the PLC socket. Once the connector is free, you can lift the module out of its slot.



NOTE: The F0-08ADH-1 analog module cannot sense the loss of analog input signals in 0-20 mA loops.

Terminal Block Specifications	
Number of Positions	13
Re-Order Number	D0-ACC-4
Pitch	0.2 inch (5.08 mm)
Wire Range	28-16 AWG Solid or Stranded Conductor; Wire strip length 5/16" (7-8 mm)
Screwdriver Size (Slotted)	0.4T x 2.5W mm (part number DN-SS1)
Screw Size	M2.5 size
Screw Torque	4.5 inch-pounds (0.52 N-m)

Wiring Diagram

Use the following diagram to connect the field wiring. If necessary, the F0-08ADH-1 terminal block can be removed to make removal of the module possible without disturbing field wiring.

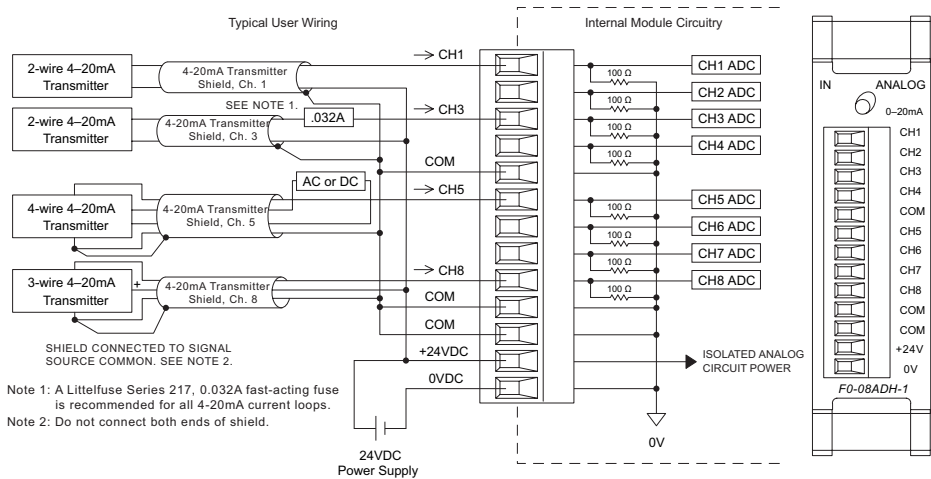

Current Loop Transmitter Impedance

Manufacturers of transmitters and transducers specify a wide variety of power sources for their products. Follow the manufacturer's recommendations.

In some cases, manufacturers specify a minimum loop or load resistance that must be used with the transmitter. The F0-08ADH-1 provides 100 ohm resistance for each channel. If your transmitter requires a load resistance below 100 ohms, you do not have to make any changes. However, if your transmitter requires a load resistance higher than 100 ohms, you need to add a resistor in series with the module.

Consider the following example for a transmitter being operated from a 30VDC supply with a recommended load resistance of 750 ohms. Since the module has a 100 ohm resistor, you need to add an additional resistor.

$$R = Tr - Mr$$

$$R = 750 - 100$$

$$R \geq 650$$

$$R = \text{Resistor to add}$$

$$Tr = \text{Transmitter requirement}$$

$$Mr = \text{Module resistance (internal 100 ohms)}$$

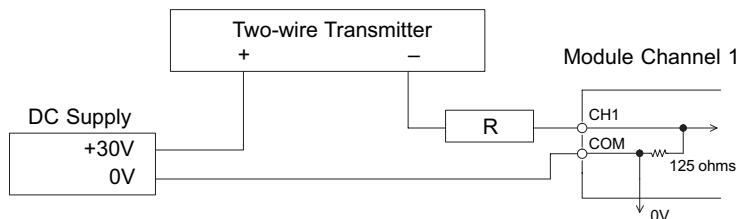

Module Operation

Channel Scanning Sequence

The DL05 and DL06 will read all eight channels of input data during each scan. Each CPU supports special V-memory locations that are used to manage the data transfer. This is discussed in more detail beginning in the section on “Special V-memory Locations”.

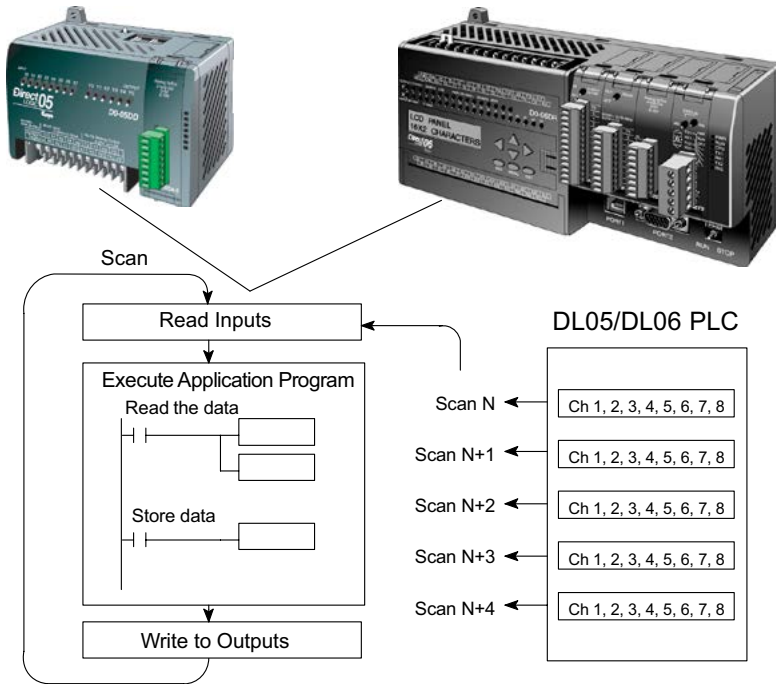

Analog Module Updates

Even though the channel updates to the CPUs are synchronous with the CPU scan, the module asynchronously monitors the analog transmitter signals and converts each signal into a 16-bit binary representation. This enables the module to continuously provide accurate measurements without slowing down the discrete control logic in the RLL program.

The module takes approximately 10.2 milliseconds to sense 95% of the change in the analog signal per channel. It takes approximately 81.6 ms to sample all channels.



NOTE: If you are comparing other manufacturers' update times (step responses) with ours, please be aware that some manufacturers refer to the time it takes to convert the analog signal to a digital value. Our analog to digital conversion takes only a few microseconds. It is the settling time of the filter that is critical in determining the full update time. Our update time specification includes the filter settling time.

Special V-memory Locations

Formatting the Analog Module Data

The DL05 and DL06 PLCs have special V-memory locations assigned to their respective option slots. These V-memory locations allow you to:

- Specify the data format (binary or BCD)
- Specify the number of channels to scan (up to 8 channels for the F0-08ADH-1)
- Specify the V-memory locations to store the input data

DL05 Data Formatting

The table below shows the special V-memory locations used by the DL05 PLC for the F0-08ADH-1.

Analog Input Module DL05 Special V-memory Locations	
Data Type and Number of Channels	V7700
Storage Pointer	V7701

Setup Data Type and Number of Active Channels

Special V-memory location 7700 is used to set the data format to either BCD or binary and to set the number of channels that will be active.

For example, assume the F0-08ADH-1 is installed in the option slot. Loading a constant of 800 into V7700 sets 8 channels active and causes the input data value to be read as a BCD number.

With the F0-08ADH-1 in the option slot, loading a constant of 8800 into V7700 sets 8 channels active, and the input data value is read as a binary number.

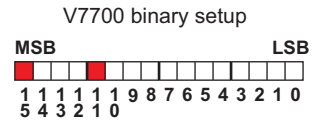
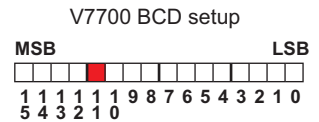

Storage Pointer Setup

V7701 is a system V-memory location used as a pointer to a user V-memory location where the analog input data is stored. The V-memory location loaded into V7701 is an octal number identifying the first user V-memory location for reading the analog input data. This V-memory location is user selectable. For example, loading O2000 causes the pointer to write Ch 1's data value to V2000 – 2001, Ch 2's data value to V2002 – 2003, Ch 3's data value to V2004 – 2005, Ch 4's data value to V2006 – 2007, Ch 5's data value to V2010 – 2011, Ch 6's data value to V2012 – 2013, Ch 7's data value to V2014 – 2015, and Ch 8's data value to V2016 – 2017.

You will find an example program that loads appropriate values to V7700 and V7701 on page 4-9.

DL06 Data Formatting

Special V-memory locations are assigned to the four option slots of the DL06 PLC. The table below shows these V-memory locations which can be used to setup the F0-08ADH-1.

Analog Input Module DL06 Special V-memory Locations				
Slot No.	1	2	3	4
Data Type and Number of Channels	V700	V710	V720	V730
Storage Pointer	V701	V711	V721	V731

Setup Data Type and Number of Active Channels

V-memory locations 700, 710, 720, and 730 are used to set the data format to either BCD or binary and to set the number of channels that will be active.

For example, assume the F0-08ADH-1 is installed in slot 1. Loading a constant of 800 into V700 sets 8 channels active and causes the input data value to be read as a BCD number.

With the F0-08ADH-1 in slot 1, loading a constant of 8800 into V700 sets 8 channels active, and the input data value is read as a binary number.

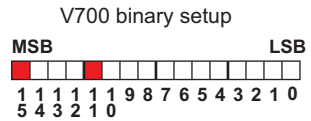
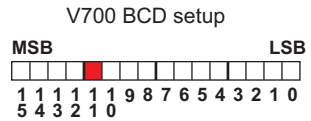

Storage Pointer Setup

V-memory locations 701, 711, 721 and 731 are special locations used as storage pointers. A V-memory address is loaded into this location as an octal number identifying the first user V-memory location for the analog input data. This V-memory location is user selectable. For example, loading O2000 causes the pointer to write Ch 1's data value to V2000 – 2001, Ch 2's data value to V2002 – 2003, Ch 3's data value to V2004 – 2005, Ch 4's data value to V2006 – 2007, Ch 5's data value to V2010 – 2011, Ch 6's data value to V2012 – 2013, Ch 7's data value to V2014 – 2015, and Ch 8's data value to V2016 – 2017.

You will find an example program that loads appropriate values to V700 and V701 beginning on page 4-10.

Using the Pointer in Your Control Program

DL05 Pointer Method Using Conventional Ladder Logic



NOTE: The proper use of the DL05 pointer requires that the V-memory address be written to the special memory location on the first scan only. Use the SPO bit as a permissive contact when using the code shown below.

The example program below shows how to setup the special V-memory locations. This rung can be placed anywhere in the ladder program or in the initial stage if you are using stage programming instructions.

This is all that is required to read the analog input data into V-memory locations. Once the data is in V-memory you can perform math on the data, compare the data against preset values, and so forth. V2000 is used in the example but you can use any user V-memory location.

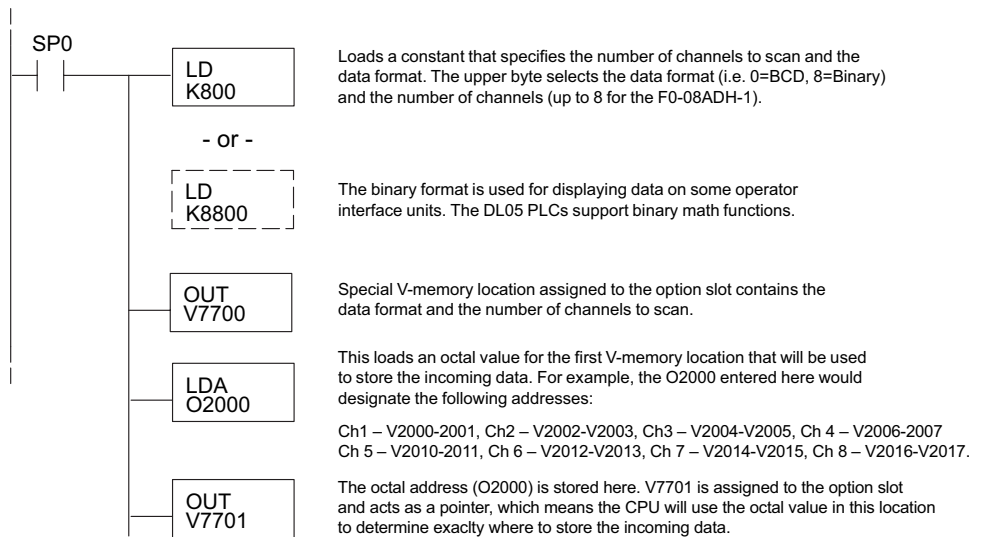

DL05 Pointer Method Using the IBox Instruction Available in DirectSOFT5

The following logic accomplishes the same thing as the previous ladder example, but it uses the IBox instruction ANLGIN.

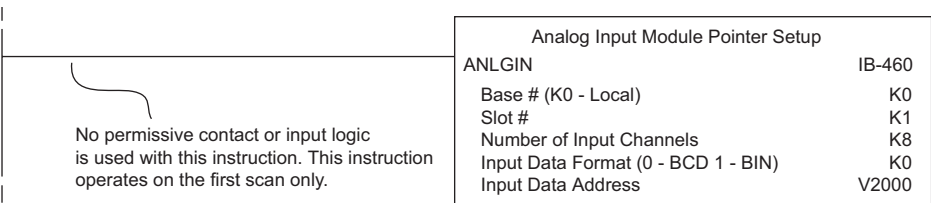

DL06 Pointer Method Using Conventional Ladder Logic



NOTE: The proper use of the DL06 pointer requires that the V-memory address be written to the special memory location on the first scan only. Use the SPO bit as a permissive contact when using the code shown below.

Use the special V-memory table below as a guide to setup the storage pointer in the following example for the DL06. Slot 1 is the left most option slot.

Analog Input Module DL06 Special V-memory Locations				
	1	2	3	4
No. of Channels	V700	V710	V720	V730
Input Pointer	V701	V711	V721	V731

The F0-08ADH-1 can be installed in any available DL06 option slot. The ladder diagram below shows how to set up these locations with the module installed in slot 1 of the DL06. Use the above table to determine the pointer values if locating the module in any of the other slot locations. Place this rung anywhere in the ladder program or in the initial stage if you are using stage programming instructions.

This logic is all that is required to read the analog input data into V-memory locations. Once the data is in V-memory you can perform mathematical calculations with the data, compare the data against preset values, and so forth. In the example, V2000 is used, but you can use any user V-memory location.

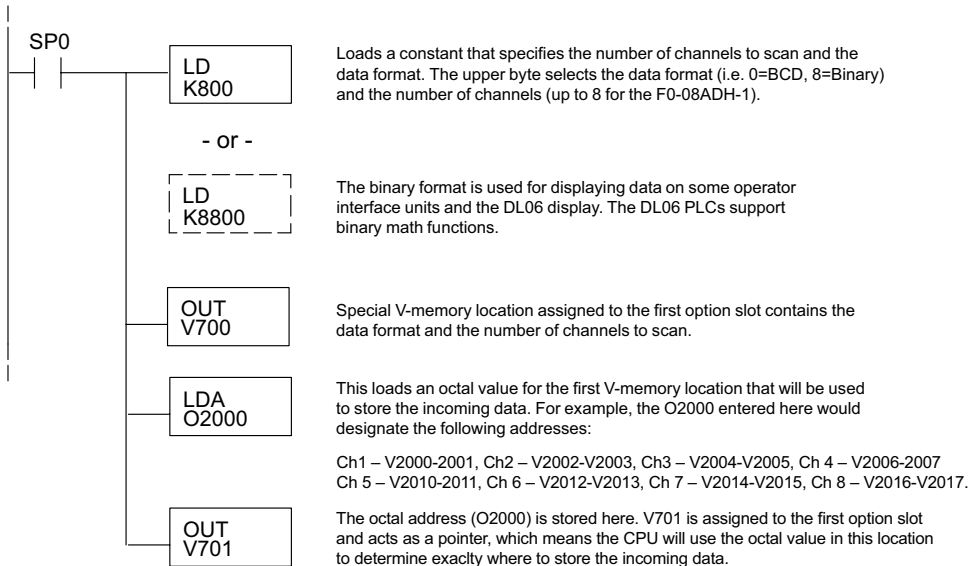

DL06 Pointer Method Using the IBox Instruction Available in DirectSOFT6

The following logic accomplishes the same thing as the previous ladder example, but it uses the IBox instruction ANLGIN.

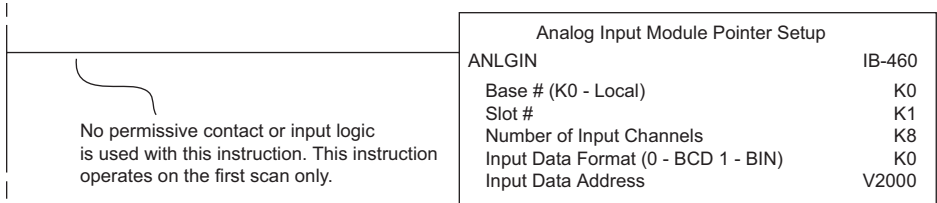

Conversions

Scaling the Input Data

Many applications call for measurements in engineering units, which can be more meaningful than raw data. Convert to engineering units using the formula shown to the right.

You may have to make adjustments to the formula depending on the scale you choose for the engineering units.

For example, if you wanted to measure pressure (PSI) from 0.0 to 99.9 then you would have to multiply the analog value by 10 in order to imply a decimal place when you view the value with the programming software or a handheld programmer. Notice how the calculations differ when you use the multiplier.

Analog Value of 32375, slightly less than half scale, should yield 49.4 PSI.

$$\text{Units} = A \frac{H-L}{65535} + L$$

H = High limit of the engineering unit range
 L = Low limit of the engineering unit range
 A = Analog value (0 – 65535)

Example without multiplier	Example with multiplier
Units = A $\frac{H-L}{65535} + L$	Units = 10 x A $\frac{H-L}{65535} + L$
Units = 32375 $\frac{100-0}{65535} + 0$	Units = 323750 $\frac{100-0}{65535} + 0$
Units = 49	Units = 494

The Conversion Program in Standard Ladder Logic

The following example shows how you would write the program to perform the engineering unit conversion. This example assumes you have BCD data loaded into the appropriate V-memory locations using instructions that apply for the model of CPU you are using.

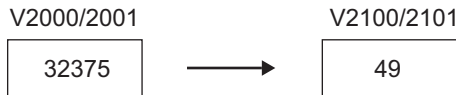
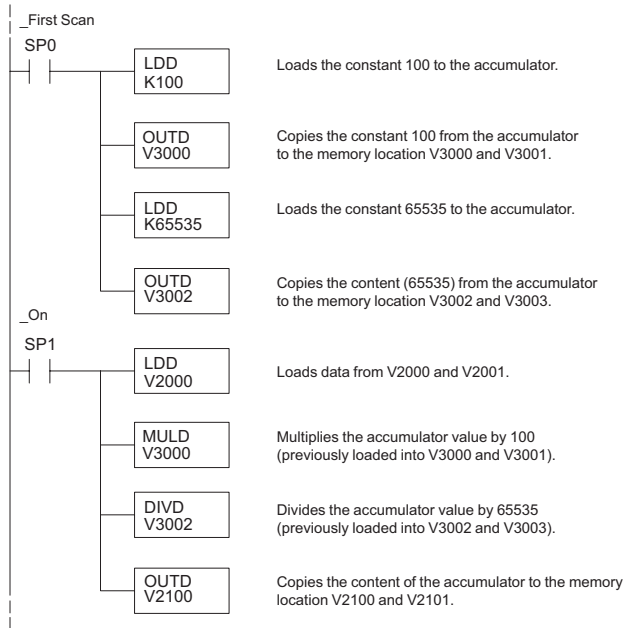

Analog and Digital Value Conversions

Sometimes it is useful to convert between the signal levels and the digital values. This is especially helpful during machine start-up or troubleshooting. The following table provides formulas to make this conversion easier.

Range	If you know the digital value	If you know the analog signal level
0 to 20mA	$A = \frac{20}{65535} \cdot D$	$D = \frac{65535}{20} \cdot A$

For example, if you have measured the signal as 10mA, you can use the formula to determine the digital value that should be stored in the V-memory location that contains the data.

$$D = \frac{65535}{20} \cdot A$$

$$D = \frac{65535}{20} \cdot 10\text{mA}$$

$$D = 32767$$

Module Resolution

Analog Data Bits

Two 16-bit words are reserved for the analog data whether you are using BCD or binary data formatting. The 16 bits in the low word represent the analog data in binary format.

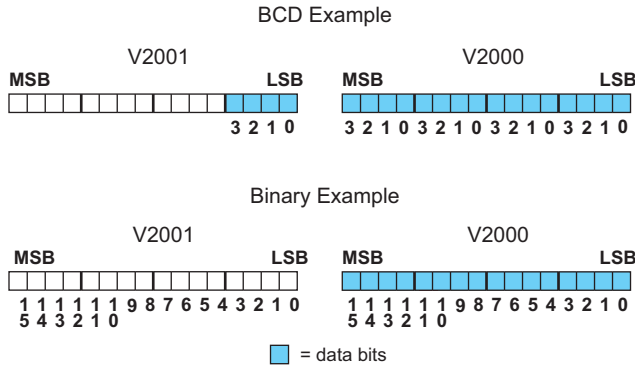

Resolution Details

Since the module has 16-bit resolution, the analog signal is converted into 65,536 counts ranging from 0 - 65,535 (2^{16}). A 0mA signal would be 0 and a 20mA signal would be 65535. This is equivalent to a binary value of 0000 0000 0000 0000 to 1111 1111 1111 1111, or 000 to FFFF hexadecimal.

Each count can also be expressed in terms of the signal level by using the following equation:

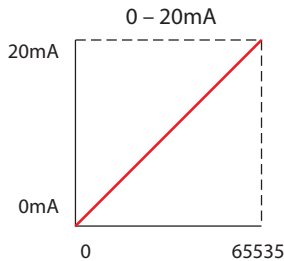

$$\text{Resolution} = \frac{H - L}{65535}$$

H = high limit of the signal range

L = low limit of the signal range

The following table shows the smallest detectable signal change that will result in one LSB change in the data value for each increment of the signal change.

mA Range	Signal Span (H - L)	Divide By	Smallest Detectable Change
0 to 20mA	20mA	65535	0.3052µA

Analog Input Ladder Logic Filter

PID Loops / Filtering

Please refer to the “PID Loop Operation” chapter in the DL06 or DL05 User Manual for information on the built-in PV filter (DL05/06) and the ladder logic filter (DL06 only) shown below. A filter must be used to smooth the analog input value when auto tuning PID loops to prevent giving a false indication of loop characteristics.

Smoothing the Input Signal (DL06 only)

The filter logic can also be used in the same way to smooth the analog input signal to help stabilize PID loop operation or to stabilize the analog input signal value for use with an operator interface display, etc.



WARNING: The built-in and logic filters are not intended to smooth or filter noise generated by improper field device wiring or grounding. Small amounts of electrical noise can cause the input signal to bounce considerably. Proper field device wiring and grounding must be done before attempting to use the filters to smooth the analog input signal.

Binary Data Format Filter Using Ladder Logic

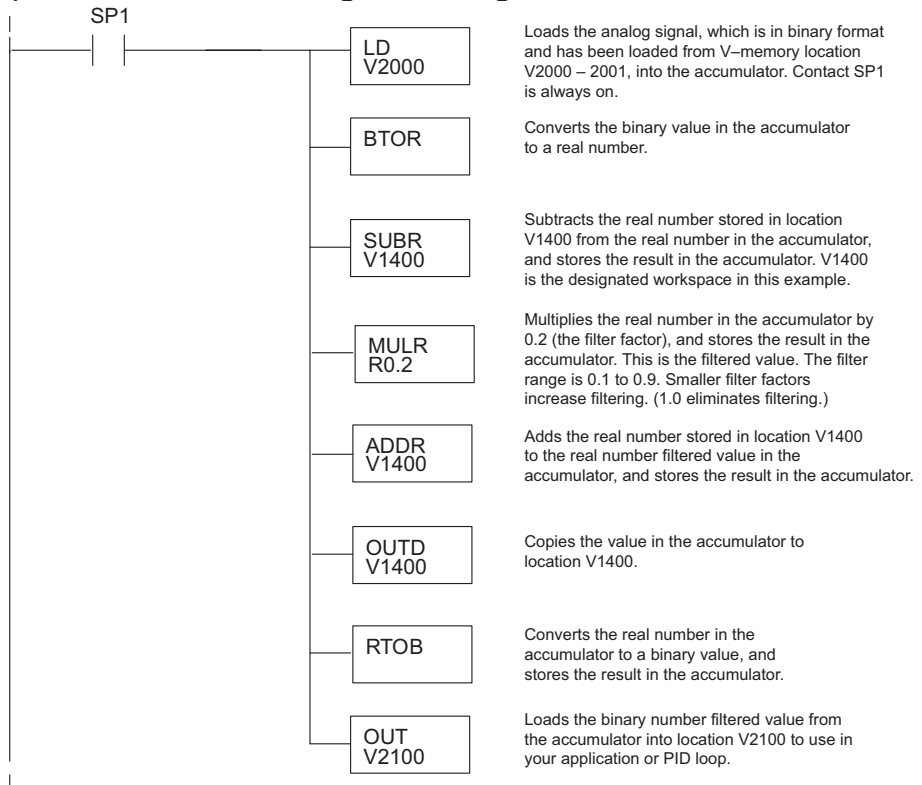



NOTE: Be careful not to do a multiple number conversion on a value. For example, if you are using the pointer method in BCD format to get the analog value, it must be converted to binary (BIN) as shown below. If you are using the pointer method in Binary format, the conversion to binary (BIN) instruction is not needed.

BCD Data Format Filter Using Ladder Logic

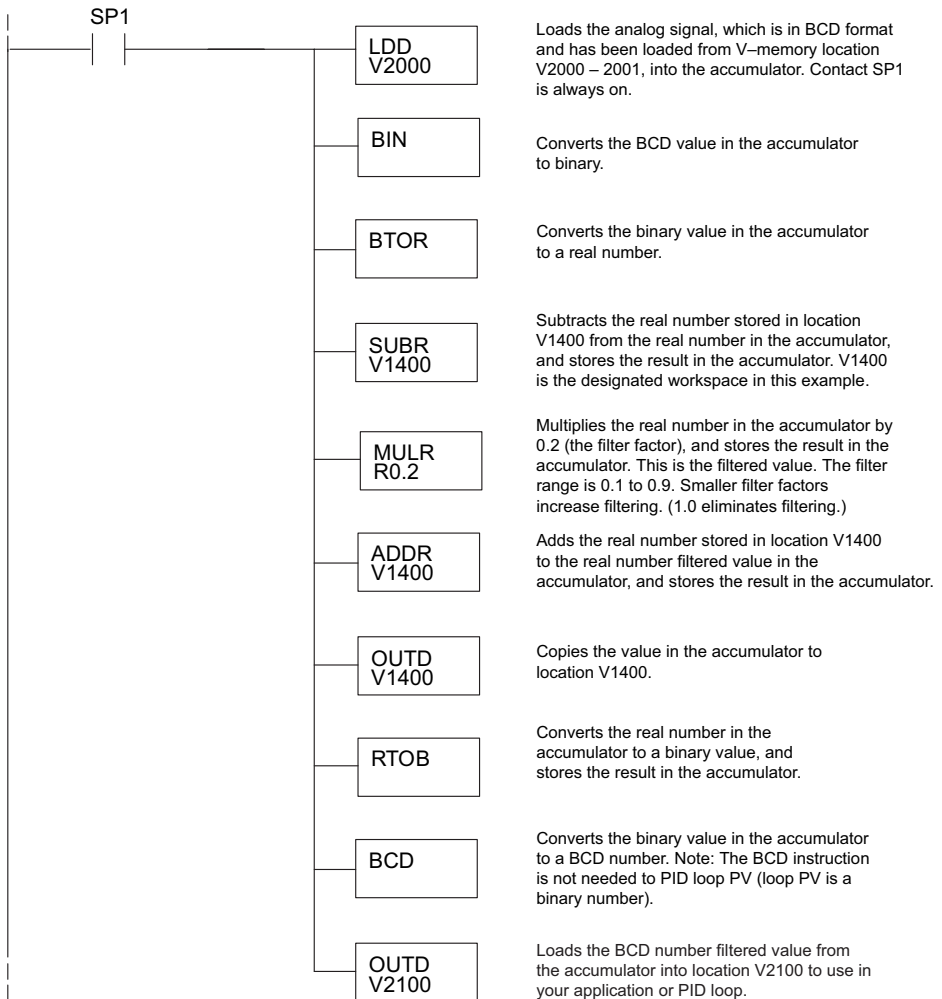

Example Code to Scale a 4–20 mA Signal to 0–1000 BCD

(For applications where the field transmitter sends a 4–20 mA signal to the analog input card.)

This example will scale the first input, a double word BCD value located at V2000 and V2001, as a 4–20 mA input signal from 0–1000. Because the input card ranges from 0–20 mA instead of 4–20 mA, an offset value must be used to deal with the 0–4 mA values. Any value below a 4mA (13107) value is forced to a 4mA (13107) value.

Load V2020 with the maximum engineering value (1000 in this example). Load V2022 with the maximum 16-bit value after the 4mA value (13107) is subtracted.

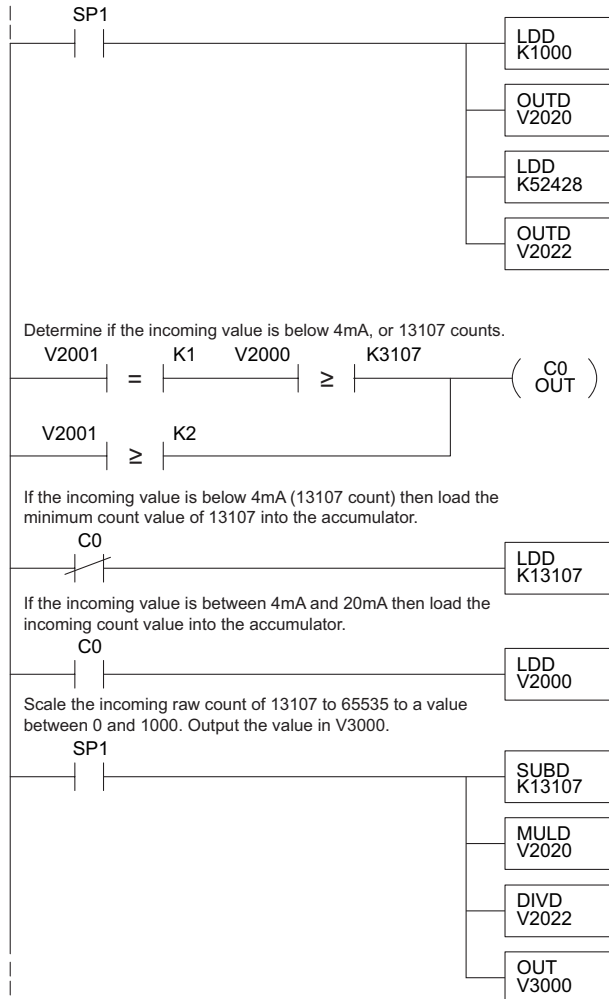

Example Code to Scale a 4–20 mA Signal to 0–1000 Binary

(For applications where the field transmitter sends a 4–20 mA signal to the analog input card.)

This example will scale the first input, a binary/decimal value located at V2000 (the CPU reserves two words for each channel so V2000 and V2001 are reserved), as a 4–20 mA input signal from 0–1000. Because the input card ranges from 0–20 mA instead of 4–20 mA, an offset value must be used to deal with the 0–4 mA values. Any value below a 4mA (13107 or 3333h) value is forced to a 4mA (13107 or 3333h) value.

Load V2020 with the maximum engineering value (1000 or 3E8h in this example). Load V2022 with the maximum 16-bit value after the 4mA value (13107 or 3333h) is subtracted.

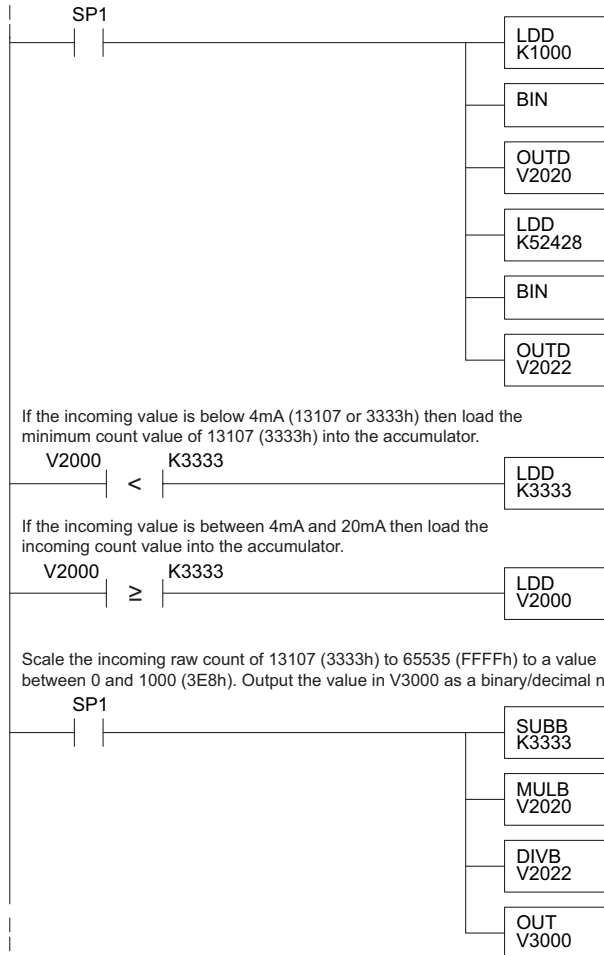

F0-04AD-2, 4-CHANNEL ANALOG VOLTAGE INPUT



In This Chapter...

Module Specifications	5-2
Setting the Module Jumpers	5-4
Connecting and Disconnecting the Field Wiring	5-5
Wiring Diagram	5-5
Module Operation	5-6
Special V-memory Locations	5-7
Using the Pointer in Your Control Program	5-9
Scale Conversions	5-11
Module Resolution.....	5-14
Analog Input Ladder Logic Filter	5-15

Module Specifications

The F0-04AD-2 Analog input module offers the following features:

- The DL05 and DL06 will read all four channels in one scan.
- The removable terminal block makes it possible to remove the module without disconnecting the field wiring.
- Analog inputs can be used as process variables for the four (4) PID loops in the DL05 CPU and the eight (8) PID loops in the DL06 CPUs.
- On-board active analog filtering and RISC-like microcontroller provide digital signal processing to maintain precise analog measurements in noisy environments.



NOTE: The DL05 CPU's analog feature for this module requires **DirectSOFT32 Version 3.0c (or later)** and firmware version 2.10 (or later). The DL06 requires **DirectSOFT32 version V4.0, build 16 (or later)** and firmware version 1.00 (or later). See our website for more information: www.automationdirect.com.

The following tables provide the specifications for the F0-04AD-2 Analog Input Module. Review these specifications to make sure the module meets your application requirements.

Input Specifications	
Number of Channels	4, single ended (one common)
Input Range	0 to 5VDC or 0 to 10VDC (jumper selectable)
Resolution	12 bit (1 in 4096)
Step Response	10.0 ms to 95% of full step change
Crosstalk	-80dB, 1/2 count maximum*
Active Low-pass Filtering	-3dB at 300Hz (-12dB per octave)
Input Impedance	Greater than 20k Ω
Absolute Maximum Ratings	$\pm 15V$
Linearity Error (End to End)	± 2 counts maximum*
Input Stability	± 1 count *
Gain Error	± 6 counts maximum *
Offset Error	± 2 counts maximum*
Maximum Inaccuracy	$\pm 0.3\%$ @ 25°C (77°F) $\pm 0.6\%$ 0 to 60°C (32 to 140°F)
Accuracy vs. Temperature	± 100 ppm /°C typical
* One count in the specification tables is equal to one least significant bit of the analog data value (1 in 4096).	

General Specifications	
PLC Update Rate	4 input channels per scan
16-bit Data Word	12 binary data bits
Operating Temperature	0 to 60° C (32 to 140° F)
Storage Temperature	-20 to 70° C (-4 to 158° F)
Relative Humidity	5 to 95% (non-condensing)
Environmental Air	No corrosive gases permitted
Vibration	MIL STD 810C 514.2
Shock	MIL STD 810C 516.2
Noise Immunity	NEMA ICS3-304
Power Budget Requirement	75mA @ 5 VDC (supplied by base)
Connector	Phoenix Mecano, Inc. Part No. AK1550/8-3.5 - green
Connector Wire Size	28-16 AWG
Connector Screw Torque	0.4 N·m
Connector Screwdriver Size	DN-SS1 (recommended)

Setting the Module Jumpers

The position of the J2 jumpers determines the input signal levels. You can choose between 0–5 VDC or 0–10 VDC. The module ships with the jumpers installed connecting the pins. In this position, the input signal level is 0–5 VDC. To select 0–10 VDC signals, use the jumper selection chart located on the module. One or more channels can be selected for 0–10 VDC input signal level by removing the jumper from the connecting pin of the appropriate channel. This allows you to have some channels selected for 0–5 VDC signals and other channels selected for 0–10 VDC signals.

J2 jumpers shown below are configured as CH1 and CH4 set for 0–10V, and CH2 and CH3 set for 0–5V.

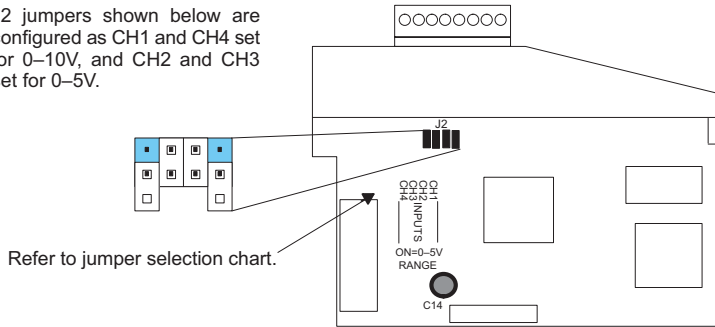

WARNING: Before removing the analog module or the terminal block on the face of the module, disconnect power to the PLC and all field devices. Failure to disconnect power can result in damage to the PLC and/or field devices.

Connecting and Disconnecting the Field Wiring

Wiring Guidelines

Your company may have guidelines for wiring and cable installation. If so, you should check those before you begin the installation. Here are some general things to consider:

- Use the shortest wiring route whenever possible.
- Use shielded wiring and ground the shield at the transmitter source. *Do not* ground the shield at both the module and the source.
- Do not run the signal wiring next to large motors, high current switches, or transformers. This may cause noise problems.
- Route the wiring through an approved cable housing to minimize the risk of accidental damage. Check local and national codes to choose the correct method for your application.

A separate transmitter power supply may be required, depending on the type of transmitter being used.

This module has a removable connector to make wiring and module removal easier. To remove the terminal block, disconnect power to the PLC and the field devices. Pull the terminal block firmly until the connector separates from the module.

The analog module can be removed from the PLC by folding out the retaining tabs at the top and bottom of the module. As the retaining tabs pivot upward and outward, the module's connector is lifted out of the PLC socket. Once the connector is free, you can lift the module out of its slot.

Wiring Diagram

Use the following diagram to connect the field wiring. If necessary, the terminal block can be removed to make removal of the module possible without disturbing field wiring.

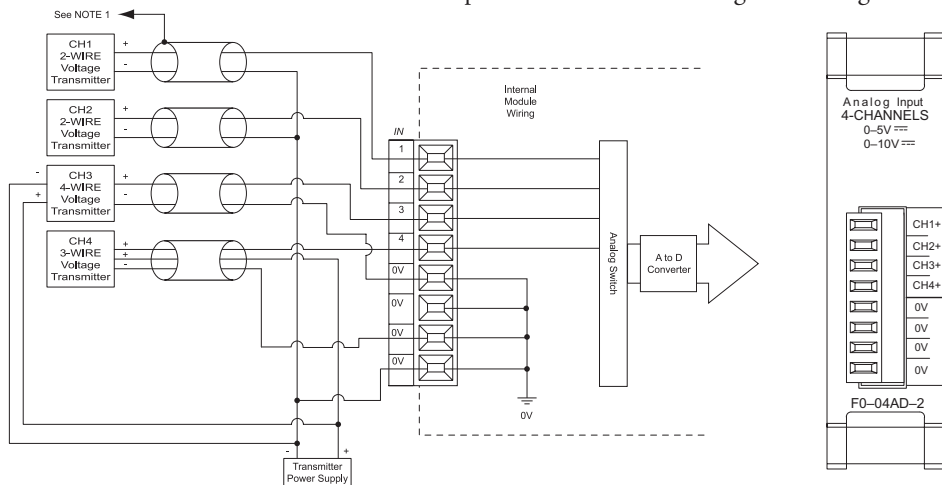

NOTE 1: Ground shields at the signal source.

NOTE 2: Connect all external power supply commons.

NOTE 3: To ensure that readings on unused channels are zero, install a jumper between the CHx and COM terminals on all unused channels.

Module Operation

Input Channel Update Sequence

The DL05 and DL06 read four channels of input data during each scan. The CPU supports special V-memory locations that are used to manage the data transfer. This is discussed in more detail on the next page, “Special V-memory Locations”.

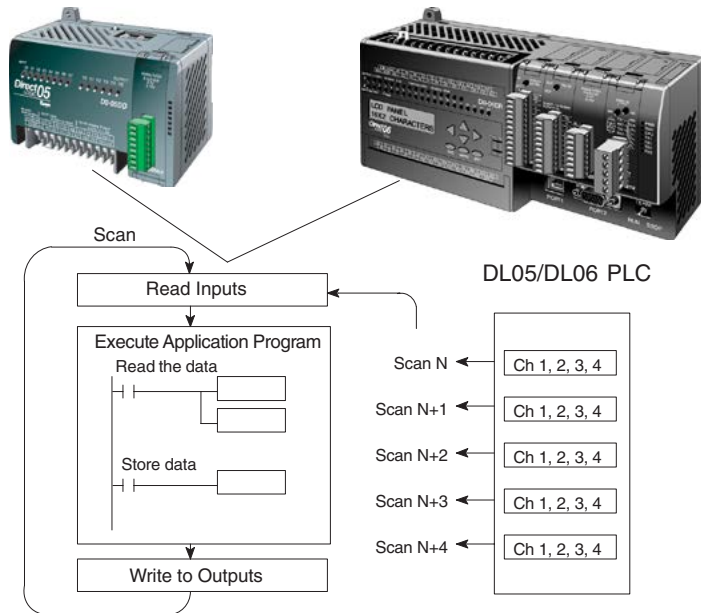

Analog Module Updates

Even though the channel updates to the CPU are synchronous with the CPU scan, the module asynchronously monitors the analog transmitter signals and converts each signal into a 12-bit binary representation. This enables the module to continuously provide accurate measurements without slowing down the discrete control logic in the RLL program.

The module takes approximately 10 milliseconds to sense 95% of the change in the analog signal. For the vast majority of applications, the process changes are much slower than these updates.



NOTE: If you are comparing other manufacturers' update times (step responses) with ours, please be aware that some manufacturers refer to the time it takes to convert the analog signal to a digital value. Our analog to digital conversion takes only a few microseconds. It is the settling time of the filter that is critical in determining the full update time. Our update time specification includes the filter settling time.

Special V-memory Locations

Formatting the Module Data

The DL05 and DL06 PLCs have special V-memory locations assigned to their respective option slots. These V-memory locations allow you to:

- Specify the data format (binary or BCD)
- Specify the number of channels to scan (4 channels for the F0-04AD-2)
- Specify the V-memory locations to store the input data

DL05 Data Formatting

The table below shows the special V-memory locations which are used by the DL05 PLC for the F0-04AD-2.

Analog Input Module DL05 Special V-memory Locations	
Data Type and Number of I/O Channels	V7700
Input Storage Pointer	V7701

Structure of V7700

Special V-memory location 7700 identifies that a F0-04AD-2 module is installed in the DL05 option slot and the data type to be either binary or BCD.

Loading a constant of 400 into V7700 identifies a 4 channel analog input module is installed in the DL05 option slot, and reads the input data values as BCD numbers.

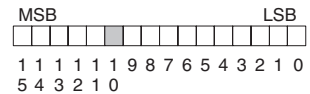

Loading a constant of 8400 into V7700 identifies a 4 channel analog input module is installed in the DL05 option slot, and reads the input data values as binary numbers.

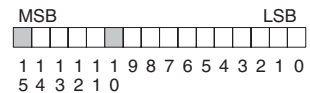

Structure of V7701

V7701 is a system V-memory location used as a pointer to a user V-memory location where the analog input data is stored. The V-memory location loaded into V7701 is an octal number identifying the first user V-memory location for reading the analog input data. This V-memory location is user selectable. For example, loading O2000 causes the pointer to write Ch 1's data value to V2000, Ch 2's data value to V2001, Ch 3's data value to V2002, and Ch 4's data value to V2003.

You will find an example program that loads appropriate values to V7700 and V7701 on page 5-9.

DL06 Data Formatting

Special V-memory locations are assigned to the four option module slots of the DL06 PLC. The table below shows these V-memory locations which can be used for the F0-04AD-2.

Analog Input Module DL06 Special V-memory Locations				
Slot No.	1	2	3	4
Number of Channels	V700	V710	V720	V730
Input Pointer	V701	V711	V721	V731

Setup Data Type and Number of Channels

V-memory locations 700, 710, 720 and 730 are used to set the data format to be read in either binary or BCD, and to set the number of channels that will be active.

For example, the F0-04AD-2 is installed in slot 1. Loading a constant of 400 into V700 sets 4 channels active, and the input data value is read as a BCD number.

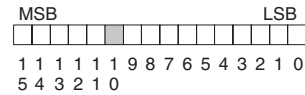

With the F0-04AD-2 in slot 1, loading a constant of 8400 into V700 sets 4 channels active, and the input data value is read as a binary number.

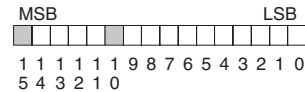

Storage Pointer Setup

V-memory locations 701, 711, 721 and 731 are special locations used as storage pointers for the analog input data. With the analog module installed in slot 4, the V-memory location loaded in V731, for instance, is an octal number identifying the first user V-memory location to read the analog input data. This V-memory location is user selectable. For example, loading O2000 using the LDA instruction causes the pointer to write Ch 1's data value to V2000, Ch 2's data value to V2001, CH 3's data value to V2002 and Ch 4's data value to V2003.

You will find an example program that loads appropriate values to V700 and V701 on page 5-10.

Using the Pointer in Your Control Program

DL05 Pointer Method

The DL05 CPU examines the pointer values (the memory locations identified in V7700 and V7701) on the first scan only.

The example program below shows how to setup these locations. This rung can be placed anywhere in the ladder program or in the initial stage if you are using stage programming instructions.

This is all that is required to read the analog input data into V-memory locations. Once the data is in V-memory you can perform math on the data, compare the data against preset values, and so forth. V2000 is used in the example but you can use any user V-memory location.

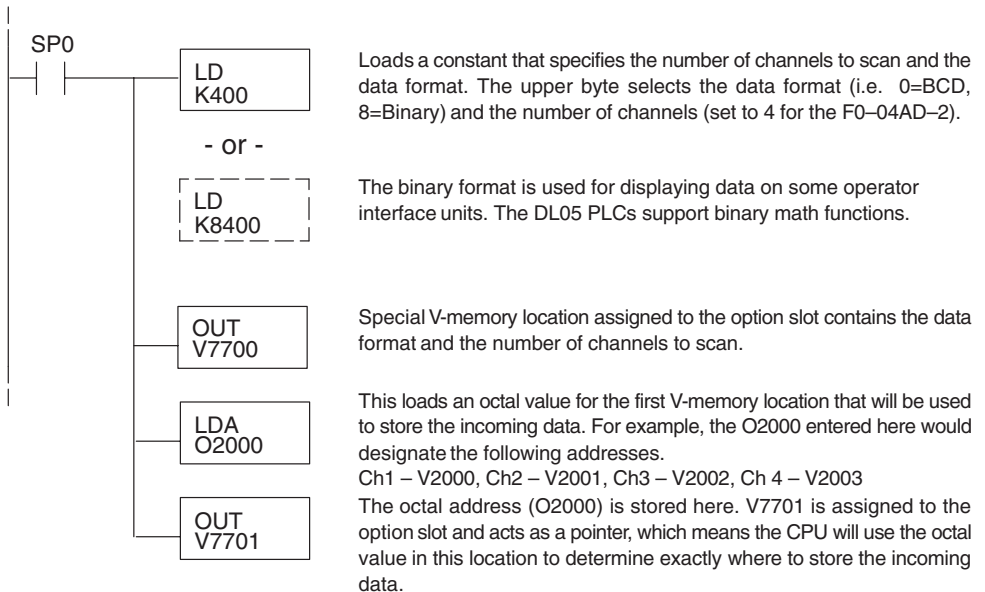

DL06 Pointer Method

Use the special V-memory table below as a guide to setup the pointer values in the following example for the DL06. Slot 1 is the left most option slot. The CPU will examine the pointer values at these locations only after a mode transition, first scan only.

Analog Input Module DL06 Special V-memory Locations				
Slot No.	1	2	3	4
Number of Channels	V700	V710	V720	V730
Input Pointer	V701	V711	V721	V731

The F0-04AD-2 can be installed in any available DL06 option slot. Using the example program from the previous page, but changing the V-memory addresses, the ladder diagram below shows how to setup these locations with the module installed in slot 1 of the DL06. Use the above table to determine the pointer values if locating the module in any of the other slot locations. Place this rung anywhere in the ladder program or in the initial stage if you are using stage programming instructions.

Like the DL05 example, this logic is all that is required to read the analog input data into V-memory locations. Once the data is in V-memory you can perform mathematical calculations with the data, compare the data against preset values, and so forth. V2000 is used in the example but you can use any user V-memory location.

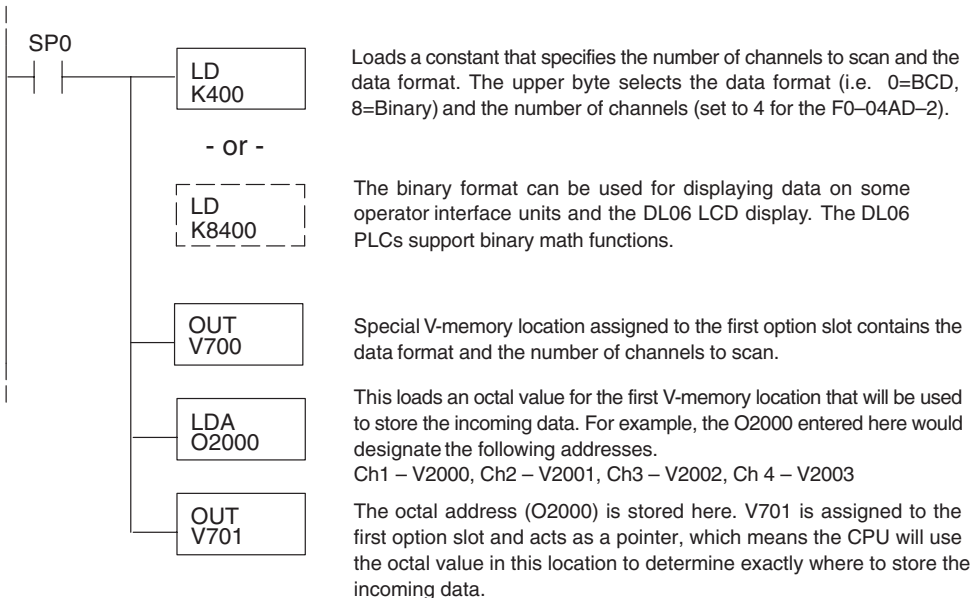

Scale Conversions

Scaling the Input Data

Many applications call for measurements in engineering units, which can be more meaningful than raw data. Convert to engineering units using the formula shown to the right.

You may have to make adjustments to the formula depending on the scale you choose for the engineering units.

$$\text{Units} = A \frac{H-L}{4095} + L$$

H = High limit of the engineering unit range

L = Low limit of the engineering unit range

A = Analog value (0 – 4095)

For example, if you wanted to measure pressure (PSI) from 0.0 to 100.0 then you would have to multiply the analog value by 10 in order to imply a decimal place when you view the value with the programming software or a handheld programmer. Notice how the calculations differ when you use the multiplier.

Analog Value of 2024, slightly less than half scale, should yield 49.4 PSI

Example without multiplier

$$\text{Units} = A \frac{H-L}{4095} + L$$

$$\text{Units} = 2024 \frac{100-0}{4095} + 0$$

$$\text{Units} = 49$$

Example with multiplier

$$\text{Units} = 10 A \frac{H-L}{4095} + L$$

$$\text{Units} = 20240 \frac{100-0}{4095} + 0$$

$$\text{Units} = 494$$

The Conversion Program

The following example shows how you would write the program to perform the engineering unit conversion from input data formats 0–4095. This example assumes the raw input data read at V2000 is in BCD format.

Note: this example uses SP1, which is always on. You could also use an X, C, etc., permissive contact.

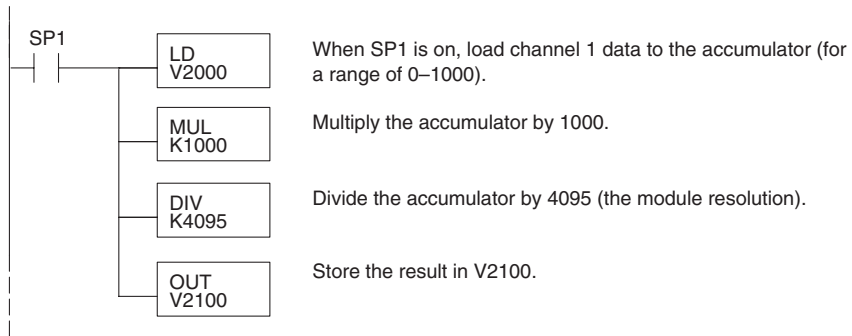

Analog and Digital Value Conversions

Sometimes it is useful to convert between the signal levels and the digital values. This is especially helpful during machine startup or troubleshooting. The following table provides formulas to make this conversion easier.

Range	If you know the digital value	If you know the analog signal level
0 to 5V	$A = \frac{5D}{4095}$	$D = \frac{4095}{5} (A)$
0 to 10V	$A = \frac{10D}{4095}$	$D = \frac{4095}{10} (A)$

For example, if you are using the 0–10 V range and you need a 6V signal level, use this formula to determine the digital value (D) that will be stored in the V-memory location that contains the data.

$$D = \frac{4095}{10} (A)$$

$$D = \frac{4095}{10} (6V)$$

$$D = (409.5) (6)$$

$$D = 2457$$

Module Resolution

Analog Data Bits

The first twelve bits represent the analog data in binary format.

Bit	Value	Bit	Value
0	1	6	64
1	2	7	128
2	4	8	256
3	8	9	512
4	16	10	1024
5	32	11	2048

MSB												LSB											
[] [] [] [] [] [] [] [] [] [] [] []												[] [] [] [] [] [] [] [] [] [] [] []											
												1 1 9 8 7 6 5 4 3 2 1 0											
												1 0											

[] = data bits

Resolution Details

Since the module has 12-bit resolution, the analog voltage signal is converted into 4096 counts ranging from 0–4095 (2^{12}). For example, with a 0 to 10V range, a 0V signal would be a count value of 0, and a 10V signal would produce a count value of 4095. This is equivalent to a binary value of 0000 0000 0000 to 1111 1111 1111, or 000 to FFF hexadecimal.

Each count can also be expressed in terms of the signal level by using the following equation:

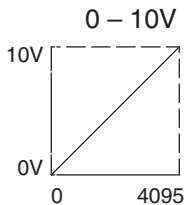

$$\text{Resolution} = \frac{H - L}{4095}$$

H = high limit of the signal range

L = low limit of the signal range

The following table shows the smallest detectable signal change that will result in one LSB change in the data value for each increment of the signal change.

Voltage Range	Signal Span (H - L)	Divide By	Smallest Detectable Change
0 to 5V	5 volts	4095	1.22 mV
0 to 10V	10 volts	4095	2.44 mV

Analog Input Ladder Logic Filter

PID Loops / Filtering:

Please refer to the “PID Loop Operation” chapter in the DL06 or DL05 User Manual for information on the built-in PV filter (DL05/06) and the ladder logic filter (DL06 only) shown below. A filter must be used to smooth the analog input value when auto tuning PID loops to prevent giving a false indication of loop characteristics.

Smoothing the Input Signal (DL06 only):

The filter logic can also be used in the same way to smooth the analog input signal to help stabilize PID loop operation or to stabilize the analog input signal value for use with an operator interface display, etc.



WARNING: The built-in and logic filters are not intended to smooth or filter noise generated by improper field device wiring or grounding. Small amounts of electrical noise can cause the input signal to bounce considerably. Proper field device wiring and grounding must be done before attempting to use the filters to smooth the analog input signal.

Using Binary Data Format

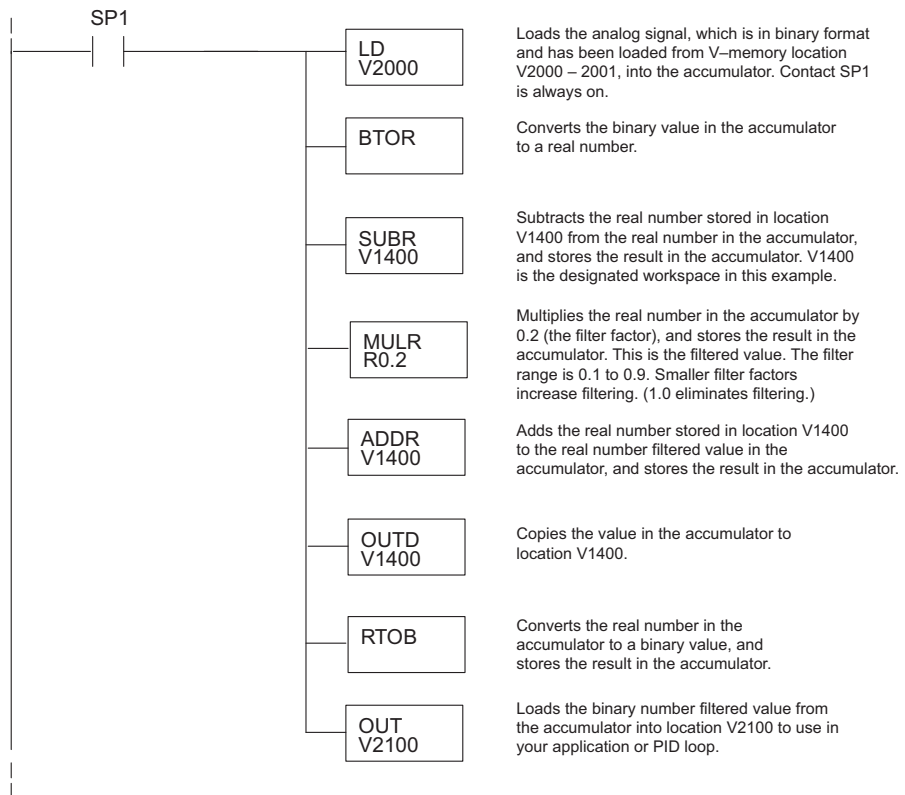



NOTE: Be careful not to do a multiple number conversion on a value. For example, if you are using the pointer method in BCD format to get the analog value, it must be converted to binary (BIN) as shown below. If you are using the pointer method in Binary format, the conversion to binary (BIN) instruction is not needed.

Using BCD Data Format

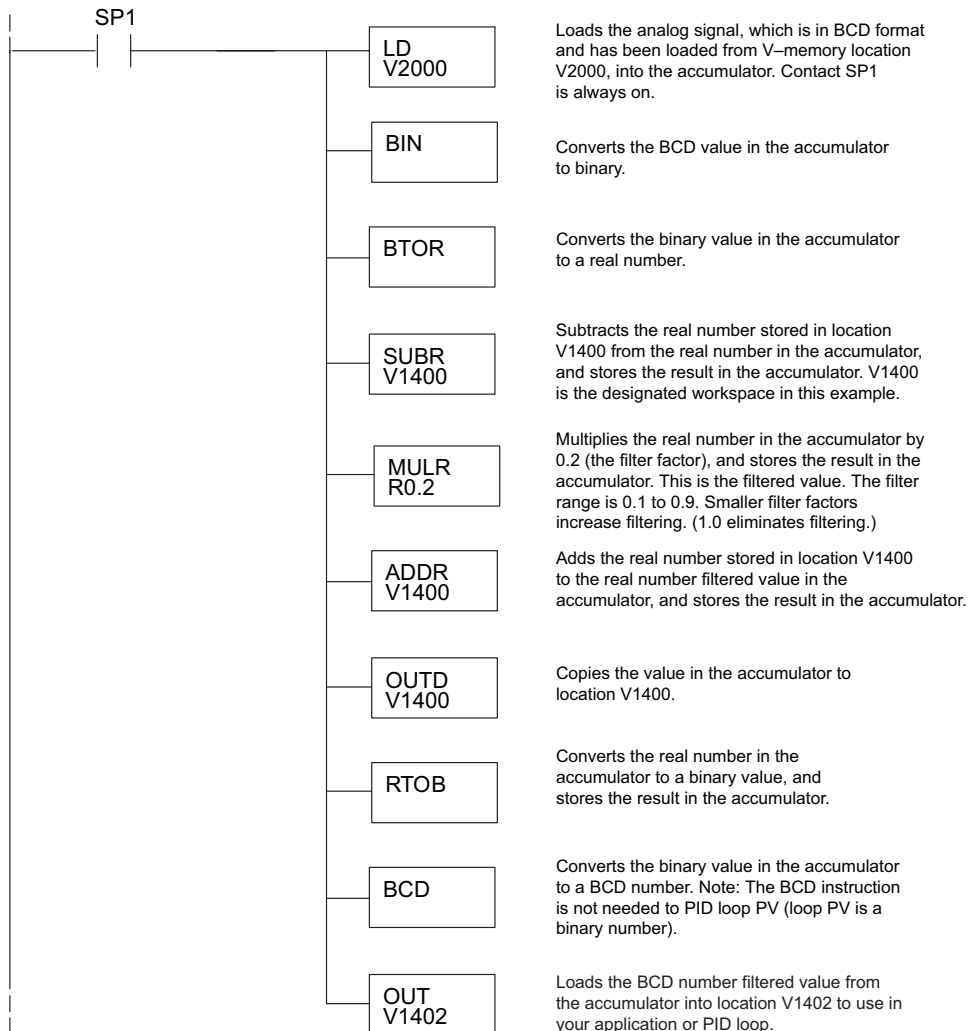

F0-08ADH-2, 8-CHANNEL ANALOG VOLTAGE INPUT



In This Chapter...

Module Specifications	6-2
Setting the Module Jumpers	6-4
Connecting and Disconnecting the Field Wiring	6-5
Wiring Diagram	6-6
Module Operation	6-7
Special V-memory Locations	6-8
Using the Pointer in Your Control Program	6-10
Scale Conversions	6-12
Module Resolution.....	6-15
Analog Input Ladder Logic Filter	6-16

Module Specifications

The F0-08ADH-2 Analog Input module offers the following features:

- The DL05 and DL06 will read all eight channels in one scan.
- The removable terminal block simplifies module replacement.
- Analog inputs can be used as process variables for the four (4) PID loc in the DL05 and the eight (8) PID loops in the DL06 CPUs.
- On-board active analog filtering and RISC-like microcontroller provide digital signal processing to maintain precise analog measurements in noisy environments.

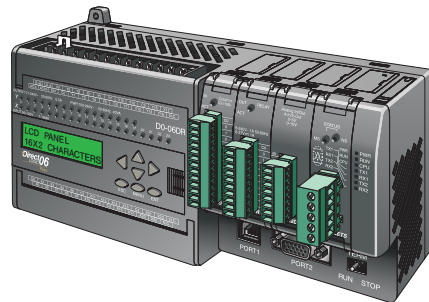

NOTE: The DL05 CPU's analog feature for this module requires **DirectSOFT32** Version 3.0c (or later) and firmware version 5.20 (or later). The DL06 requires **DirectSOFT32** version V4.0, build 16 (or later) and firmware version 2.30 (or later). See our website for more information: www.automationdirect.com.

The following tables provide the specifications for the F0-08ADH-2 Analog Input Module. Review these specifications to make sure the module meets your application requirements.

Input Specifications	
Inputs per module	8
Input Range	0–5 VDC or 0–10 VDC (Jumper selectable)
Resolution	16-bit, 76 μ V /bit or 152 μ V /bit
Input Type	Single Ended (one common)
Maximum Continuous Overload	\pm 100V
Input Impedance	>200k Ω
Filter Characteristics	Low pass, -3dB @ 60Hz
PLC Data Format	16-bit, Unsigned Integer, 0–FFFF (binary) or 0–65535 (BCD) [*]
Sample Duration Time	10.2 ms
All Channel Update Rate	81.6 ms
Conversion Method	Successive Approximation
Accuracy vs. Temperature	\pm 50PPM / °C Maximum
Maximum Inaccuracy	0.2% of range (including temperature drift)
Linearity Error (End to End)	\pm 10 count maximum Monotonic with no missing codes
Input Stability and Repeatability	\pm 10 count (after 10 min. warm up)
Full Scale Calibration Error (including Offset)	\pm 10 counts maximum
Offset Calibration Error	\pm 10 count maximum
Maximum Crosstalk at DC, 50 Hz and 60 Hz	\pm 10 count maximum
External 24VDC Power Required	24VDC \pm 10% @ 25mA
Base Power Required (5.0V)	25mA

^{*} Each channel requires 2 words of V-memory irrespective of the format used.

General Specifications	
Operating Temperature	0 to 55°C (32 to 131°F)
Storage Temperature	-20 to 70°C (-4 to 158°F)
Humidity	5 to 95% (non-condensing)
Environmental air	No corrosive gases permitted (EN61131-2 pollution degree 1)
Vibration	MIL STD 810C 514.2
Shock	MIL STD 810C 516.2
Field to Logic side Isolation	1800VAC applied for 1 second (100% tested)
Insulation Resistance	>10M ohms @ 500VDC
Noise Immunity	NEMA ICS3-304; Impulse 1000V @ 1ms pulse; RFI, (145MHz, 440MHz 5W @ 15cm); Worst case error during noise disturbance is 0.5% of full scale
Agency Approvals	UL508; UL60079-15 Zone 2
Module Location	Any slot in a DL05 or DL06 System
Field Wiring	Removable Terminal Block
Weight	49g (1.7 oz.)

Setting the Module Jumpers

The position of the jumper determines the input signal voltage levels. You can choose between 0–5 VDC or 0–10 VDC. The 0–5V position is the default position. With the jumper connecting the J5 posts, an input signal level of 0–5 VDC is selected.

Select 0–10 VDC inputs by removing the jumper from the J5 posts and placing it across the J4 posts.

Locating the jumpers

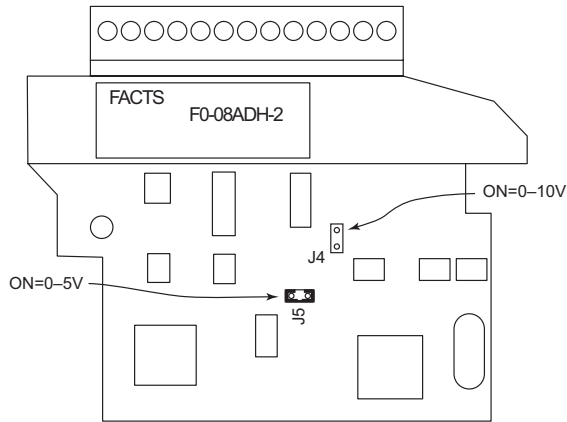

Setting the appropriate jumper

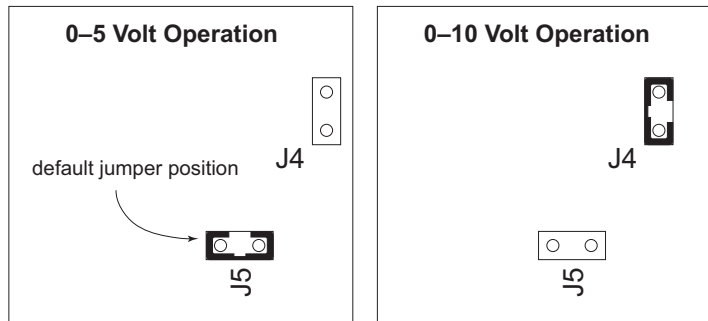

Connecting and Disconnecting the Field Wiring



WARNING: Before removing the analog module or the terminal block on the face of the module, disconnect power to the PLC and all field devices. Failure to disconnect power can result in damage to the PLC and/or field devices.

Wiring Guidelines

Your company may have guidelines for wiring and cable installation. If so, you should check those before you begin the installation. Here are some general things to consider:

- Use the shortest wiring route whenever possible.
- Use shielded wiring and ground the shield at the transmitter source. *Do not* ground the shield at both the module and the source.
- Do not run the signal wiring next to large motors, high current switches, or transformers. This may cause noise problems.
- Route the wiring through an approved cable housing to minimize the risk of accidental damage. Check local and national codes to choose the correct method for your application.

The F0-08ADH-2 does not supply power to field devices. You will need to power transmitters separately from the PLC.

To remove the terminal block, disconnect power to the PLC and the field devices. Pull the terminal block firmly until the connector separates from the module.

You can remove the analog module from the PLC by folding out the retaining tabs at the top and bottom of the module. As the retaining tabs pivot upward and outward, the module's connector is lifted out of the PLC socket. Once the connector is free, you can lift the module out of its slot.

Terminal Block Specifications	
Number of Positions	13
Re-Order Number	D0-ACC-4
Pitch	0.2 inch (5.08 mm)
Wire Range	28-16AWG Solid or Stranded Conductor; Wire strip length 5/16" (7-8 mm)
Screwdriver Size (Slotted)	0.4T x 2.5W mm (part number DN-SS1)
Screw Size	M2.5 size
Screw Torque	4.5 inch-pounds (0.52 N·m)

Wiring Diagram

Use the following diagram to connect the field wiring. If necessary, the F0-08ADH-2 terminal block can be removed to make removal of the module possible without disturbing field wiring.

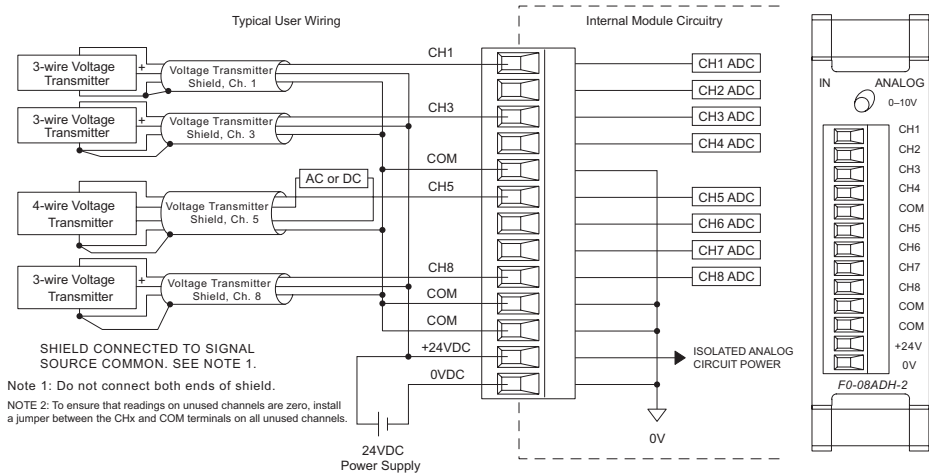

Module Operation

Channel Scanning Sequence

The DL05 and DL06 will read all eight channels of input data during each scan. Each CPU supports special V-memory locations that are used to manage the data transfer. This is discussed in more detail beginning in the section on “Special V-memory Locations”.

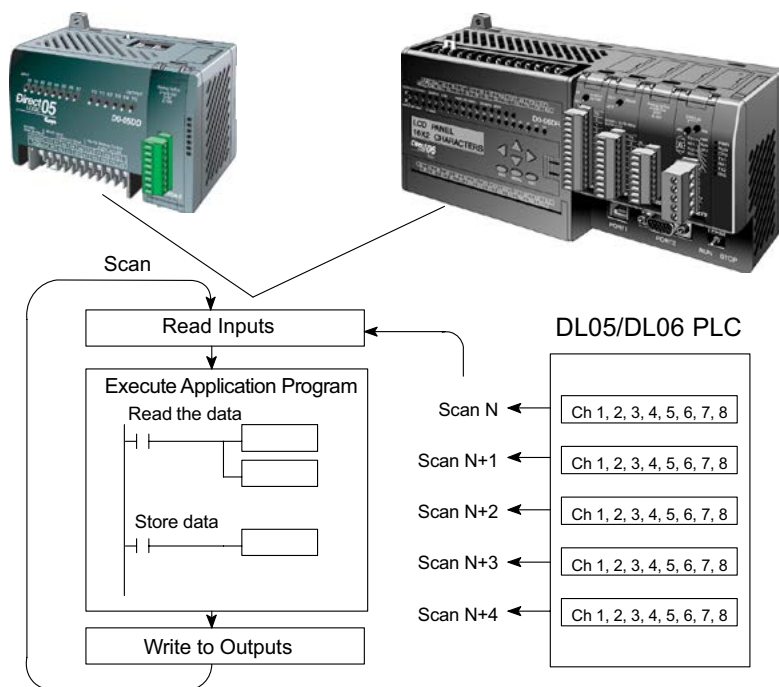

Analog Module Updates

Even though the channel updates to the CPUs are synchronous with the CPU scan, the module asynchronously monitors the analog transmitter signals and converts each signal into a 16-bit binary representation. This enables the module to continuously provide accurate measurements without slowing down the discrete control logic in the RLL program.

The module takes approximately 10.2 milliseconds to sense 95% of the change in the analog signal per channel. It takes approximately 81.6 ms to sample all channels.



NOTE: If you are comparing other manufacturers' update times (step responses) with ours, please be aware that some manufacturers refer to the time it takes to convert the analog signal to a digital value. Our analog to digital conversion takes only a few microseconds. It is the settling time of the filter that is critical in determining the full update time. Our update time specification includes the filter settling time.

Special V-memory Locations

Formatting the Analog Module Data

The DL05 and DL06 PLCs have special V-memory locations assigned to their respective option slots. These V-memory locations allow you to:

- Specify the data format (binary or BCD)
- Specify the number of channels to scan (up to 8 channels for the F0-08ADH-2)
- Specify the V-memory locations to store the input data

DL05 Data Formatting

The table below shows the special V-memory locations used by the DL05 PLC for the F0-08ADH-2.

Analog Input Module DL05 Special V-memory Locations	
Data Type and Number of Channels	V7700
Storage Pointer	V7701

Setup Data Type and Number of Active Channels

V-memory location 7700 is used to set the data format to either BCD or binary and to set the number of channels that will be active.

For example, assume the F0-08ADH-2 is installed in the option slot. Loading a constant of 800 into V7700 sets 8 channels active and causes the input data value to be read as a BCD number.

With the F0-08ADH-2 in the option slot, loading a constant of 8800 into V7700 sets 8 channels active, and the input data value is read as a binary number.

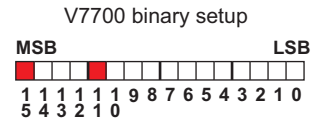
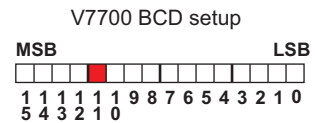

Storage Pointer Setup

V7701 is a system V-memory location used as a pointer to a user V-memory location where the analog input data is stored. The V-memory location loaded into V7701 is an octal number identifying the first user V-memory location for reading the analog input data. This V-memory location is user selectable. For example, loading O2000 causes the pointer to write Ch 1's data value to V2000 – 2001, Ch 2's data value to V2002 – 2003, Ch 3's data value to V2004 – 2005, Ch 4's data value to V2006 – 2007, Ch 5's data value to V2010 – 2011, Ch 6's data value to V2012 – 2013, Ch 7's data value to V2014 – 2015, and Ch 8's data value to V2016 – 2017.

You will find an example program that loads appropriate values to V7700 and V7701 on page 6-10.

DL06 Data Formatting

Special V-memory locations are assigned to the four option slots of the DL06 PLC. The table below shows these V-memory locations which can be used to setup the F0-08ADH-2.

Analog Input Module DL06 Special V-memory Locations				
Slot No.	1	2	3	4
Data Type and Number of Channels	V700	V710	V720	V730
Storage Pointer	V701	V711	V721	V731

Setup Data Type and Number of Active Channels

V-memory locations 700, 710, 720, and 730 are used to set the data format to either BCD or binary and to set the number of channels that will be active.

For example, assume the F0-08ADH-2 is installed in slot 1. Loading a constant of 800 into V700 sets 8 channels active and causes the input data value to be read as a BCD number.

With the F0-08ADH-2 in slot 1, loading a constant of 8800 into V700 sets 8 channels active, and the input data value is read as a binary number.

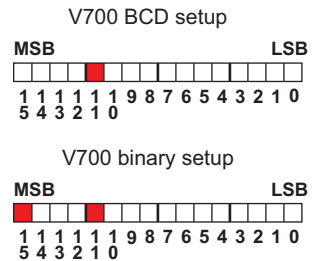

Storage Pointer Setup

V-memory locations 701, 711, 721 and 731 are special locations used as storage pointers. A V-memory address is loaded into this location as an octal number identifying the first user V-memory location for the analog input data. This V-memory location is user selectable. For example, loading O2000 causes the pointer to write Ch 1's data value to V2000 – 2001, Ch 2's data value to V2002 – 2003, Ch 3's data value to V2004 – 2005, Ch 4's data value to V2006 – 2007, Ch 5's data value to V2010 – 2011, Ch 6's data value to V2012 – 2013, Ch 7's data value to V2014 – 2015, and Ch 8's data value to V2016 – 2017.

You will find an example program that loads appropriate values to V700 and V701 beginning on page 6-10.

Using the Pointer in Your Control Program

DL05 Pointer Method Using Conventional Ladder Logic



NOTE: The proper use of the DL05 pointer requires that the V-memory address be written to the special memory location on the first scan only. Use the SP0 bit as a permissive contact when using the code shown below.

The example program below shows how to setup these locations. This rung can be placed anywhere in the ladder program or in the initial stage if you are using stage programming instructions.

This is all that is required to read the analog input data into V-memory locations. Once the data is in V-memory you can perform math on the data, compare the data against preset values, and so forth. V2000 is used in the example but you can use any user V-memory location.

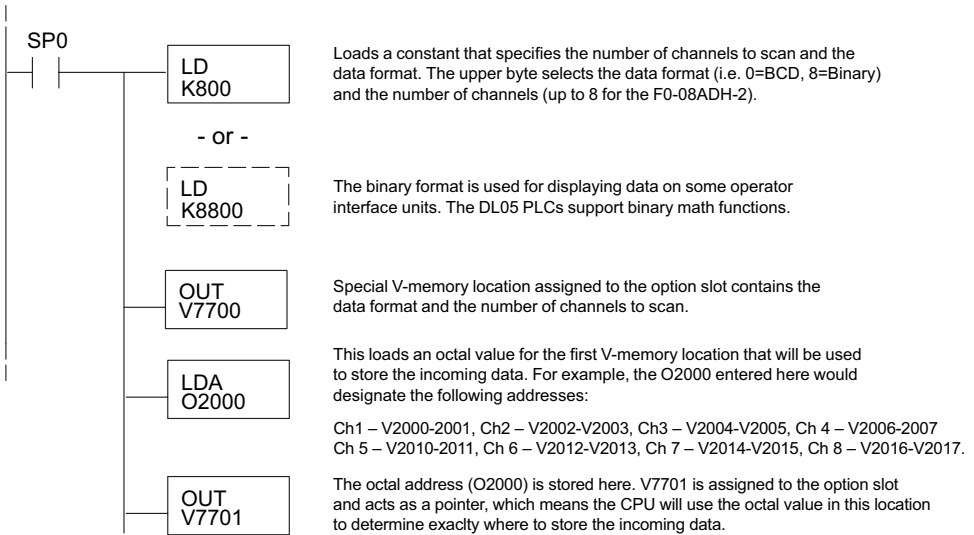

DL05 Pointer Method Using the IBox Instruction Available in DirectSOFT5

The following logic accomplishes the same thing as the previous ladder example, but it uses the IBox instruction ANLGIN.

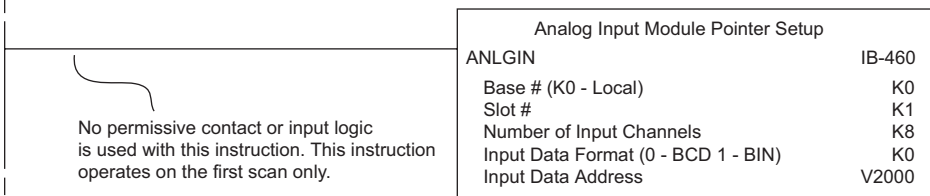

DL06 Pointer Method Using Conventional Ladder Logic



NOTE: The proper use of the DL06 pointer requires that the V-memory address be written to the special memory location on the first scan only. Use the SP0 bit as a permissive contact when using the code shown below.

Analog Input Module DL06 Special V-memory Locations				
Slot No.	1	2	3	4
No. of Channels	V700	V710	V720	V730
Input Pointer	V701	V711	V721	V731

Use the special V-memory table below as a guide to setup the storage pointer in the following example for the DL06. Slot 1 is the left most option slot.

The F0-08ADH-2 can be installed in any available DL06 option slot. The ladder diagram below shows how to set up these locations with the module installed in slot 1 of the DL06. Use the above table to determine the pointer values if locating the module in any of the other slot locations. Place this rung anywhere in the ladder program or in the initial stage if you are using stage programming instructions.

This logic is all that is required to read the analog input data into V-memory locations. Once the data is in V-memory you can perform mathematical calculations with the data, compare the data against preset values, and so forth. In the example, V2000 is used, but you can use any user V-memory location.

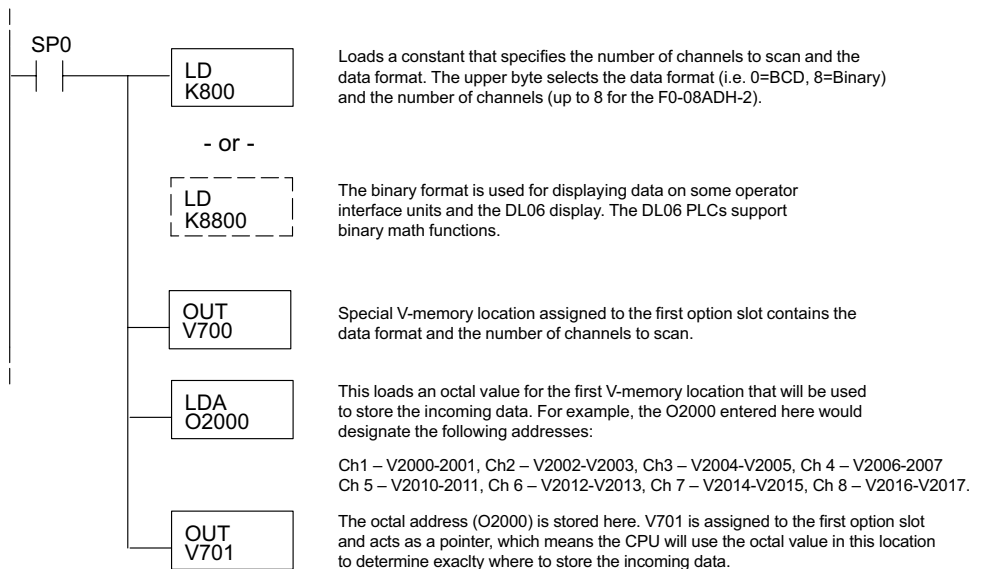

DL06 Pointer Method Using the IBox Instruction Available in DirectSOFT5

The following logic accomplishes the same thing as the previous ladder example, but it uses the IBox instruction ANLGIN.

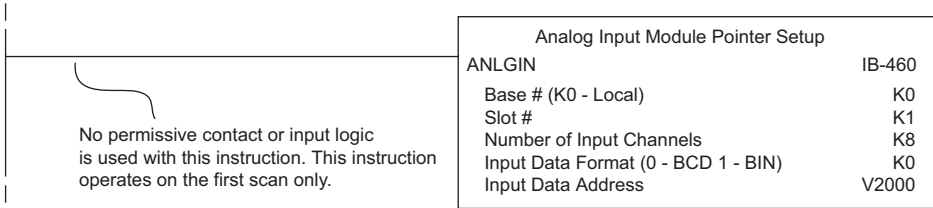

Conversions

Scaling the Input Data

Many applications call for measurements in engineering units, which can be more meaningful than raw data. Convert to engineering units using the formula shown to the right.

You may have to make adjustments to the formula depending on the scale you choose for the engineering units.

For example, if you wanted to measure pressure (PSI) from 0.0 to 99.9 then you would have to multiply the analog value by 10 in order to imply a decimal place when you view the value with the programming software or a handheld programmer. Notice how the calculations differ when you use the multiplier.

Analog Value of 32375, slightly less than half scale, should yield 49.4 PSI.

$$\text{Units} = A \frac{H - L}{65535} + L$$

H = High limit of the engineering unit range
 L = Low limit of the engineering unit range
 A = Analog value (0 – 65535)

Example without multiplier	Example with multiplier
Units = A $\frac{H - L}{65535} + L$	Units = 10 x A $\frac{H - L}{65535} + L$
Units = 32375 $\frac{100 - 0}{65535} + 0$	Units = 323750 $\frac{100 - 0}{65535} + 0$
Units = 49	Units = 494

The Conversion Program in Standard Ladder Logic

The following example shows how you would write the program to perform the engineering unit conversion. This example assumes you have BCD data loaded into the appropriate V-memory locations using instructions that apply for the model of CPU you are using.

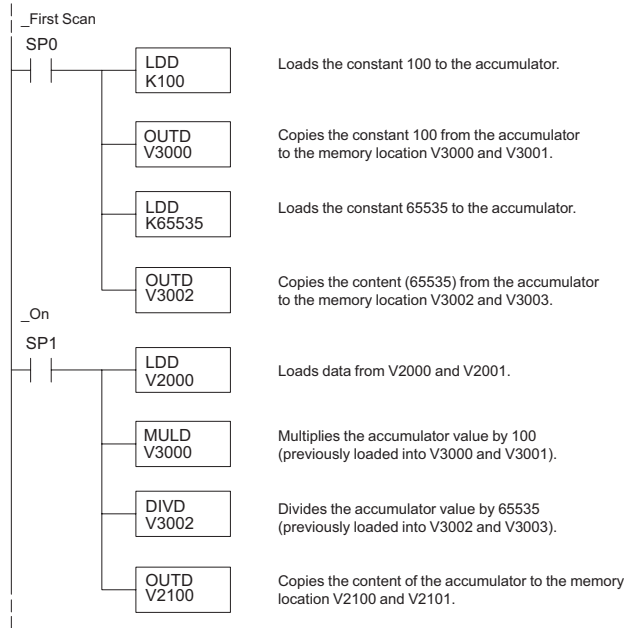

Analog and Digital Value Conversions

Sometimes it is useful to convert between the signal levels and the digital values. This is especially helpful during machine start-up or troubleshooting. The following table provides formulas to make this conversion easier.

Range	If you know the digital value	If you know the analog signal level
0 to 5V	$A = \frac{5}{65535} \cdot D$	$D = \frac{65535}{5} \cdot A$
0 to 10V	$A = \frac{10}{65535} \cdot D$	$D = \frac{65535}{10} \cdot A$

For example, if you have measured the signal as 6V, you can use the formula to determine the digital value that will be stored in V-memory location that contains the data.

$$D = \frac{65535}{10} \cdot A$$

$$D = \frac{65535}{10} \cdot 6V$$

$$D = 39321$$

Module Resolution

Analog Data Bits

Two 16-bit words are reserved for the analog data whether you are using BCD or binary data formatting. The 16 bits in the low word represent the analog data in binary format.

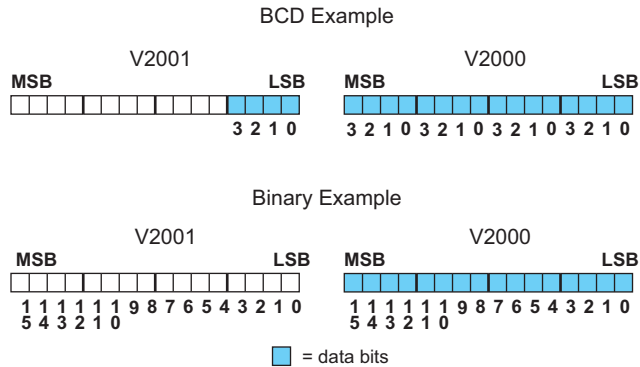

Resolution Details

Since the module has 16-bit resolution, the analog signal is converted into 65,536 counts ranging from 0 - 65,535 (2^{16}). For example, with a 10V range, a 0V signal would be 0 and a 10V signal would be 65535. This is equivalent to a binary value of 0000 0000 0000 0000 to 1111 1111 1111 1111, or 000 to FFFF hexadecimal.

Each count can also be expressed in terms of the signal level by using the following equation:

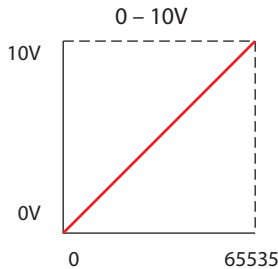

$$\text{Resolution} = \frac{H - L}{65535}$$

H = high limit of the signal range

L = low limit of the signal range

The following table shows the smallest detectable signal change that will result in one LSB change in the data value for each increment of the signal change.

mA Range	Signal Span (H - L)	Divide By	Smallest Detectable Change
0 to 5V	5 volts	65535	0.07630 mV
0 to 10V	10 volts	65535	0.15259 mV

Analog Input Ladder Logic Filter

PID Loops / Filtering

Please refer to the “PID Loop Operation” chapter in the DL06 or DL05 User Manual for information on the built-in PV filter (DL05/06) and the ladder logic filter (DL06 only) shown below. A filter must be used to smooth the analog input value when auto tuning PID loops to prevent giving a false indication of loop characteristics.

Smoothing the Input Signal (DL06 only)

The filter logic can also be used in the same way to smooth the analog input signal to help stabilize PID loop operation or to stabilize the analog input signal value for use with an operator interface display, etc.



WARNING: The built-in and logic filters are not intended to smooth or filter noise generated by improper field device wiring or grounding. Small amounts of electrical noise can cause the input signal to bounce considerably. Proper field device wiring and grounding must be done before attempting to use the filters to smooth the analog input signal.

Binary Data Format Filter Using Ladder Logic

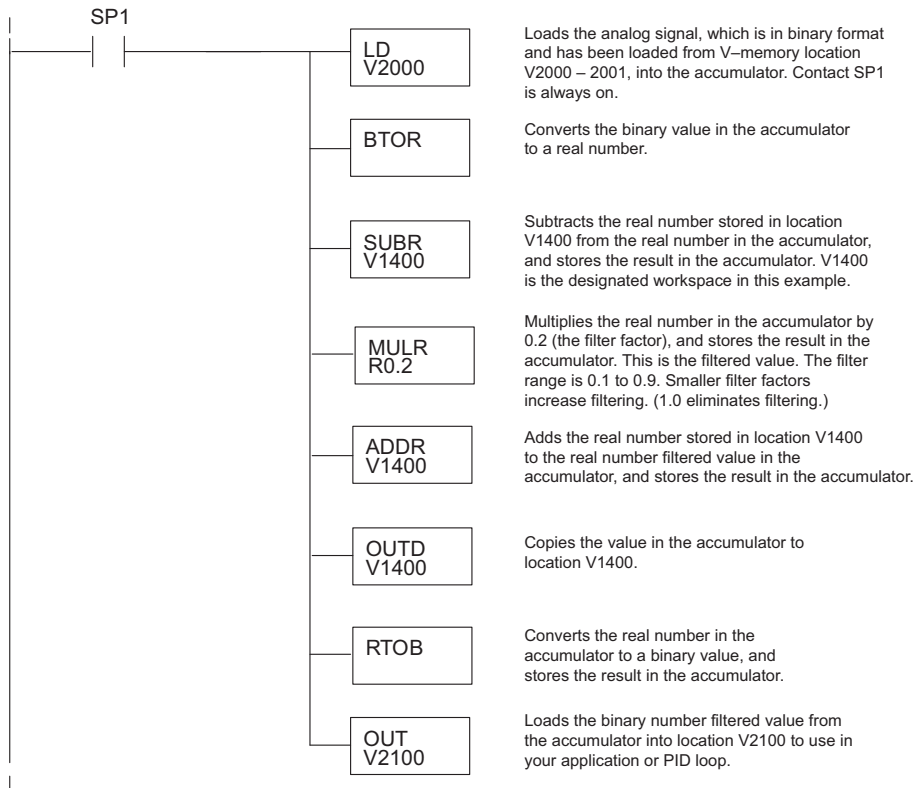



NOTE: Be careful not to do a multiple number conversion on a value. For example, if you are using the pointer method in BCD format to get the analog value, it must be converted to binary (BIN) as shown below. If you are using the pointer method in Binary format, the conversion to binary (BIN) instruction is not needed.

Using BCD Data Format

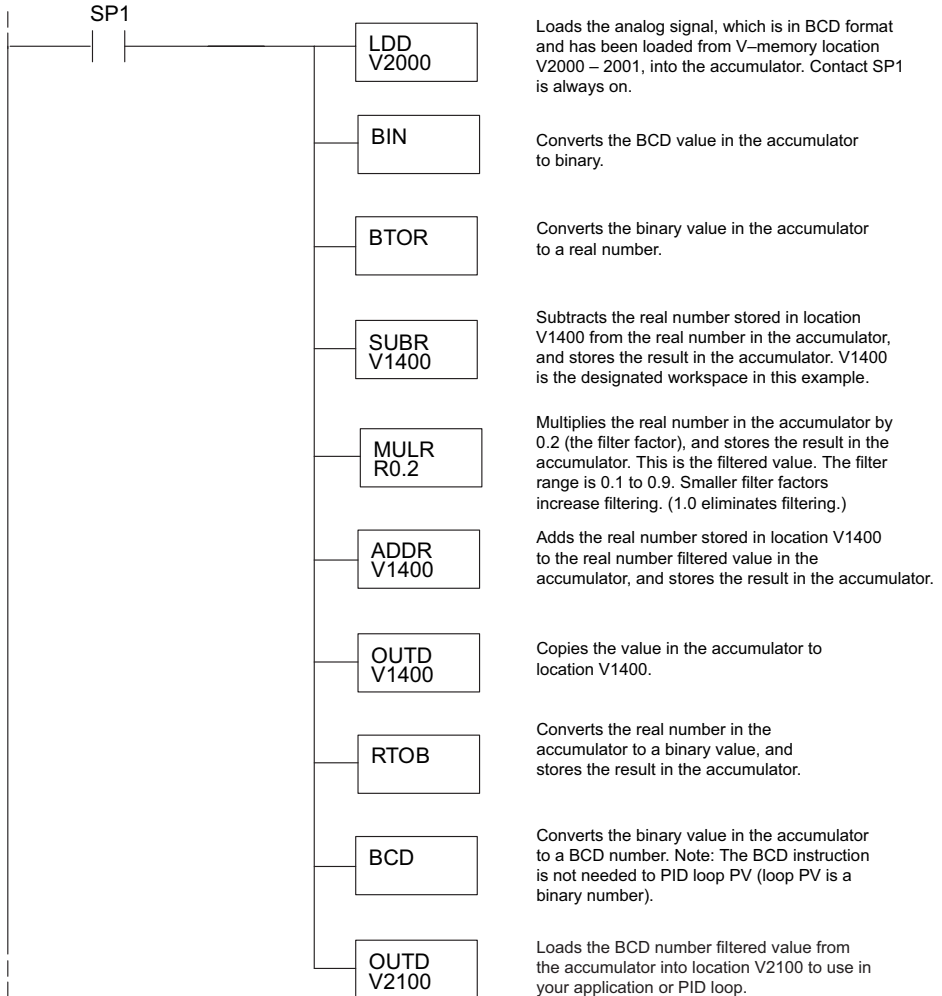

F0-04DAH-1, 4-CHANNEL ANALOG CURRENT OUTPUT



In This Chapter...

Module Specifications	7-2
Connecting and Disconnecting the Field Wiring	7-4
Wiring Diagram	7-5
Module Operation	7-6
Special V-memory Locations	7-7
Using the Pointer in Your Control Program	7-9
Output Scale Conversion.....	7-11
Module Resolution.....	7-14

Module Specifications

The F0-04DAH-1 analog output module offers the following features:

- Full 16-bit resolution.
- The DL05 and DL06 will update all four channels in one scan.
- The removable terminal block simplifies module replacement.

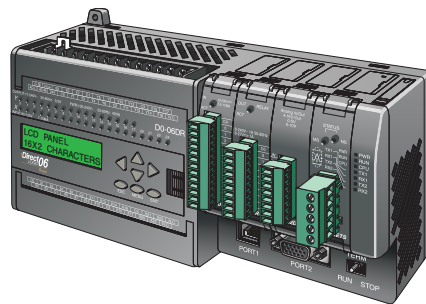

NOTE: The DL05 CPU's analog feature for this module requires **DirectSOFT32** Version 3.0c (or later) and firmware version 5.20 (or later). The DL06 requires **DirectSOFT32** version V4.0, build 16 (or later) and firmware version 2.30 (or later). See our website for more information: www.automationdirect.com.

The following tables provide the specifications for the F0-04DAH-1 Analog Output Module. Review these specifications to make sure the module meets your application requirements.

Output Specifications	
Outputs per module	4
Output Range	4–20 mA
Resolution	16-bit, 0.244 μ A/bit
Output Type	Current sourcing at 20mA max.
PLC Data Format	16-bit, Unsigned Integer, 0–FFFF (binary) or 0–65535 (BCD) ¹
Output value in program mode	4mA (excluding PID, independent mode)
Load Impedance	250–750 Ohms
Maximum Inductive Load	1mH
Maximum Inaccuracy	0.2% of range
Maximum Full Scale Calibration Error (not including offset error)	\pm 0.025% of range maximum
Maximum Offset Calibration Error	\pm 0.025% of range maximum
Accuracy vs. Temperature	\pm 50 ppm/ $^{\circ}$ C maximum full scale calibration change
Maximum Crosstalk	\pm 10 counts
Linearity Error (End to End)	\pm 16 count maximum (\pm 0.025% of full scale) Monotonic with no missing codes
Output Stability and Repeatability	\pm 10 LSB after 10 min. warm-up typical
Output Ripple	0.05% of Full Scale
Output Settling Time	0.5 ms maximum, 5 μ s minimum (full scale change)
All Channel Update Rate	100 μ s
Maximum Continuous Overload	Outputs open circuit protected
Type of Output Protection	Electronically current limited to 20mA or less
Output signal at power-up and power-down	4mA
External 24VDC Power Required	24VDC \pm 10% @ 150mA
Base Power Required (5.0V)	25mA

¹Each channel requires 2 words of V-memory irrespective of the format used.

General Specifications	
Operating Temperature	0 to 55 $^{\circ}$ C (32 to 131 $^{\circ}$ F)
Storage Temperature	-20 to 70 $^{\circ}$ C (-4 to 158 $^{\circ}$ F)
Humidity	5 to 95% (non-condensing)
Environmental air	No corrosive gases permitted (EN61131-2 pollution degree 1)
Vibration	MIL STD 810C 514.2
Shock	MIL STD 810C 516.2
Field to Logic side Isolation	1800VAC applied for 1 second (100% tested)
Insulation Resistance	>10M ohms @ 500VDC
Noise Immunity	NEMA ICS3-304; Impulse 1000V @ 1mS pulse; RFI, (145MHz, 440Mhz 5W @ 15cm); Worst case error during noise disturbance is 0.5% of full scale
Agency Approvals	UL508; UL60079-15 Zone 2
Module Location	Any slot in a DL05 or DL06 System
Field Wiring	Removable Terminal Block
Weight	49g (1.7 oz.)

Connecting and Disconnecting the Field Wiring



WARNING: Before removing the analog module or the terminal block on the face of the module, disconnect power to the PLC and all field devices. Failure to disconnect power can result in damage to the PLC and/or field devices.

Wiring Guidelines

Your company may have guidelines for wiring and cable installation. If so, you should check those before you begin the installation. Here are some general things to consider:

- Use the shortest wiring route whenever possible.
- Use shielded wiring and ground the shield at the transmitter source. *Do not* ground the shield at both the module and the source.
- Do not run the signal wiring next to large motors, high current switches, or transformers. This may cause noise problems.
- Route the wiring through an approved cable housing to minimize the risk of accidental damage. Check local and national codes to choose the correct method for your application.

The F0-04DAH-1 does not supply power to field devices. You will need to power transmitters separately from the PLC.

To remove the terminal block, disconnect power to the PLC and the field devices. Pull the terminal block firmly until the connector separates from the module.

You can remove the analog module from the PLC by folding out the retaining tabs at the top and bottom of the module. As the retaining tabs pivot upward and outward, the module's connector is lifted out of the PLC socket. Once the connector is free, you can lift the module out of its slot.

Terminal Block Specifications	
Number of Positions	13
Re-Order Number	D0-ACC-4
Pitch	0.2 inch (5.08 mm)
Wire Range	28-16AWG Solid or Stranded Conductor; Wire strip length 5/16" (7-8 mm)
Screwdriver Size (Slotted)	0.4T x 2.5W mm (part number DN-SS1)
Screw Size	M2.5 size
Screw Torque	4.5 inch-pounds (0.52 N-m)

Wiring Diagram

Use the following diagram to connect the field wiring. If necessary, the F0-04DAH-1 terminal block can be removed to make removal of the module possible without disturbing field wiring.

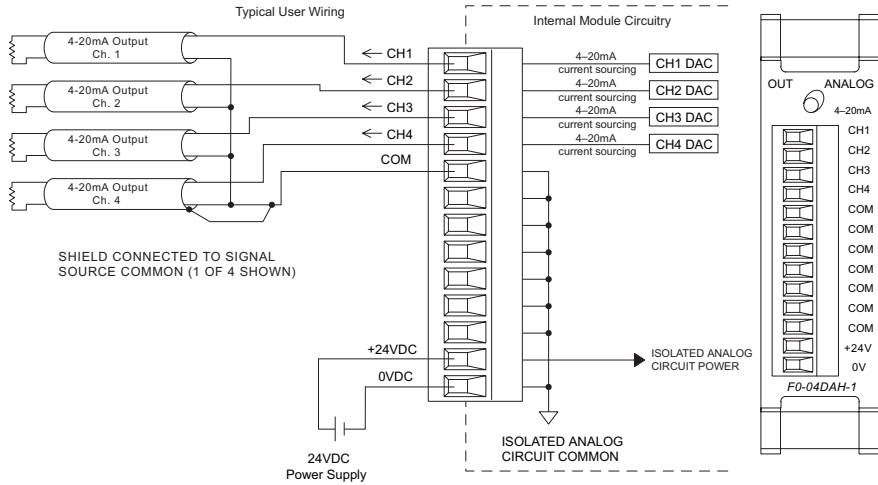

Module Operation

Channel Scanning Sequence

The DL05 and DL06 will write all four channels of output data during each scan. Each CPU supports special V-memory locations that are used to manage the data transfer. This is discussed in more detail beginning in the section on “Special V-memory Locations.”

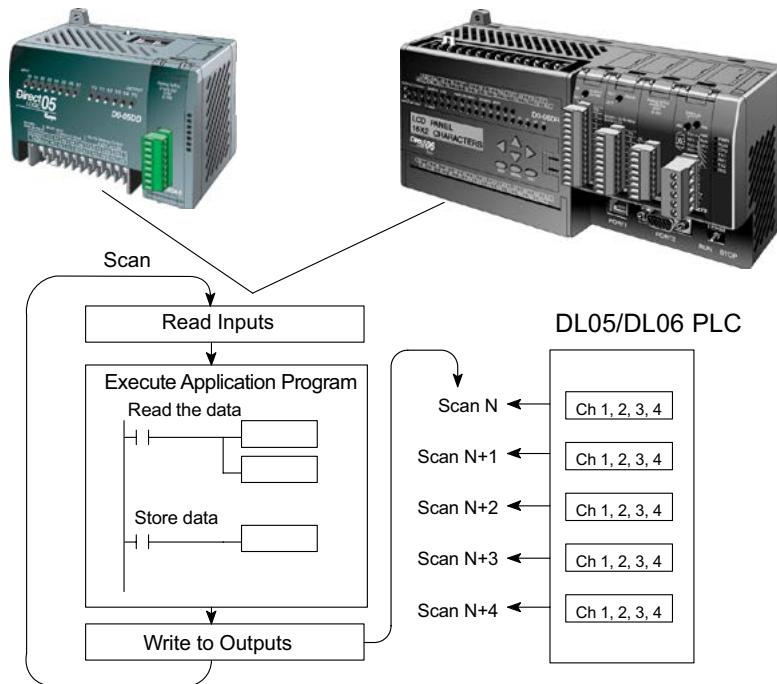

Special V-memory Locations

Formatting the Analog Module Data

The DL05 and DL06 PLCs have special V-memory locations assigned to their respective option slots. These V-memory locations allow you to:

- Specify the data format (binary or BCD)
- Specify the number of channels to update (up to 4 channels for the F0-04DAH-1)
- Specify the V-memory locations where the user program will store the output data pending distribution to the output module

DL05 Data Formatting

The table below shows the special V-memory locations used by the DL05 PLC for the F0-04DAH-1.

Analog Output Module DL05 Special V-memory Locations	
Data Type and Number of Channels	V7700
Storage Pointer	V7702

Data Type and Number of Active Channels Setup

System memory location V7700 is used to set the data format either to BCD or binary and to set the number of channels that will be active.

For example, loading a constant of 0004 (BCD) into V7700 sets four channels active and causes the output data value to be read from pointer-designated V-memory as a BCD number.

Alternatively, loading a constant of 0084 (BCD) into V7700 sets four channels active and causes the output data value to be read from pointer-designated V-memory as a binary number.

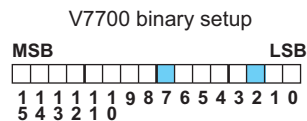
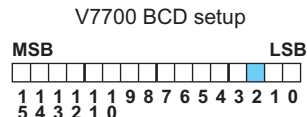

Storage Pointer Setup

System memory location V7702 is used as a pointer. It points to a user memory location where the analog output data is stored by the user program, pending distribution to the output module. An octal number is loaded to the pointer memory to identify the beginning of a block of user memory where output values are stored.

For example, loading O2100 into V7702 causes the CPU to look for Ch 1's output data value in V2100 – 2101, Ch 2's data value in V2102 – 2103, Ch 3's data value in V2104 – 2105, and Ch 4's data value in V2106 – 2107.

You will find an example program that loads appropriate values to V7700 and V7702 on page 7-9.

DL06 Data Formatting

Special V-memory locations are assigned to the four option slots of the DL06 PLC. The table below shows these V-memory locations which can be used to setup the F0-04DAH-1.

Analog Output Module DL06 Special V-memory Locations				
Slot No.	1	2	3	4
Data Type and Number of Channels	V700	V710	V720	V730
Output Pointer	V702	V712	V722	V732

Data Type and Number of Active Channels Setup

System memory locations V700, 710, 720, and 730 are used to set the data format either to BCD or binary and to set the number of channels that will be active.

For example, loading a constant of 0004 (BCD) into V700 sets four channels active and causes the output data value to be read from pointer-designated V-memory as a BCD number.

Alternatively, loading a constant of 0084 (BCD) into V700 sets four channels active and causes the output data value to be read from pointer-designated V-memory as a binary number.

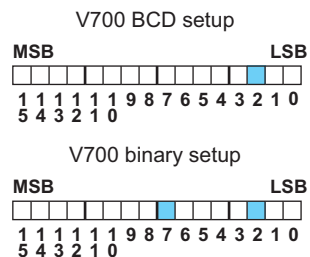

Storage Pointer Setup

System memory locations V702, 712, 722, and 732 are used as pointers. They point to user memory locations where the analog output data is stored by the user program, pending distribution to the output module. An octal number is loaded to the pointer memory to identify the beginning of a block of user memory where output values are stored.

For example, loading O2100 into V702 causes the CPU to look for Ch 1's output data value in V2100 – 2101, Ch 2's data value in V2102 – 2103, Ch 3's data value in V2104 – 2105, and Ch 4's data value in V2106 – 2107.

You will find an example program that loads appropriate values to V7700 and V7702 on page 7-10.

Using the Pointer in Your Control Program

DL05 Pointer Method Using Conventional Ladder Logic



NOTE: The proper use of the DL05 pointer requires that the V-memory address be written to the special memory location on the first scan only. Use the SPO bit as a permissive contact when using the code shown below.

The example program below shows how to setup the special V-memory locations. This rung can be placed anywhere in the ladder program or in the initial stage if you are using stage programming instructions.

This is all that is required to read the analog output data from V-memory locations. In the example, V2100 is used, but you can use any user V-memory location.

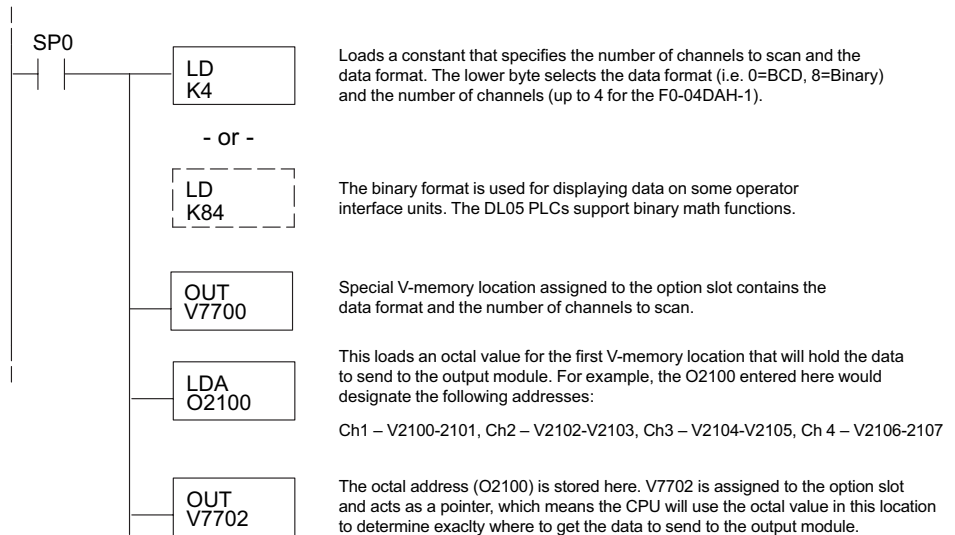

DL05 Pointer Method Using the IBox Instruction Available in DirectSOFT5

The following logic accomplishes the same thing as the previous ladder example, but it uses the IBox instruction ANLGOUT.

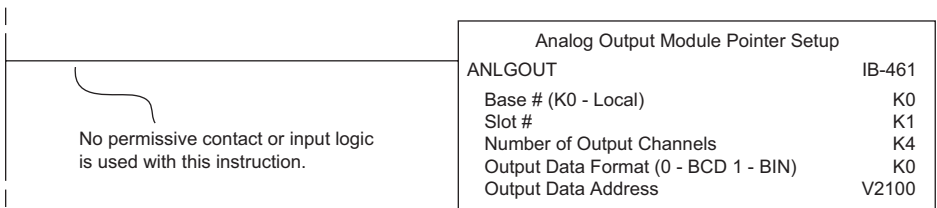

DL06 Pointer Method Using Conventional Ladder Logic



NOTE: The proper use of the DL06 pointer requires that the V-memory address be written to the special memory location on the first scan only. Use the SPO bit as a permissive contact when using the code shown below.

Analog Output Module DL06 Special V-memory Locations				
Slot No.	1	2	3	4
No. of Channels	V700	V710	V720	V730
Output Pointer	V702	V712	V722	V732

Use the special V-memory table below as a guide to setup the storage pointer in the following example for the DL06. Slot 1 is the left most option slot.

The F0-04DAH-1 can be installed in any available DL06 option slot. The ladder diagram below shows how to setup these locations with the module installed in slot 1 of the DL06. Use the above table to determine the pointer values if locating the module in any of the other slot locations. Place this rung anywhere in the ladder program or in the initial stage if you are using stage programming instructions.

This logic is all that is required to write the analog output data from V-memory locations. In the example, V2100 is used, but you can use any user V-memory location.

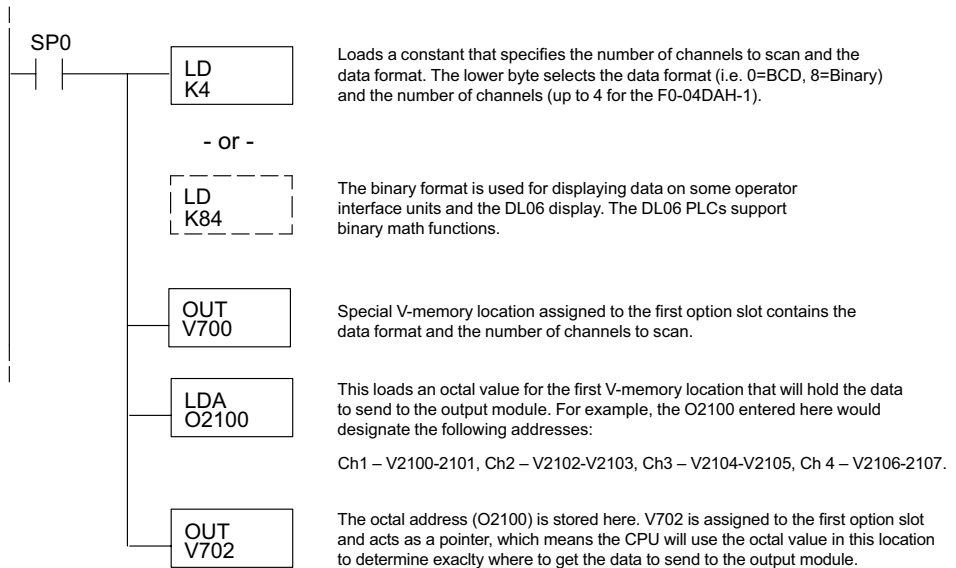

DL06 Pointer Method Using the IBox Instruction Available in DirectSOFT5

The following logic accomplishes the same thing as the previous ladder example, but it uses the IBox instruction ANLGOUT.

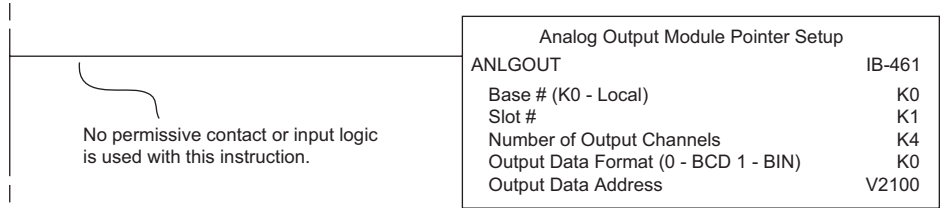

Output Scale Conversion

Calculating the Digital Output Value

Your program has to calculate the digital value to send to the analog output module. Most applications use measurements in engineering units, so it is usually necessary to convert from engineering units to a suitable output value. The conversion to an output value can be accomplished by using the conversion formula shown.

You will need to substitute the engineering units for your scale into the formula to the right.

For example, if you want to output pressure (PSI) between 0.0 and 100.0, you may multiply the pressure value by 10 to store in a V-memory location and eliminate the decimal point. Notice how the calculations differ when you use the multiplier.

The following example demonstrates how to output 49.4 PSI.

$$A = \frac{U - L}{H - L} \cdot 65535$$

U = Engineering units to output

H = High limit of the engineering unit range

L = Low limit of the engineering unit range

A = Analog value (0 – 65535)

Example without multiplier	Example with multiplier
$A = \frac{U - L}{H - L} \cdot 65535$	$A = \frac{U - L}{H - L} \cdot 65535$
$A = \frac{49 - 0}{100 - 0} \cdot 65535$	$A = \frac{494 - 0}{1000 - 0} \cdot 65535$
A = 32112	A = 32374

The Conversion Program in Standard Ladder Logic

The following example shows how you would write the program to perform the engineering unit conversion. This example assumes you have BCD data loaded into the appropriate V-memory locations using instructions that apply for the model of CPU you are using.

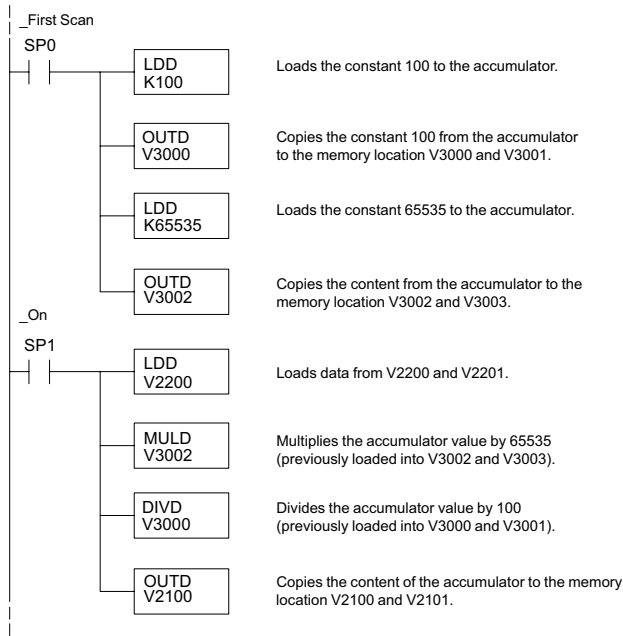

Analog and Digital Value Conversions

Sometimes it is useful to convert between the signal levels and the digital values. This is especially helpful during machine startup or troubleshooting. The following table provides formulas to make this conversion easier.

The formulas in the table show the relationship between A, the analog value, and D, the digital value.

Range	If you know the digital value	If you know the analog signal level
4 to 20 mA	$A = \left(\frac{16}{65535} \cdot D \right) + 4\text{mA}$	$D = \frac{65535}{16} \cdot (A - 4\text{mA})$

For example, if you need a 10mA signal to achieve the desired result, you can use the formula to determine the digital value that should be used.

$$D = \frac{65535}{16} \cdot (A - 4\text{mA})$$

$$D = \frac{65535}{16} \cdot (10\text{mA} - 4\text{mA})$$

$$D = 24576$$

Module Resolution

Analog Data Bits

Two 16-bit words are reserved for the analog data whether you are using BCD or binary data formatting. The 16 bits in the low word represent the analog data in binary format.

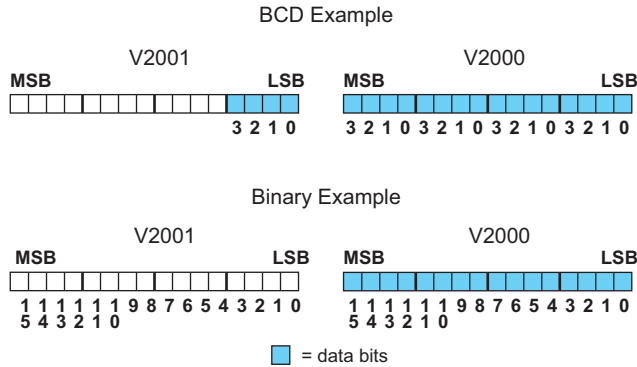

Resolution Details

Since the module has 16-bit resolution, the analog signal is converted into 65,536 counts ranging from 0 - 65,535 (2^{16}). A 4mA signal would be 0 and a 20mA signal would be 65535. This is equivalent to a binary value of 0000 0000 0000 0000 to 1111 1111 1111 1111, or 000 to FFFF hexadecimal.

Each count can also be expressed in terms of the signal level by using the following equation:

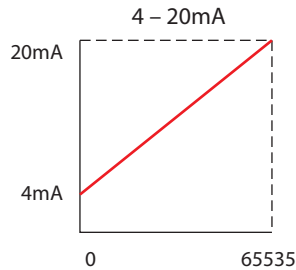

$$\text{Resolution} = \frac{H - L}{65535}$$

H = high limit of the signal range

L = low limit of the signal range

The following table shows the smallest detectable signal change that will result in one LSB change in the data value for each increment of the signal change.

mA Range	Signal Span (H - L)	Divide By	Smallest Detectable Change
4 to 20mA	16mA	65535	0.244 μ A

F0-08DAH-1, 8-CHANNEL ANALOG CURRENT OUTPUT



In This Chapter...

Module Specifications	8-2
Connecting and Disconnecting the Field Wiring	8-4
Wiring Diagram	8-5
Module Operation	8-6
Special System V-memory Locations.....	8-7
Using the Pointer in Your Control Program	8-9
Output Scale Conversion.....	8-11
Module Resolution.....	8-14

Module Specifications

The F0-08DAH-1 analog output module offers the following features:

- The DL05 and DL06 will update all eight channels in one scan.
- The removable terminal block simplifies module replacement.
- Full 16-bit resolution.

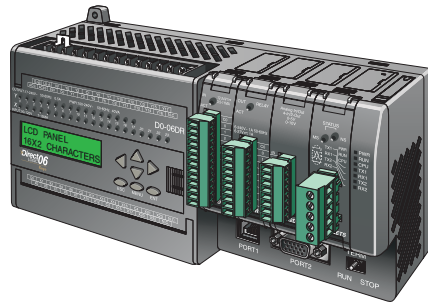

NOTE: The DL05 CPU's analog feature for this module requires **DirectSOFT32** Version 3.0c (or later) and firmware version 5.20 (or later). The DL06 requires **DirectSOFT32** version V4.0, build 16 (or later) and firmware version 2.30 (or later). See our website for more information: www.automationdirect.com.

The following tables provide the specifications for the F0-08DAH-1 Analog Output Module. Review these specifications to make sure the module meets your application requirements.

Output Specifications	
Outputs per module	8
Output Range	4–20 mA
Resolution	16-bit, 0.244 μ A/bit
Output Type	Current sourcing at 20mA max.
PLC Data Format	16-bit, Unsigned Integer, 0–FFFF (binary) or 0–65535 (BCD)
Output value in program mode	4mA (excluding PID, independent mode)
Load Impedance	250–750 Ohms
Maximum Inductive Load	1mH
Maximum Inaccuracy	0.2% of range
Maximum Full Scale Calibration Error (not including offset error)	\pm 0.025% of range maximum
Maximum Offset Calibration Error	\pm 0.025% of range maximum
Accuracy vs. Temperature	\pm 50ppm / °C maximum full scale calibration change
Maximum Crosstalk	\pm 10 counts
Linearity Error (End to End)	\pm 16 count maximum (\pm 0.025% of full scale) Monotonic with no missing codes
Output Stability and Repeatability	\pm 10 counts after 10 min. warm-up typical
Output Ripple	0.05% of Full Scale
Output Settling Time	0.5 ms maximum, 5 μ s minimum (full scale change)
All Channel Update Rate	100us
Maximum Continuous Overload	Outputs open circuit protected
Type of Output Protection	Electronically current limited to 20mA or less
Output signal at power-up and power-down	4mA
External 24VDC Power Required	24VDC \pm 10% @ 220mA
Base Power Required (5.0 V)	25mA

[†]Each channel requires 2 words of V-memory irrespective of the format used.

General Specifications	
Operating Temperature	0 to 55°C (32 to 131°F)
Storage Temperature	-20 to 70°C (-4 to 158°F)
Humidity	5 to 95% (non-condensing)
Environmental air	No corrosive gases permitted (EN61131-2 pollution degree 1)
Vibration	MIL STD 810C 514.2
Shock	MIL STD 810C 516.2
Field to Logic side Isolation	1800VAC applied for 1 second (100% tested)
Insulation Resistance	>10M ohms @ 500VDC
Noise Immunity	NEMA ICS3-304; Impulse 1000V @ 1mS pulse; RFI, (145MHz, 440Mhz 5W @ 15cm); Worst case error during noise disturbance is 0.5% of full scale
Agency Approvals	UL508; UL60079-15 Zone 2
Module Location	Any slot in a DL05 or DL06 System
Field Wiring	Removable Terminal Block
Weight	49g (1.7 oz.)

Connecting and Disconnecting the Field Wiring



WARNING: Before removing the analog module or the terminal block on the face of the module, disconnect power to the PLC and all field devices. Failure to disconnect power can result in damage to the PLC and/or field devices.

Wiring Guidelines

Your company may have guidelines for wiring and cable installation. If so, you should check those before you begin the installation. Here are some general things to consider:

- Use the shortest wiring route whenever possible.
- Use shielded wiring and ground the shield at the transmitter source. *Do not* ground the shield at both the module and the source.
- Do not run the signal wiring next to large motors, high current switches, or transformers. This may cause noise problems.
- Route the wiring through an approved cable housing to minimize the risk of accidental damage. Check local and national codes to choose the correct method for your application.

The F0-08DAH-1 does not supply power to field devices. You will need to power transmitters separately from the PLC.

To remove the terminal block, disconnect power to the PLC and the field devices. Pull the terminal block firmly until the connector separates from the module.

You can remove the analog module from the PLC by folding out the retaining tabs at the top and bottom of the module. As the retaining tabs pivot upward and outward, the module's connector is lifted out of the PLC socket. Once the connector is free, you can lift the module out of its slot.

Terminal Block Specifications	
Number of Positions	13
Re-Order Number	D0-ACC-4
Pitch	0.2 inch (5.08 mm)
Wire Range	28-16 AWG Solid or Stranded Conductor; Wire strip length 5/16" (7-8 mm)
Screwdriver Size (Slotted)	0.4T x 2.5W mm (part number DN-SS1)
Screw Size	M2.5 size
Screw Torque	4.5 inch-pounds (0.52 N-m)

Wiring Diagram

Use the following diagram to connect the field wiring. If necessary, the F0-08DAH-1 terminal block can be removed to make removal of the module possible without disturbing field wiring.

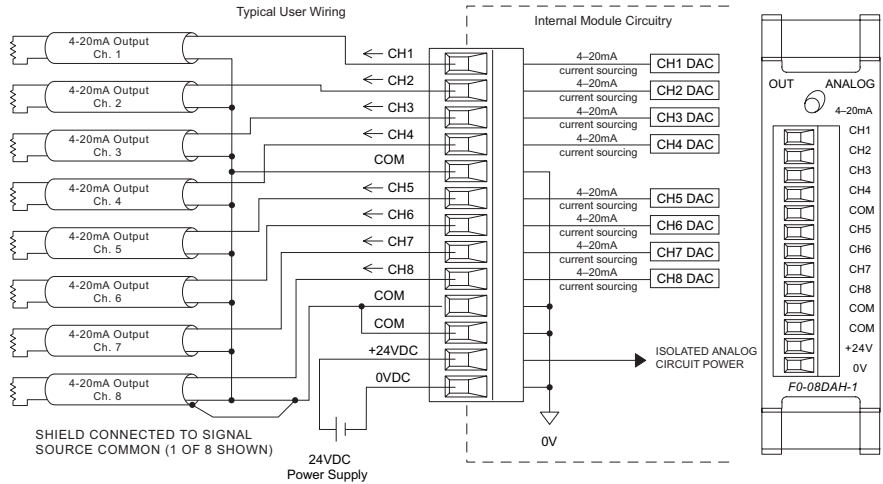

Module Operation

Channel Scanning Sequence

The DL05 and DL06 will read all eight channels of output data during each scan. Each CPU supports special V-memory locations that are used to manage the data transfer. This is discussed in more detail beginning in the section on “Special V-memory Locations”.

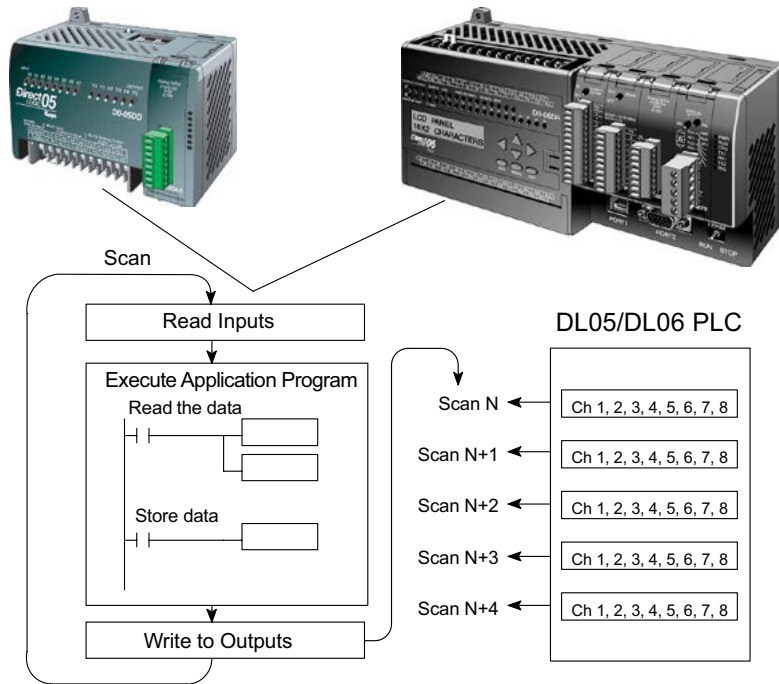

Special System V-memory Locations

Formatting the Analog Module Data

The DL05 and DL06 PLCs have system V-memory locations assigned to their respective option slots. These V-memory locations allow you to:

- Specify the data format (binary or BCD)
- Specify the number of channels to scan (up to 8 channels for the F0-08DAH-1)
- Specify the V-memory locations where the user program will store the output data pending distribution to the output module

DL05 Data Formatting

The table below shows the system V-memory locations used by the DL05 PLC for the F0-08DAH-1.

Analog Output Module DL05 Special V-memory Locations	
Data Type and Number of Channels	V7700
Storage Pointer	V7702

Data Type and Number of Active Channels Setup

System memory location V7700 is used to set the data format either to BCD or binary and to set the number of channels that will be active.

For example, loading a constant of 0008 (BCD) into V7700 sets eight channels active and causes the output data value to be read from pointer-designated V-memory as a BCD number.

Alternatively, loading a constant of 0088 (BCD) into V7700 sets eight channels active and causes the output data value to be read from pointer-designated V-memory as a binary number.

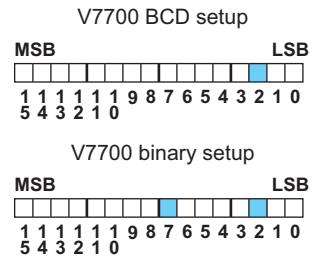

Storage Pointer Setup

System memory location V7702 is used as a pointer. It points to a user memory location where the analog output data is stored by the user program, pending distribution to the output module. An octal number is loaded to the pointer memory to identify the beginning of a block of user memory where output values are stored.

For example, loading O2100 into V7702 causes the CPU to look for Ch 1's output data value in V2100 – 2101, Ch 2's data value in V2102 – 2103, Ch 3's data value in V2104 – 2105, Ch 4's data value in V2106 – 2107, Ch 5's data value in V2110 – 2111, Ch 6's data value in V2112 – 2113, Ch 7's data value in V2114 – 2115, and Ch 8's data value in V2116 – 2117.

You will find an example program that loads appropriate values to V7700 and V7702 on page 8-9.

DL06 Data Formatting

Special V-memory locations are assigned to the four option slots of the DL06 PLC. The table below shows these V-memory locations which can be used to setup the F0-08DAH-1.

Analog Output Module DL06 Special V-memory Locations				
Slot No.	1	2	3	4
Data Type and Number of Channels	V700	V710	V720	V730
Output Pointer	V702	V712	V722	V732

Data Type and Number of Active Channels Setup

System memory locations V700, 710, 720, and 730 are used to set the data format either to BCD or binary and to set the number of channels that will be active.

For example, loading a constant of 0008 (BCD) into V700 sets eight channels active and causes the output data values to be read from pointer-designated V-memory as a BCD number.

Alternatively, loading a constant of 0088 (BCD) into V700 sets eight channels active and causes the output data value to be read from pointer-designated V-memory as a binary number.

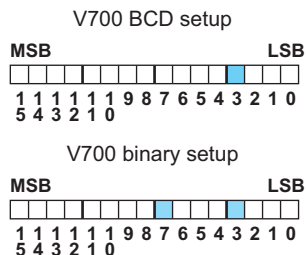

Storage Pointer Setup

System memory locations V702, 712, 722, and 732 are used as pointers. They point to user memory locations where the analog output data is stored by the user program, pending distribution to the output module. An octal number is loaded to the pointer memory to identify the beginning of a block of user memory where output values are stored.

For example, loading O2100 into V702 causes the CPU to look for Ch 1's output data value in V2100 – 2101, Ch 2's data value in V2102 – 2103, Ch 3's data value in V2104 – 2105, Ch 4's data value in V2106 – 2107, Ch 5's data value in V2110 – 2111, Ch 6's data value in V2112 – 2113, Ch 7's data value in V2114 – 2115, and Ch 8's data value in V2116 – 2117.

You will find an example program that loads appropriate values to V700 and V702 on page 8-10.

Using the Pointer in Your Control Program

DL05 Pointer Method Using Conventional Ladder Logic



NOTE: The proper use of the DL05 pointer requires that the V-memory address be written to the special memory location on the first scan only. Use the SP0 bit as a permissive contact when using the code shown below.

The example program below shows how to setup the special V-memory locations. This rung can be placed anywhere in the ladder program or in the initial stage if you are using stage programming instructions.

This is all that is required to read the analog output data from V-memory locations. In the example, V2100 is used, but you can use any user V-memory location.

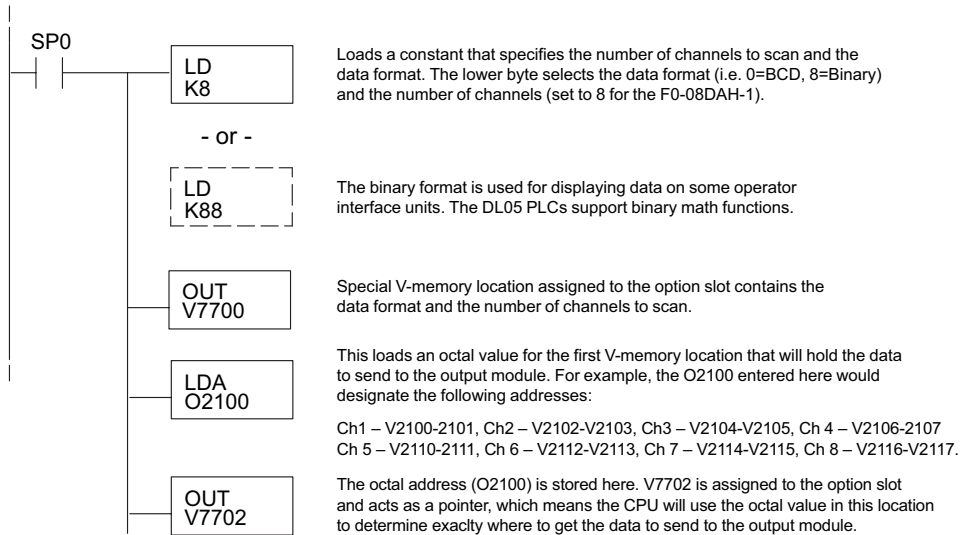

DL05 Pointer Method Using the IBox Instruction Available in DirectSOFT6

The following logic accomplishes the same thing as the previous ladder example, but it uses the IBox instruction ANLGOUT.

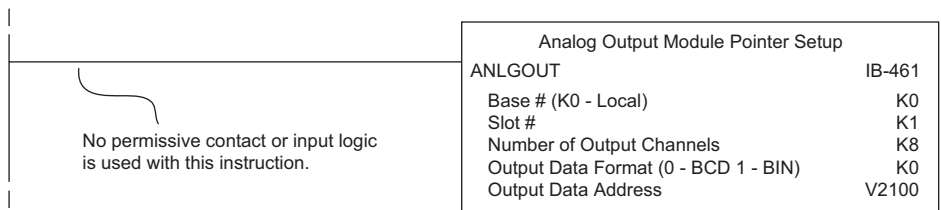

DL06 Pointer Method Using Conventional Ladder Logic



NOTE: The proper use of the DL06 pointer requires that the V-memory address be written to the special memory location on the first scan only. Use the SP0 bit as a permissive contact when using the code shown below.

Use the special V-memory table below as a guide to setup the storage pointer in the following example for the DL06. Slot 1 is the left most option slot.

Analog Output Module DL06 Special V-memory Locations				
Slot No.	1	2	3	4
No. of Channels	V700	V710	V720	V730
Output Pointer	V702	V712	V722	V732

The F0-08DAH-1 can be installed in any available DL06 option slot. Using the example program from the previous page, but changing the V-memory addresses, the ladder diagram below shows how to setup these locations with the module installed in slot 1 of the DL06. Use the above table to determine the pointer values if locating the module in any of the other slot locations. Place this rung anywhere in the ladder program or in the initial stage if you are using stage programming instructions.

This logic is all that is required to write the analog output data from V-memory locations. In the example, V2100 is used, but you can use any user V-memory location.

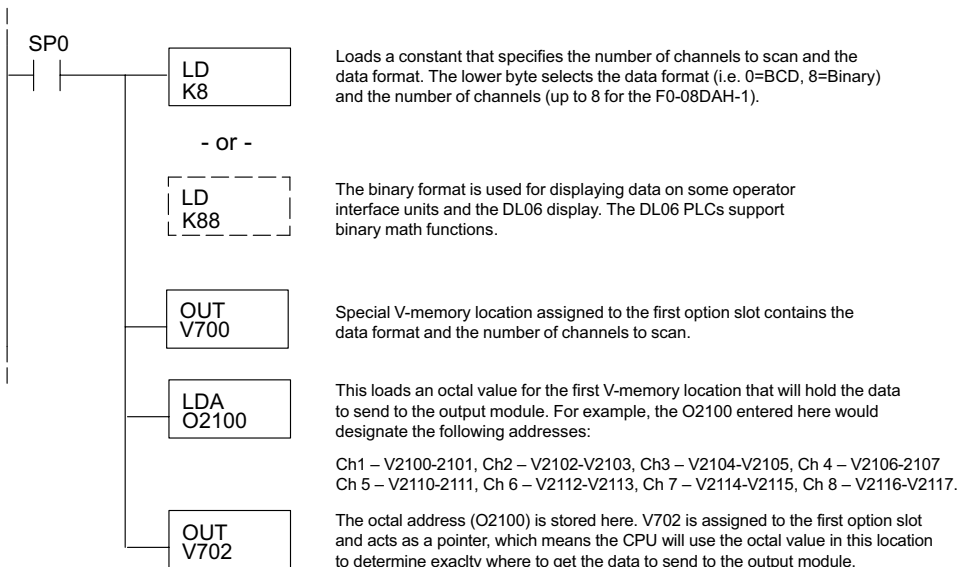

DL06 Pointer Method Using the IBox Instruction Available in DirectSOFT5

The following logic accomplishes the same thing as the previous ladder example, but it uses the IBox instruction ANLGOUT.

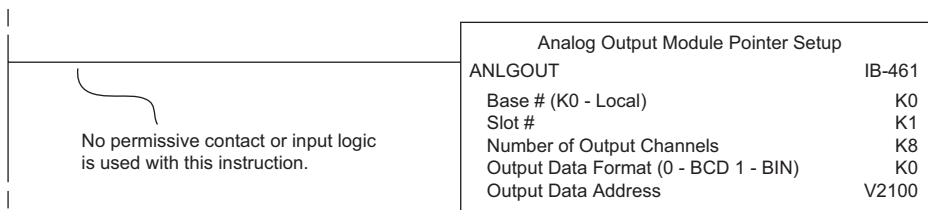

Output Scale Conversion

Calculating the Digital Output Value

Your program has to calculate the digital value to send to the analog output module. Most applications use measurements in engineering units, so it is usually necessary to convert from engineering units to a suitable output value. The conversion to an output value can be accomplished by using the conversion formula shown.

You will need to substitute the engineering units for your scale into the formula to the right.

For example, if you want to output pressure (PSI) between 0.0 and 100.0, you may multiply the pressure value by 10 to store in a V-memory location and eliminate the decimal point. Notice how the calculations differ when you use the multiplier.

The following example demonstrates how to output 49.4 PSI.

$$A = \frac{U - L}{H - L} \cdot 65535$$

U = Engineering units to output

H = High limit of the engineering unit range

L = Low limit of the engineering unit range

A = Analog value (0 – 65535)

Example without multiplier	Example with multiplier
$A = \frac{U - L}{H - L} \cdot 65535$	$A = \frac{U - L}{H - L} \cdot 65535$
$A = \frac{49 - 0}{100 - 0} \cdot 65535$	$A = \frac{494 - 0}{1000 - 0} \cdot 65535$
A = 32112	A = 32374

The Conversion Program in Standard Ladder Logic

The following example shows how you would write the program to perform the engineering unit conversion. This example assumes you have BCD data loaded into the appropriate V-memory locations using instructions that apply for the model of CPU you are using.

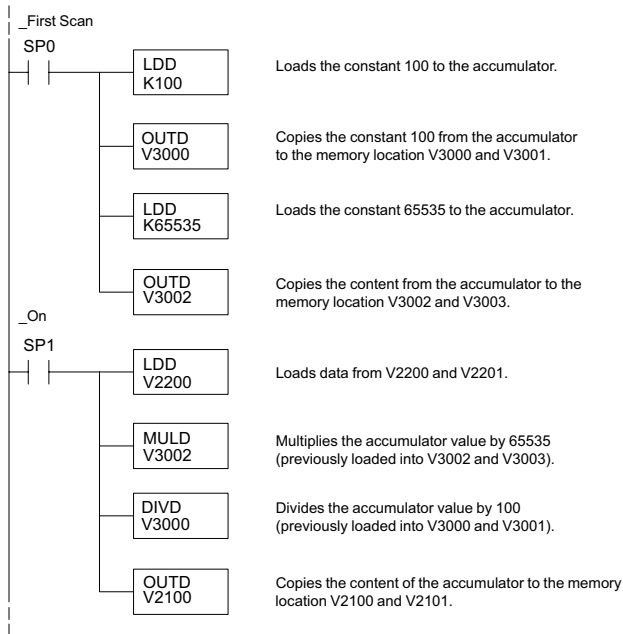

Analog and Digital Value Conversions

Sometimes it is useful to convert between the signal levels and the digital values. This is especially helpful during machine startup or troubleshooting. The following table provides formulas to make this conversion easier.

The formulas in the table show the relationship between A, the analog value, and D, the digital value.

Range	If you know the digital value	If you know the analog signal level
4 to 20mA	$A = \left(\frac{16}{65535} \cdot D \right) + 4\text{mA}$	$D = \frac{65535}{16} \cdot (A - 4\text{mA})$

For example, if you need a 10mA signal to achieve the desired result, you can use the formula to determine the digital value that should be used.

$$D = \frac{65535}{16} \cdot (A - 4\text{mA})$$

$$D = \frac{65535}{16} \cdot (10\text{mA} - 4\text{mA})$$

$$D = 24576$$

Module Resolution

Analog Data Bits

Two 16-bit words are reserved for the analog data whether you are using BCD or binary data formatting. The 16 bits in the low word represent the analog data in binary format.

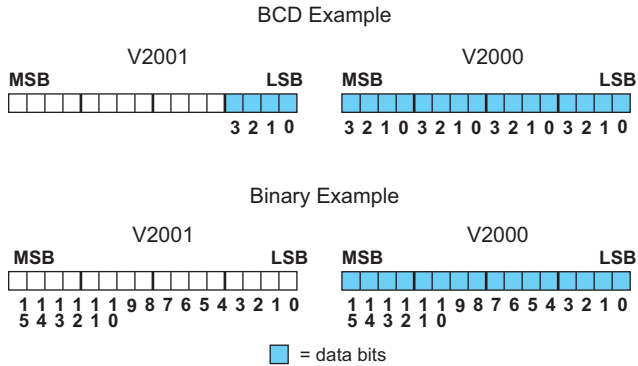

Resolution Details

Since the module has 16-bit resolution, the analog signal is converted into 65,536 counts ranging from 0 - 65,535 (2^{16}). A 4mA signal would be 0 and a 20mA signal would be 65535. This is equivalent to a binary value of 0000 0000 0000 0000 to 1111 1111 1111 1111, or 000 to FFFF hexadecimal.

Each count can also be expressed in terms of the signal level by using the following equation:

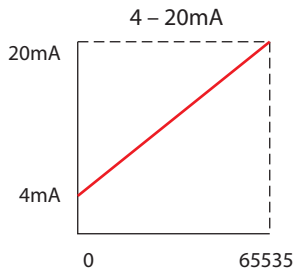

$$\text{Resolution} = \frac{H - L}{65535}$$

H = high limit of the signal range

L = low limit of the signal range

The following table shows the smallest detectable signal change that will result in one LSB change in the data value for each increment of the signal change.

mA Range	Signal Span (H - L)	Divide By	Smallest Detectable Change
4 to 20 mA	16mA	65535	0.244 μ A

F0-04DAH-2, 4-CHANNEL ANALOG VOLTAGE OUTPUT



In This Chapter...

Module Specifications	9-2
Connecting and Disconnecting the Field Wiring	9-4
Wiring Diagram	9-5
Module Operation	9-6
Special V-memory Locations	9-7
Using the Pointer in Your Control Program	9-9
Output Scale Conversion.....	9-11
Module Resolution.....	9-14

Module Specifications

The F0-04DAH-2 analog output module offers the following features:

- The DL05 and DL06 will update all four channels in one scan.
- The removable terminal block simplifies module replacement.
- Full 16-bit resolution.

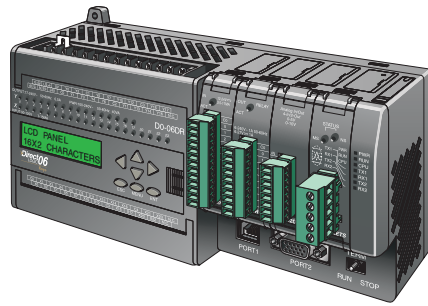

NOTE: The DL05 CPU's analog feature for this module requires **DirectSOFT32 Version 3.0c (or later)** and firmware version 5.20 (or later). The DL06 requires **DirectSOFT32 version V4.0, build 16 (or later)** and firmware version 2.30 (or later). See our website for more information: www.automationdirect.com.

The following tables provide the specifications for the F0-04DAH-2 Analog Output Module. Review these specifications to make sure the module meets your application requirements.

Output Specifications	
Outputs per module	4
Output Range	0–10 VDC
Resolution	16-bit, 152 μ V/bit
Output Type	Voltage sourcing/sinking at 5mA max.
PLC Data Format	16-bit, Unsigned Integer, 0–FFFF (binary) or 0–65535 (BCD)
Output value in program mode	0V (excluding PID, independent mode)
Output Impedance	0.5 Ohms typical
Load Impedance	>2000 Ohms
Maximum Capacitive Load	0.01 μ F maximum
Allowed load type	Grounded
Maximum Inaccuracy	0.2% of range (including temperature changes)
Maximum Full Scale Calibration Error (including offset error)	\pm 0.025% of range maximum
Maximum Offset Calibration Error	\pm 0.025% of range maximum
Accuracy vs. Temperature	\pm 50 ppm/ $^{\circ}$ C maximum full scale calibration change
Maximum Crosstalk	\pm 10 counts
Linearity Error (End to End)	\pm 16 count maximum (\pm 0.025% of full scale) Monotonic with no missing codes
Output Stability and Repeatability	\pm 10 counts after 10 min. warm-up typical
Output Ripple	0.05% of Full Scale
Output Settling Time	0.5 ms maximum, 5 μ s minimum (full scale change)
All Channel Update Rate	100 μ s
Maximum Continuous Overload	Outputs current limited to 40mA typical. A continuous short circuit will damage the output.
Type of Output Protection	24VDC Peak Output Voltage (capacitor transient voltage suppressor)
Output signal at power-up and power-down	0V
External 24VDC Power Required	24VDC \pm 10% @45mA
Base Power Required (5.0 V)	25mA

Each channel requires 2 words of V-memory irrespective of the format used.

General Specifications	
Operating Temperature	0 to 55 $^{\circ}$ C (32 to 131 $^{\circ}$ F)
Storage Temperature	-20 to 70 $^{\circ}$ C (-4 to 158 $^{\circ}$ F)
Humidity	5 to 95% (non-condensing)
Environmental air	No corrosive gases permitted (EN61131-2 pollution degree 1)
Vibration	MIL STD 810C 514.2
Shock	MIL STD 810C 516.2
Field to Logic side Isolation	1800VAC applied for 1 second (100% tested)
Insulation Resistance	>10M ohms @ 500VDC
Noise Immunity	NEMA ICS3-304; Impulse 1000V @ 1ms pulse; RFI, (145MHz, 440Mhz 5W @ 15cm); Worst case error during noise disturbance is 0.5% of full scale
Agency Approvals	UL508; UL60079-15 Zone 2
Module Location	Any slot in a DL05 or DL06 System
Field Wiring	Removable Terminal Block
Weight	49g (1.7 oz.)

Connecting and Disconnecting the Field Wiring



WARNING: Before removing the analog module or the terminal block on the face of the module, disconnect power to the PLC and all field devices. Failure to disconnect power can result in damage to the PLC and/or field devices.

Wiring Guidelines

Your company may have guidelines for wiring and cable installation. If so, you should check those before you begin the installation. Here are some general things to consider:

- Use the shortest wiring route whenever possible.
- Use shielded wiring and ground the shield at the transmitter source. *Do not* ground the shield at both the module and the source.
- Do not run the signal wiring next to large motors, high current switches, or transformers. This may cause noise problems.
- Route the wiring through an approved cable housing to minimize the risk of accidental damage. Check local and national codes to choose the correct method for your application.

The F0-04DAH-2 does not supply power to field devices. You will need to power transmitters separately from the PLC.

To remove the terminal block, disconnect power to the PLC and the field devices. Pull the terminal block firmly until the connector separates from the module.

You can remove the analog module from the PLC by folding out the retaining tabs at the top and bottom of the module. As the retaining tabs pivot upward and outward, the module's connector is lifted out of the PLC socket. Once the connector is free, you can lift the module out of its slot.

Terminal Block Specifications	
Number of Positions	13
Re-Order Number	D0-ACC-4
Pitch	0.2 inch (5.08 mm)
Wire Range	28-16 AWG Solid or Stranded Conductor; Wire strip length 5/16" (7-8 mm)
Screwdriver Size (Slotted)	0.4T x 2.5W mm (part number DN-SS1)
Screw Size	M2.5 size
Screw Torque	4.5 inch-pounds (0.52 N·m)

Wiring Diagram

Use the following diagram to connect the field wiring. If necessary, the F0-04DAH-2 terminal block can be removed to make removal of the module possible without disturbing field wiring.

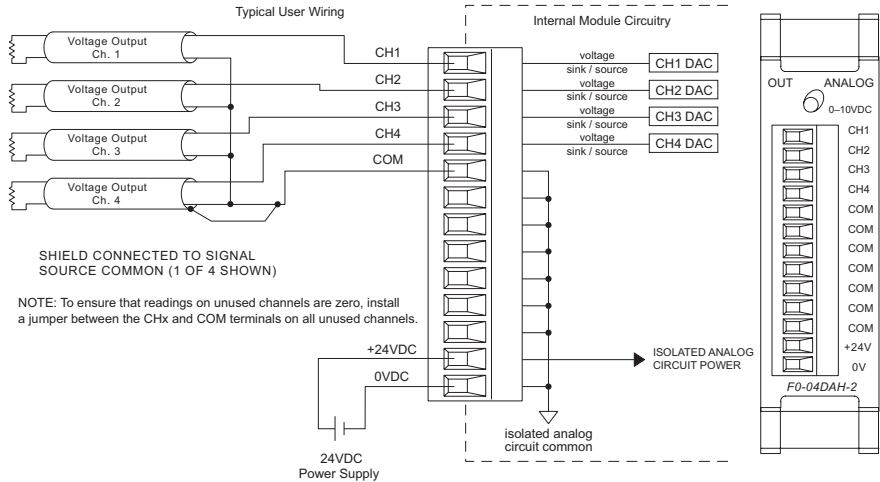

Module Operation

Channel Scanning Sequence

The DL05 and DL06 will read all four channels of output data during each scan. Each CPU supports special V-memory locations that are used to manage the data transfer. This is discussed in more detail beginning in the section on “Special V-memory Locations”.

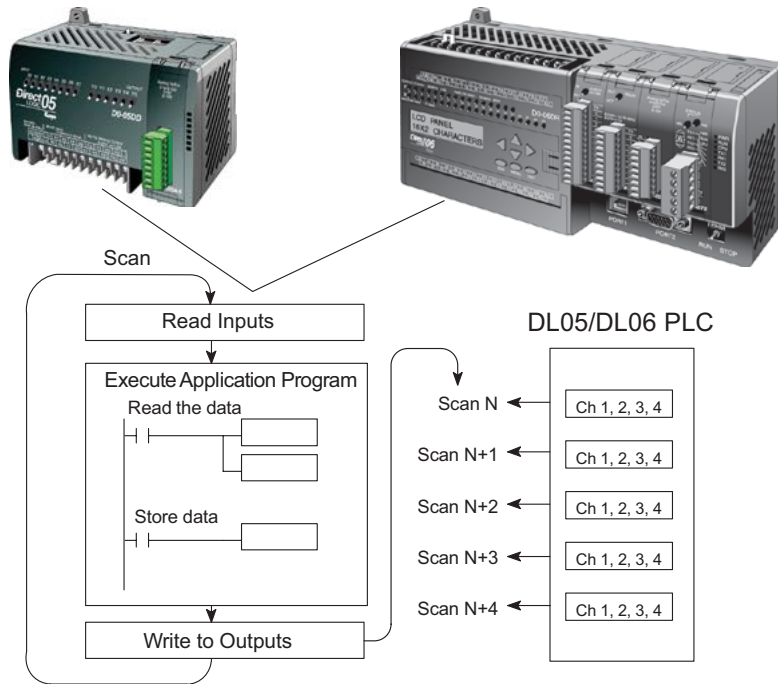

Special V-memory Locations

Formatting the Analog Module Data

The DL05 and DL06 PLCs have special V-memory locations assigned to their respective option slots. These V-memory locations allow you to:

- Specify the data format (binary or BCD)
- Specify the number of channels to scan (up to 4 channels for the F0-04DAH-2)
- Specify the V-memory locations where the user program will store the output data pending distribution to the output module

DL05 Data Formatting

The table below shows the special V-memory locations used by the DL05 PLC for the F0-04DAH-2.

Analog Output Module DL05 Special V-memory Locations	
Data Type and Number of Channels	V7700
Storage Pointer	V7702

Data Type and Number of Active Channels Setup

System memory location V7700 is used to set the data format either to BCD or binary and to set the number of channels that will be active.

For example, loading a constant of 0004 (BCD) into V7700 sets four channels active and causes the output data value to be read from pointer-designated V-memory as a BCD number.

Alternatively, loading a constant of 0084 (BCD) into V7700 sets four channels active and causes the output data value to be read from pointer-designated V-memory as a binary number.

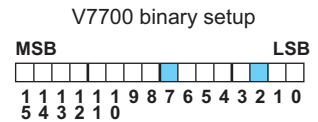
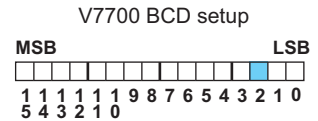

Storage Pointer Setup

System memory location V7702 is used as a pointer. It points to a user memory location where the analog output data is stored by the user program, pending distribution to the output module. An octal number is loaded to the pointer memory to identify the beginning of a block of user memory where output values are stored.

For example, loading O2100 into V7702 causes the CPU to look for Ch 1's output data value in V2100 – 2101, Ch 2's data value in V2102 – 2103, Ch 3's data value in V2104 – 2105, and Ch 4's data value in V2106 – 2107.

You will find an example program that loads appropriate values to V7700 and V7702 on page 9-9.

DL06 Data Formatting

Special V-memory locations are assigned to the four option slots of the DL06 PLC. The table below shows these V-memory locations which can be used to setup the F0-04DAH-2.

Analog Output Module DL06 Special V-memory Locations				
Slot No.	1	2	3	4
Data Type and Number of Channels	V700	V710	V720	V730
Output Pointer	V702	V712	V722	V732

Data Type and Number of Active Channels Setup

System memory locations V700, 710, 720, and 730 are used to set the data format either to BCD or binary and to set the number of channels that will be active.

For example, loading a constant of 0004 (BCD) into V700 sets four channels active and causes the output data value to be read from pointer-designated V-memory as a BCD number.

Alternatively, loading a constant of 0084 (BCD) into V700 sets four channels active and causes the output data value to be read from pointer-designated V-memory as a binary number.

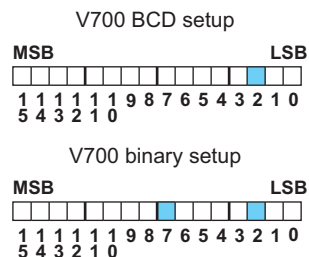

Storage Pointer Setup

System memory locations V702, 712, 722, and 732 are used as pointers. They point to user memory locations where the analog output data is stored by the user program, pending distribution to the output module. An octal number is loaded to the pointer memory to identify the beginning of a block of user memory where output values are stored.

For example, loading O2100 into V702 causes the CPU to look for Ch 1's output data value in V2100 – 2101, Ch 2's data value in V2102 – 2103, Ch 3's data value in V2104 – 2105, and Ch 4's data value in V2106 – 2107.

You will find an example program that loads appropriate values to V7700 and V7702 on page 9-10.

Using the Pointer in Your Control Program

DL05 Pointer Method Using Conventional Ladder Logic



NOTE: The proper use of the DL05 pointer requires that the V-memory address be written to the special memory location on the first scan only. Use the SP0 bit as a permissive contact when using the code shown below.

The example program below shows how to setup the special V-memory locations. This rung can be placed anywhere in the ladder program or in the initial stage if you are using stage programming instructions.

This is all that is required to read the analog output data from V-memory locations. In the example, V2100 is used, but you can use any user V-memory location.

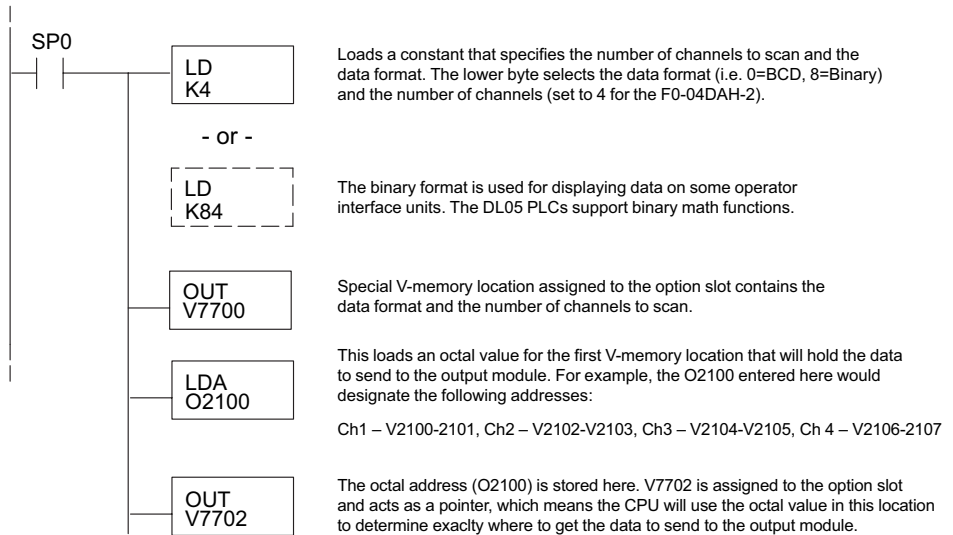

DL05 Pointer Method Using the IBox Instruction Available in DirectSOFT6

The following logic accomplishes the same thing as the previous ladder example, but it uses the IBox instruction ANLGOUT.

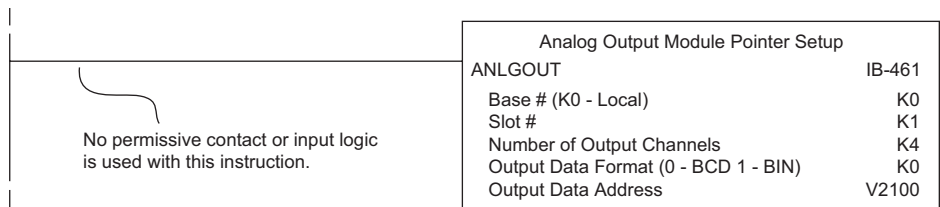

DL06 Pointer Method Using Conventional Ladder Logic



NOTE: The proper use of the DL06 pointer requires that the V-memory address be written to the special memory location on the first scan only. Use the SPO bit as a permissive contact when using the code shown below.

Use the special V-memory table below as a guide to setup the storage pointer in the following example for the DL06. Slot 1 is the left most option slot.

Analog Output Module DL06 Special V-memory Locations				
Slot No.	1	2	3	4
No. of Channels	V700	V710	V720	V730
Output Pointer	V702	V712	V722	V732

The F0-04DAH-2 can be installed in any available DL06 option slot. The ladder diagram below shows how to setup these locations with the module installed in slot 1 of the DL06. Use the above table to determine the pointer values if locating the module in any of the other slot locations. Place this rung anywhere in the ladder program or in the initial stage if you are using stage programming instructions.

This logic is all that is required to write the analog output data from V-memory locations. In the example, V2100 is used, but you can use any user V-memory location.

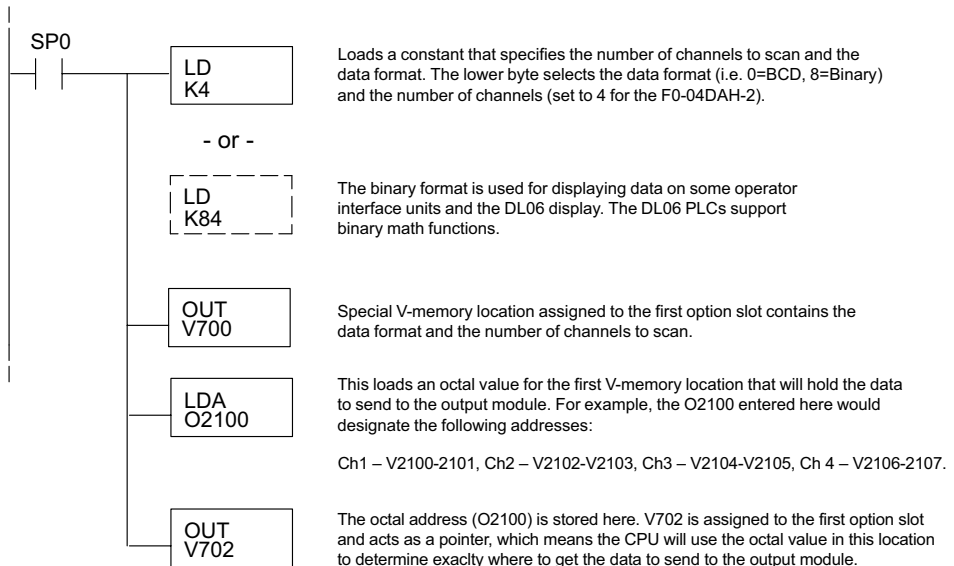

DL06 Pointer Method Using the IBox Instruction Available in DirectSOFT6

The following logic accomplishes the same thing as the previous ladder example, but it uses the IBox instruction ANLGOUT.

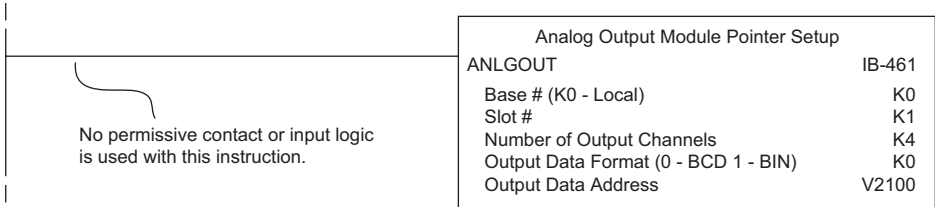

Output Scale Conversion

Calculating the Digital Output Value

Your program has to calculate the digital value to send to the analog output module. Most applications use measurements in engineering units, so it is usually necessary to convert from engineering units to a suitable output value. The conversion to an output value can be accomplished by using the conversion formula shown.

You will need to substitute the engineering units for your scale into the formula to the right.

For example, if you want to output pressure (PSI) between 0.0 and 100.0, you may multiply the pressure value by 10 to store in a V-memory location and eliminate the decimal point. Notice how the calculations differ when you use the multiplier.

The following example demonstrates how to output 49.4 PSI.

$$A = \frac{U - L}{H - L} \cdot 65535$$

U = Engineering units to output

H = High limit of the engineering unit range

L = Low limit of the engineering unit range

A = Analog value (0 – 65535)

Example without multiplier	Example with multiplier
$A = \frac{U - L}{H - L} \cdot 65535$	$A = \frac{U - L}{H - L} \cdot 65535$
$A = \frac{49 - 0}{100 - 0} \cdot 65535$	$A = \frac{494 - 0}{1000 - 0} \cdot 65535$
A = 32112	A = 32374

The Conversion Program in Standard Ladder Logic

The following example shows how you would write the program to perform the engineering unit conversion. This example assumes you have BCD data loaded into the appropriate V-memory locations using instructions that apply for the model of CPU you are using.

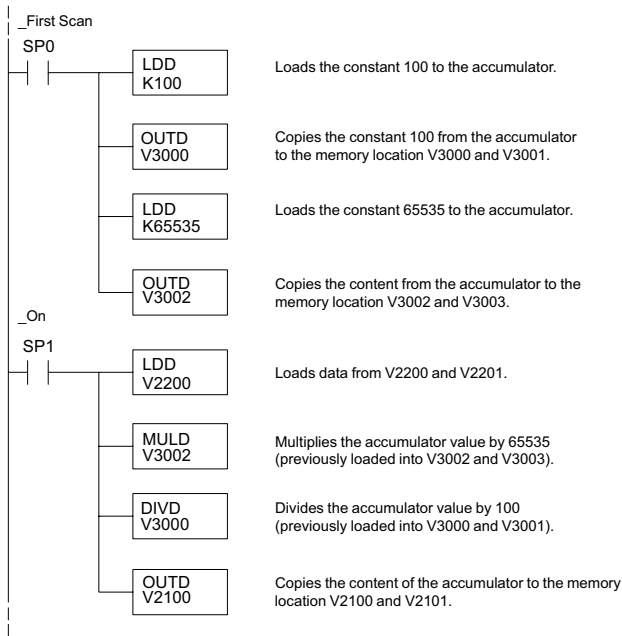

Analog and Digital Value Conversions

Sometimes it is useful to convert between the signal levels and the digital values. This is especially helpful during machine startup or troubleshooting. The following table provides formulas to make this conversion easier.

The formulas in the table show the relationship between A, the analog value, and D, the digital value.

Range	If you know the digital value	If you know the analog signal level
0 to 10VDC	$A = \frac{10}{65535} \cdot D$	$D = \frac{65535}{10} \cdot A$

For example, if you need a 6VDC signal to achieve the desired result, you can use the formula to determine the digital value that should be used.

$$D = \frac{65535}{10} \cdot A$$

$$D = \frac{65535}{10} \cdot 6V$$

$$D = 39321$$

Module Resolution

Analog Data Bits

Two 16-bit words are reserved for the analog data whether you are using BCD or binary data formatting. The 16 bits in the low word represent the analog data in binary format.

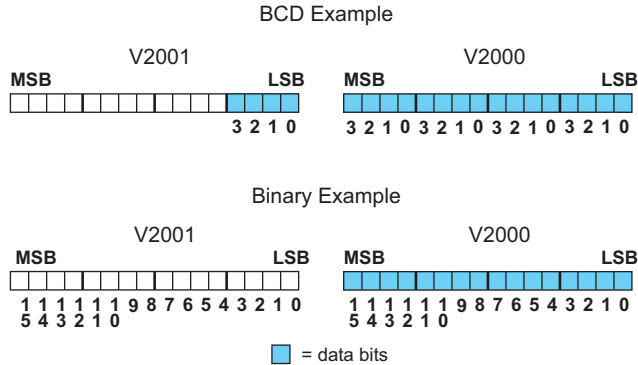

Resolution Details

Since the module has 16-bit resolution, the analog signal is converted into 65536 counts ranging from 0–65535 (2^{16}). A 0VDC signal would be 0 and a 10VDC signal would be 65535. This is equivalent to a binary value of 0000 0000 0000 0000 to 1111 1111 1111 1111, or 000 to FFFF hexadecimal.

Each count can also be expressed in terms of the signal level by using the following equation:

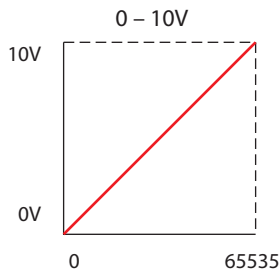

$$\text{Resolution} = \frac{H - L}{65535}$$

H = high limit of the signal range

L = low limit of the signal range

VDC Range	Signal Span (H – L)	Divide By	Smallest Detectable Change
0 to 10 VDC	10VDC	65535	153µV

F0-08DAH-2, 8-CHANNEL ANALOG VOLTAGE OUTPUT



CHAPTER 10

In This Chapter...

Module Specifications	10-2
Connecting and Disconnecting the Field Wiring	10-4
Wiring Diagram	10-5
Module Operation	10-6
Special V-memory Locations	10-7
Using the Pointer in Your Control Program	10-9
Output Scale Conversion.....	10-11
Module Resolution.....	10-14

Module Specifications

The F0-08DAH-2 analog output module offers the following features:

- The DL05 and DL06 will update all eight channels in one scan.
- The removable terminal block simplifies module replacement.
- Full 16-bit resolution.

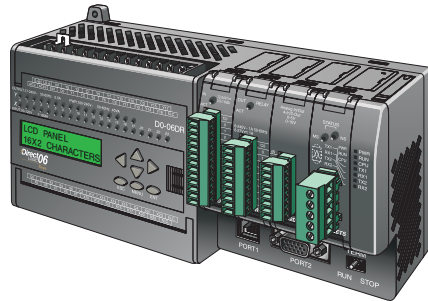

NOTE: The DL05 CPU's analog feature for this module requires **DirectSOFT32** Version 3.0c (or later) and firmware version 5.20 (or later). The DL06 requires **DirectSOFT32** version V4.0, build 16 (or later) and firmware version 2.30 (or later). See our website for more information: www.automationdirect.com.

Chapter 10: F0-08DAH-2, 8-Channel Analog Voltage Output

The following tables provide the specifications for the F0-08DAH –2 Analog Output Module. Review these specifications to make sure the module meets your application requirements.

Output Specifications	
Outputs per module	8
Output Range	0–10 VDC
Resolution	16-bit, 152 μ V/bit
Output Type	Voltage sourcing/sinking at 5mA max.
PLC Data Format	16-bit, Unsigned Integer, 0–FFFF (binary) or 0–65535 (BCD)*
Output value in program mode	0V (excluding PID, independent mode)
Output Impedance	0.5 Ohms typical
Load Impedance	>2000 Ohms
Maximum Capacitive Load	0.01 μ F maximum
Allowed load type	Grounded
Maximum Inaccuracy	0.27% of range (including temperature changes)
Maximum Full Scale Calibration Error (including offset error)	\pm 0.025% of range maximum
Maximum Offset Calibration Error	\pm 0.025% of range maximum
Accuracy vs. Temperature	\pm 50 ppm/ $^{\circ}$ C maximum full scale calibration change
Maximum Crosstalk at DC, 50 Hz and 60 Hz.	10 counts
Linearity Error (End to End)	\pm 16 count maximum (\pm 0.025% of full scale) Monotonic with no missing codes
Output Stability and Repeatability	\pm 10 counts after 10 min. warm-up typical
Output Ripple	0.05% of Full Scale
Output Settling Time	0.5 ms maximum, 5 μ s minimum (full scale change)
All Channel Update Rate	100 μ s
Maximum Continuous Overload	Outputs current limited to 40mA typical. A continuous short circuit will damage the output.
Type of Output Protection	24VDC Peak Output Voltage (capacitor transient voltage suppressor)
Output signal at power-up and power-down	0V
External 24VDC Power Required	24VDC \pm 10% @ 75mA
Base Power Required (5.0 V)	25mA

* Each channel requires 2 words of V-memory irrespective of the format used.

General Specifications	
Operating Temperature	0 to 55 $^{\circ}$ C (32 to 131 $^{\circ}$ F)
Storage Temperature	-20 to 70 $^{\circ}$ C (-4 to 158 $^{\circ}$ F)
Humidity	5 to 95% (non-condensing)
Environmental air	No corrosive gases permitted (EN61131-2 pollution degree 1)
Vibration	MIL STD 810C 514.2
Shock	MIL STD 810C 516.2
Field to Logic side Isolation	1800VAC applied for 1 second (100% tested)
Insulation Resistance	>10M ohms @ 500VDC
Noise Immunity	NEMA ICS3-304; Impulse 1000V @ 1ms pulse; RFI, (145MHz, 440MHz 5W @ 15cm); Worst case error during noise disturbance is 0.5% of full scale
Agency Approvals	UL508; UL60079-15 Zone 2
Module Location	Any slot in a DL05 or DL06 System
Field Wiring	Removable Terminal Block
Weight	49g (1.7 oz.)

Connecting and Disconnecting the Field Wiring



WARNING: Before removing the analog module or the terminal block on the face of the module, disconnect power to the PLC and all field devices. Failure to disconnect power can result in damage to the PLC and/or field devices.

Wiring Guidelines

Your company may have guidelines for wiring and cable installation. If so, you should check those before you begin the installation. Here are some general things to consider:

- Use the shortest wiring route whenever possible.
- Use shielded wiring and ground the shield at the transmitter source. *Do not* ground the shield at both the module and the source.
- Do not run the signal wiring next to large motors, high current switches, or transformers. This may cause noise problems.
- Route the wiring through an approved cable housing to minimize the risk of accidental damage. Check local and national codes to choose the correct method for your application.

The F0-08DAH-2 does not supply power to field devices. You will need to power transmitters separately from the PLC.

To remove the terminal block, disconnect power to the PLC and the field devices. Pull the terminal block firmly until the connector separates from the module.

You can remove the analog module from the PLC by folding out the retaining tabs at the top and bottom of the module. As the retaining tabs pivot upward and outward, the module's connector is lifted out of the PLC socket. Once the connector is free, you can lift the module out of its slot.

Terminal Block Specifications	
Number of Positions	13
Re-Order Number	D0-ACC-4
Pitch	0.2 inch (5.08 mm)
Wire Range	28-16 AWG Solid or Stranded Conductor; Wire strip length 5/16" (7-8 mm)
Screwdriver Size (Slotted)	0.4T x 2.5W mm (part number DN-SS1)
Screw Size	M2.5 size
Screw Torque	4.5 inch-pounds (0.52 N-m)

Wiring Diagram

Use the following diagram to connect the field wiring. If necessary, the F0-08DAH-2 terminal block can be removed to make removal of the module possible without disturbing field wiring.

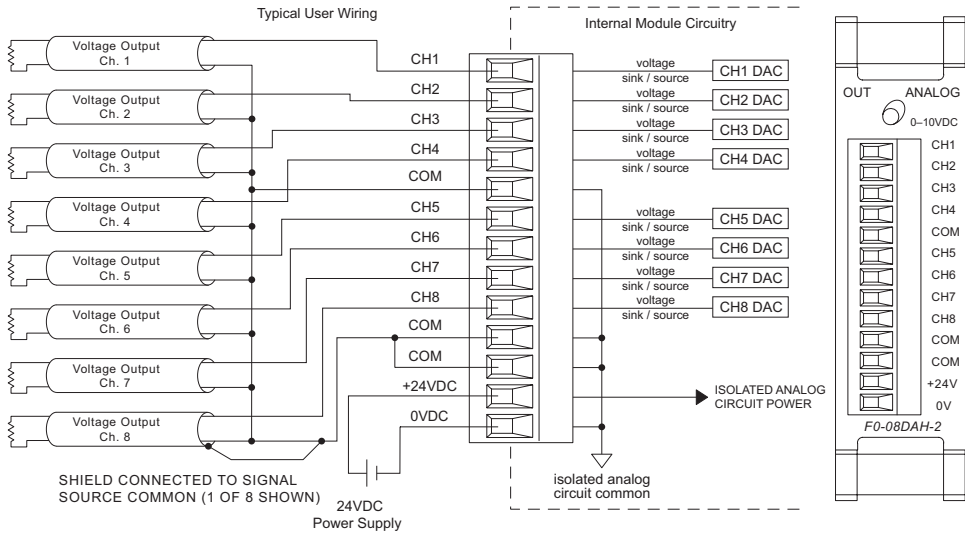

NOTE: To ensure that readings on unused channels are zero, install a jumper between the CHx and COM terminals on all unused channels.

Module Operation

Channel Scanning Sequence

The DL05 and DL06 will read all eight channels of output data during each scan. Each CPU supports special V-memory locations that are used to manage the data transfer. This is discussed in more detail beginning in the section on “Special V-memory Locations”.

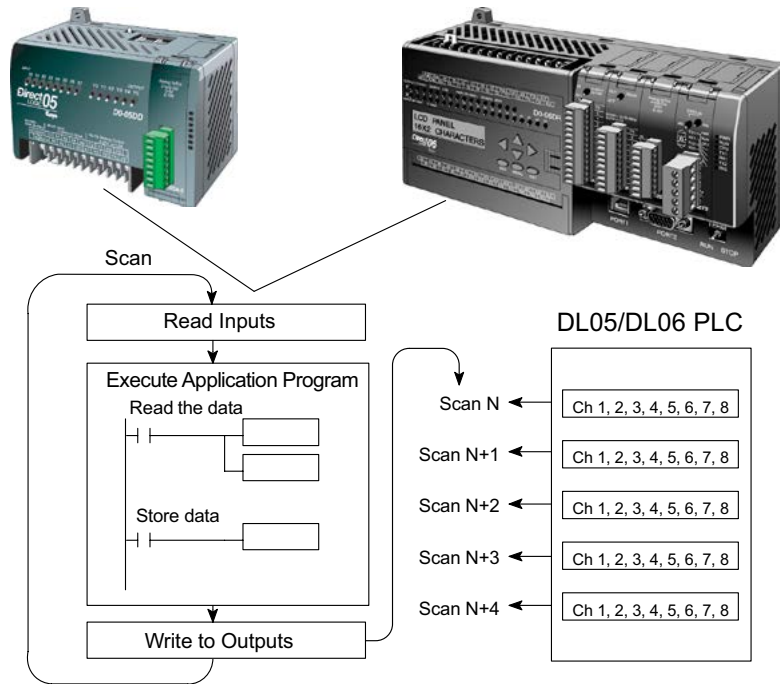

Special V-memory Locations

Formatting the Analog Module Data

The DL05 and DL06 PLCs have special V-memory locations assigned to their respective option slots. These V-memory locations allow you to:

- Specify the data format (binary or BCD)
- Specify the number of channels to scan (up to 8 channels for the F0-08DAH-2)
- Specify the V-memory locations where the user program will store the output data pending distribution to the output module

DL05 Data Formatting

The table below shows the special V-memory locations used by the DL05 PLC for the F0-08DAH-2.

Analog Output Module DL05 Special V-memory Locations	
Data Type and Number of Channels	V7700
Storage Pointer	V7702

Data Type and Number of Active Channels Setup

System memory location V7700 is used to set the data format either to BCD or binary and to set the number of channels that will be active.

For example, loading a constant of 0008 (BCD) into V7700 sets eight channels active and causes the output data value to be read from pointer-designated V-memory as a BCD number.

Alternatively, loading a constant of 0088 (BCD) into V7700 sets eight channels active and causes the output data value to be read from pointer-designated V-memory as a binary number.

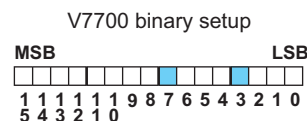
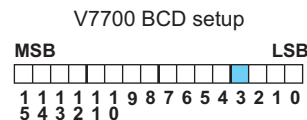

Storage Pointer Setup

System memory location V7702 is used as a pointer. It points to a user memory location where the analog output data is stored by the user program, pending distribution to the output module. An octal number is loaded to the pointer memory to identify the beginning of a block of user memory where output values are stored.

For example, loading O2100 into V7702 causes the CPU to look for Ch 1's output data value in V2100 – 2101, Ch 2's data value in V2102 – 2103, Ch 3's data value in V2104 – 2105, Ch 4's data value in V2106 – 2107, Ch 5's data value in V2110 – 2111, Ch 6's data value in V2112 – 2113, Ch 7's data value in V2114 – 2115, and Ch 8's data value in V2116 – 2117.

You will find an example program that loads appropriate values to V7700 and V7702 on page 10-9.

DL06 Data Formatting

Special V-memory locations are assigned to the four option slots of the DL06 PLC. The table below shows these V-memory locations which can be used to setup the F0-08DAH-2.

Analog Output Module DL06 Special V-memory Locations				
Slot No.	1	2	3	4
Data Type and Number of Channels	V700	V710	V720	V730
Output Pointer	V702	V712	V722	V732

Data Type and Number of Active Channels Setup

System memory locations V700, 710, 720, and 730 are used to set the data format either to BCD or binary and to set the number of channels that will be active.

For example, loading a constant of 0008 (BCD) into V700 sets eight channels active and causes the output data value to be read from pointer-designated V-memory as a BCD number.

Alternatively, loading a constant of 0088 (BCD) into V700 sets eight channels active and causes the output data value to be read from pointer-designated V-memory as a binary number.

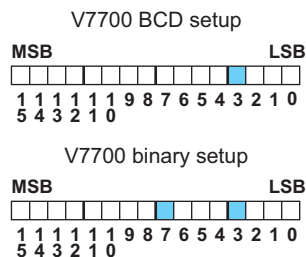

Storage Pointer Setup

V-memory locations 702, 712, 722 and 732 are special locations used as storage pointers. A V-memory address is loaded into this location as an octal number identifying the first user V-memory location for the analog output data. This V-memory location is user selectable. For example, loading O2100 causes the pointer to write Ch 1's data value to V2100 – 2101, Ch 2's data value to V2102 – 2103, Ch 3's data value to V2104 – 2105, Ch 4's data value to V2106 – 2107, Ch 5's data value to V2110 – 2111, Ch 6's data value to V2112 – 2113, Ch 7's data value to V2114 – 2115, and Ch 8's data value to V2116 – 2117.

You will find an example program that loads appropriate values to V700 and V702 beginning on page 10-10.

Using the Pointer in Your Control Program

DL05 Pointer Method Using Conventional Ladder Logic



NOTE: The proper use of the DL05 pointer requires that the V-memory address be written to the special memory location on the first scan only. Use the SPO bit as a permissive contact when using the code shown below.

The example program below shows how to setup the special V-memory locations. This rung can be placed anywhere in the ladder program or in the initial stage if you are using stage programming instructions.

This is all that is required to read the analog output data from V-memory locations. In the example, V2100 is used, but you can use any user V-memory location.

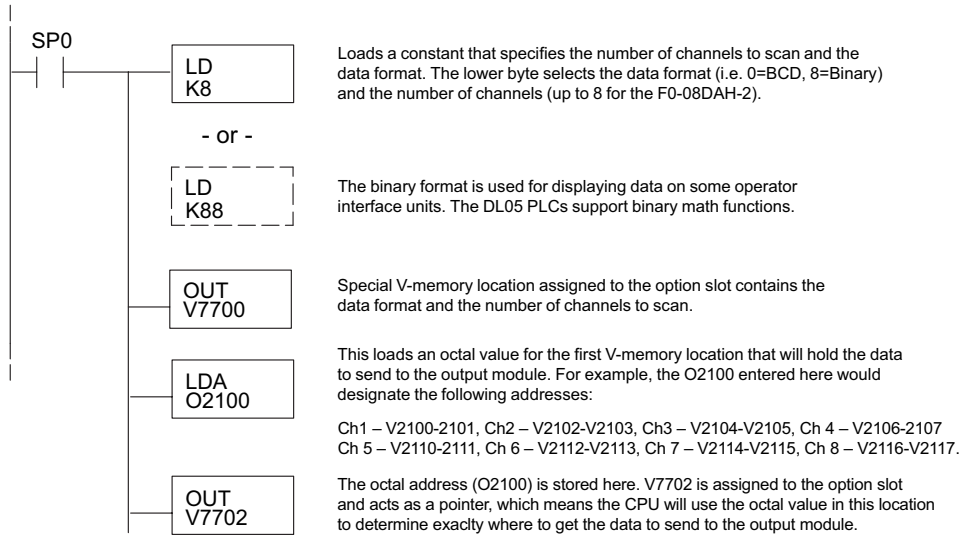

DL05 Pointer Method Using the IBox Instruction Available in DirectSOFT6

The following logic accomplishes the same thing as the previous ladder example, but it uses the IBox instruction ANLGOUT.

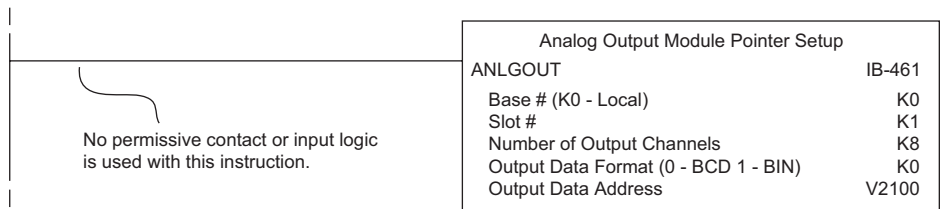

DL06 Pointer Method Using Conventional Ladder Logic



NOTE: The proper use of the DL06 pointer requires that the V-memory address be written to the special memory location on the first scan only. Use the SP0 bit as a permissive contact when using the code shown below.

Use the special V-memory table below as a guide to setup the storage pointer in the following example for the DL06. Slot 1 is the left most option slot.

Analog Output Module DL06 Special V-memory Locations				
Slot No.	1	2	3	4
No. of Channels	V700	V710	V720	V730
Output Pointer	V702	V712	V722	V732

The F0-08DAH-2 can be installed in any available DL06 option slot. The ladder diagram below shows how to setup these locations with the module installed in slot 1 of the DL06. Use the above table to determine the pointer values if locating the module in any of the other slot locations. Place this rung anywhere in the ladder program or in the initial stage if you are using stage programming instructions.

This logic is all that is required to write the analog output data from V-memory locations. In the example, V2100 is used, but you can use any user V-memory location.

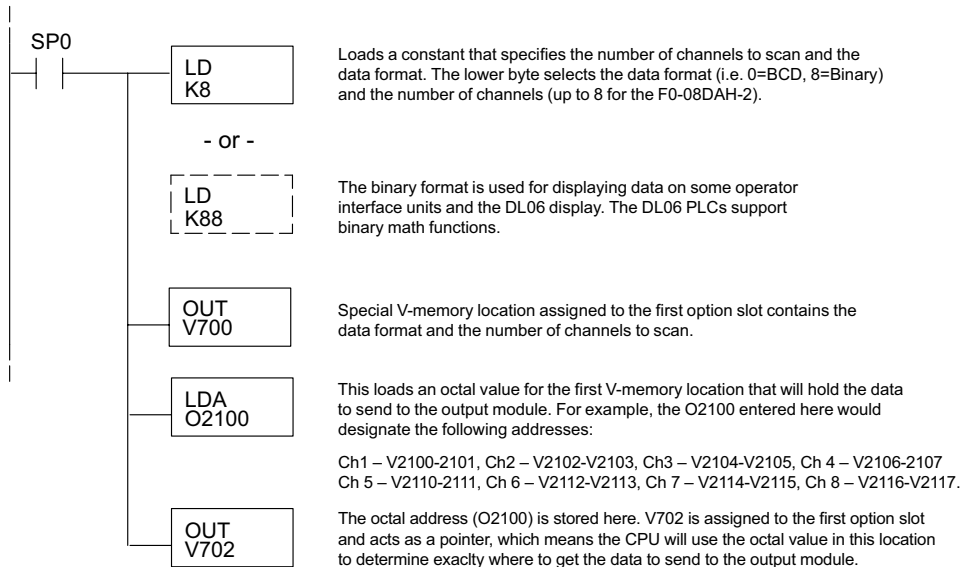

DL06 Pointer Method Using the IBox Instruction Available in DirectSOFT6

The following logic accomplishes the same thing as the previous ladder example, but it uses the IBox instruction ANLGOUT.

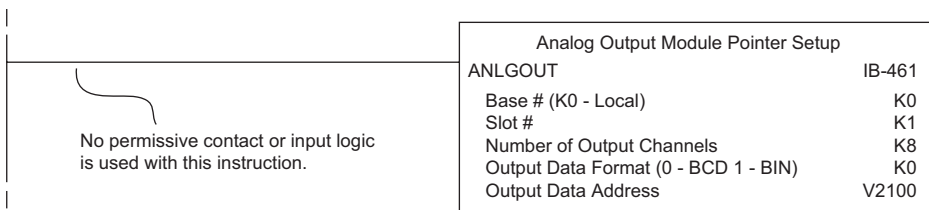

Output Scale Conversion

Calculating the Digital Output Value

Your program has to calculate the digital value to send to the analog output module. Most applications use measurements in engineering units, so it is usually necessary to convert from engineering units to a suitable output value. The conversion to an output value can be accomplished by using the conversion formula shown.

You will need to substitute the engineering units for your scale into the formula to the right.

For example, if you want to output pressure (PSI) between 0.0 and 100.0, you may multiply the pressure value by 10 to store in a V-memory location and eliminate the decimal point. Notice how the calculations differ when you use the multiplier.

The following example demonstrates how to output 49.4 PSI.

$$A = \frac{U - L}{H - L} \cdot 65535$$

U = Engineering units to output

H = High limit of the engineering unit range

L = Low limit of the engineering unit range

A = Analog value (0 – 65535)

Example without multiplier	Example with multiplier
$A = \frac{U - L}{H - L} \cdot 65535$	$A = \frac{U - L}{H - L} \cdot 65535$
$A = \frac{49 - 0}{100 - 0} \cdot 65535$	$A = \frac{494 - 0}{1000 - 0} \cdot 65535$
A = 32112	A = 32374

The Conversion Program in Standard Ladder Logic

The following example shows how you would write the program to perform the engineering unit conversion. This example assumes you have BCD data loaded into the appropriate V-memory locations using instructions that apply for the model of CPU you are using.

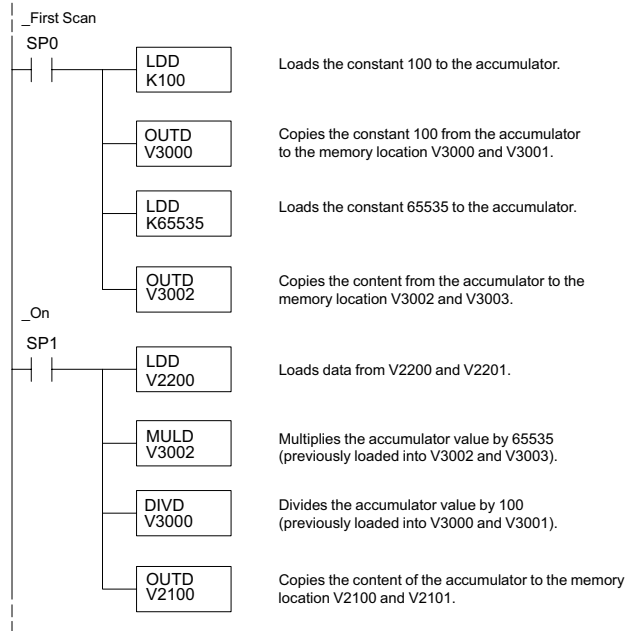

Analog and Digital Value Conversions

Sometimes it is useful to convert between the signal levels and the digital values. This is especially helpful during machine startup or troubleshooting. The following table provides formulas to make this conversion easier.

The formulas in the table show the relationship between A, the analog value, and D, the digital value.

Range	If you know the digital value	If you know the analog signal level
0 to 10VDC	$A = \frac{10}{65535} \cdot D$	$D = \frac{65535}{10} \cdot A$

For example, if you need a 6VDC signal to achieve the desired result, you can use the formula to determine the digital value that should be used.

$$D = \frac{65535}{10} \cdot A$$

$$D = \frac{65535}{10} \cdot 6V$$

$$D = 39321$$

Module Resolution

Analog Data Bits

Two 16-bit words are reserved for the analog data whether you are using BCD or binary data formatting. The 16 bits in the low word represent the analog data in binary format.

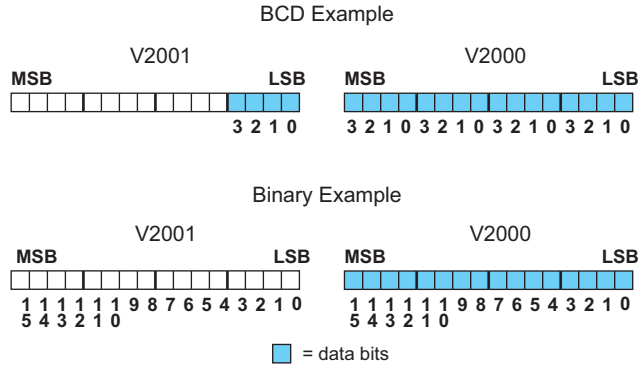

Resolution Details

Since the module has 16-bit resolution, the analog signal is converted into 65536 counts ranging from 0–65535 (2^{16}). A 0VDC signal would be 0 and a 10VDC signal would be 65535. This is equivalent to a binary value of 0000 0000 0000 0000 to 1111 1111 1111 1111, or 000 to FFFF hexadecimal.

Each count can also be expressed in terms of the signal level by using the following equation:

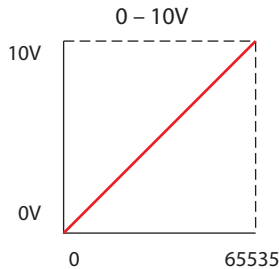

$$\text{Resolution} = \frac{H - L}{65535}$$

H = high limit of the signal range

L = low limit of the signal range

VDC Range	Signal Span (H – L)	Divide By	Smallest Detectable Change
0 to 10VDC	10VDC	65535	153µV

F0-4AD2DA-1, 4-CHANNEL IN/2-CH. OUT ANALOG CURRENT COMBINATION



In This Chapter...

Module Specifications	11-2
Setting the Module Jumper.....	11-4
Connecting and Disconnecting the Field Wiring	11-5
Wiring Diagram	11-6
Module Operation	11-7
Special V-memory Locations	11-8
Using the Pointer in Your Control Program	11-11
Scale Conversions	11-13
Special Relays.....	11-16
Module Resolution.....	11-18
Analog Input Ladder Logic Filter	11-19

Module Specifications

The F0-4AD2DA-1 Analog Combination module offers the following features:

- The analog input and output channels are updated in one scan.
- The removable terminal block makes it possible to remove the module without disconnecting the field wiring.
- Analog inputs can be used as process variables for the four (4) PID loops in the DL05 and the eight (8) PID loops in the DL06 CPUs.
- On-board active analog filtering and RISC-like microcontroller provide digital signal processing to maintain precise analog measurements in noisy environments.

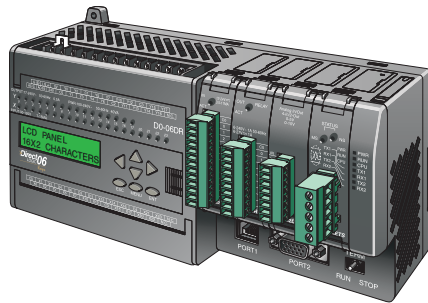
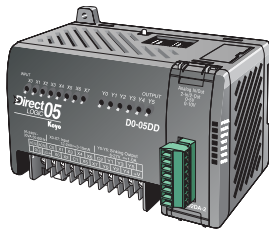
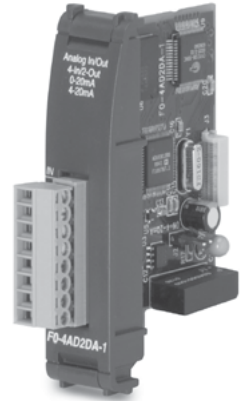

NOTE: The DL05 CPU's analog feature for this module requires **DirectSOFT32** Version 3.0c (or later) and firmware version 3.30 (or later). The DL06 requires **DirectSOFT32** version V4.0, build 16 (or later) and firmware version 1.00 (or later). See our website for more information: www.automationdirect.com.

The following tables provide the specifications for the F0-4AD2DA-1 Analog Combination Module. Review these specifications to make sure the module meets your application requirements.

Input Specifications	
Number of Channels	4, single ended (one common)
Input Range	0 to 20mA or 4 to 20mA (jumper selectable)
Resolution	12 bit (1 in 4096) for 0–20 mA, scaled for 4–20 mA
Step Response	25.0 ms (typ) to 95% of full step change
Crosstalk	-80dB, 1/2 count maximum*
Active Low-pass Filtering	-3dB at 40Hz (-12dB per octave)
Input Impedance	125 Ohm \pm 0.1%, 1/8 W current input
Absolute Maximum Ratings	-30mA to +30mA current input
Converter type	Successive approximation
Linearity Error (End to End)	\pm 2 counts
Input Stability	\pm 1 count*
Full Scale Calibration Error (Offset error not included)	\pm 10 counts maximum @ 20mA current input*
Offset Calibration Error	\pm 5 counts maximum @ 0mA current input*
Maximum Inaccuracy	\pm 0.4% @ 25°C (77°F) \pm 0.85% 0 to 60°C (32 to 140°F)
Accuracy vs Temperature	\pm 100ppm typical full scale calibration (Including maximum offset change)
Recommended Fuse (external)	0.032 A Series 217 fast-acting, current inputs

*One count in the specification table is equal to one least significant bit of the analog data value (1 in 4096).

Output Specifications	
Number of Channels	2, single ended (one common)
Output Range	4 to 20mA or 0 to 20mA (jumper selectable)
Output Type	Current sourcing
Resolution	12 bit (1 in 4096) for 0 to 20mA, scaled for 4 to 20mA
Maximum Loop Voltage	30VDC
Load (ohms)/Loop Power Supply	0–300/18–30 V
Linearity Error (end to end)	\pm 2 counts (\pm 0.050% of full scale) maximum*
Conversion Settling Time	400 μ S max. full scale change
Full Scale Calibration Error Note: Error depends on the load from source terminal to ground.	\pm 26 counts max. @ 300 Ω load \pm 18 counts max. @ 250 Ω load \pm 12 counts max. @ 125 Ω load
Offset Calibration Error	\pm 10 counts max. @ 300 Ω load \pm 8 counts max @ 250 Ω load \pm 6 counts max. @ 125 Ω load
Max. Full Scale Inaccuracy (% of full scale) all errors included	300 Ω load 0.4% @ 60°C 250 Ω load 0.3% @ 60°C 125 Ω load 0.2% @ 60°C

* One count in the specification tables is equal to one least significant bit of the analog data value (1 in 4096).

General Specifications	
PLC Update Rate	4 input channels per scan, 2 output channels per scan
16-bit Data Word	12 binary data bits
Operating Temperature	0 to 60°C (32 to 140°F)
Storage Temperature	-20 to 70°C (-4 to 158°F)
Relative Humidity	5 to 95% (non-condensing)
Environmental Air	No corrosive gases permitted
Vibration	MIL STD 810C 514.2
Shock	MIL STD 810C 516.2
Noise Immunity	NEMA ICS3-304
Power Budget Requirement	100mA @ 5VDC (supplied by base)
Connector	Phoenix Mecano, Inc., Part No. AK1550/8-3.5 - green
Connector Wire Size	28–16 AWG
Connector Screw Torque	3.5 inch-pounds (0.4 N-m)
Connector Screwdriver Size	DN-SS1 (recommended)

Setting the Module Jumper

The position of the J2 jumper determines the input and output signal level. You can choose between 0–20 mA and 4–20 mA signal levels. The module ships without the jumper connecting the pins (pins not jumpered). In this position, the input and output signal level is 4–20 mA. To select 0–20 mA signal level, install the jumper, connecting the pins.

The J2 jumper is shown in the 4–20 mA position (not installed). Install the jumper for the 0–20 mA position.

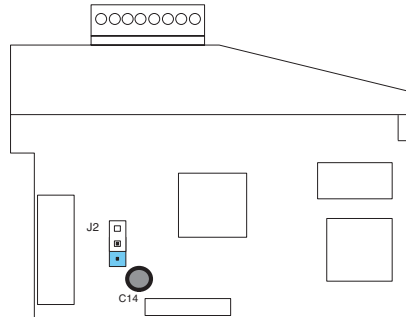

WARNING: Before removing the analog module or the terminal block on the face of the module, disconnect power to the PLC and all field devices. Failure to disconnect power can result in damage to the PLC and/or field devices.

Connecting and Disconnecting the Field Wiring

Wiring Guidelines

Your company may have guidelines for wiring and cable installation. If so, you should check those before you begin the installation. Here are some general things to consider:

- Use the shortest wiring route whenever possible.
- Use shielded wiring and ground the shield at the transmitter source. Do not ground the shield at both the module and the source.
- Do not run the signal wiring next to large motors, high current switches, or transformers. This may cause noise problems.
- Route the wiring through an approved cable housing to minimize the risk of accidental damage. Check local and national codes to choose the correct method for your application.

A separate transmitter power supply may be required, depending on the type of transmitter being used.

This module has a removable connector to make wiring and module removal easier. To remove the terminal block, disconnect power to the PLC and the field devices. Pull the terminal block firmly until the connector separates from the module.

The analog module can be removed from the PLC by folding out the retaining tabs at the top and bottom of the module. As the retaining tabs pivot upward and outward, the module's connector is lifted out of the PLC socket. Once the connector is free, you can lift the module out of its slot.

Wiring Diagram

Use the following diagram to connect the field wiring. If necessary, the terminal block can be removed to make removal of the module possible without disturbing field wiring.

Typical User Wiring

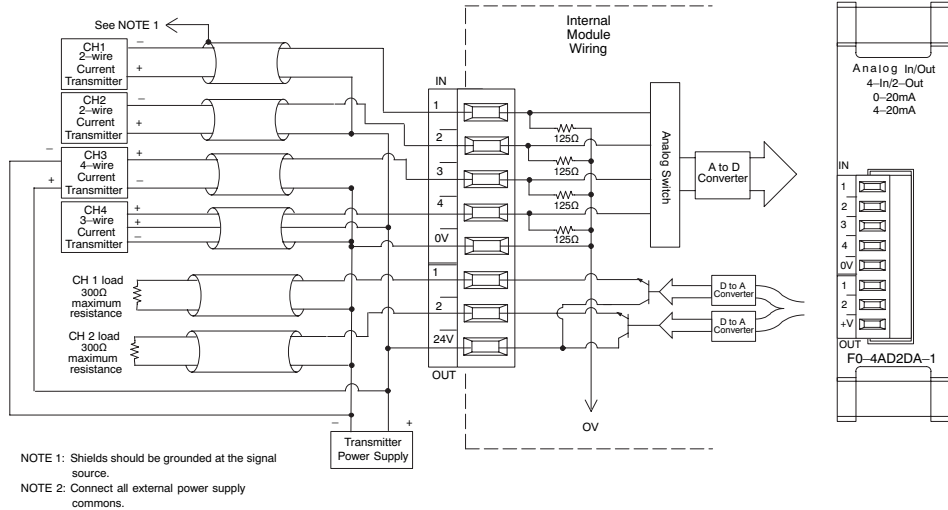

Current Loop Transmitter Impedance

Manufacturers of transmitters and transducers specify a wide variety of power sources for their products. Follow the manufacturer's recommendations.

In some cases, manufacturers specify a minimum loop or load resistance that must be used with the transmitter. The F0-04AD2DA-1 provides 125 ohm resistance for each channel. If your transmitter requires a load resistance below 125 ohms, you do not have to make any changes. However, if your transmitter requires a load resistance higher than 125 ohms, you need to add a resistor in series with the module.

Consider the following example for a transmitter being operated from a 30VDC supply with a recommended load resistance of 750 ohms. Since the module has a 125 ohm resistor, you need to add an additional resistor.

$$R = Tr - Mr$$

$$R = 750 - 125$$

$$R \geq 625$$

R = resistor to add
 Tr = Transmitter Requirement
 Mr = Module resistance (internal 125 ohms)

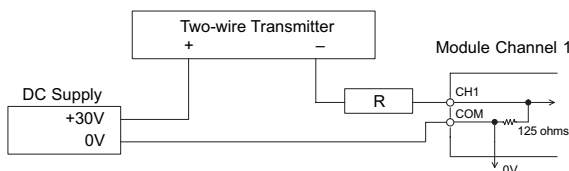

Module Operation

Input/Output Channel Update Sequence

The DL05 and DL06 will read four channels of input data and two channels of output data during each scan. Each CPU supports special V-memory locations that are used to manage the data transfer. This is discussed in more detail beginning on the next page, “Special V-memory Locations”.

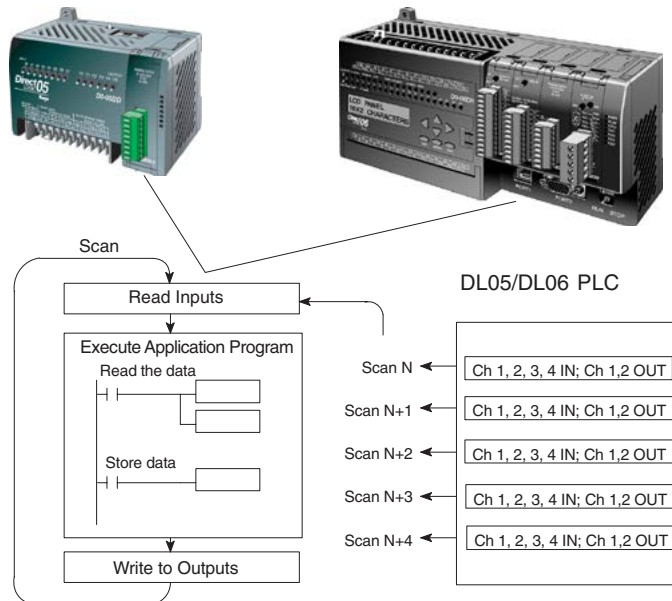

Analog Module Updates

Even though the channel updates to the CPU are synchronous with the CPU scan, the module asynchronously monitors the analog transmitter signals and converts each signal into a 12-bit binary representation. This enables the module to continuously provide accurate measurements without slowing down the discrete control logic in the RLL program.

The module takes approximately 25 milliseconds to sense 95% of the change in the analog signal. For the vast majority of applications, the process changes are much slower than these updates.



NOTE: If you are comparing other manufacturers' update times (step responses) with ours, please be aware that some manufacturers refer to the time it takes to convert the analog signal to a digital value. Our analog to digital conversion takes only a few microseconds. It is the settling time of the filter that is critical in determining the full update time. Our update time specification includes the filter settling time.

Special V-memory Locations

Formatting the Module Data

The DL05 and DL06 PLCs have three special V-memory locations assigned to their respective option slots. These V-memory locations allow you to:

- Specify the data format (binary or BCD)
- Specify the number of input and output channels to scan.
- Specify the V-memory locations to store the input data
- Specify the V-memory locations to store the output data

DL05 Data Formatting

The table below shows the special V-memory locations used by the DL05 PLC for the analog combination module.

Analog Combination Module DL05 Special V-memory Locations	
Data Type and Number of I/O Channels	V7700
Input Storage Pointer	V7701
Output Storage Pointer	V7702

Structure of V7700

V-memory location 7700 is used for identifying the number of output channels, the number of input channels and the data type (binary or BCD). The low byte equals the number of output channels and the high byte equals the number of input channels. Enter a 1 through 4 to select the number of input channels and a 1 through 2 to select the number of output channels to be used. A zero (0) entered for channel selection will cause the channel, either input or output, to be inoperative.

Loading a constant of 402 into V7700 identifies four input and two output analog channels, and sets the I/O data type to BCD.

Loading a constant of 8482 into V7700 identifies four input and two output analog channels, and sets the I/O data type to binary.

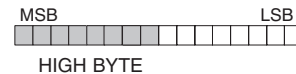

Structure of V7701

V7701 is a system parameter that points to a V-memory location used for storing analog input data. The V-memory location loaded in V7701 is an octal number identifying the first V-memory location for the analog input data. This V-memory location is user selectable. For example, loading O2000 causes the pointer to write Ch 1's data value to V2000, Ch 2's data value to V2001, CH 3's data value to V2002 and Ch 4's data value to V2003.

Structure of V7702

V7702 is a system parameter that points to a V-memory location used for storing analog output data. The V-memory location loaded in V7702 is an octal number identifying the first V-memory location for the analog output data. This V-memory location is user selectable. For example, loading O2010 causes the pointer to read Ch 1's data value at V2010 and Ch 2's data value at V2011.

You will find an example program that loads appropriate values to V7700, V7701 and V7702 on page 11-11.

DL06 Data Formatting

Special V-memory locations are assigned to the four option module slots of the DL06 PLC. The table below shows these V-memory locations which can be used by the F0-4AD2DA-1.

Analog Combination Module DL06 Special V-memory Locations				
Slot No.	1	2	3	4
Data Type and Number of Channels	V700	V710	V720	V730
Input Storage Pointer	V701	V711	V721	V731
Output Storage Pointer	V702	V712	V722	V732

Setup Data Type and Number of Channels

V-memory locations 700, 710, 720 and 730 are used to set the number of output channels, the number of input channels and the data type (binary or BCD). The low byte equals the number of output channels and the high byte equals the number of input channels. Enter a 1 through 4 to select the number of input channels and a 1 through 2 to select the number of output channels to be used. A zero (0) entered for channel selection will cause the channel, either input or output, to be inoperative.

Consider the F0-4AD2DA-1 to be installed in slot 2. Loading a constant of 402 into V710 identifies four input and two output analog channels, and sets the I/O data type to BCD.

Loading a constant of 8482 into V710 identifies four input and two output analog channels, and sets the I/O data type to binary.

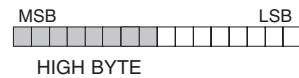

Input Storage Pointer Setup

V-memory locations 701, 711, 721 and 731 are special locations used as a storage pointer for the analog input data. With the analog module installed in slot 2, the V-memory location loaded in V711 is an octal number identifying the first user V-memory location to write the analog input data to. This V-memory location is user selectable. For example, loading O2000 causes the pointer to write Ch 1's data value to V2000, Ch 2's data value to V2001, CH 3's data value to V2002 and Ch 4's data value to V2003.

Output Storage Pointer Setup

V-memory locations 702, 712, 722 and 732 are special locations used as a storage pointer for the analog output data. With the analog module installed in slot 2, the V-memory location loaded in V712 is an octal number identifying the first user V-memory location to read the analog output data from. This V-memory location is user selectable. For example, loading O2010 causes the pointer to read Ch 1's data value at V2010 and Ch 2's data value at V2011.

You will find an example program that loads appropriate values to V710, V711 and V712 on page 11-12.

Using the Pointer in Your Control Program

DL05 Pointer Method

The DL05 CPU examines the pointer values (the memory locations identified in V7700, V7701 and V7702) on the first scan only.

The example program below shows how to setup these locations for 4 input channels and 2 output channels. This rung can be placed anywhere in the ladder program or in the initial stage if you are using stage programming instructions.

This is all that is required to read the analog input and output data into V-memory locations. Once the data is in V-memory you can perform math on the data, compare the data against preset values, and so forth. V2000 and V2010 are used in the example, the V-memory locations are user selectable.

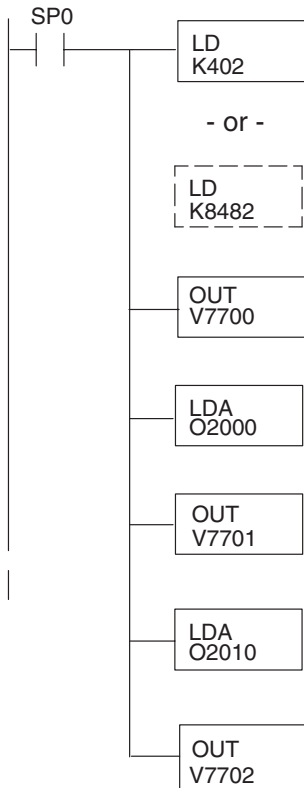

Loads a constant that specifies the number of channels to scan and the data format. The upper byte selects the input data format (i.e. 0=BCD, 8=Binary) and the number of input channels (set to 4). The lower byte selects the output data format (i.e. 0=BCD, 8=Binary) and the number of output channels (set to 2).

The binary format is used for displaying data on some operator interface units. The DL05 PLCs support binary math functions.

Special V-memory location assigned to the option slot contains the data format and the number of channels to scan.

This loads an octal value for the first V-memory location that will be used to store the incoming data. For example, the O2000 entered here would designate the following addresses:

Ch1 – V2000, Ch2 – V2001, Ch3 – V2002, Ch4 – V2003

The octal address (O2000) is stored here. V7701 is assigned to the option slot and acts as a pointer, which means the CPU will use the octal value in this location to determine exactly where to store the incoming data.

This loads an octal value for the first V-memory location that will be used to store the output data. For example, the O2010 entered here would designate the following addresses:

Ch1 – V2010, Ch2 – V2011

The octal address (O2010) is stored here. V7702 is assigned to the option slot and acts as a pointer, which means the CPU will use the octal value in this location to determine exactly where to get the output data.

DL06 Pointer Method

Use the special V-memory table as a guide to setup the pointer values in the following example for the DL06. Slot 1 is the left most option slot. The CPU will examine the pointer values at these locations only after a mode transition, first scan only.

Analog Combination Module DL06 Special V-memory Locations				
Slot No.	1	2	3	4
No. of Channels	V700	V710	V720	V730
Input Pointer	V701	V711	V721	V731
Output Pointer	V702	V712	V722	V732

The F0-4AD2DA-1 can be installed in any available DL06 option slot. Using the example program from the previous page, but changing the V-memory addresses, the ladder diagram below shows how to setup these locations for 4 input channels and 2 output channels with the module installed in slot 2 of the DL06. Use the above table to determine the pointer values if locating the module in any of the other slot locations. Place this rung anywhere in the ladder program or in the initial stage if you are using stage programming instructions.

Like the DL05 example, this logic is all that is required to read the analog input data into V-memory locations. Once the data is in V-memory you can perform mathematical calculations with the data, compare the data against preset values, and so forth. V2000 and V2010 is used in the example but you can use any user V-memory location.

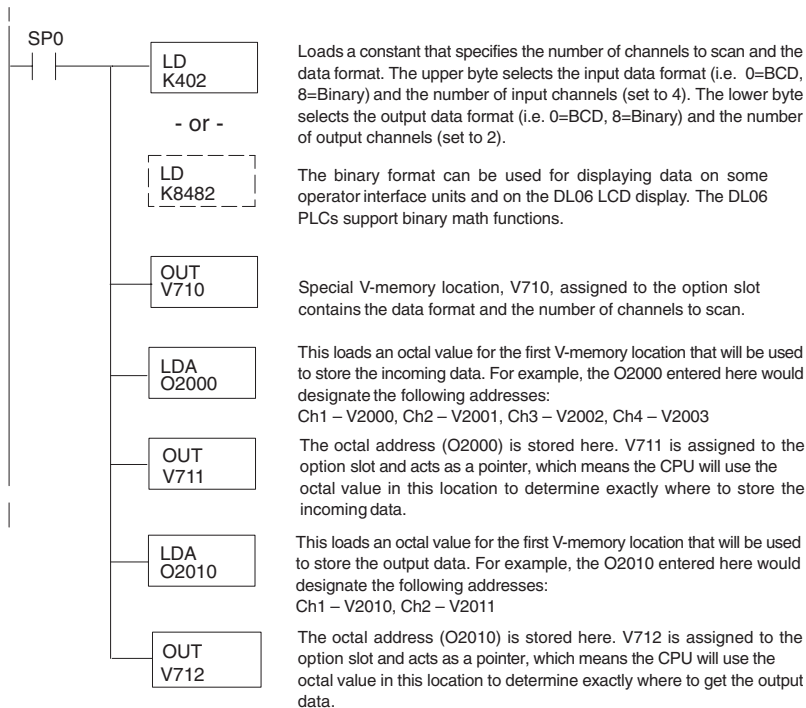

Scale Conversions

Scaling the Input Data

Many applications call for measurements in engineering units, which can be more meaningful than raw data. Convert to engineering units using the formula shown to the right.

You may have to make adjustments to the formula depending on the scale you choose for the engineering units.

For example, if you wanted to measure pressure (PSI) from 0.0 to 100.0 then you would have to multiply the analog value by 10 in order to imply a decimal place when you view the value with the programming software or a handheld programmer. Notice how the calculations differ when you use the multiplier.

Analog Value of 2024, slightly less than half scale, should yield 49.4 PSI

$$\text{Units} = A \frac{H-L}{4095} + L$$

H = High limit of the engineering unit range

L = Low limit of the engineering unit range

A = Analog value (0 – 4095)

Example without multiplier

$$\text{Units} = A \frac{H-L}{4095} + L$$

$$\text{Units} = 2024 \frac{100-0}{4095} + 0$$

$$\text{Units} = 49$$

Example with multiplier

$$\text{Units} = 10 A \frac{H-L}{4095} + L$$

$$\text{Units} = 20240 \frac{100-0}{4095} + 0$$

$$\text{Units} = 494$$

The Conversion Program

The following example shows how you would write the program to perform the engineering unit conversion from input data formats 0–4095. This example assumes the raw input data read at V2000 is in BCD format.

Note: this example uses SP1, which is always on. You could also use an X, C, etc., permissive contact.

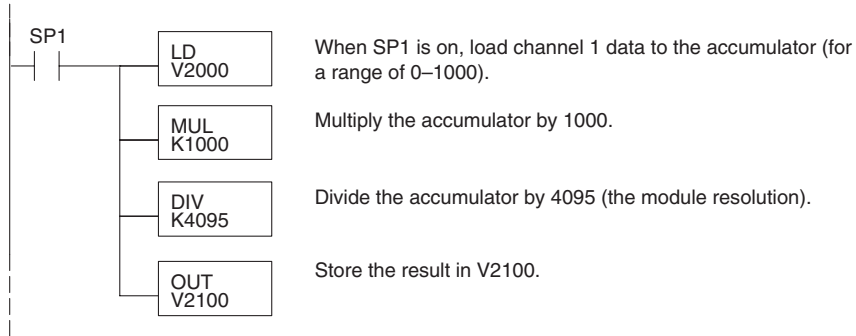

Output Conversion Program

The following example program shows how you would write the program to perform the engineering unit conversion to output data formats 0–4095. This example assumes you have calculated or loaded the engineering unit values between 0–1000 in BCD format and stored them in V2300 and V2301 for channels 1 and 2 respectively. Both the DL05 and DL06 offer instructions that allow you to perform math operations using BCD format. It is usually easier to perform any math calculations in BCD and then convert the value to binary before you send the data to the module.

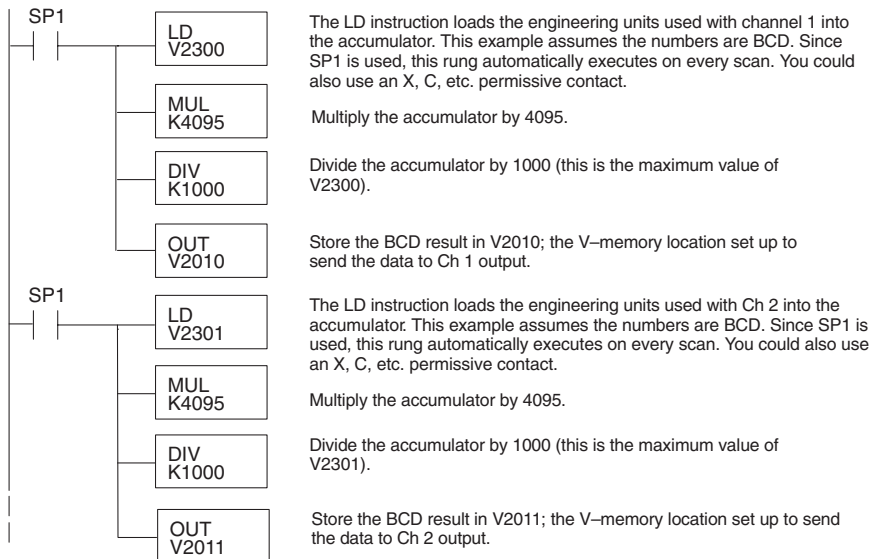

Analog and Digital Value Conversions

Sometimes it is useful to convert between the signal levels and the digital values. This is especially helpful during machine startup or troubleshooting. The following tables provide formulas to make this conversion easier.

Range	If you know the digital value	If you know the analog signal level
4 to 20mA	$A = \frac{16D}{4095} + 4$	$D = \frac{4095}{16} (A - 4)$

For example, if you have measured the signal as 10mA, you can use the formula to determine the digital value (D) that will be stored in the V-memory location that contains the data.

$$D = \frac{4095}{16} (A - 4)$$

$$D = \frac{4095}{16} (10\text{mA} - 4)$$

$$D = (255.93) (6)$$

$$D = 1536$$

Range	If you know the digital value	If you know the analog signal level
0 to 20mA	$A = \frac{20D}{4095}$	$D = \frac{4095}{20} (A)$

This example shows the result for the 0 to 20mA range.

$$D = \frac{4095}{20} (A)$$

$$D = \frac{4095}{20} (10\text{mA})$$

$$D = (204.75) (10)$$

$$D = 2047.5$$

Special Relays

The list of other Special Relays associated with the DL05 and DL06 PLCs are contained in the DL05 User Manual and the DL06 User Manual. The following special relays are new and relate to the status of the F0-04AD2DA-1 module or one of its input channels.

DL05 Special Relays

DL05 Special Relays			
SP600	Chan 1 input type	0 = 0-20mA	1 = 4-20mA
SP601	Chan 2 input type	0 = 0-20mA	1 = 4-20mA
SP602	Chan 3 input type	0 = 0-20mA	1 = 4-20mA
SP603	Chan 4 input type	0 = 0-20mA	1 = 4-20mA
SP610	Chan 1 input open	1 = xmitter signal open	0 = xmitter signal good
SP611	Chan 2 input open	1 = xmitter signal open	0 = xmitter signal good
SP612	Chan 3 input open	1 = xmitter signal open	0 = xmitter signal good
SP613	Chan 4 input open	1 = xmitter signal open	0 = xmitter signal good

DL06 Special Relays

DL06 Special Relays			
SLOT 1			
SP140	Chan 1 input type	0 = 0-20mA	1 = 4-20mA
SP141	Chan 2 input type	0 = 0-20mA	1 = 4-20mA
SP142	Chan 3 input type	0 = 0-20mA	1 = 4-20mA
SP143	Chan 4 input type	0 = 0-20mA	1 = 4-20mA
SP150	Chan 1 input open	1 = xmitter signal open	0 = xmitter signal good
SP151	Chan 2 input open	1 = xmitter signal open	0 = xmitter signal good
SP152	Chan 3 input open	1 = xmitter signal open	0 = xmitter signal good
SP153	Chan 4 input open	1 = xmitter signal open	0 = xmitter signal good

SLOT 2			
SP240	Chan 1 input type	0 = 0-20mA	1 = 4-20mA
SP241	Chan 2 input type	0 = 0-20mA	1 = 4-20mA
SP242	Chan 3 input type	0 = 0-20mA	1 = 4-20mA
SP243	Chan 4 input type	0 = 0-20mA	1 = 4-20mA
SP250	Chan 1 input open	1 = xmitter signal open	0 = xmitter signal good
SP251	Chan 2 input open	1 = xmitter signal open	0 = xmitter signal good
SP252	Chan 3 input open	1 = xmitter signal open	0 = xmitter signal good
SP253	Chan 4 input open	1 = xmitter signal open	0 = xmitter signal good

DL06 Special Relays (cont'd)			
SLOT 3			
SP340	Chan 1 input type	0 = 0–20 mA	1 = 4–20 mA
SP341	Chan 2 input type	0 = 0–20 mA	1 = 4–20 mA
SP342	Chan 3 input type	0 = 0–20 mA	1 = 4–20 mA
SP343	Chan 4 input type	0 = 0–20 mA	1 = 4–20 mA
SP350	Chan 1 input open	1 = xmitter signal open	0 = xmitter signal good
SP351	Chan 2 input open	1 = xmitter signal open	0 = xmitter signal good
SP352	Chan 3 input open	1 = xmitter signal open	0 = xmitter signal good
SP353	Chan 4 input open	1 = xmitter signal open	0 = xmitter signal good

SLOT 4			
SP440	Chan 1 input type	0 = 0–20 mA	1 = 4–20 mA
SP441	Chan 2 input type	0 = 0–20 mA	1 = 4–20 mA
SP442	Chan 3 input type	0 = 0–20 mA	1 = 4–20 mA
SP443	Chan 4 input type	0 = 0–20 mA	1 = 4–20 mA
SP450	Chan 1 input open	1 = xmitter signal open	0 = xmitter signal good
SP451	Chan 2 input open	1 = xmitter signal open	0 = xmitter signal good
SP452	Chan 3 input open	1 = xmitter signal open	0 = xmitter signal good
SP453	Chan 4 input open	1 = xmitter signal open	0 = xmitter signal good

Module Resolution

Analog Data Bits

The first twelve bits represent the analog data in binary format.

Bit	Value	Bit	Value
0	1	6	64
1	2	7	128
2	4	8	256
3	8	9	512
4	16	10	1024
5	32	11	2048

MSB												LSB											
						1	1	9	8	7	6	5	4	3	2	1	0						
						1	0																

□ = data bits

Resolution Details

Since the module has 12-bit resolution, the analog signal is converted from 4096 counts ranging from 0–4095 (2^{12}). For example, a 4mA signal would be 0 and 20mA signal would be 4095. This is equivalent to a binary value of 0000 0000 0000 to 1111 1111 1111, or 000 to FFF hexadecimal. The diagrams below show how this relates to the two signal ranges.

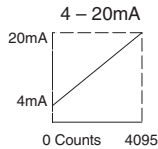

$$\text{Resolution} = \frac{H - L}{4095}$$

H = high limit of the signal range

L = low limit of the signal range

$$16\text{mA} / 4095 = 3.907\mu\text{A per count}$$

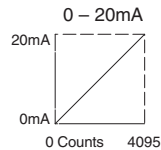

$$20\text{mA} / 4095 = 4.884\mu\text{A per count}$$

Analog Input Ladder Logic Filter

PID Loops / Filtering

Please refer to the “PID Loop Operation” chapter in the DL06 or DL05 User Manual for information on the built-in PV filter (DL05/06) and the ladder logic filter (DL06 only) shown below. A filter must be used to smooth the analog input value when auto tuning PID loops to prevent giving a false indication of loop characteristics.

Smoothing the Input Signal (DL06 only)

The filter logic can also be used in the same way to smooth the analog input signal to help stabilize PID loop operation or to stabilize the analog input signal value for use with an operator interface display, etc.



WARNING: The built-in and logic filters are not intended to smooth or filter noise generated by improper field device wiring or grounding. Small amounts of electrical noise can cause the input signal to bounce considerably. Proper field device wiring and grounding must be done before attempting to use the filters to smooth the analog input signal.

Using Binary Data Format

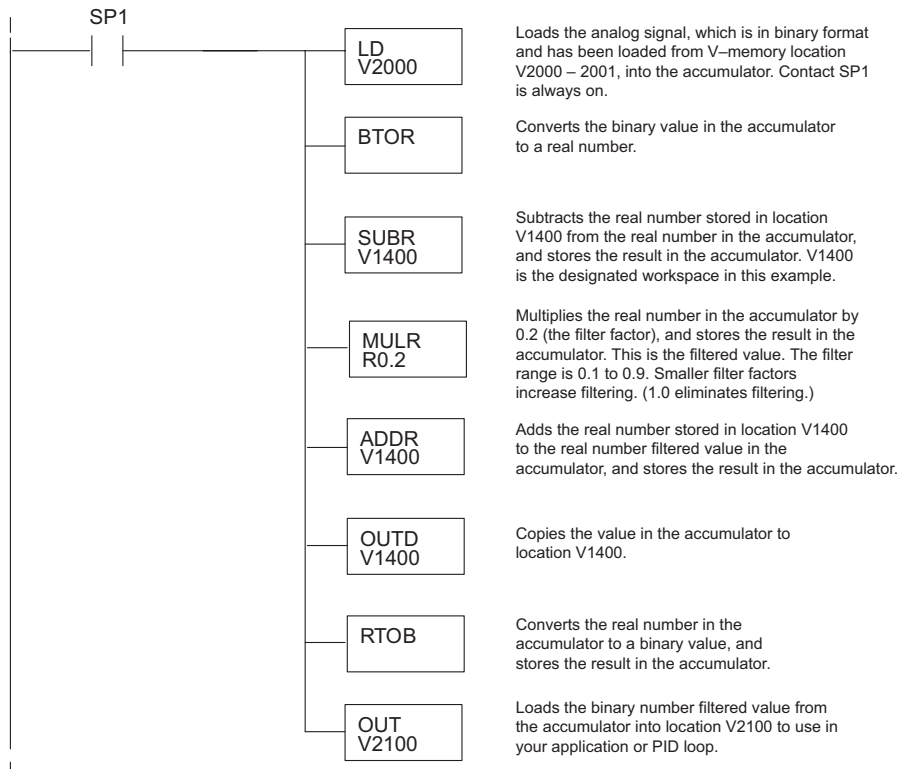



NOTE: Be careful not to do a multiple number conversion on a value. For example, if you are using the pointer method in BCD format to get the analog value, it must be converted to binary (BIN) as shown below. If you are using the pointer method in Binary format, the conversion to binary (BIN) instruction is not needed.

Using BCD Data Format

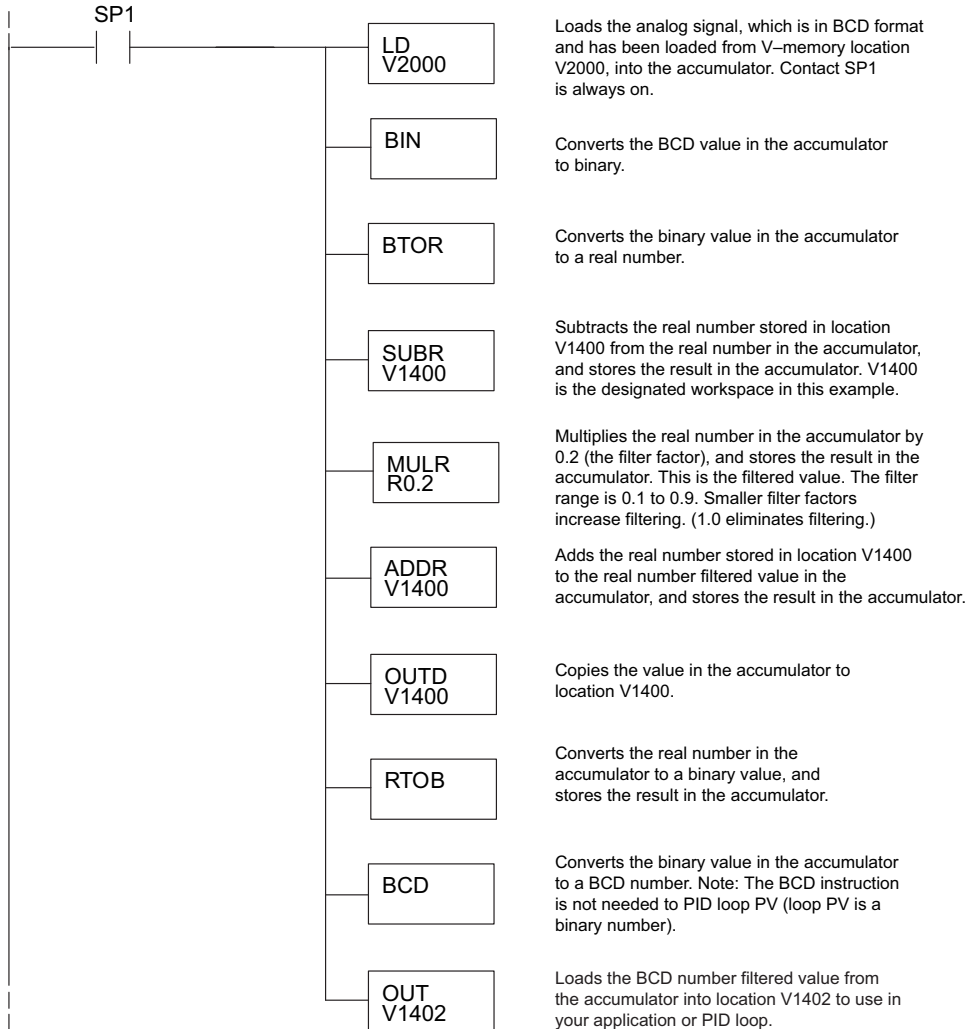

F0-2AD2DA-2 2-CH. IN/2-CH. OUT ANALOG VOLTAGE COMBINATION



In This Chapter...

Module Specifications	12-2
Setting the Module Jumpers	12-4
Connecting and Disconnecting the Field Wiring	12-5
Wiring Diagram	12-5
Module Operation	12-6
Special V-memory Locations	12-7
Using the Pointer in Your Control Program	12-10
Scale Conversions	12-12
Module Resolution.....	12-15
Analog Input Ladder Logic Filter	12-16

Module Specifications

The F0-2AD2DA-2 Analog Combination module offers the following features: The analog input and output channels are updated in one scan.

- The module has a removable terminal block which makes it possible to remove the module without disconnecting the field wiring.
- Analog inputs can be used as process variables for the four (4) PID loops in the DL05 and the eight (8) PID loops in the DL06 CPUs.
- On-board active analog filtering and RISC-like microcontroller provide digital signal processing to maintain precise analog measurements in noisy environments.

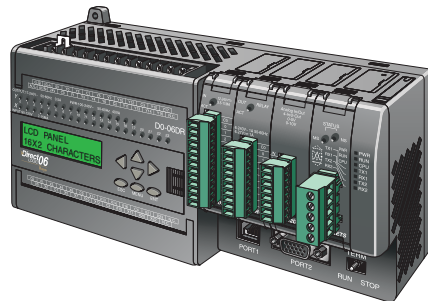

NOTE: The DL05 CPU's analog feature for this module requires **DirectSOFT32** Version 3.0c (or later) and firmware version 3.30 (or later). The DL06 requires **DirectSOFT32** version V4.0, build 16 (or later) and firmware version 1.00 (or later). See our website for more information: www.automationdirect.com.

The following tables provide the specifications for the F0-2AD2DA-2 Analog Voltage Combination Module. Review these specifications to make sure the module meets your application requirements.

Input Specifications	
Number of Channels	2, single ended (one common)
Input Range	0 to 5VDC or 0 to 10VDC (jumper selectable)
Resolution	12 bit (1 in 4096)
Step Response	10.0 ms to 95% of full step change
Crosstalk	1/2 count maximum (-80db)*
Active Low-pass Filtering	-3dB at 300Hz (-12dB per octave)
Input Impedance	Greater than 20k Ω
Absolute Maximum Ratings	$\pm 15V$
Linearity Error (End to End)	± 2 counts (0.025% of full scale) maximum*
Input Stability	± 1 count *
Gain Error	± 6 counts *
Offset Error	± 2 counts *
Maximum Inaccuracy	0.3% @ 25°C (77°F)
	0.6% 0 to 60°C (32 to 140°F)
Accuracy vs. Temperature	± 100 ppm/°C typical

Output Specifications	
Number of Channels	2, single ended (one common)
Output Range	0 to 5VDC or 0 to 10VDC (jumper selectable)
Resolution	12 bit (1 in 4096)
Conversion Settling Time	50 μ S for full scale change
Crosstalk	1/2 count maximum (-80db) *
Peak Output Voltage	$\pm 15VDC$ (power supply limited)
Offset Error	0.1% of range
Gain Error	0.4% of range
Linearity Error (end to end)	± 1 count (0.075% of full scale) maximum*
Output Stability	± 2 counts*
Load Impedance	2k Ω minimum
Load Capacitance	0.01 μ F maximum
Accuracy vs. Temperature	± 50 ppm/°C typical

* One count in the specification table is equal to one least significant bit of the analog data value (1 in 4096).

General Specifications	
PLC Update Rate	2 input channels per scan 2 output channels per scan
16-bit Data Word	12 binary data bits
Operating Temperature	0 to 60° C (32 to 140° F)
Storage Temperature	-20 to 70° C (-4 to 158° F)
Relative Humidity	5 to 95% (non-condensing)
Environmental Air	No corrosive gases permitted
Vibration	MIL STD 810C 514.2
Shock	MIL STD 810C 516.2
Noise Immunity	NEMA ICS3-304
Power Budget Requirement	50mA @ 5VDC (supplied by base)
External Power Supply	30mA, 24VDC ±10%
Connector	Phoenix Mecano, Inc. Part No. AK1550/8-3.5 - green
Connector Wire Size	28–16 AWG
Connector Screw Torque	3.5 inch-pounds (0.4 N-m)
Connector Screwdriver Size	DN-SS1 (recommended)

Setting the Module Jumpers

The position of the J2 jumpers determines the input and output signal levels. You can choose between 0–5 VDC or 0–10 VDC. The module ships with the jumpers connecting the pins. In this position, the input and output signal level is 0–5 VDC. To select 0–10 VDC signals, use the jumper setting chart located on the module. One or more channels can be selected for 0–10 VDC input and output signal level by removing the jumper from the connecting pins of the appropriate channel. This will allow you to have one channel selected for a 0–5 VDC signal and another channel selected for a 0–10 VDC signal.

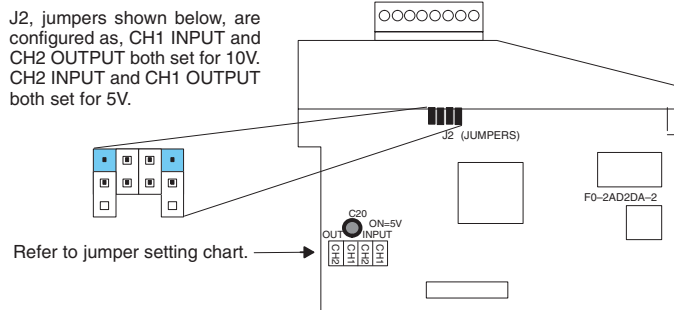

WARNING: Before removing the analog module or the terminal block on the face of the module, disconnect power to the PLC and all field devices. Failure to disconnect power can result in damage to the PLC and/or field devices.

Connecting and Disconnecting the Field Wiring

Wiring Guidelines

Your company may have guidelines for wiring and cable installation. If so, you should check those before you begin the installation. Here are some general things to consider:

- Use the shortest wiring route whenever possible.
- Use shielded wiring and ground the shield at the transmitter source. *Do not* ground the shield at both the module and the source.
- Do not run the signal wiring next to large motors, high current switches, or transformers. This may cause noise problems.
- Route the wiring through an approved cable housing to minimize the risk of accidental damage. Check local and national codes to choose the correct method for your application.

The F0-2AD2DA-2 will require an external power supply with a rating of 18.0-26.4 VDC at 30mA.

To remove the terminal block, disconnect power to the PLC and the field devices. Pull the terminal block firmly until the connector separates from the module.

You can remove the analog module from the PLC by folding out the retaining tabs at the top and bottom of the module. As the retaining tabs pivot upward and outward, the module's connector is lifted out of the PLC socket. Once the connector is free, you can lift the module out of its slot.

Wiring Diagram

Use the following diagram to connect the field wiring. If necessary, the F0-2AD2DA-2 terminal block can be removed to make removal of the module possible without disturbing field wiring.

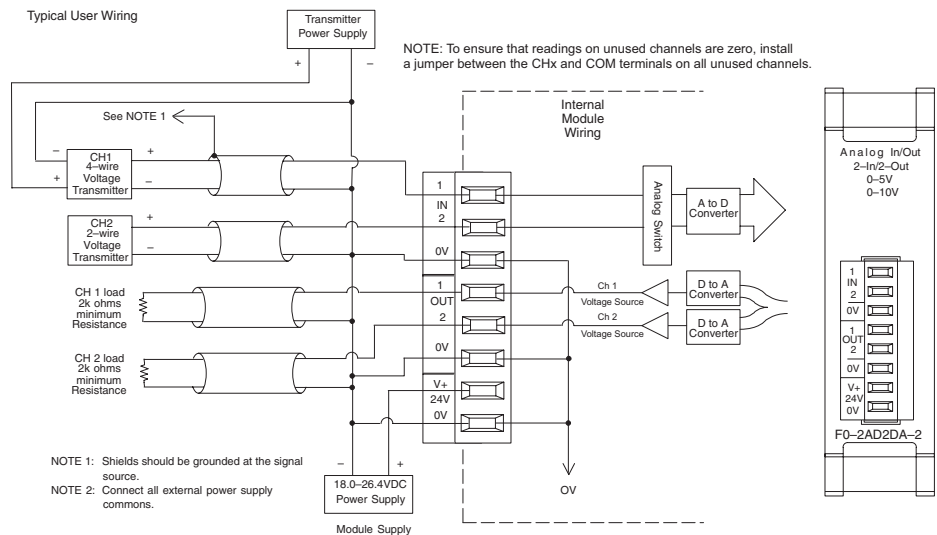

Module Operation

Input/Output Channel Scanning Sequence

The DL05 and DL06 read two channels of input and two channels of output data during each scan. The CPU supports special V-memory locations that are used to manage the data transfer. This is discussed in more detail on the following page, “Special V-memory Locations”.

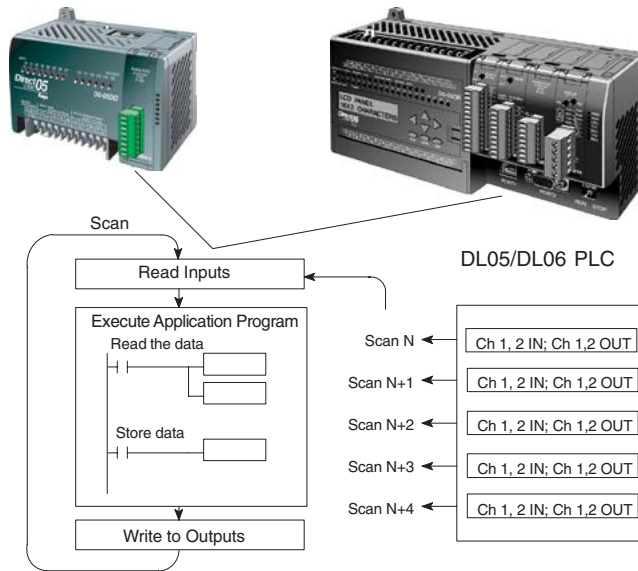

Analog Module Updates

Even though the channel updates to the CPU are synchronous with the CPU scan, the module asynchronously monitors the analog transmitter signals and converts each signal into a 12-bit binary representation. This enables the module to continuously provide accurate measurements without slowing down the discrete control logic in the RLL program.

The module takes approximately 10 milliseconds to sense 95% of the change in the analog signal. For the vast majority of applications, the process changes are much slower than these updates.



NOTE: If you are comparing other manufacturers' update times (step responses) with ours, please be aware that some manufacturers refer to the time it takes to convert the analog signal to a digital value. Our analog to digital conversion takes only a few microseconds. It is the settling time of the filter that is critical in determining the full update time. Our update time specification includes the filter settling time.

Special V-memory Locations

Formatting the Module Data

The DL05 and DL06 PLCs have three special V-memory locations assigned to their respective option slots. These V-memory locations allow you to:

- Specify the data format (binary or BCD)
- Specify the number of I/O channels to scan (2 input and 2 output channels for the F0-2AD2DA-2)
- Specify the V-memory locations to store the input data
- Specify the V-memory locations to store the output data

DL05 Data Formatting

The table below shows the special V-memory locations used by the DL05 PLC for the analog combination modules.

Analog Combination Module DL05 Special V-memory Locations	
Data Type and Number of I/O Channels	V7700
Input Storage Pointer	V7701
Output Storage Pointer	V7702

Structure of V7700

V-memory location 7700 is used for identifying the number of output channels, the number of input channels and the data type (binary or BCD). The low byte equals the number of output channels and the high byte equals the number of input channels. Either a 1 or a 2 will be entered to select the number of input and output channels to be used. A zero (0) entered for channel selection will cause the channel, either input or output, to be inoperative.

Loading a constant of 202 into V7700 identifies two input and two output analog channels, and sets the I/O data type to BCD.

Loading a constant of 8282 into V7700 identifies two input and two output analog channels, and sets the I/O data type to binary.

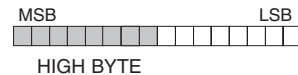

Structure of V7701

V7701 is a system parameter that points to a V-memory location used for storing analog input data. The V-memory location loaded in V7701 is an octal number identifying the first V-memory location for the analog input data. This V-memory location is user selectable. For example, loading O2000, using the LDA instruction, causes the pointer to write Ch 1's data value to V2000 and Ch 2's data value to V2001.

Structure of V7702

V7702 is a system parameter that points to a V-memory location used for storing analog output data. The V-memory location loaded in V7702 is an octal number identifying the first V-memory location for the analog output data. This V-memory location is user selectable. For example, loading O2010, using the LDA instruction, causes the pointer to write Ch 1's data value from V2010 and Ch 2's data value from V2011.

You will find an example program that loads appropriate values to V7700, V7701 and V7702 on page 12-10.

DL06 Data Formatting

Special V-memory locations are assigned to the four option module slots of the DL06 PLC. The table below shows these V-memory locations which can be used by the F0-2AD2DA-2.

Analog Combination Module DL06 Special V-memory Locations				
Slot No.	1	2	3	4
Number of Channels	V700	V710	V720	V730
Input Pointer	V701	V711	V721	V731
Output Pointer	V702	V712	V722	V732

Setup Data Type and Number of Channels

V-memory locations 700, 710, 720 and 730 are used for identifying the number of output channels, the number of input channels and the data type (binary or BCD). The low byte equals the number of output channels and the high byte equals the number of input channels. Enter a 1 or 2 to select the number of input and output channels to be used. A zero (0) entered for channel selection will cause the channel, either input or output, to be inoperative.

For example, with a module installed in slot 1 by loading a constant of 202 into V700 identifies two input and two output analog channels, and sets the I/O data type to BCD.

And, loading a constant of 8282 into V700 identifies two input and two output analog channels, and sets the I/O data type to binary.

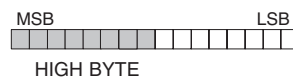

Input Storage Pointer

V-memory locations 701, 711, 721 and 731 are special locations used as a storage pointers for the analog input data. With the analog module installed in slot 1, the V-memory location loaded in V701 is an octal number identifying the first user V-memory location to read the analog input data. This V-memory location is user selectable. For example, loading O2000, using the LDA instruction, causes the pointer to write Ch 1's data value to V2000 and Ch 2's data value to V2001.

Output Storage Pointer

V-memory locations 702, 712, 722 and 732 are special locations used as storage pointer for the analog output data. With the analog module installed in slot 1, the V-memory location loaded in V702 is an octal number identifying the first user V-memory location to write the analog output data to. This V-memory location is user selectable. For example, loading O2010, using the LDA instruction, causes the pointer to write Ch 1's data value from V2010 and Ch 2's data value from V2011.

You will find an example program that loads appropriate values to V700, V701 and V702 on page 12-11.

Using the Pointer in Your Control Program

DL05 Pointer Method

The DL05 CPU examines the pointer values (the memory locations identified in V7700, V7701 and V7702) on the first scan only.

The example program below shows how to setup these locations for 2 input channels and 2 output channels. This rung can be placed anywhere in the ladder program or in the initial stage if you are using stage programming instructions.

This is all that is required to read the analog input data into V-memory locations. Once the data is in V-memory you can perform mathematical calculations with the data, compare the data against preset values, and so forth. V2000 and V2010 is used in the example but you can use any user V-memory location.

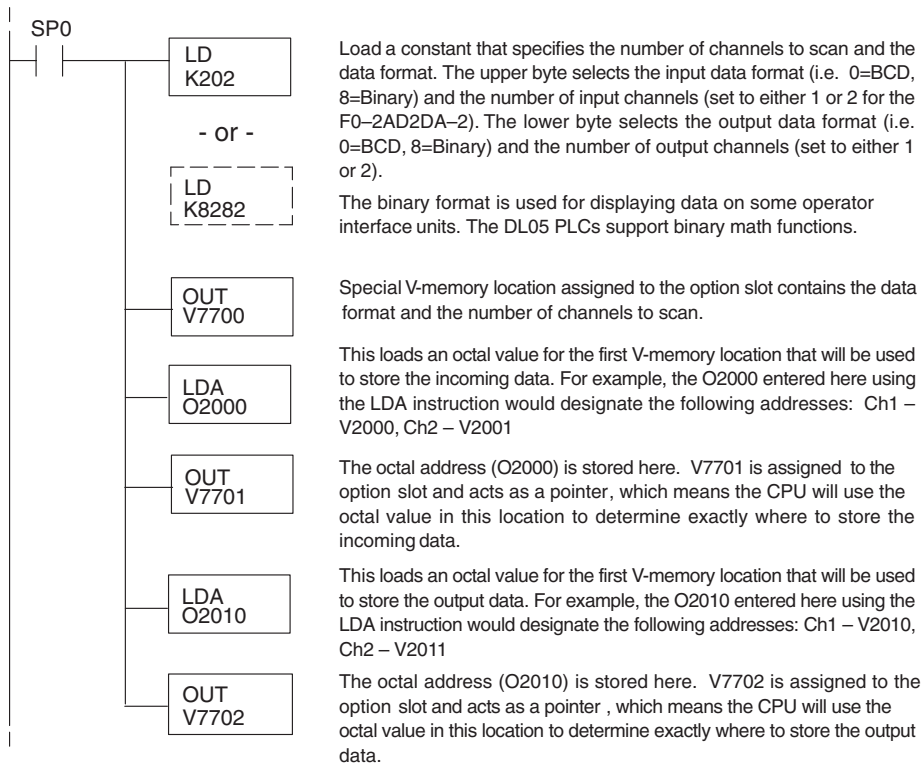

DL06 Pointer Method

Use the special V-memory table as a guide to setup the pointer values in the following example for the DL06. Slot 1 is the left most option slot. The CPU will examine the pointer values at these locations only after a mode transition, first scan only.

Analog Combination Module DL06 Special V-memory Locations				
Slot No.	1	2	3	4
Number of Channels	V700	V710	V720	V730
Input Pointer	V701	V711	V721	V731
Output Pointer	V702	V712	V722	V732

The F0-2AD2DA-2 can be installed in any available DL06 option slot. Using the example program from the previous page, but changing the V-memory addresses, the ladder diagram below shows how to setup these locations for 2 input channels and 2 output channels with the module installed in slot1 of the DL06. Use the above table to determine the pointer values if locating the module in any of the other slot locations. Place this rung anywhere in the ladder program or in the initial stage if you are using stage programming instructions.

Like the DL05 example, this logic is all that is required to read the analog input data into V-memory locations. Once the data is in V-memory you can perform mathematical calculations with the data, compare the data against preset values, and so forth. V2000 and V2010 is used in the example but you can use any user V-memory location.

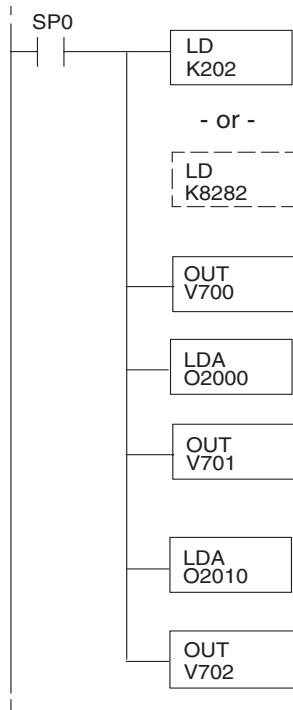

Loads a constant that specifies the number of channels to scan and the data format. The upper byte selects the input data format (i.e. 0=BCD, 8=Binary) and the number of input channels (set to either 1 or 2 for the F0-2AD2DA-2). The lower byte selects the output data format (i.e. 0=BCD, 8=Binary) and the number of output channels (set to either 1 or 2).

The binary format can be used for displaying data on some operator interface units and on the DL06 LCD display. The DL06 PLCs support binary math functions.

Special V-memory location assigned to the first option slot contains the data format and the number of channels to scan.

This loads an octal value for the first V-memory location that will be used to store the incoming data. For example, O2000 entered here using the LDA instruction would designate the following addresses: Ch1 – V2000, Ch2 – V2001

The octal address (O2000) is stored here. V701 is assigned to the first option slot and acts as a pointer, which means the CPU will use the octal value in this location to determine exactly where to store the incoming data.

This loads an octal value for the first V-memory location that will be used to store the output data. For example, O2010 entered here using the LDA instruction would designate the following addresses: Ch1 – V2010, Ch2 – V2011

The octal address (O2010) is stored here. V702 is assigned to the first first slot and acts as a pointer, which means the CPU will use the octal value in this location to determine exactly where to store the output data.

Scale Conversions

Scaling the Input Data

Many applications call for measurements in engineering units, which can be more meaningful than raw data. Convert to engineering units using the formula shown to the right.

You may have to make adjustments to the formula depending on the scale you choose for the engineering units.

For example, if you wanted to measure pressure (PSI) from 0.0 to 100.0 then you would have to multiply the analog value by 10 in order to imply a decimal place when you view the value with the programming software or a handheld programmer. Notice how the calculations differ when you use the multiplier.

$$\text{Units} = A \frac{H-L}{4095} + L$$

H = High limit of the engineering unit range

L = Low limit of the engineering unit range

A = Analog value (0 – 4095)

Analog Value of 2024, slightly less than half scale, should yield 49.4 PSI.

Example without multiplier

$$\text{Units} = A \frac{H-L}{4095} + L$$

$$\text{Units} = 2024 \frac{100-0}{4095} + 0$$

$$\text{Units} = 49$$

Example with multiplier

$$\text{Units} = 10 A \frac{H-L}{4095} + L$$

$$\text{Units} = 20240 \frac{100-0}{4095} + 0$$

$$\text{Units} = 494$$

The Conversion Program

The following example shows how you would write the program to perform the engineering unit conversion from the input data format 0–4095. This example assumes the raw input data read at V2000 is in BCD format.

Note: this example uses SP1, which is always on. You could also use an X, C, etc. permissive contact.

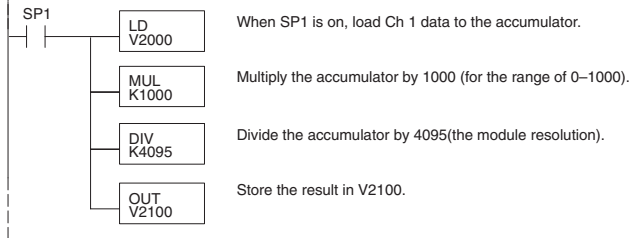

Output Conversion Program

The following example program shows how you would write the program to convert the engineering unit to the output data format 0–4095. This example assumes you have calculated or loaded the engineering unit values between 0–1000 in BCD format and stored them in V2300 and V2301 for channels 1 and 2 respectively. Both the DL05 and DL06 offer instructions that allow you to perform math operations using BCD format. It is usually easier to perform any math calculations in BCD and then convert the value to binary before you send the data to the module.

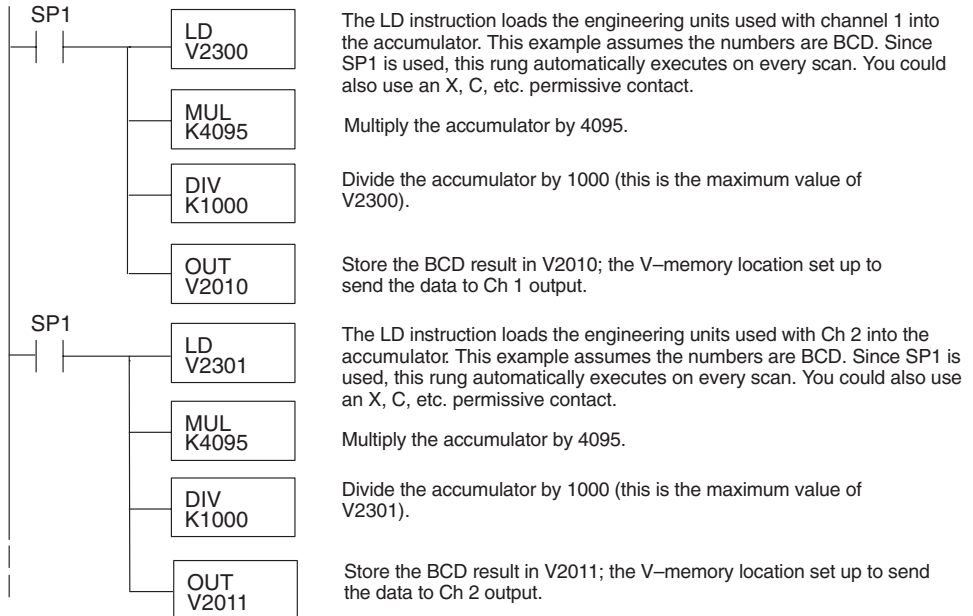

Analog and Digital Value Conversions

Sometimes it is useful to convert between the signal levels and the digital values. This is especially helpful during machine startup or troubleshooting. The following table provides formulas to make this conversion easier.

Range	If you know the digital value	If you know the analog signal level
0 to 5V	$A = \frac{5D}{4095}$	$D = \frac{4095}{5} (A)$
0 to 10V	$A = \frac{10D}{4095}$	$D = \frac{4095}{10} (A)$

For example, if you are using the 0–10V range and you need a 6V signal level, use this formula to determine the digital value (D) that will be stored in the V-memory location that contains the data.

$$D = \frac{4095}{10} (A)$$

$$D = \frac{4095}{10} (6V)$$

$$D = (409.5) (6) \qquad D = 2457$$

Module Resolution

Analog Data Bits

The first twelve bits represent the analog data for both inputs and outputs in binary format.

Bit	Value	Bit	Value
0	1	6	64
1	2	7	128
2	4	8	256
3	8	9	512
4	16	10	1024
5	32	11	2048

MSB												LSB											
[] [] [] [] [] [] [] [] [] [] [] []												[] [] [] [] [] [] [] [] [] [] [] []											
												1 1 9 8 7 6 5 4 3 2 1 0											
												1 0											

□ = data bits

Resolution Details

Since the module has 12-bit resolution for both inputs and outputs, the analog signal is either converted into 4096 counts or a count value will produce a proportional analog output. In either situation the count range will be from 0–4095 (2^{12}). For example, with an output range of 0 to 10V, send a 0 to get a 0V signal, and send 4095 to get a 10V signal. This is equivalent to a binary value of 0000 0000 0000 to 1111 1111 1111, or 000 to FFF hexadecimal.

Each count can also be expressed in terms of the signal level by using the following equation:

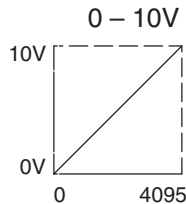

$$\text{Resolution} = \frac{H - L}{4095}$$

H = high limit of the signal range

L = low limit of the signal range

The following table shows the smallest detectable signal change that will result in one LSB change in the data or the amount of change in the output signal that each increment of the count value will produce.

Voltage Range	Signal Span	Divide By	Smallest detectable or Produced Change
0 to 5V	5 volts	4095	1.22 mV
0 to 10V	10 volts	4095	2.44 mV

Analog Input Ladder Logic Filter

PID Loops / Filtering

Please refer to the “PID Loop Operation” chapter in the DL06 or DL05 User Manual for information on the built-in PV filter (DL05/06) and the ladder logic filter (DL06 only) shown below. A filter must be used to smooth the analog input value when auto tuning PID loops to prevent giving a false indication of loop characteristics.

Smoothing the Input Signal (DL06 only)

The filter logic can also be used in the same way to smooth the analog input signal to help stabilize PID loop operation or to stabilize the analog input signal value for use with an operator interface display, etc.



WARNING: The built-in and logic filters are not intended to smooth or filter noise generated by improper field device wiring or grounding. Small amounts of electrical noise can cause the input signal to bounce considerably. Proper field device wiring and grounding must be done before attempting to use the filters to smooth the analog input signal.

Using Binary Data Format

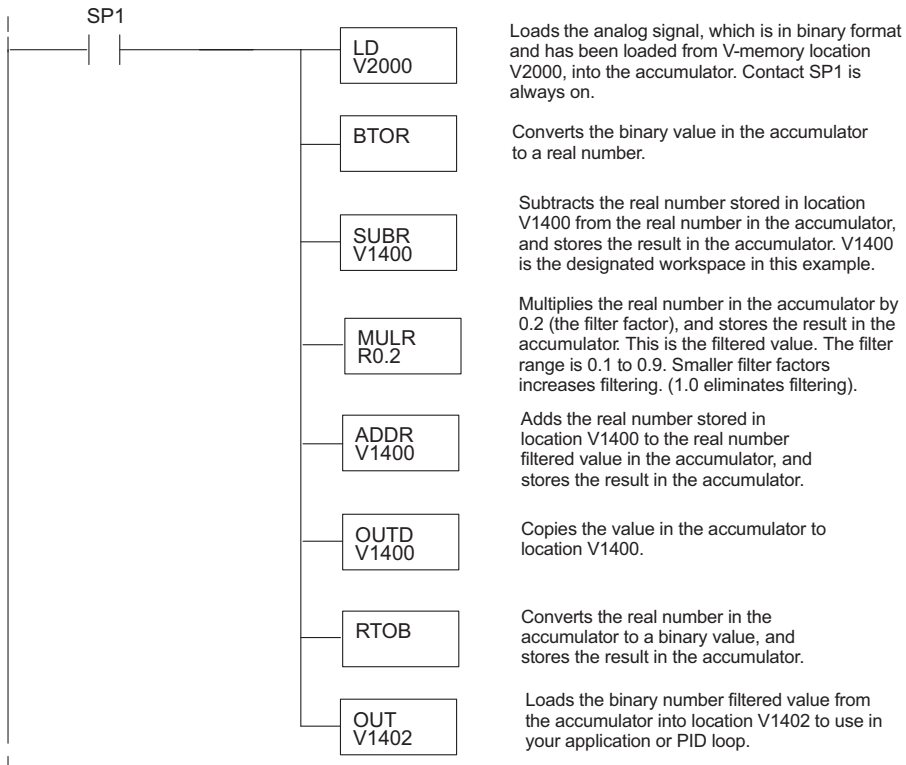



NOTE: Be careful not to do a multiple number conversion on a value. For example, if you are using the pointer method in BCD format to get the analog value, it must be converted to binary (BIN) as shown below. If you are using the pointer method in Binary format, the conversion to binary (BIN) instruction is not needed.

Using BCD Data Format

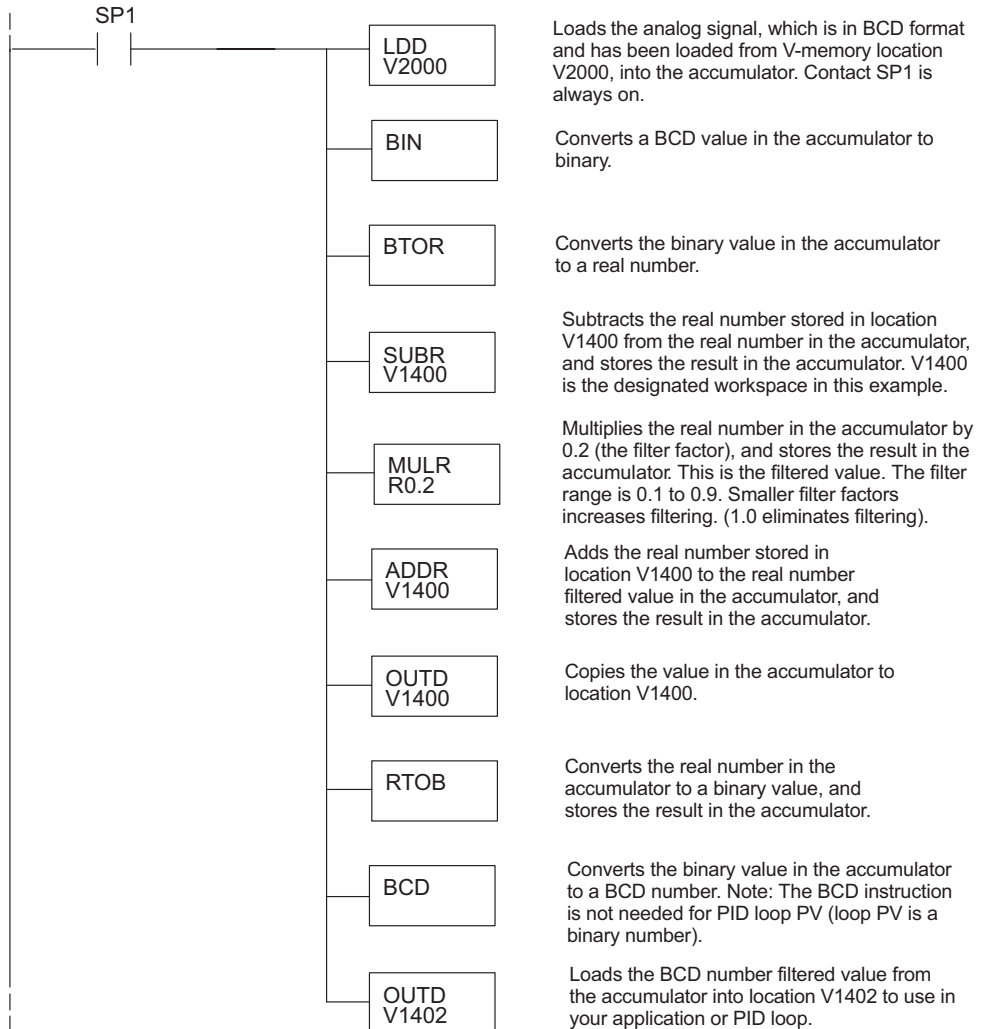

F0-4AD2DA-2, 4-Ch. IN/2-Ch. OUT ANALOG VOLTAGE COMBINATION



CHAPTER 13

In This Chapter...

Module Specifications	13-2
Setting the Module Jumpers	13-4
Connecting and Disconnecting the Field Wiring	13-5
Wiring Diagram	13-5
Module Operation	13-6
Special V-memory Locations	13-7
Using the Pointer in Your Control Program	13-10
Scale Conversions	13-12
Module Resolution.....	13-15
Analog Input Ladder Logic Filter	13-16

Module Specifications

The F0-4AD2DA-2 Analog Combination module offers the following features:

- The analog input and output channels are updated in one scan.
- The removable terminal block makes it possible to remove the module without disconnecting the field wiring.
- Analog inputs can be used as process variables for the four (4) PID loops in the DL05 CPU and the eight (8) PID loops in the DL06 CPUs.
- On-board active analog filtering and RISC-like microcontroller provide digital signal processing to maintain precise analog measurements in noisy environments.

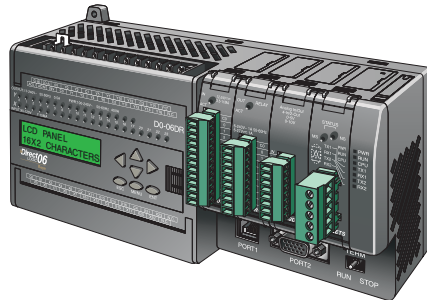

NOTE: The DL05 CPU's analog feature for this module requires **DirectSOFT32** Version 3.0c (or later) and firmware version 3.30 (or later). The DL06 requires **DirectSOFT32** version V4.0, build 16 (or later) and firmware version 1.00 (or later). See our website for more information: www.automationdirect.com.

The following tables provide the specifications for the F0-4AD2DA-2 Analog Combination Module. Review these specifications to make sure the module meets your application requirements.

Input Specifications	
Number of Channels	4, single ended (one common)
Input Range	0 to 5VDC or 0 to 10VDC (jumper selectable)
Resolution	12 bit (1 in 4096)
Step Response	10.0 ms to 95% of full step change
Crosstalk	-80dB, 1/2 count maximum*
Active Low-pass Filtering	-3dB at 300Hz (-12dB per octave)
Input Impedance	Greater than 20k Ω
Absolute Maximum Ratings	$\pm 15V$
Linearity Error (End to End)	± 2 counts maximum*
Input Stability	± 1 count*
Gain Error	± 6 counts maximum*
Offset Error	± 2 counts maximum*
Maximum Inaccuracy	$\pm 0.3\%$ @ 25°C (77°F)
	$\pm 0.6\%$ 0 to 60°C (32 to 140°F)
Accuracy vs. Temperature	± 100 ppm/°C typical

Output Specifications	
Number of Channels	2, single ended (one common)
Output Range	0 to 5 VDC or 0 to 10 VDC (jumper selectable)
Resolution	12 bit (1 in 4096)
Conversion Settling Time	50 μ S for full scale change
Crosstalk	-80db, 1/2 count maximum*
Peak Output Voltage	$\pm 15VDC$ (power supply limited)
Offset Error	0.1% of range
Gain Error	0.4% of range
Linearity Error (end to end)	± 1 count (0.075% of full scale) maximum*
Output Stability	± 2 counts*
Load Impedance	2k Ω maximum
Load Capacitance	0.01 μ F maximum
Accuracy vs. Temperature	± 50 ppm/°C typical

* One count in the specification table is equal to one least significant bit of the analog data value (1 in 4096).

General Specifications	
PLC Update Rate	4 input channels per scan 2 output channels per scan
16-bit Data Word	12 binary data bits
Operating Temperature	0 to 60° C (32 to 140° F)
Storage Temperature	-20 to 70° C (-4 to 158° F)
Relative Humidity	5 to 95% (non-condensing)
Environmental Air	No corrosive gases permitted
Vibration	MIL STD 810C 514.2
Shock	MIL STD 810C 516.2
Noise Immunity	NEMA ICS3-304
Power Budget Requirement	100mA @ 5VDC (supplied by base)
Connector	Phoenix Mecano, Inc. Part No. AK1550/8-3.5 - green
Connector Wire Size	28–16 AWG
Connector Screw Torque	3.5 inch-pounds (0.4 N-m)
Connector Screwdriver Size	DN-SS1 (recommended)

Setting the Module Jumpers

The position of the J2 jumpers determines the input and output signal levels. You can choose between 0–5 VDC or 0–10 VDC. The module ships with the jumpers installed connecting the pins. In this position, the input and output signal level is 0–5 VDC. To select 0–10 VDC signals, use the jumper selection chart located on the module. One or more channels can be selected for 0–10 VDC input and output signal level by removing the jumper from the connecting pin of the appropriate channel. This will allow you to have one channel selected for a 0–5 VDC signal and another channel selected for a 0–10 VDC signal.

J2, jumpers shown below, are configured as, CH1 and CH4 INPUTs and CH2 OUTPUT set for 10V. CH2 and CH3 INPUTs and CH1 OUTPUT set for 5V.

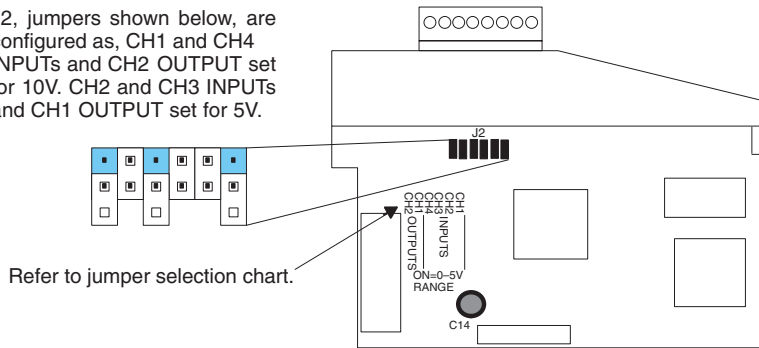

WARNING: Before removing the analog module or the terminal block on the face of the module, disconnect power to the PLC and all field devices. Failure to disconnect power can result in damage to the PLC and/or field devices.

Connecting and Disconnecting the Field Wiring

Wiring Guidelines

Your company may have guidelines for wiring and cable installation. If so, you should check those before you begin the installation. Here are some general things to consider:

- Use the shortest wiring route whenever possible.
- Use shielded wiring and ground the shield at the transmitter source. *Do not* ground the shield at both the module and the source.
- Do not run the signal wiring next to large motors, high current switches, or transformers. This may cause noise problems.
- Route the wiring through an approved cable housing to minimize the risk of accidental damage. Check local and national codes to choose the correct method for your application.

A separate transmitter power supply may be required, depending on the type of transmitter being used. This module has a removable connector to make wiring and module removal easier. To remove the terminal block, disconnect power to the PLC and the field devices. Pull the terminal block firmly until the connector separates from the module.

The analog module can be removed from the PLC by folding out the retaining tabs at the top and bottom of the module. As the retaining tabs pivot upward and outward, the module's connector is lifted out of the PLC socket. Once the connector is free, you can lift the module out of its slot.

Wiring Diagram

Use the following diagram to connect the field wiring. If necessary, the terminal block can be removed to make removal of the module possible without disturbing field wiring.

Typical User Wiring

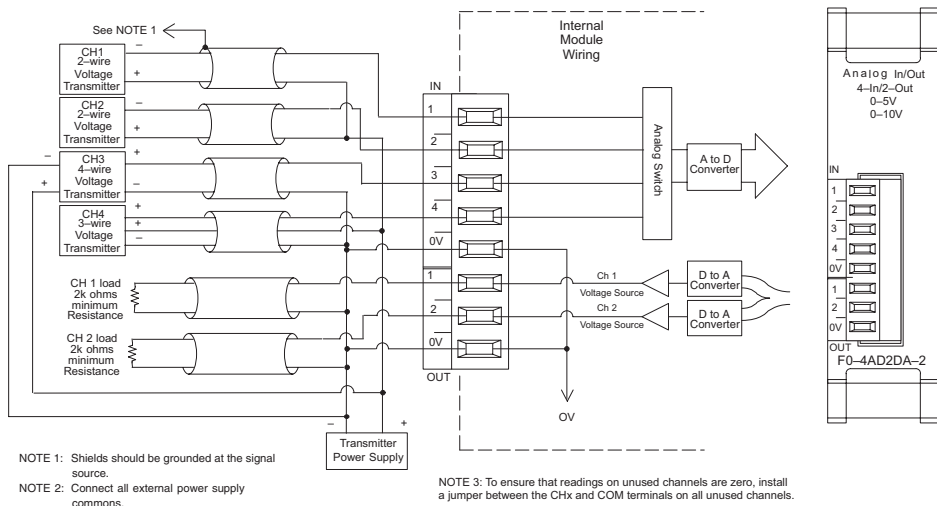

Module Operation

Input/Output Channel Update Sequence

The DL05 and DL06 read four channels of input data and two channels of output data during each scan. The CPU supports special V-memory locations that are used to manage the data transfer. This is discussed in more detail on the next page, “Special V-memory Locations”.

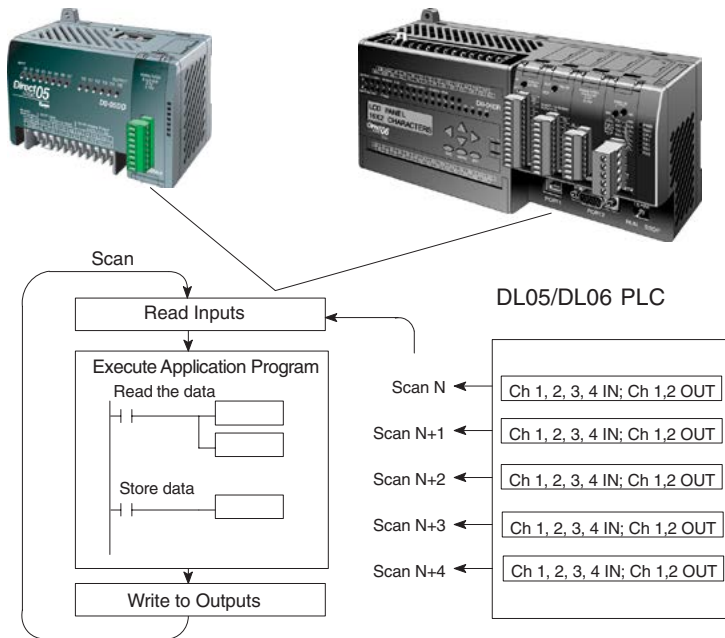

Analog Module Updates

Even though the channel updates to the CPU are synchronous with the CPU scan, the module asynchronously monitors the analog transmitter signals and converts each signal into a 12-bit binary representation. This enables the module to continuously provide accurate measurements without slowing down the discrete control logic in the RLL program.

The module takes approximately 10 milliseconds to sense 95% of the change in the analog signal. For the vast majority of applications, the process changes are much slower than these updates.



NOTE: If you are comparing other manufacturers' update times (step responses) with ours, please be aware that some manufacturers refer to the time it takes to convert the analog signal to a digital value. Our analog to digital conversion takes only a few microseconds. It is the settling time of the filter that is critical in determining the full update time. Our update time specification includes the filter settling time.

Special V-memory Locations

Formatting the Module Data

The DL05 and DL06 PLCs have three special V-memory locations assigned to their respective option slots. These V-memory locations allow you to:

- Specify the data format (binary or BCD)
- Specify the number of input and output channels to scan.
- Specify the V-memory locations to store the input data
- Specify the V-memory locations to store the output data

DL05 Data Formatting

The table below shows the special V-memory locations which are used by the DL05 PLC for the F0-4AD2DA-2.

Analog Combination Module DL05 Special V-memory Locations	
Data Type and Number of I/O Channels	V7700
Input Storage Pointer	V7701
Output Storage Pointer	V7702

Structure of V7700

V-memory location 7700 is used for identifying the number of output channels, the number of input channels and the data type (binary or BCD). The low byte equals the number of output channels and the high byte equals the number of input channels. Enter a 1 through 4 to select the number of input channels and a 1 through 2 to select the number of output channels to be used. A zero (0) entered for channel selection will cause the channel, either input or output, to be inoperative.

Loading a constant of 402 into V7700 identifies four input and two output analog channels, and sets the I/O data type to BCD.



Loading a constant of 8482 into V7700 identifies four input and two output analog channels, and sets the I/O data type to binary.

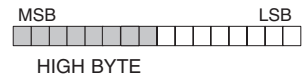

Structure of V7701

V7701 is a system parameter that points to a V-memory location used for storing analog input data. The V-memory location loaded in V7701 is an octal number identifying the first V-memory location for the analog input data. This V-memory location is user selectable. For example, loading O2000 using the LDA instruction causes the pointer to write Ch 1's data value to V2000, Ch 2's data value to V2001, CH 3's data value to V2002 and Ch 4's data value to V2003.

Structure of V7702

V7702 is a system parameter that points to a V-memory location used for storing analog output data. The V-memory location loaded in V7702 is an octal number identifying the first V-memory location for the analog output data. This V-memory location is user selectable. For example, loading O2010 using the LDA instruction causes the pointer to read Ch 1's data value at V2010 and Ch 2's data value at V2011.

You will find an example program that loads appropriate values to V7700, V7701 and V7702 on page 13-10.

DL06 Data Formatting

Special V-memory locations are assigned to the four option module slots of the DL06 PLC. The table below shows these V-memory locations which can be used for the F0-4AD2DA-2.

Analog Combination Module DL06 Special V-memory Locations				
Slot No.	1	2	3	4
Number of Channels	V700	V710	V720	V730
Input Pointer	V701	V711	V721	V731
Output Pointer	V702	V712	V722	V732

Setup Data Type and Number of Channels

V-memory location 700, 710, 720 and 730 are used for identifying the number of output channels, the number of input channels and the data type (binary or BCD). The low byte equals the number of output channels and the high byte equals the number of input channels. Enter a 1 through 4 to select the number of input channels and a 1 or 2 to select the number of output channels to be used. A zero (0) entered for channel selection will cause the channel, either input or output, to be inoperative.

For example, with a module installed in slot 4 by loading a constant of 402 into V730 identifies four input and two output analog channels, and sets the I/O data type to BCD.

Or, loading a constant of 8482 into V730 identifies four input and two output analog channels, and sets the I/O data type to binary.

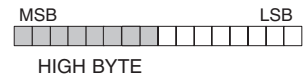

Input Storage Pointer Setup

V-memory locations 701, 711, 721 and 731 are special locations used as storage pointers for the analog input data. With the analog module installed in slot 4, the V-memory location loaded in V731, for instance, is an octal number identifying the first user V-memory location to read the analog input data. This V-memory location is user selectable. For example, loading O2000 using the LDA instruction causes the pointer to write Ch 1's data value to V2000, Ch 2's data value to V2001, CH 3's data value to V2002 and Ch 4's data value to V2003.

Output Storage Pointer Setup

V-memory locations 702, 712, 722 and 732 are special locations used as storage pointers for the analog output data. With the analog module installed in slot 4, the V-memory location loaded in V732 is an octal number identifying the first user V-memory location to write the analog output data to. This V-memory location is user selectable. For example, loading O2010 using the LDA instruction causes the pointer to read Ch 1's data value at V2010 and Ch 2's data value at V2011.

You will find an example program that loads appropriate values to V700, V701 and V702 on page 13-11.

Using the Pointer in Your Control Program

DL05 Pointer Method

The DL05 CPU examines the pointer values (the memory locations identified in V7700, V7701 and V7702) on the first scan only.

The example program below shows how to setup these locations for 4 input channels and 2 output channels. This rung can be placed anywhere in the ladder program or in the initial stage if you are using stage programming instructions.

This is all that is required to read the analog input data into V-memory locations. Once the data is in V-memory you can perform math on the data, compare the data against preset values, and so forth. V2000 and V2010 is used in the example but you can use any user V-memory location.

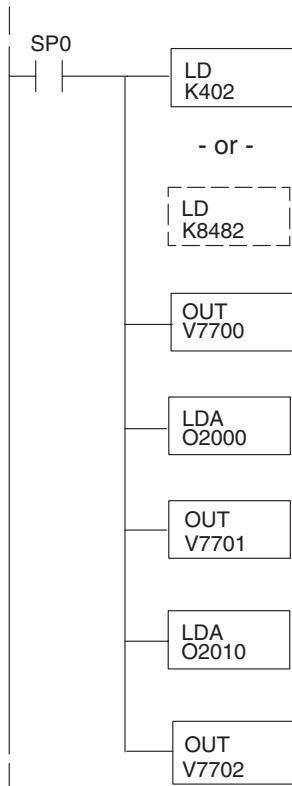

Loads a constant that specifies the number of channels to scan and the data format. The upper byte selects the input data format (i.e. 0=BCD, 8=Binary) and the number of input channels (set to 4). The lower byte selects the output data format (i.e. 0=BCD, 8=Binary) and the number of output channels (set to 2).

The binary format is used for displaying data on some operator interface units. The DL05 PLCs support binary math functions.

Special V-memory location assigned to the option slot contains the data format and the number of channels to scan.

This loads an octal value for the first V-memory location that will be used to store the incoming data. For example, the O2000 entered here would designate the following addresses:

Ch1 – V2000, Ch2 – V2001, Ch3 – V2002, Ch4 – V2003

The octal address (O2000) is stored here. V7701 is assigned to the option slot and acts as a pointer, which means the CPU will use the octal value in this location to determine exactly where to store the incoming data.

This loads an octal value for the first V-memory location that will be used to store the output data. For example, the O2010 entered here would designate the following addresses:

Ch1 – V2010, Ch2 – V2011

The octal address (O2010) is stored here. V7702 is assigned to the option slot and acts as a pointer, which means the CPU will use the octal value in this location to determine exactly where to get the output data.

DL06 Pointer Method

Use the special V-memory table as a guide to setup the pointer values in the following example for the DL06. Slot 1 is the left most option slot. The CPU will examine the pointer values at these locations only after a mode transition, first scan only.

Analog Combination Module DL06 Special V-memory Locations				
Slot No.	1	2	3	4
Number of Channels	V700	V710	V720	V730
Input Pointer	V701	V711	V721	V731
Output Pointer	V702	V712	V722	V732

The F0-4AD2DA-2 can be installed in any available DL06 option slot. Using the example program from the previous page, but changing the V-memory addresses, the ladder diagram below shows how to setup these locations for 4 input channels and 2 output channels with the module installed in slot1 of the DL06. Use the above table to determine the pointer values if locating the module in any of the other slot locations. Place this rung anywhere in the ladder program or in the initial stage if you are using stage programming instructions.

Like the DL05 example, this logic is all that is required to read the analog input data into V-memory locations. Once the data is in V-memory you can perform mathematical calculations with the data, compare the data against preset values, and so forth. V2000 and V2010 is used in the example but you can use any user V-memory location.

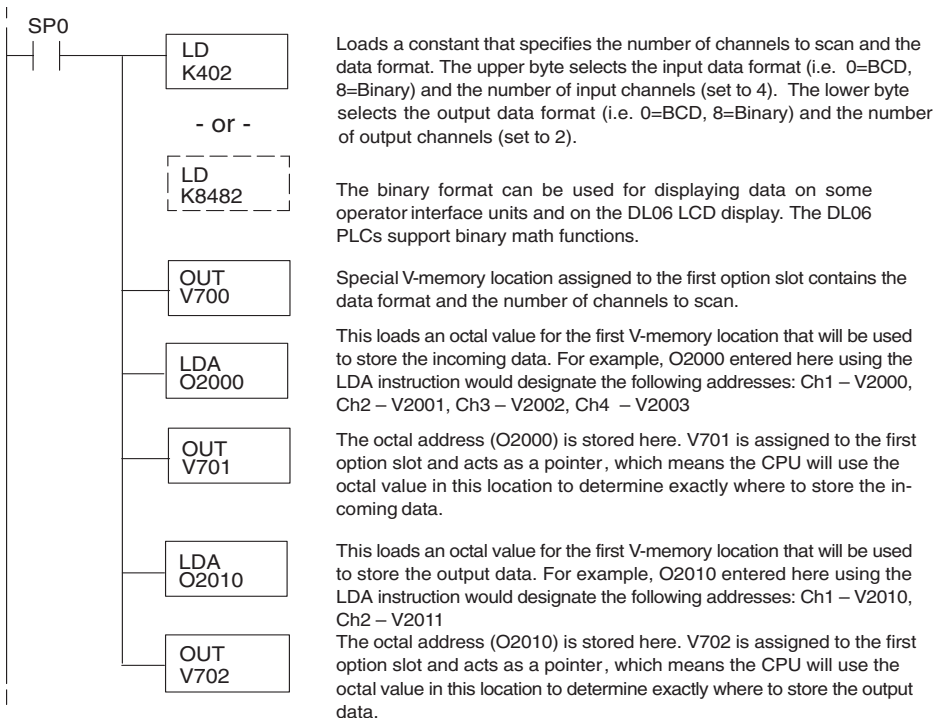

Scale Conversions

Scaling the Input Data

Many applications call for measurements in engineering units, which can be more meaningful than raw data. Convert to engineering units using the formula shown to the right.

You may have to make adjustments to the formula depending on the scale you choose for the engineering units.

$$\text{Units} = A \frac{H-L}{4095} + L$$

H = High limit of the engineering unit range

L = Low limit of the engineering unit range

A = Analog value (0 – 4095)

For example, if you wanted to measure pressure (PSI) from 0.0 to 100.0, then you would have to multiply the analog value by 10 in order to imply a decimal place when you view the value with the programming software or a handheld programmer. Notice how the calculations differ when you use the multiplier.

Analog Value of 2024, slightly less than half scale, should yield 49.4 PSI

Example without multiplier

$$\text{Units} = A \frac{H-L}{4095} + L$$

$$\text{Units} = 2024 \frac{100-0}{4095} + 0$$

$$\text{Units} = 49$$

Example with multiplier

$$\text{Units} = 10 A \frac{H-L}{4095} + L$$

$$\text{Units} = 20240 \frac{100-0}{4095} + 0$$

$$\text{Units} = 494$$

The Conversion Program

The following example shows how you would write the program to perform the engineering unit conversion from input data formats 0–4095. This example assumes the raw input data read at V2000 is in BCD format.

Note: this example uses SP1, which is always on. You could also use an X, C, etc. permissive contact.

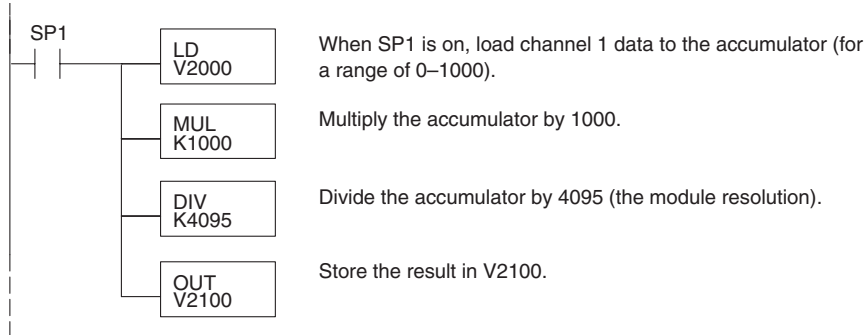

Output Conversion Program

The following example program shows how you would write the program to perform the engineering unit conversion to output data formats 0–4095. This example assumes you have calculated or loaded the engineering unit values between 0–1000 in BCD format and stored them in V2300 and V2301 for channels 1 and 2 respectively. The DL05 and DL06 offer instructions that allow you to perform math operations using BCD format. It is usually easier to perform any math calculations in BCD and then convert the value to binary before you send the data to the module.

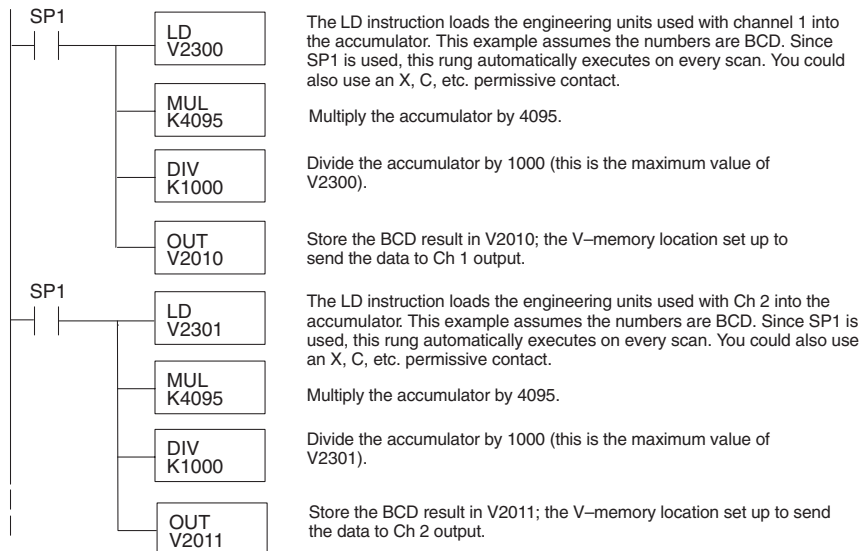

Analog and Digital Value Conversions

Sometimes it is useful to convert between the signal levels and the digital values. This is especially helpful during machine startup or troubleshooting. The following table provides formulas to make this conversion easier.

Range	If you know the digital value	If you know the analog signal level
0 to 5V	$A = \frac{5D}{4095}$	$D = \frac{4095}{5} (A)$
0 to 10V	$A = \frac{10D}{4095}$	$D = \frac{4095}{10} (A)$

For example, if you are using the 0–10V range and you need a 6V signal level, use this formula to determine the digital value (D) that will be stored in the V-memory location that contains the data.

$$D = \frac{4095}{10} (A)$$

$$D = \frac{4095}{10} (6V)$$

$$D = (409.5) (6) \qquad D = 2457$$

Module Resolution

Analog Data Bits

The first twelve bits represent the analog data for both inputs and outputs in binary format.

Bit	Value	Bit	Value
0	1	6	64
1	2	7	128
2	4	8	256
3	8	9	512
4	16	10	1024
5	32	11	2048

MSB												LSB											
[] [] [] [] [] [] [] [] [] [] [] []												[] [] [] [] [] [] [] [] [] [] [] []											
												1 1 9 8 7 6 5 4 3 2 1 0											
												1 0											

□ = data bits

Resolution Details

Since the module has 12-bit resolution for both inputs and outputs, the analog signal is either converted into 4096 counts or a count value will produce a proportional analog output. In either situation the count range will be from 0–4095 (2^{12}). For example, with an output range of 0 to 10V, send a 0 to get a 0V signal, and send 4095 to get a 10V signal. This is equivalent to a binary value of 0000 0000 0000 to 1111 1111 1111, or 000 to FFF hexadecimal.

Each count can also be expressed in terms of the signal level by using the following equation:

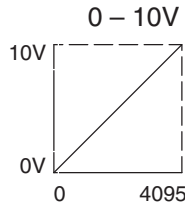

$$\text{Resolution} = \frac{H - L}{4095}$$

H = high limit of the signal range

L = low limit of the signal range

that will result in one LSB change in the data or the amount of change in the output signal that each increment of the count value will produce.

Voltage Range	Signal Span	Divide By	Smallest Detectable or Produced Change
0 to 5V	5 volts	4095	1.22 mV
0 to 10V	10 volts	4095	2.44 mV

Analog Input Ladder Logic Filter

PID Loops / Filtering

Please refer to the “PID Loop Operation” chapter in the DL06 or DL05 User Manual for information on the built-in PV filter (DL05/06) and the ladder logic filter (DL06 only) shown below. A filter must be used to smooth the analog input value when auto tuning PID loops to prevent giving a false indication of loop characteristics.

Smoothing the Input Signal (DL06 only)

The filter logic can also be used in the same way to smooth the analog input signal to help stabilize PID loop operation or to stabilize the analog input signal value for use with an operator interface display, etc.



WARNING: The built-in and logic filters are not intended to smooth or filter noise generated by improper field device wiring or grounding. Small amounts of electrical noise can cause the input signal to bounce considerably. Proper field device wiring and grounding must be done before attempting to use the filters to smooth the analog input signal.

Using Binary Data Format

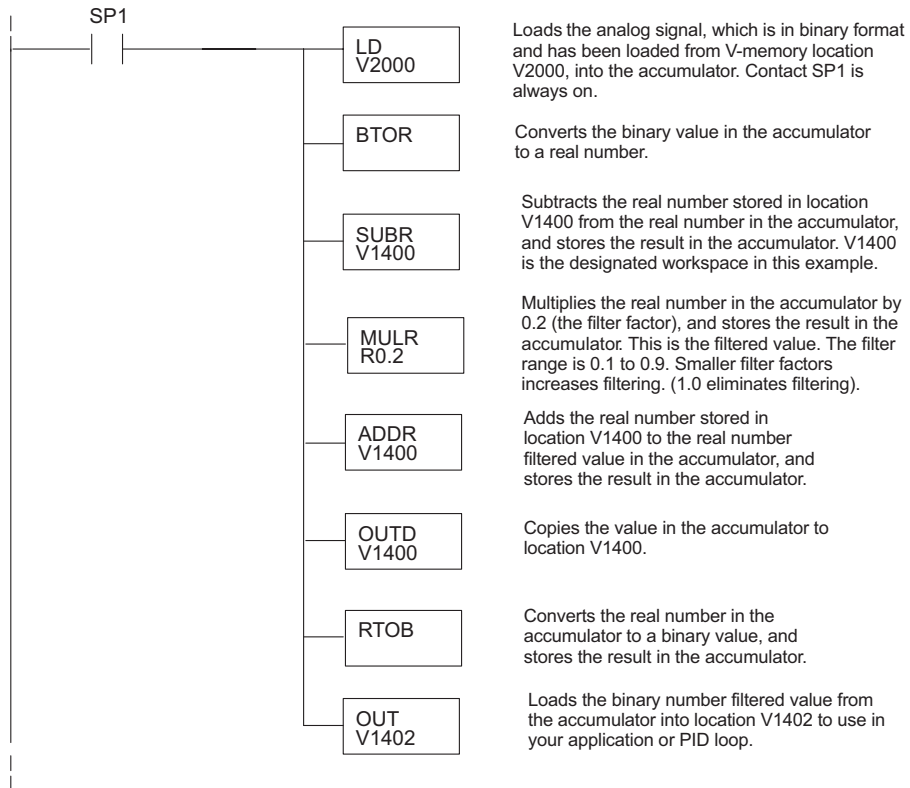



NOTE: Be careful not to do a multiple number conversion on a value. For example, if you are using the pointer method in BCD format to get the analog value, it must be converted to binary (BIN) as shown below. If you are using the pointer method in Binary format, the conversion to binary (BIN) instruction is not needed.

Using BCD Data Format

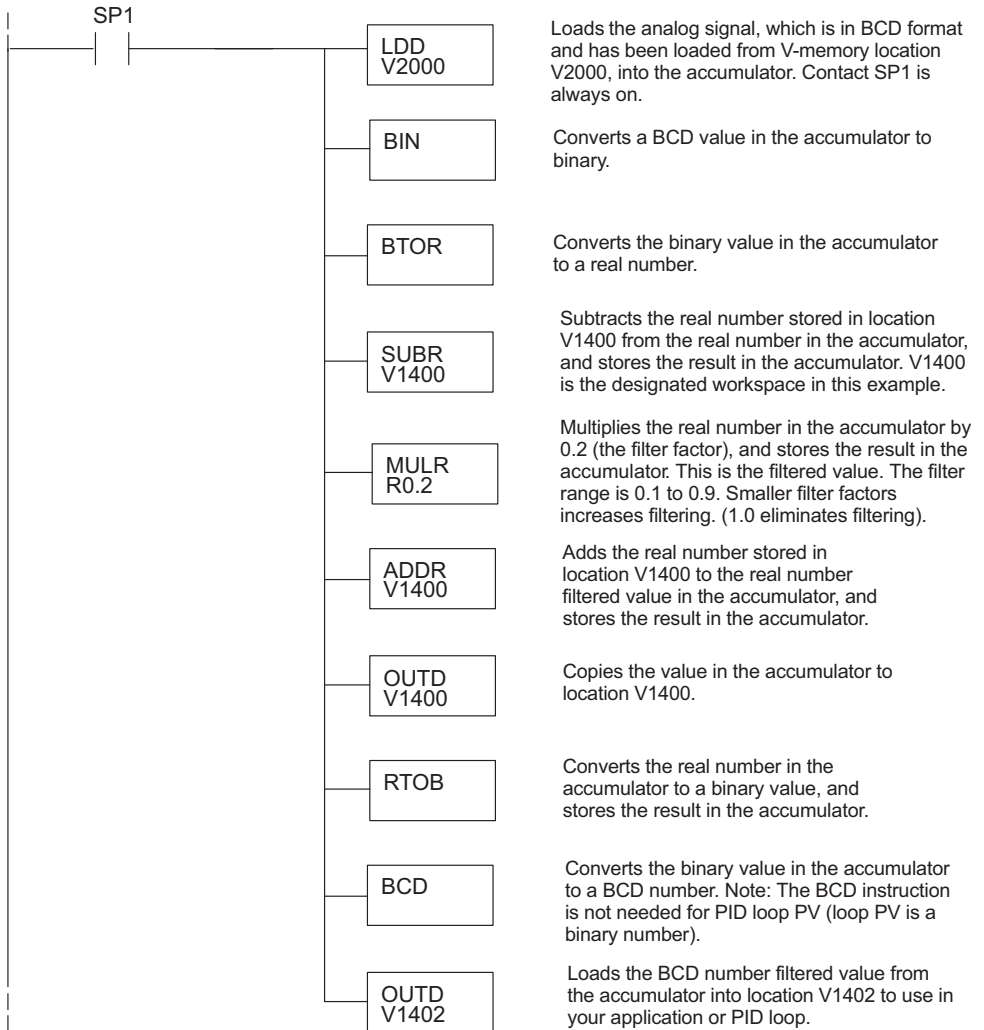

F0-04RTD, 4-CHANNEL RTD INPUT



In This Chapter...

Module Specifications	14-2
Connecting and Disconnecting the Field Wiring	14-4
Module Operation	14-6
Special V-memory Locations	14-7
Configuring the Module in Your Control Program	14-11
Negative Temperature Readings with Magnitude Plus Sign	14-15
Analog Input Ladder Logic Filter	14-18
RTD Burnout Detection Bits	14-20

Module Specifications

The F0-04RTD 4-Channel Resistive Temperature Detector Input Module provides the following features and benefits:

- Provides four RTD input channels with 0.1 °C/°F temperature resolution.
- Automatically converts type Pt100 Ω , jPt100 Ω , Pt1000 Ω , 10 Ω Cu, 25 Ω Cu, 120 Ω Ni RTD signals into direct temperature readings. No extra scaling or complex conversion is required.
- Temperature data can be expressed in °F or °C, and as magnitude plus sign or 2's complement.
- Precision lead wire resistance compensation by dual matched current sources and ratiometric measurements. Works with three wire and four wire RTDs.
- The temperature calculation and linearization are based on data provided by the National Institute of Standards and Technology (NIST).
- Diagnostic features include detection of short circuits and input disconnection.

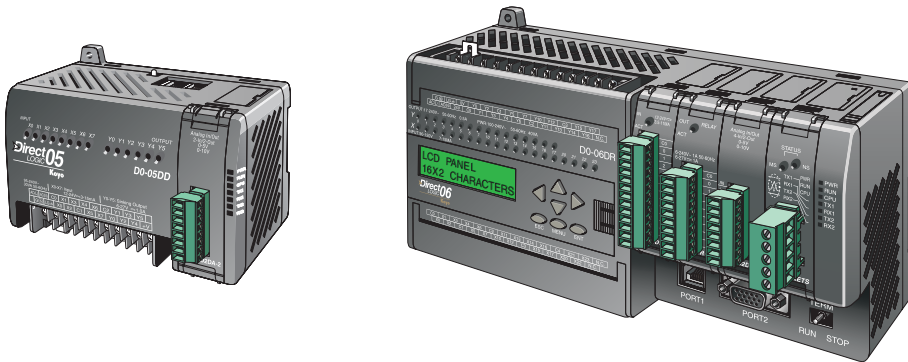

NOTE: The DL05 CPU's analog feature for this module requires **DirectSOFT32** Version 3.0c (or later) and firmware version 4.70 (or later). The DL06 requires **DirectSOFT32** version V4.0, build 16 (or later) and firmware version 1.50 (or later). See our website for more information: www.automationdirect.com.

Module Calibration

The module automatically re-calibrates every five seconds to remove any offset and gain errors. The F0-04RTD module requires no user calibration. However, if your process requires calibration, it is possible to correct the RTD tolerance using ladder logic. You can subtract or add a constant to the actual reading for that particular RTD. The actual reading can also be scaled to obtain the desired value using ladder logic.

Input Specifications

The following table provide the specifications for the F0-04RTD Input Module. Review these specifications to make sure the module meets your application requirements.

Input Specifications	
Number of Channels	4
Input Ranges	Pt100: -200.0 °C to 850.0 °C (-328°F to 1562°F) PT1000: -200.0 °C to 595.0 °C (-328°F to 1103°F) jPt100: -38.0 °C to 450.0 °C (-36°F to 842°F) 10Ω Cu: -200.0 °C to 260.0 °C (-328°F to 500°F) 25Ω Cu: -200.0 °C to 260.0 °C (-328°F to 500°F) 120Ω Ni: -80.0 °C to 260.0 °C (-112°F to 500°F)
Resolution	16 bit (1 in 65535)
Display Resolution	±0.1 °C, ±0.1 °F (±3276.7)
Absolute Maximum Ratings	Fault Protected Inputs to ±50VDC
Converter Type	Charge Balancing, 24 bit
Sampling Rate	140ms per channel
Linearity Error (End to End)	±0.05 °C maximum, ±0.01 °C typical
PLC Update Rate	4 channels/scan
Temperature Drift	15ppm / °C maximum
Maximum Inaccuracy	±1 °C
RTD Excitation Current	200μA
Common Mode Range	0–5 VDC
Notch Filter (Common Mode Rejection)	>50db notches at 50/60Hz
Digital Input Points Required	None; uses special V-memory locations based on slot
Power Budget Requirements	70mA @ 5VDC (supplied by base)
Operating Temperature	0 to 60° C (32 to 140° F)
Storage Temperature	-20 to 70° C (-4 to 158° F)
Relative Humidity	5 to 95% (non-condensing)
Environmental Air	No corrosive gases permitted
Vibration	MIL STD 810C 514.2
Shock	MIL STD 810C 516.2
Noise Immunity	NEMA ICS3-304
Replacement Terminal Block	D0-ACC-4
Wire Size Range & Connector Screw Torque	28–16 AWG; 3.5 inch-pounds (0.4 N·m); TW-SD-VSL-1 screwdriver recommended

Connecting and Disconnecting the Field Wiring

Wiring Guidelines

Your company may have guidelines for wiring and cable installation. If so, you should check those before you begin the installation. Here are some general things to consider:

- Use the shortest wiring route whenever possible.
- Use shielded wiring and ground the shield at the transmitter source. *Do not* ground the shield at both the module and the source.
- Unused channels require shorting wires (jumpers) installed from terminals CH+ to CH– to COM.
- Do not run the signal wiring next to large motors, high current switches, or transformers. This may cause noise problems.
- Route the wiring through an approved cable housing to minimize the risk of accidental damage. Check local and national codes to choose the correct method for your application.

To remove the terminal block, disconnect power to the PLC and the field devices. Pull the terminal block firmly until the connector separates from the module.

You can remove the RTD module from the PLC by folding out the retaining tabs at the top and bottom of the module. As the retaining tabs pivot upward and outward, the module's connector is lifted out of the PLC socket. Once the connector is free, you can lift the module out of its slot.

Use the following diagram to connect the field wiring. If necessary, the F0-04RTD terminal block can be removed to make removal of the module possible without disturbing field wiring.

RTD - Resistance Temperature Detector

Use shielded RTDs whenever possible to minimize noise on the input signal. Ground the shield wire at one end only, preferably at the RTD source.

Lead Configuration for RTD Sensors

The suggested three-lead configuration shown below provides one lead to the CH+ terminal, one lead to the CH– terminal, and one lead to the common terminal. Compensation circuitry nulls out the lead length for accurate temperature measurements.

Some sensors have four leads. When making connections, do not connect the second lead to the CH+ input; leave that lead unconnected.

Do not use configurations that lack the use of the same color lead to both the CH– and COM terminals. There is no compensation and temperature readings will be inaccurate.

This module has low RTD excitation current, worst-case dissipation with 100Ω RTDs connected is only 0.016mW.

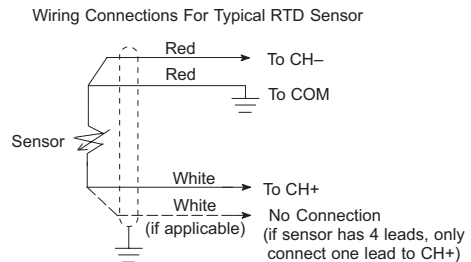

Ambient Variations in Temperature

The F0-04RTD module has been designed to operate within the ambient temperature range of 0°C to 60°C.

Precision analog measurement with no long term temperature drift is assured by a chopper stabilized programmable gain amplifier, ratiometric referencing, and automatic offset and gain calibration.

Wiring Diagram

Use the following diagram to connect the field wiring. If necessary, the F0-04RTD terminal block can be removed to make removal of the module possible without disturbing field wiring.

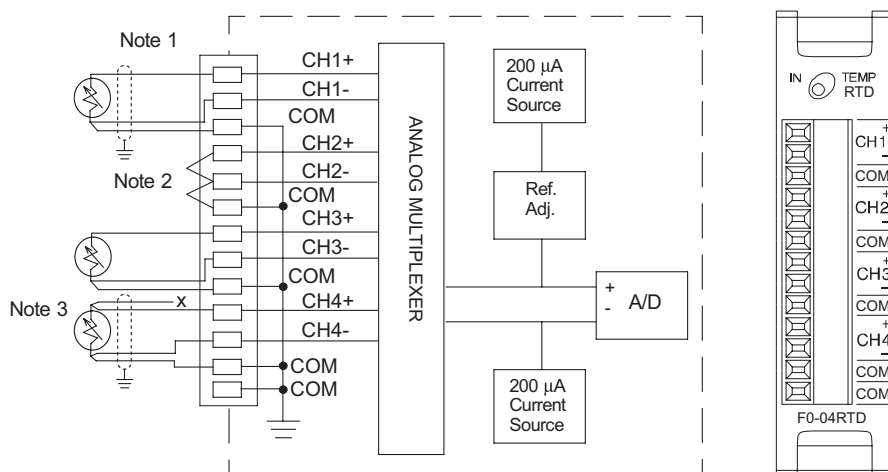

Notes:

1. The three wires connecting the RTD to the module must be the same type and length. Do not use the shield or drain wire for the third connection.
2. Unused channels require shorting wires (jumpers) installed from terminals CH+ to CH- to COM to prevent possible noise from influencing active channels. This should be done even if the unused channel is not enabled in the V-memory configuration.
3. If a RTD sensor has four wires, the plus sense wire should be left unconnected as shown.

Module Operation

Channel Scanning Sequence

The DL05 and DL06 read all four input channels data during each scan. The CPUs support special V-memory locations that are used to manage the data transfer. This is discussed in more detail on the following page, “Special V-memory Locations”.

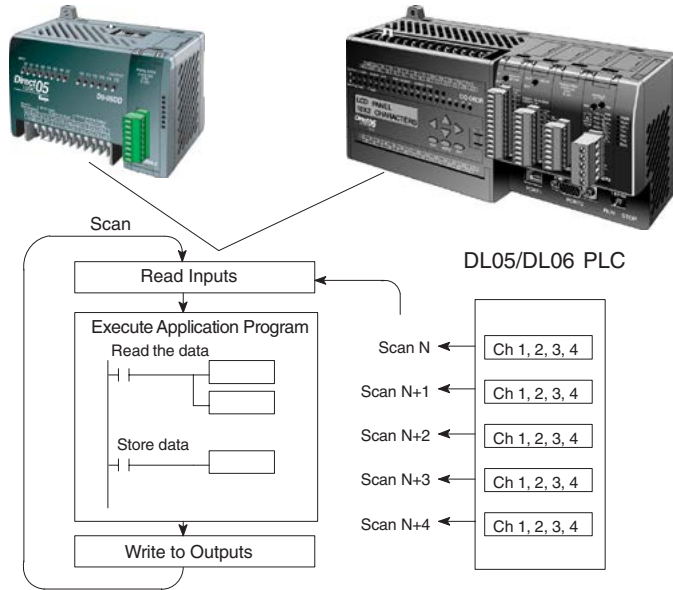

Analog Module Update

Even though the channel updates to the CPU are synchronous with the CPU scan, the module asynchronously monitors the analog transmitter signal and converts the signal to a 16-bit binary representation. This enables the module to continuously provide accurate measurements without slowing down the discrete control logic in the RLL program.

The time required to sense the temperature and copy the value to V-memory is 140 milliseconds minimum to 560 milliseconds plus 1 scan time maximum (number of channels x 140 milliseconds + 1 scan time).

Special V-memory Locations

The DL05 and DL06 PLCs have special V-memory locations assigned to their respective option slots. These V-memory locations allow you to:

- Specify the number of input channels enabled and BCD/Binary data format
- Specify the input pointer address
- Specify the RTD input type
- Specify the units code – temperature scale and data format
- Specify burnout data value at burnout
- Read module setup diagnostics

Module Configuration Registers

Module Configuration Parameters	DL05 and DL06 Option Slot				
	DL05 Slot	DL06 Slot 1	DL06 Slot 2	DL06 Slot 3	DL06 Slot 4
A: Number of Channels Enabled / Data Format	V7700	V700	V710	V720	V730
B: Input Pointer	V7701	V701	V711	V721	V731
C: RTD Type	V7703	V703	V713	V723	V733
D: Units Code	V7704	V704	V714	V724	V734
E: RTD Burnout Data Value	V7706	V706	V716	V726	V736
F: Diagnostic Error	V7707	V707	V717	V727	V737

The table below shows the special V-memory locations used by the DL05 and DL06 PLCs for the F0-04RTD module.

A: Number of Channels Enabled/Data Format Register

Number of Channels Enabled	Channel Data in BCD Format	Channel Data in Binary Format
1 Channel	K100	K8100
2 Channels	K200	K8200
3 Channels	K300	K8300
4 Channels	K400	K8400

This V-memory location is used to define the number of input channels to be enabled and to set the channel data to BCD or binary format.

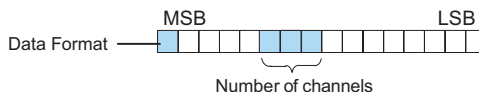

B: Input Pointer Register

This is a system parameter that points to a V-memory location used for storing module channel input data. The V-memory location loaded in the input pointer V-memory location is an octal number identifying the first V-memory location for the input data. This V-memory location is user defined, but must use available consecutive V-memory locations. For example, loading O2000 causes the pointer to write Ch 1's data value to V2000/2001, Ch 2's data value to V2002/2003, CH 3's data value to V2004/2005 and Ch 4's data value to V2006/2007.



NOTE: Each channel's data value occupies two (2) consecutive V-memory locations. This allows for more than four (4) digits to be displayed if a BCD format for channel data is selected. For example: 1234.5 °F. A binary format for either a 15-bit magnitude plus sign or 16-bit 2's complement value will occupy the first V-memory location of the two V-memory locations assigned for the selected channel. Refer to the specific PLC's user manual being used for available user V-memory locations.

C: RTD Type Selection Register

The F0-04RTD module supports six different RTD types. The type must be specified by placing a value from the table shown below into a V-memory register. The register is determined by the PLC type and slot number, as listed in the Module Configuration Registers table on the previous page. For example, if using a Pt1000 RTD with a module installed in slot 2 of a DL06, load a value of 4 into V713. All channels of the module must be the same RTD type.

RTD Type	Input Selection
Pt100 (European curve w/TCR = 0.00385)	K0
Cu10	K1
Cu25	K2
jPt100 (American curve w/TCR = 0.00392)	K3
Pt1000	K4
Ni120	K5

The factory default setting is for Pt100Ω RTDs. This selects the DIN 43760 European platinum type RTD. European curve type RTDs are calibrated to DIN 43760, BS1905, or IEC751 specifications which is 0.00385 Ω/Ω/°C (100 °C = 138.5 Ω).

The jPt100 type for the American curve 100Ω platinum RTD is more commonly used in North America.

The Cu10 (10Ω) and Cu25 (25Ω) RTD settings are used with copper RTDs.

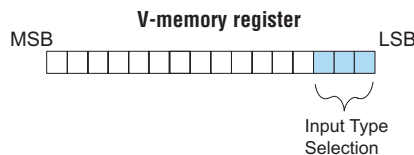

D: Units Code Register

All RTD types are converted into a direct temperature reading in either Fahrenheit or Celsius. The data contains one implied decimal place. For example, a value in V-memory of 1002 would be 100.2 °C or °F.

All RTD ranges can include negative temperatures, therefore the display resolution is from -3276.7 to +3276.7.

Negative temperatures can be represented in either 2's complement or magnitude plus sign form. If the temperature is negative, the most significant bit in the V-memory location is set.

The 2's complement data format may be required to correctly display bipolar data on some operator interfaces. This data format could also be used to simplify averaging a bipolar signal. To view this data format in *DirectSoft32*, select Signed Decimal.

The bipolar input ranges may be converted to a 15-bit magnitude plus sign or a 16-bit 2's complement value.

Bit 0 = Temperature Scale
 0 = Temp in degrees F
 1 = Temp in degrees C

Bit 1 = Data Format
 0 = Magnitude plus sign bit format
 1 = 2's Complement format

Unit Code Register - Truth Table				
Temperature Scale	Data Format	Bit 1	Bit 0	Value
°F	Magnitude + sign bit	0	0	K0
°C	Magnitude + sign bit	0	1	K1
°F	2's Complement	1	0	K2
°C	2's Complement	1	1	K3

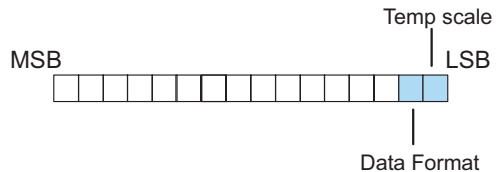

E: RTD Burnout Data Value Register

This register is used to define either up scale or down scale channel values when a channel RTD burnout occurs.

Bit 0 = Up scale/down scale value at Burnout

0 = Up scale value at Burnout, 7FFFh (BCD/HEX) or 32767 (Binary)
written to CH register

1 = Down scale value at Burnout: 0000h (BCD/HEX) or 0 (Binary)
written to CH register

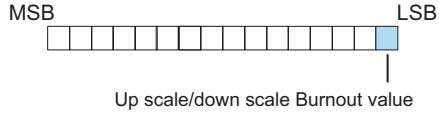

0 = Module setup is valid

1 = Module setup is not valid

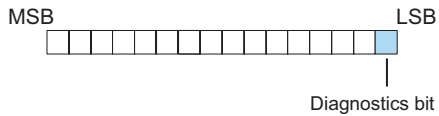

Configuring the Module in Your Control Program

DL05 Example 1

The example program below shows how to setup the F0-04RTD for 4 input channels enabled, use of a type Pt100 RTD on all 4 input channels, BCD channel data format, the Fahrenheit (°F) temperature scale, magnitude plus sign bit format, and an up scale burnout value specified. Place this rung anywhere in the ladder program or in the initial stage if you are using stage programming instructions.

This is all that is required to read the temperature or voltage input data into V-memory locations. Once the data is in V-memory you can perform mathematical calculations with the data, compare the data against preset values, etc. V2000 is used in the example but you can use any user V-memory location.

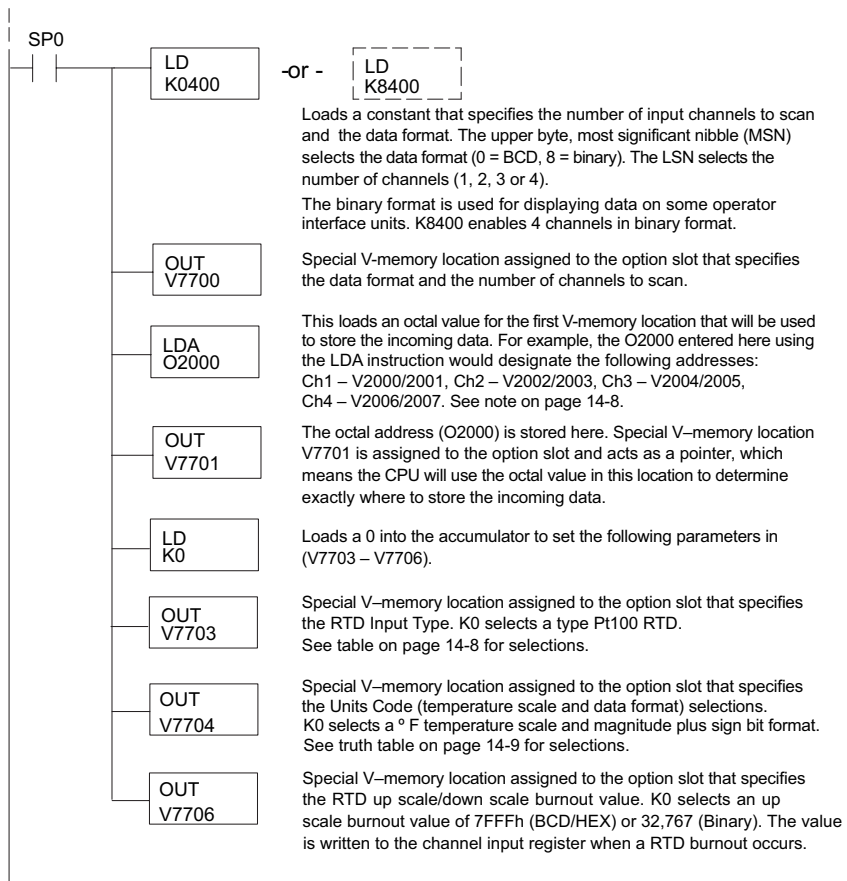

DL05 Example 2

The example program below shows how to setup the F0-04RTD for 2 input channels enabled, use of a type Cu10 RTD on the first 2 input channels, BCD channel data format, Celsius (°C) temperature scale, 2's complement format, and with a down-scale burnout value specified. Again, place this rung in the ladder program or in the initial stage if you are using stage programming instructions.

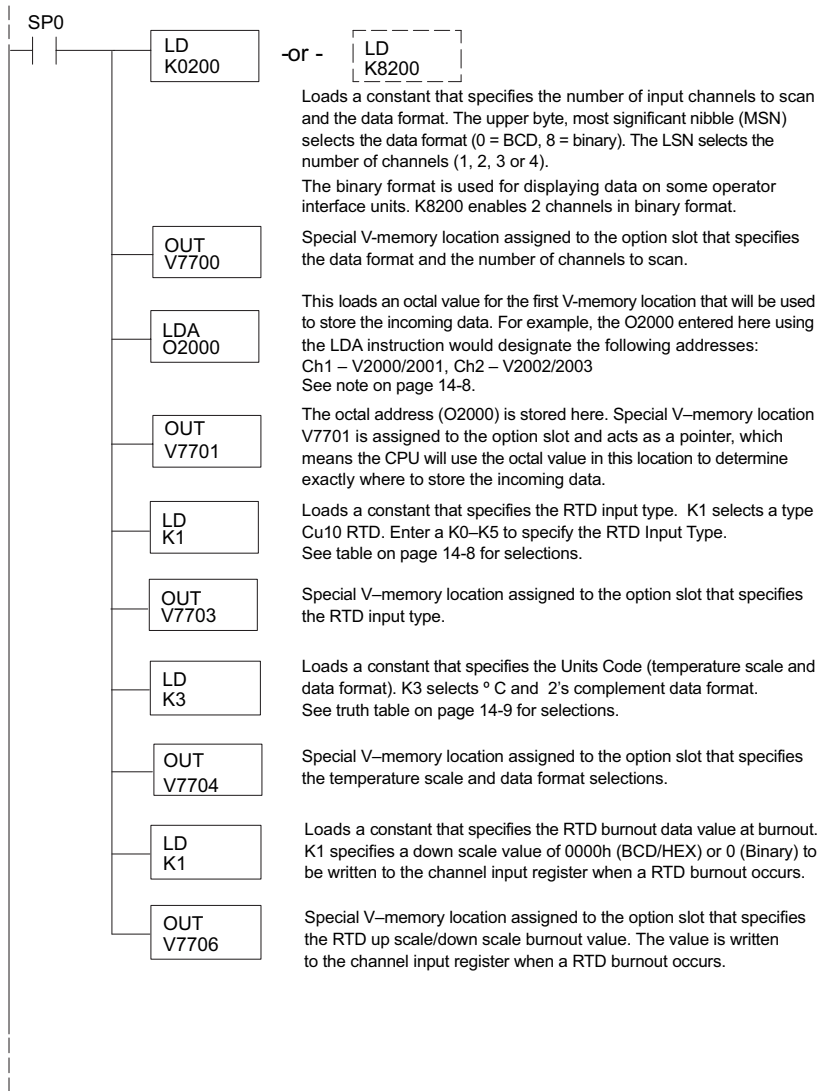

DL06 Example 1

The example program below shows how to setup the F0-04RTD in option slot 1 for 4 input channels enabled, use of a type Pt100 RTD on all 4 input channels, BCD channel data format, Fahrenheit (°F) temperature scale, magnitude plus sign bit format, and an up-scale burnout value specified. Use the table shown on page 14-7 to determine the pointer values if locating the module in any of the other slots. Place this rung anywhere in the ladder program or in the initial stage if you are using stage programming instructions.

This is all that is required to read the temperature or voltage input data into V-memory locations. Once the data is in V-memory you can perform mathematical calculations with the data, compare the data against preset values, etc. V2000 is used in the example but you can use any user V-memory location.

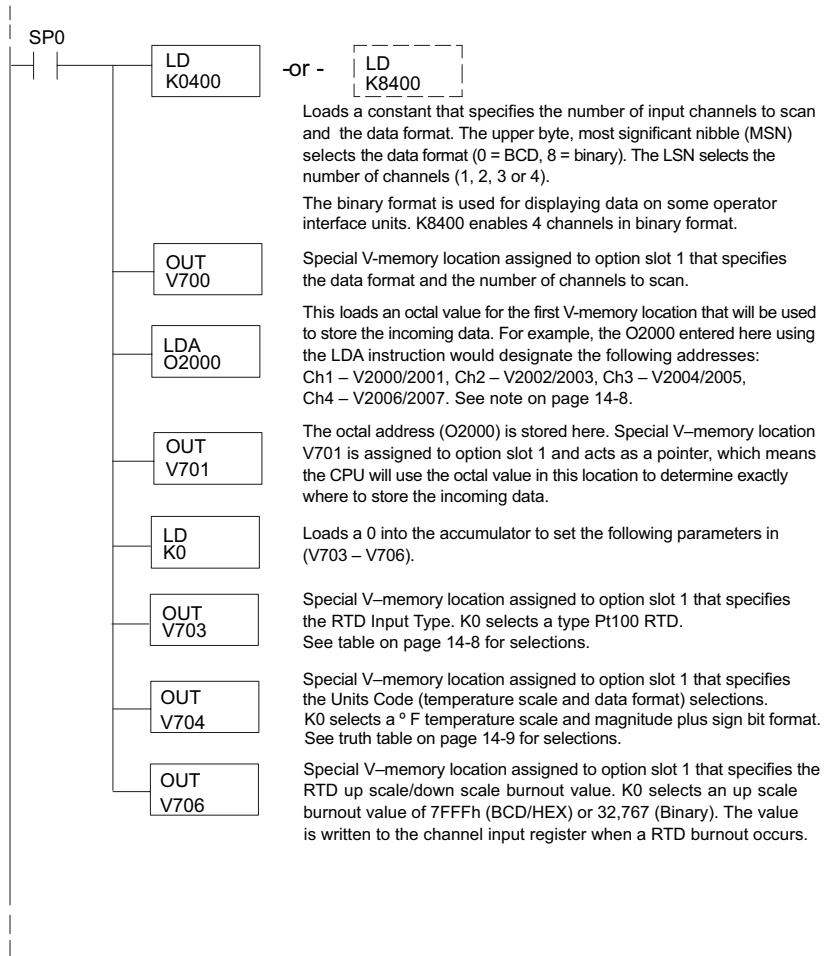

DL06 Example 2

The example program below shows how to setup the F0-04RTD in option slot 2 for 2 input channels enabled, use of a type Cu10 RTD on the first 2 input channels, BCD channel data format, Celsius (°C) temperature scale, 2's complement format, and with a down scale burnout value specified. Use the table shown on page 14-7 to determine the pointer values if locating the module in any of the other slots. V-memory location V3000 is shown in the example, but you can use any available user V-memory location. Again, place this rung anywhere in the ladder program or in the initial stage if you are using stage programming instructions.

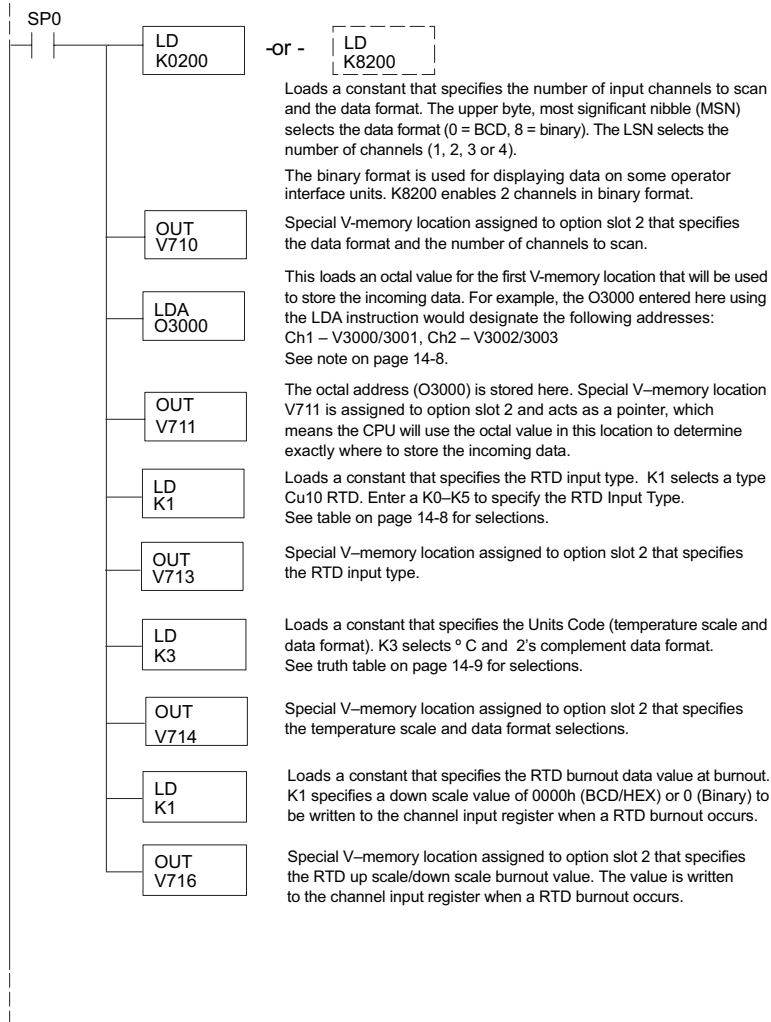

Negative Temperature Readings with Magnitude Plus Sign

With bipolar ranges, you need some additional logic to determine whether the value being returned represents a positive temperature or a negative temperature. There is a simple solution:

- If you are using bipolar ranges and you get a value greater than or equal to 8000h, the value is negative.
- If you get a value less than or equal to 7FFFh, the value is positive.

The sign bit is the most significant bit, which combines 8000h to the data value. If the value is greater than or equal to 8000h, you only have to mask the most significant bit and the active channel bits to determine the actual data value.

The following two programs show how you can accomplish this. The first example uses magnitude plus sign (binary) and the second example uses magnitude plus sign (BCD).

Since you always want to know when a value is negative, these rungs should be placed before any other operations that use the data, such as math instructions, scaling operations, and so forth. Also, if you are using stage programming instructions, these rungs should be in a stage that is always active. **Note: you only need this logic for each channel that is using bipolar input signals. The examples only show two channels.**

Magnitude Plus Sign (Binary)

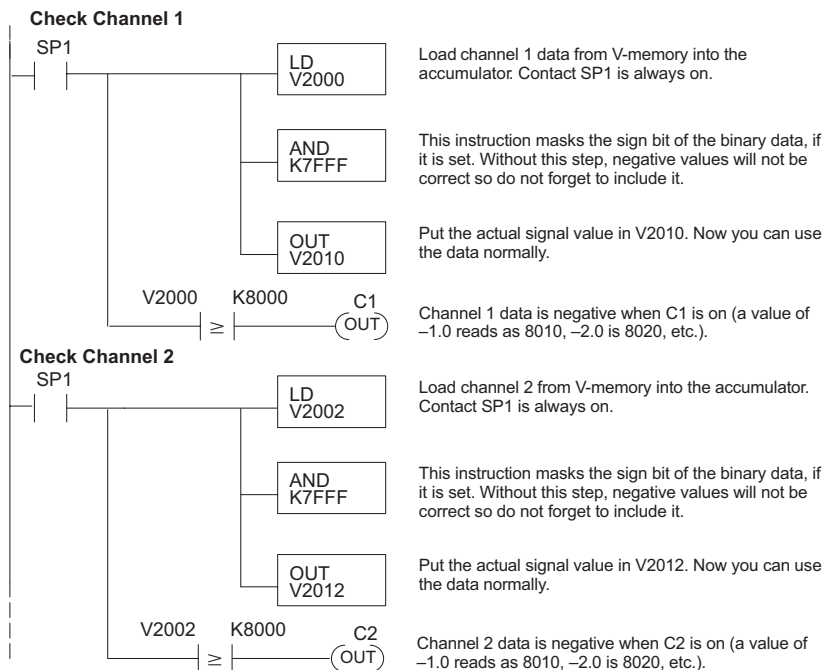

Magnitude Plus Sign (BCD)

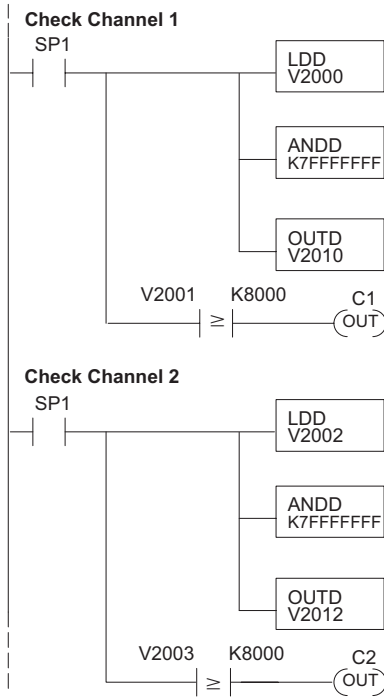

Load channel 1 data from V-memory into the accumulator. Remember, the data can be negative. Contact SP1 is always on.

This instruction masks the sign bit of the BCD data, if it is set. Without this step, negative values will not be correct so do not forget to include it.

Put the actual signal value in V2010. Now you can use the data normally.

Channel 1 data is negative when C1 is on (a value of -1.0 reads as 8000 0010, -2.0 is 8000 0020, etc.).

Load channel 2 from V-memory into the accumulator. Remember, the data can be negative. Contact SP1 is always on.

This instruction masks the sign bit of the BCD data, if it is set. Without this step, negative values will not be correct so do not forget to include it.

Put the actual signal value in V2012. Now you can use the data normally.

Channel 2 data is negative when C2 is on (a value of -1.0 reads as 8000 0010, -2.0 is 8000 0020, etc.).

Negative Temperatures 2's Complement (Binary/Pointer Method)

You can use the 2's complement mode for negative temperature display purposes, while at the same time using the magnitude plus sign of the temperature in your control program. The *DirectSOFT*32 element Signed Decimal is used to display negative numbers in 2's complement form. To find the absolute value of a negative number in 2's complement, invert the number and add 1 as shown in the following example:

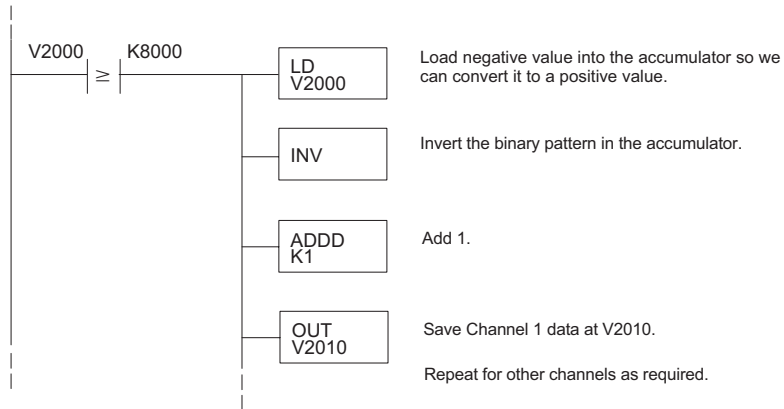

Analog Input Ladder Logic Filter

PID Loops / Filtering

Please refer to the “PID Loop Operation” chapter in the DL06 or DL05 User Manual for information on the built-in PV filter (DL05/06) and the ladder logic filter (DL06 only) shown below. A filter must be used to smooth the analog input value when auto tuning PID loops to prevent giving a false indication of loop characteristics.

Smoothing the Input Signal (DL06 only)

The filter logic can also be used in the same way to smooth the analog input signal to help stabilize PID loop operation or to stabilize the analog input signal value for use with an operator interface display, etc.



WARNING: The built-in and logic filters are not intended to smooth or filter noise generated by improper field device wiring or grounding. Small amounts of electrical noise can cause the input signal to bounce considerably. Proper field device wiring and grounding must be done before attempting to use the filters to smooth the analog input signal.

Using Binary Data Format

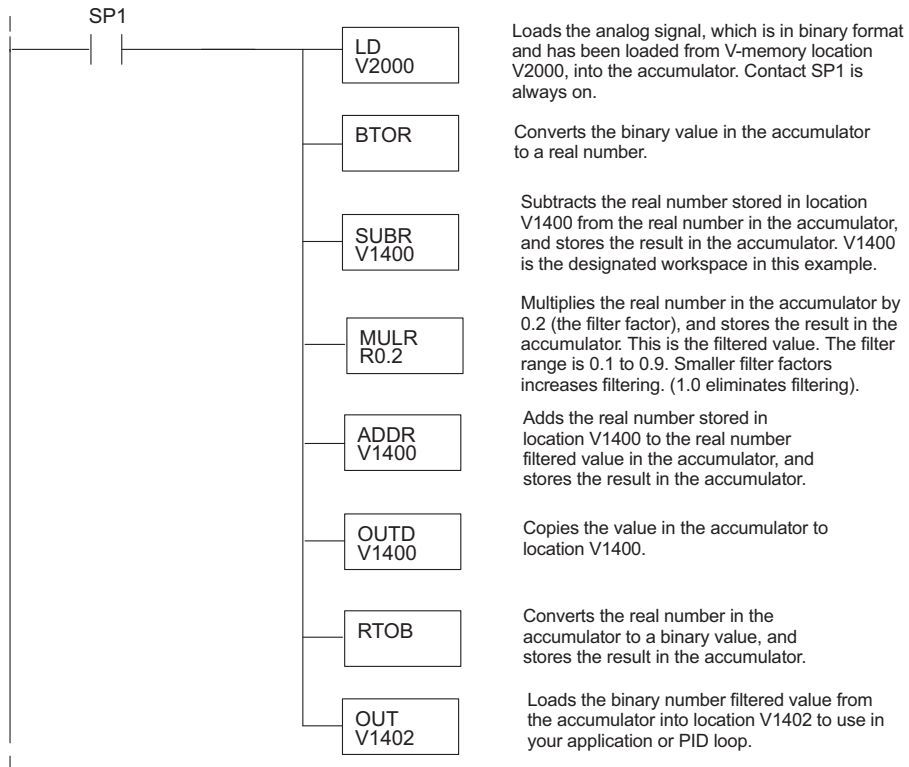



NOTE: Be careful not to do a multiple number conversion on a value. For example, if you are using the pointer method in BCD format to get the analog value, it must be converted to binary (BIN) as shown below. If you are using the pointer method in Binary format, the conversion to binary (BIN) instruction is not needed.

Using BCD Data Format

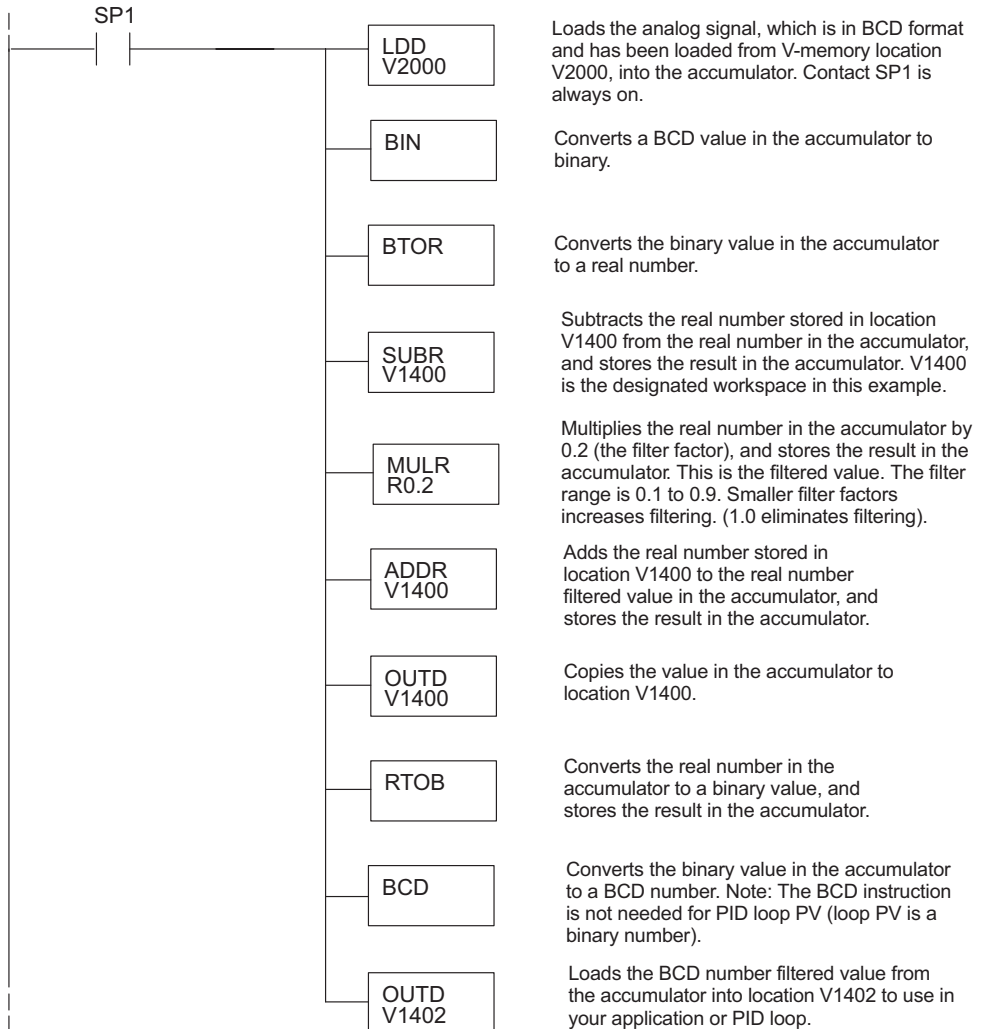

RTD Burnout Detection Bits

Special Relays Corresponding to RTD Burnouts

The following Special Relay (SP) bits can be used in your program to monitor for RTD burnout.

SP bit :

0 = RTD OK

1 = RTD burnout

Module Channel	DL05 and DL06 Option Slot				
	DL05 Slot	DL06 Slot 1	DL06 Slot 2	DL06 Slot 3	DL06 Slot 4
Channel 1	SP600	SP140	SP240	SP340	SP440
Channel 2	SP601	SP141	SP241	SP341	SP441
Channel 3	SP602	SP142	SP242	SP342	SP442
Channel 4	SP603	SP143	SP243	SP343	SP443

FO-04THM 4-CHANNEL THERMOCOUPLE INPUT



In This Chapter...

Module Specifications	15-2
Connecting and Disconnecting the Field Wiring	15-4
Module Operation	15-7
Special V-memory Locations	15-8
Configuring the Module in Your Control Program	15-12
Negative Temperature Readings with Magnitude Plus Sign	15-16
Module Resolution.....	15-18
Analog Input Ladder Logic Filter	15-19
Thermocouple Burnout Detection Bits	15-21

Module Specifications

The F0-04THM 4-Channel Thermocouple Input Module provides the following features and benefits:

- Four thermocouple input channels with 16-bit voltage resolution or 0.1 °C/°F temperature resolution.
- Automatically converts type E, J, K, R, S, T, B, N, or C thermocouple signals into direct temperature readings. No extra scaling or complex conversion is required.
- Temperature data can be expressed in °F or °C.
- Module can be configured as 0–39.0625 mVDC, ±39.0625 mVDC, ±78.125 mVDC, 0–156.25 mV, ±156.25 mVDC and 0–1.25 VDC input and will convert volts and millivolt signal levels into 16-bit digital (0–65535) values.
- Signal processing features include automatic cold junction compensation (CJC), thermocouple linearization, and digital filtering.
- The temperature calculation and linearization are based on data provided by the National Institute of Standards and Technology (NIST).
- Diagnostic features include detection of thermocouple burnout or disconnection.

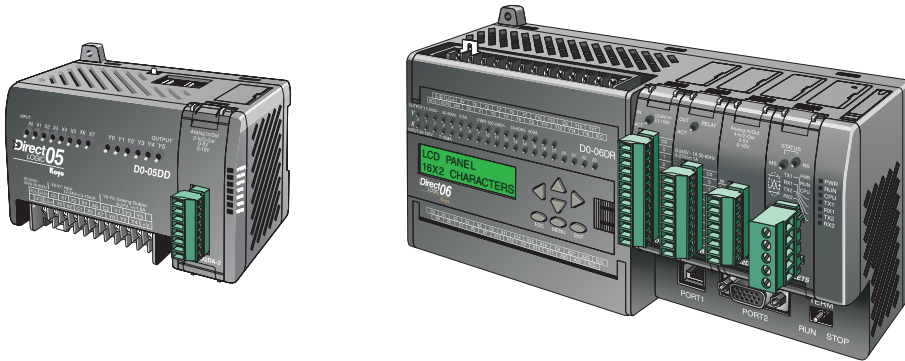

NOTE: The DL05 CPU's analog feature for this module requires **DirectSOFT32** Version 3.0c (or later) and firmware version 4.60 (or later). The DL06 requires **DirectSOFT32** version V4.0, build 16 (or later) and firmware version 1.40 (or later). See our website for more information: www.automationdirect.com.

The following tables provide the specifications for the F0-04THM Analog Input Module. Review these specifications to make sure the module meets your application requirements.

General Specifications	
Number of Channels	4, differential inputs, voltage or thermocouple
Common Mode Range	-1.3 VDC to +3.8 VDC
Conversion Time	270ms / channel
Common Mode Rejection	> 100dB @ 50/60Hz.
Input Impedance	5MΩ min.
Absolute Maximum Ratings	Fault-protected inputs to ±50VDC
Accuracy vs. Temperature	±15ppm / °C maximum (Full scale);
Max. full scale error (including offset)	±35ppm / °C maximum (0–1.25 V)
PLC Update Rate	4 channels per scan
Power Budget Requirement	30mA @ 5VDC (supplied by base)
Operating Temperature	0 to 60°C (32 to 140°F)
Storage Temperature	-20 to 70°C (-4 to 158°F)
Relative Humidity	5 to 95% (non-condensing)
Environmental Air	No corrosive gases permitted
Vibration	MIL STD 810C 514.2
Shock	MIL STD 810C 516.2
Noise Immunity	NEMA ICS3-304
Replacement Terminal Block	F0-IOCON-THM (comes with CJC)
Wire Size Range & Connector Screw Torque	22–16 AWG; 1.7 inch-pounds (0.192 N-m); TW-SD-VSL-1 Screwdriver Recommended

Thermocouple Specifications	
Input Ranges	Type J -190 to 760 °C (-310 to 1400 °F) Type K -150 to 1372 °C (-238 to 2502 °F) Type E -210 to 1000 °C (-346 to 1832 °F) Type R 65 to 1768 °C (149 to 3214 °F) Type S 65 to 1768 °C (149 to 3214 °F) Type T -230 to 400 °C (-382 to 752 °F) Type B 529 to 1820 °C (984 to 3308 °F) Type N -70 to 1300 °C (-94 to 2372 °F) Type C 65 to 2320 °C (149 to 4208 °F)
Display Resolution	±0.1 °C or ±0.1 °F
Cold Junction Compensation	Automatic
Warm-Up Time	30 minutes typically ± 1°C repeatability
Linearity Error (End to End)	±1°C maximum, ±0.5 °C typical
Maximum Inaccuracy	±3°C (excluding thermocouple error)

Voltage Input Specifications	
Voltage Ranges	0-39.0625 mVDC, ±39.0625 mVDC, ±78.125 mVDC, 0-156.25 mVDC, ±156.25 mVDC, 0-1.25 VDC
Resolution	16 bit (1 in 65535)
Max. Offset Error (All Input Ranges)	0.05% @ 0-60 °C; Typical: 0.04% @ 25 °C
Linearity Error (All Input Ranges)	0.05% @ 0-60 °C; Typical: 0.03% @ 25 °C
Maximum Inaccuracy	0-39.0625 mVDC, ±39.0625 mVDC, ±78.125 mVDC ranges: 0.1% @ 0-60°C; Typical: 0.04% @ 25°C 0-156.25 mVDC, ±156.25 mVDC, 0-1.25 VDC ranges: 0.05% @ 0-60°C; Typical: 0.04% @ 25°C
All percentages are calculated as a percent of 2 ¹⁶ (65536) counts. (0.025% max error => 0.025 * 65536/100 = 16 counts max error)	

Thermocouples

Use shielded thermocouples whenever possible to minimize the presence of noise on the thermocouple wire. Ground the shield wire at one end only. For both grounded and ungrounded thermocouples, connect the shield to the 0V (common) terminal of the PLC power supply.

Grounded Thermocouple Assembly

A grounded thermocouple provides better response time than an ungrounded thermocouple because the tip of the thermocouple junction is in direct contact with the protective case.

Ungrounded Thermocouple Assembly

An ungrounded thermocouple is electrically isolated from the protective case. If the case is electrically grounded it provides a low-impedance path for electrical noise to travel. The ungrounded thermocouple provides a more stable and accurate measurement in a noisy environment. To avoid exceeding the common mode specifications, be sure that the machine assembly is properly bonded together.

Exposed Grounded Thermocouple

The thermocouple does not have a protective case and is directly connected to a device with a higher potential. Grounding the thermocouple assures that the thermocouple remains within the common mode specifications. Because a thermocouple is essentially a wire, it provides a low-impedance path for electrical noise. The noise filter has a response of $>100\text{dB}$ @ 50/60 Hz.



WARNING: A thermocouple can become shorted to a high voltage potential. Because common terminals are internally connected together, whatever voltage potential exists on one thermocouple will exist on the other channels.

Ambient Variations in Temperature

The F0-04THM module has been designed to operate within the ambient temperature range of 0°C to 60°C.

The cold junction compensation is calibrated to operate in a still-air environment. If the module is used in an application that has forced convection cooling, an error of 2–3 °C may be introduced. To compensate for this you can use ladder logic to correct the values.

When configuring the system design it is best to locate any heat-producing devices above and away from the PLC chassis because the heat will affect the temperature readings. For example, heat introduced at one end of the terminal block can cause a channel-to-channel variation.

When exposing the F0-04THM module to abrupt ambient temperature changes it will take several minutes for the cold junction compensation and terminal block to stabilize. Errors introduced by abrupt ambient temperature changes will be less than 4°C.

Module Operation

Channel Scanning Sequence

The DL05 and DL06 read the data from all four input channels during each scan. The CPUs support special V-memory locations that are used to manage the data transfer. This is discussed in more detail on the following page, “Special V-memory Locations”.

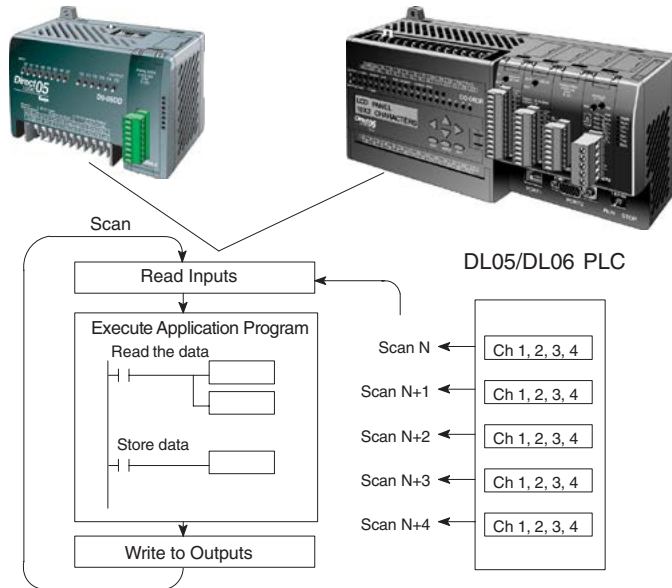

Analog Module Update

Even though the channel updates to the CPU are synchronous with the CPU scan, the module asynchronously monitors the analog transmitter signal and converts the signal to a 16-bit binary representation. This enables the module to continuously provide accurate measurements without slowing down the discrete control logic in the RLL program.

The time required to sense the temperature and copy the value to V-memory is 270 milliseconds minimum to 1080 milliseconds plus 1 scan time maximum (number of channels x 270 milliseconds + 1 scan time).

Special V-memory Locations

The DL05 and DL06 PLCs have special V-memory locations assigned to their respective option slots. These V-memory locations allow you to:

- Specify the number of input channels enabled and BCD/Binary data format
- Specify the input pointer address
- Specify the thermocouple or voltage input type
- Specify the units code – temperature scale and data format
- Enable/disable thermocouple burnout detection
- Specify burnout data value at burnout
- Read module setup diagnostics

Module Configuration Registers

The table below shows the special V-memory locations used by the DL05 and DL06 PLCs for the F0-04THM module.

Module Configuration Parameters	DL05 and DL06 Option Slot				
	DL05 Slot	DL06 Slot 1	DL06 Slot 2	DL06 Slot 3	DL06 Slot 4
A: Number of Channels Enabled / Data Format	V7700	V700	V710	V720	V730
B: Input Pointer	V7701	V701	V711	V721	V731
C: Input Type	V7703	V703	V713	V723	V733
D: Units Code	V7704	V704	V714	V724	V734
E: Thermocouple Burnout Detection Enable	V7705	V705	V715	V725	V735
F: Thermocouple Burnout Data Value	V7706	V706	V716	V726	V736
G: Diagnostic Error	V7707	V707	V717	V727	V737

A: Number of Channels Enabled/Data Format Register

This V-memory location is used to define the number of input channels to be enabled and to set the channel data to BCD or binary format.

Number of Channels Enabled	Channel Data in BCD Format	Channel Data in Binary Format
1 Channel	K100	K8100
2 Channels	K200	K8200
3 Channels	K300	K8300
4 Channels	K400	K8400

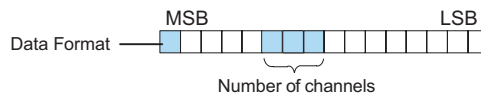

B: Input Pointer Register

This is a system parameter that points to a V-memory location used for storing module channel input data. The V-memory location loaded in the input pointer V-memory location is an octal number identifying the first V-memory location for the input data. This V-memory location is user defined, but must use available consecutive V-memory locations. For example, loading O2000 causes the pointer to write Ch 1's data value to V2000/2001, Ch 2's data value to V2002/2003, CH 3's data value to V2004/2005 and Ch 4's data value to V2006/2007.



NOTE: Each channel's data value occupies two (2) consecutive V-memory locations. This allows for more than four (4) digits to be displayed if a BCD format for channel data is selected. For example: 1234.5 °F. A binary format for either a 15-bit magnitude plus sign or 16-bit 2's complement value will occupy the first V-memory location of the two V-memory locations assigned for the selected channel. Refer to the specific PLC's user manual being used for available user V-memory locations.

C: Input Type Selection Register

This V-memory register must be set to match the type of thermocouple being used or the input voltage level. Use the table to determine your settings.

Thermocouple/ Voltage Input Type	Input Selection	Temperature Range °C	Temperature Range °F
J	K0	-190 to 760	-310 to 1400
K	K1	-150 to 1372	-238 to 2502
E	K2	-210 to 1000	-346 to 1832
R	K3	65 to 1768	149 to 3214
S	K4	65 to 1768	149 to 3214
T	K5	-230 to 400	-382 to 752
B	K6	529 to 1820	984 to 3308
N	K7	-70 to 1300	-94 to 2372
C	K8	65 to 2320	149 to 4208
0-39.0625 mVDC	K9	N/A	N/A
±39.0625 mVDC	KA	N/A	N/A
±78.125 mVDC	KB	N/A	N/A
0-156.25 mVDC	KC	N/A	N/A
±156.25 mVDC	KD	N/A	N/A
0-1.25 VDC	KE	N/A	N/A

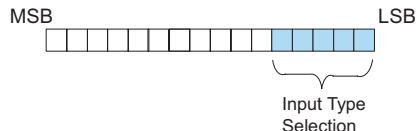

NOTE: The **CJC** functionality is automatically disabled when a Voltage input is selected.

D: Units Code Register

All thermocouple types are converted into a direct temperature reading in either Fahrenheit or Celsius. The data contains one implied decimal place. For example, a value in V-memory of 1002 would be 100.2 °C or °F.

For thermocouple ranges which include negative temperatures (J,E,K,T,N), the display resolution is from -3276.7 to +3276.7. For positive-only thermocouple ranges (R,S,B,C), the display resolution is 0 to 6553.5.

Negative temperatures can be represented in either 2's complement or magnitude plus sign form. If the temperature is negative, the most significant bit in the V-memory location is set.

The 2's complement data format may be required to correctly display bipolar data on some operator interfaces. This data format could also be used to simplify averaging a bipolar signal. To view this data format in *DirectSoft32*, select Signed Decimal.

For unipolar thermocouple ranges (R,S,B,C), it does not matter if magnitude plus sign or 2's complement is selected.

The bipolar voltage input ranges may be converted to a 15-bit magnitude plus sign or a 16-bit 2's complement value.

Bit 0 = Temperature Scale
(ignored if Voltage input is selected)

- 0 = Temp in degrees F
- 1 = Temp in degrees C

Bit 1 = Data Format
0 = Magnitude plus sign bit format
1 = 2's Complement format

Unit Code Register - Truth Table				
Temperature Scale	Data Format	Bit 1	Bit 0	Value
°F	Magnitude + sign bit	0	0	K0
°C	Magnitude + sign bit	0	1	K1
°F	2's Complement	1	0	K2
°C	2's Complement	1	1	K3

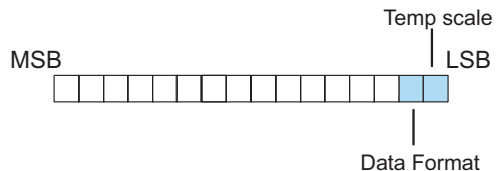

E: Thermocouple Burnout Detection Enable Register

This register is used to enable/disable the thermocouple burnout function. Be sure to disable the burnout detection function when checking the module calibration.

Bit 0 = Thermocouple Burnout Detection Enable/Disable

0 = Burnout detection is enabled

1 = Burnout detection is disabled

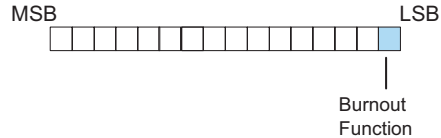

F: Thermocouple Burnout Data Value Register

This register is used to define either up scale or down scale channel values when a channel thermocouple burnout occurs.

Bit 0 = Up scale/down scale value at Burnout

0 = Up scale value at Burnout:

Unipolar input type: FFFFh (BCD/HEX) or 65535 (Binary)
written to CH register

Bipolar input type: 7FFFh (BCD/HEX) or 32767 (Binary)
written to CH register

1 = Down scale value at Burnout:

0000h (BCD/HEX) or 0 (Binary) written to CH register

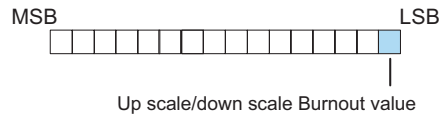

G: Diagnostics Error Register

This register is used to determine whether the configuration of the module is valid or not. It is controlled by the PLC and is read only.

Bit 0 = Diagnostic bit:

0 = Module setup is valid

1 = Module setup is not valid

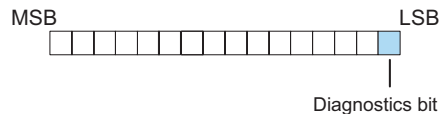

Configuring the Module in Your Control Program

DL05 Example 1

The example program below shows how to setup the F0-04THM for 4 input channels enabled, J type thermocouple on all 4 input channels, BCD channel data format, Fahrenheit (°F) temperature scale, magnitude plus sign bit format, and burnout detection enabled with an up scale burnout specified. Place this rung anywhere in the ladder program or in the initial stage if you are using stage programming instructions.

This is all that is required to read the temperature or voltage input data into V-memory locations. Once the data is in V-memory you can perform mathematical calculations with the data, compare the data against preset values, etc. V2000 is used in the example but you can use any user V-memory location.

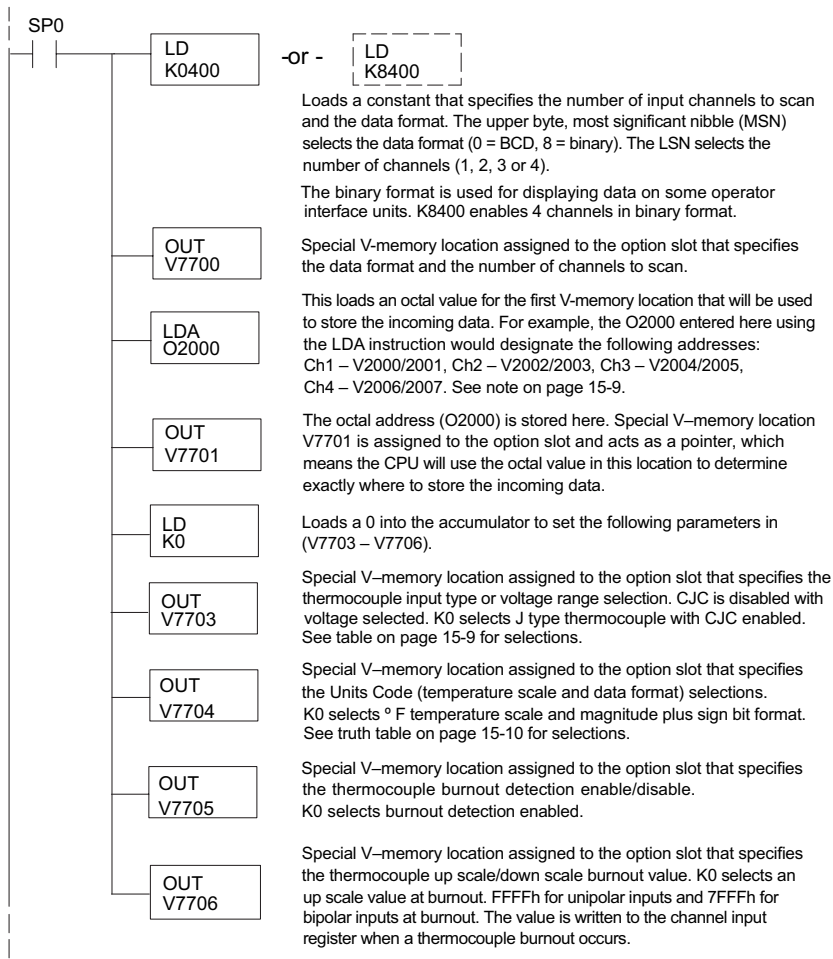

DL05 Example 2

The example program below shows how to setup the F0-04THM for 2 input channels enabled, use of a K type thermocouple on the first 2 input channels, BCD channel data format, Celsius (°C) temperature scale, 2's complement format, and burnout detection enabled with a down scale burnout specified. Again, place this rung in the ladder program or in the initial stage if you are using stage programming instructions.

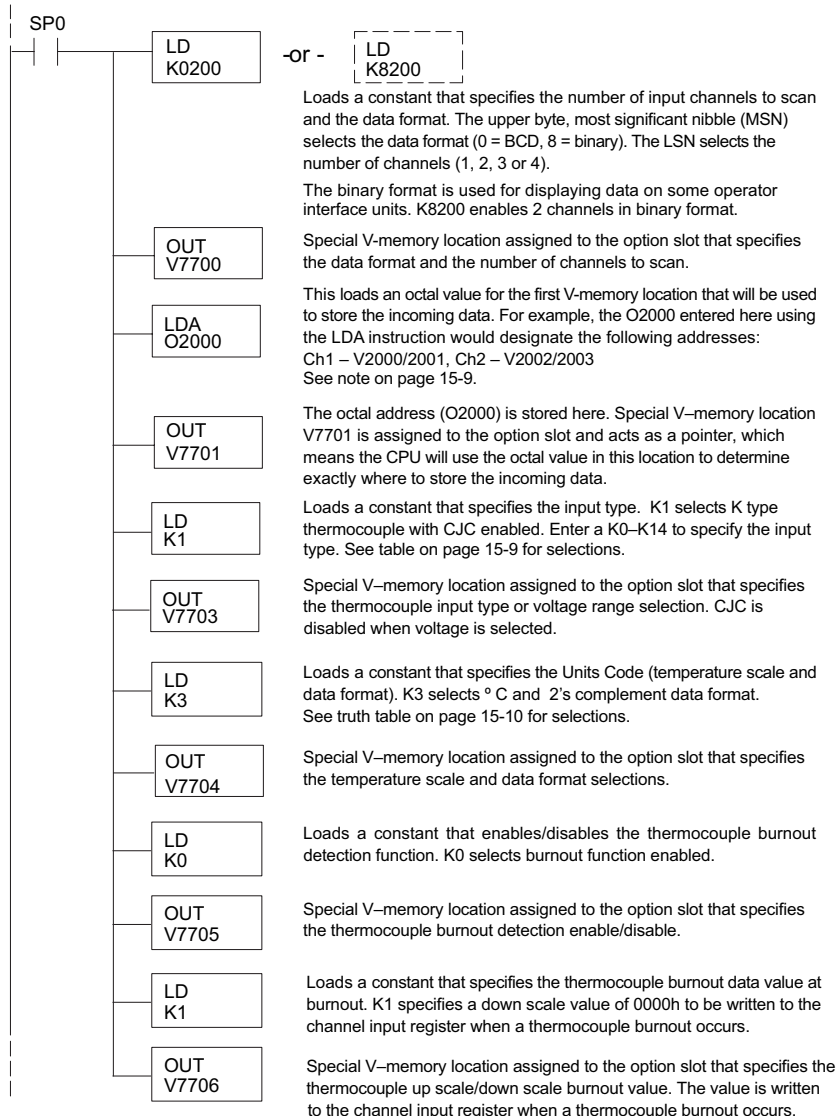

DL06 Example 1

The example program below shows how to setup the F0-04THM in option slot 1 for 4 input channels enabled, use of a J type thermocouple on all 4 input channels, BCD channel data format, Fahrenheit (°F) temperature scale and magnitude plus sign bit format, and burnout detection enabled with an up scale burnout specified. Use the table shown on page 15-8 to determine the pointer values if locating the module in any of the other slots. Place this rung anywhere in the ladder program or in the initial stage if you are using stage programming instructions.

This is all that is required to read the temperature or voltage input data into V-memory locations. Once the data is in V-memory you can perform mathematical calculations with the data, compare the data against preset values, etc. V2000 is used in the example but you can use any user V-memory location.

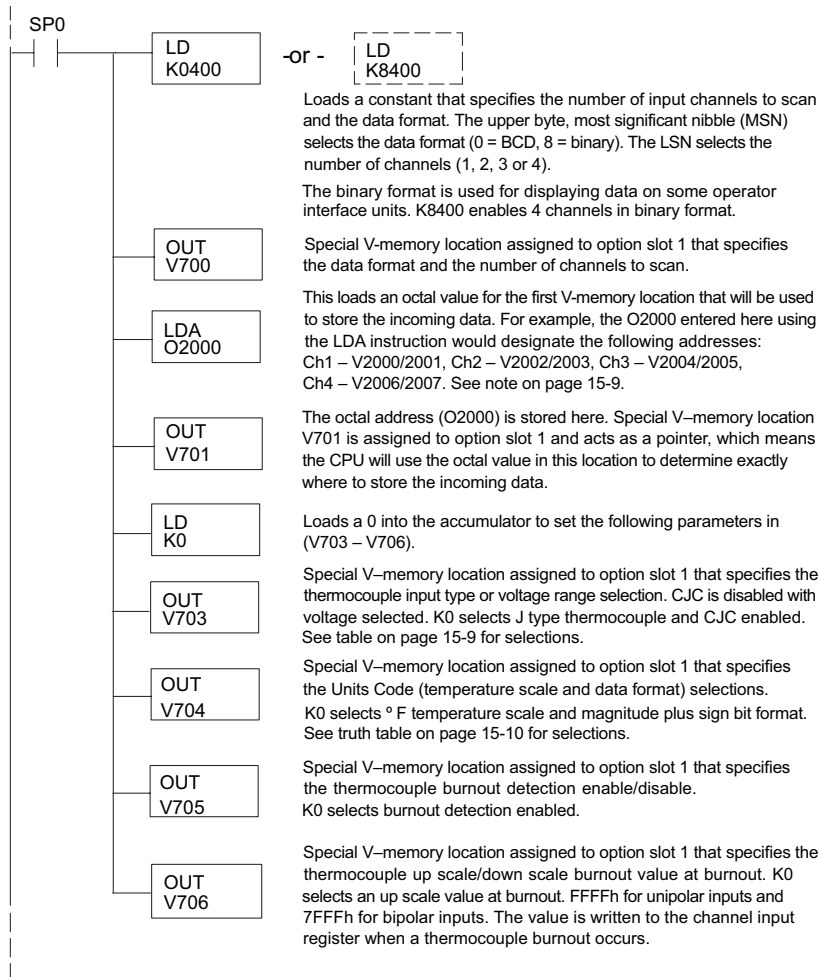

DL06 Example 2

The example program below shows how to setup the F0-04THM in option slot 2 for 2 input channels enabled, use of a K type thermocouple on the first 2 input channels, BCD channel data format, Celsius (°C) temperature scale, 2's complement format, and burnout detection enabled with a down scale burnout specified. Use the table shown on page 15-8 to determine the pointer values if locating the module in any of the other slots. V-memory location V3000 is shown in the example, but you can use any available user V-memory location. Again, place this rung anywhere in the ladder program or in the initial stage if you are using stage programming instructions.

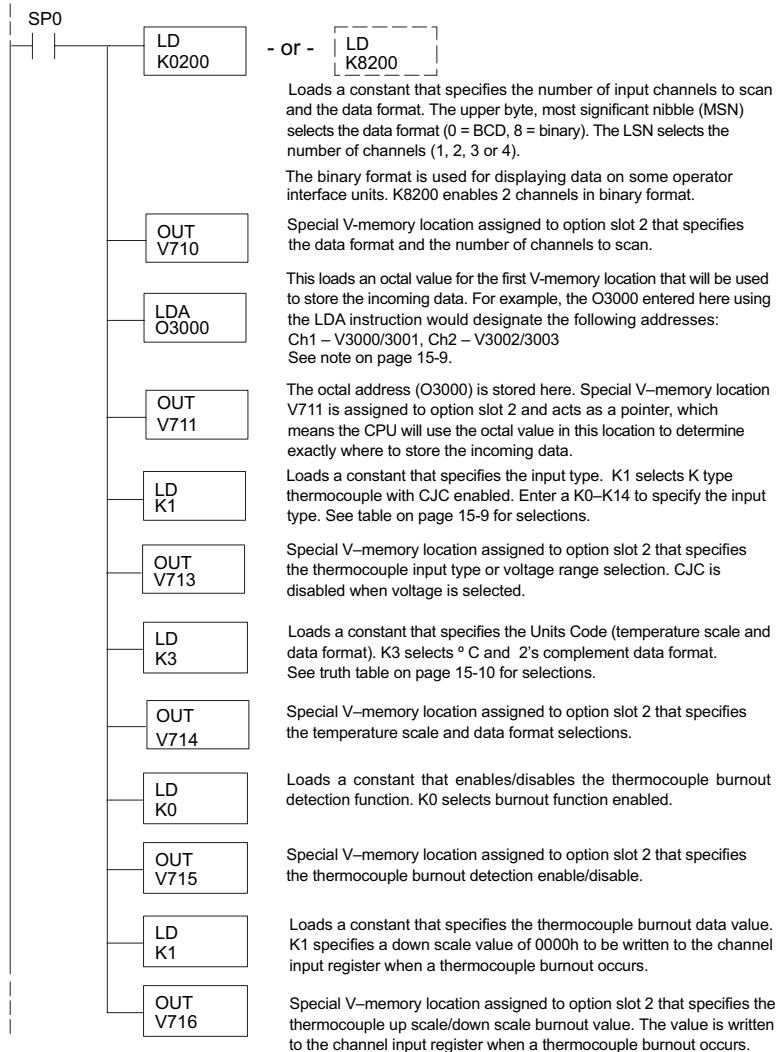

Negative Temperature Readings with Magnitude Plus Sign

With bipolar ranges, you need some additional logic to determine whether the value being returned represents a positive temperature/voltage or a negative temperature/voltage. There is a simple solution:

- If you are using bipolar ranges and you get a value greater than or equal to 8000h, the value is negative.
- If you get a value less than or equal to 7FFFh, the value is positive.

The sign bit is the most significant bit, which combines 8000h to the data value. If the value is greater than or equal to 8000h, you only have to mask the most significant bit and the active channel bits to determine the actual data value.

The following two programs show how you can accomplish this. The first example uses magnitude plus sign (binary) and the second example uses magnitude plus sign (BCD).

Since you always want to know when a value is negative, these rungs should be placed before any other operations that use the data, such as math instructions, scaling operations, and so forth. Also, if you are using stage programming instructions, these rungs should be in a stage that is always active. Note: you only need this logic for each channel that is using bipolar input signals. The examples only show two channels.

Magnitude Plus Sign (Binary)

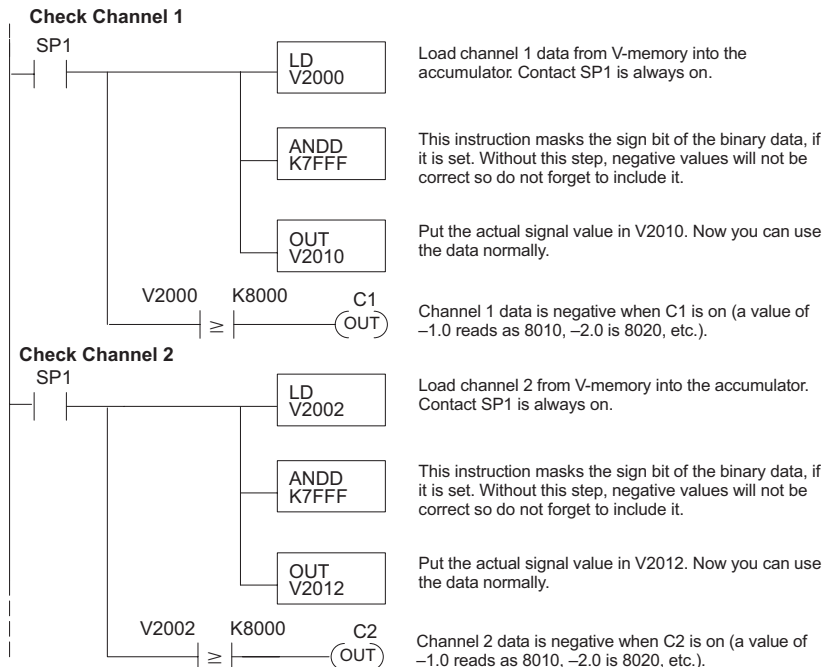

Magnitude Plus Sign (BCD)

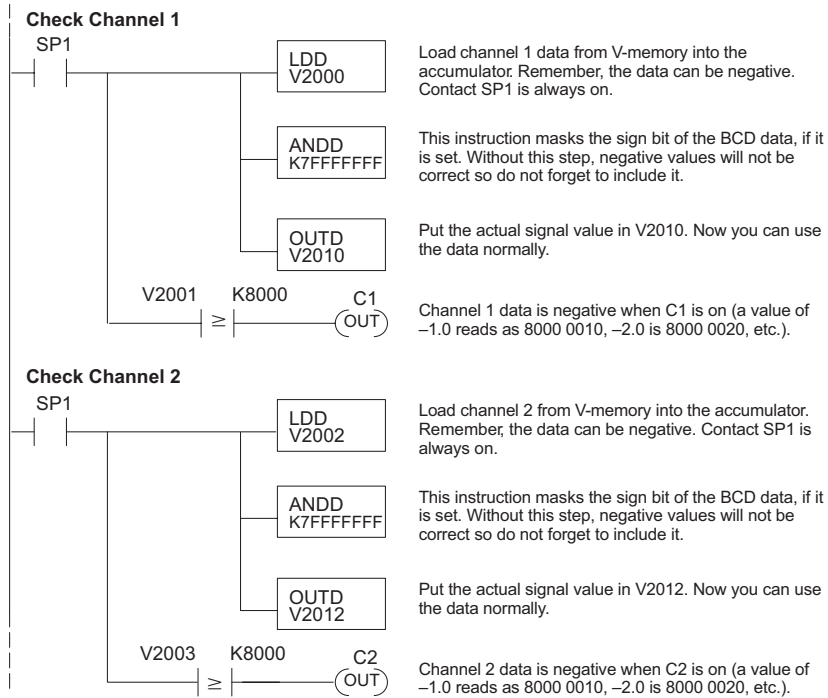

Module Resolution

Module Resolution 16-Bit (Unipolar Voltage Input)

Unipolar analog signals are converted into 65536 (2^{16}) counts ranging from 0 to 65535. For example, with a 0 to 156.25 mVDC signal range, 78 mVDC would be 32767. A value of 65535 represents the upper limit of the range.

$$\text{Unipolar Resolution} = \frac{H - L}{65535}$$

H or L = high or low limit of the range

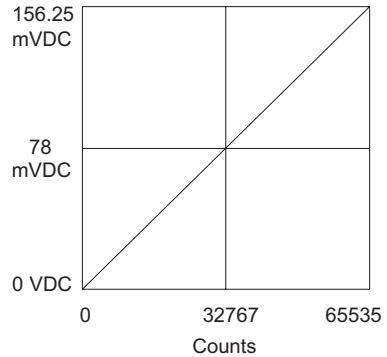

Module Resolution 15-Bit Plus Sign (Bipolar Voltage Input)

The module has 16-bit unipolar or 15-bit + sign bipolar resolution. Bipolar analog signals are converted into 32768 (2^{15}) counts ranging from 0 to 32767. For example, with a -156.25 mVDC to 156.25 mVDC input signal range, 156.25 mVDC would be 32767. The bipolar ranges utilize a sign bit to provide 16-bit resolution. A value of 32767 can represent the upper limit of either side of the range. Use the sign bit to determine negative values.

$$\text{Bipolar Resolution} = \frac{H - L}{32767}$$

H or L = high or low limit of the range

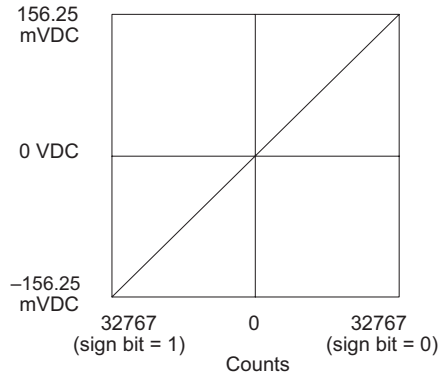

Analog Input Ladder Logic Filter

PID Loops / Filtering

Please refer to the “PID Loop Operation” chapter in the DL06 or DL05 User Manual for information on the built-in PV filter (DL05/06) and the ladder logic filter (DL06 only) shown below. A filter must be used to smooth the analog input value when auto tuning PID loops to prevent giving a false indication of loop characteristics.

Smoothing the Input Signal (DL06 only)

The filter logic can also be used in the same way to smooth the analog input signal to help stabilize PID loop operation or to stabilize the analog input signal value for use with an operator interface display, etc.



WARNING: The built-in and logic filters are not intended to smooth or filter noise generated by improper field device wiring or grounding. Small amounts of electrical noise can cause the input signal to bounce considerably. Proper field device wiring and grounding must be done before attempting to use the filters to smooth the analog input signal.

Using Binary Data Format

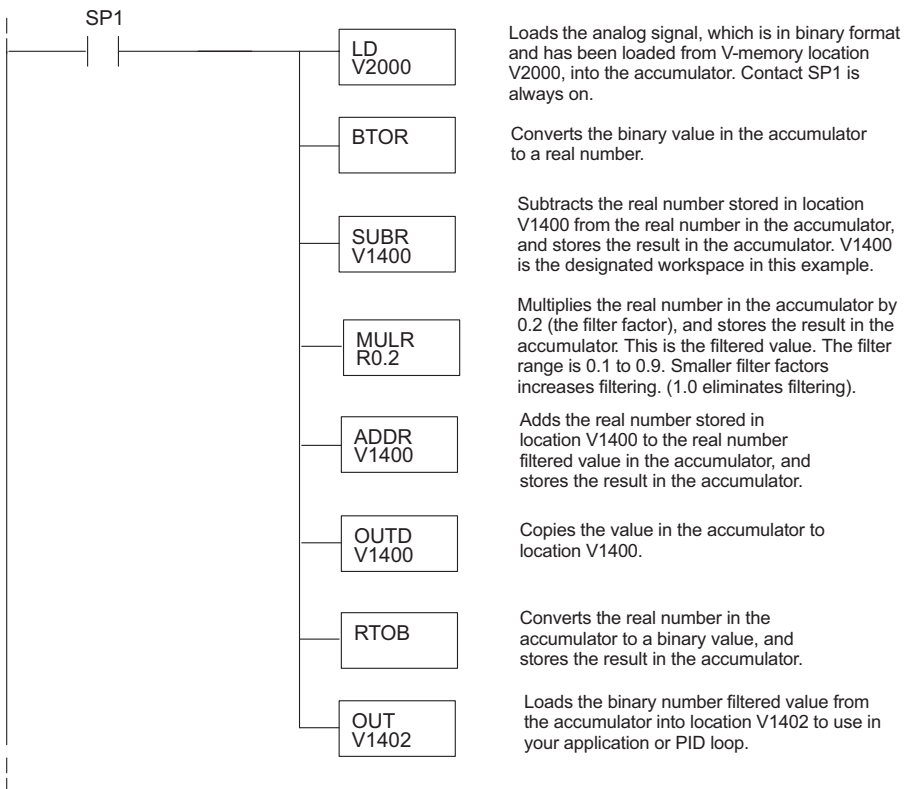



NOTE: Be careful not to do a multiple number conversion on a value. For example, if you are using the pointer method in BCD format to get the analog value, it must be converted to binary (BIN) as shown below. If you are using the pointer method in Binary format, the conversion to binary (BIN) instruction is not needed.

Using BCD Data Format

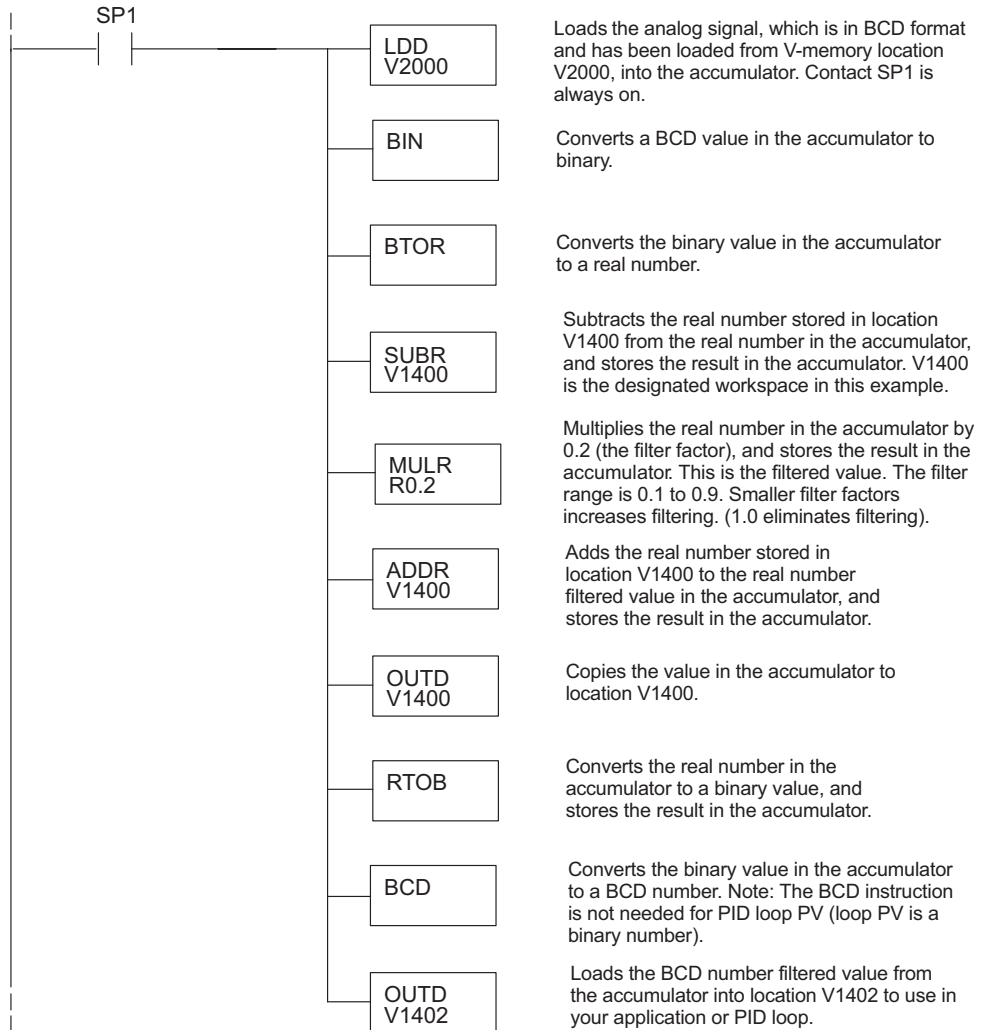

Thermocouple Burnout Detection Bits

Special Relays Corresponding to Thermocouple Burnouts

The following Special Relay (SP) bits can be used in your program to monitor for thermocouple burnout.

SP bit :

0 = Thermocouple OK

1 = Thermocouple burnout

Module Channel	DL05 and DL06 Option Slot				
	DL05 Slot	DL06 Slot 1	DL06 Slot 2	DL06 Slot 3	DL06 Slot 4
Channel 1	SP600	SP140	SP240	SP340	SP440
Channel 2	SP601	SP141	SP241	SP341	SP441
Channel 3	SP602	SP142	SP242	SP342	SP442
Channel 4	SP603	SP143	SP243	SP343	SP443