

High-Speed Input and Pulse Output Features

In This Chapter. . . .

- Introduction
 - Choosing the HSIO Operating Mode
 - Mode 10: High-Speed Counter
 - Mode 20: Quadrature Counter
 - Mode 30: Pulse Output
 - Mode 40: High-Speed Interrupt
 - Mode 50: Pulse Catch Input
 - Mode 60: Filtered Inputs
-

Introduction

Built-in Motion Control Solution

Many machine control applications require various types of simple high-speed monitoring and control. These applications usually involve some type of motion control, or high-speed interrupts for time-critical events. The DL105 Micro PLC solves this traditionally expensive problem with built-in CPU enhancements. Let's take a closer look at the available high-speed I/O features.

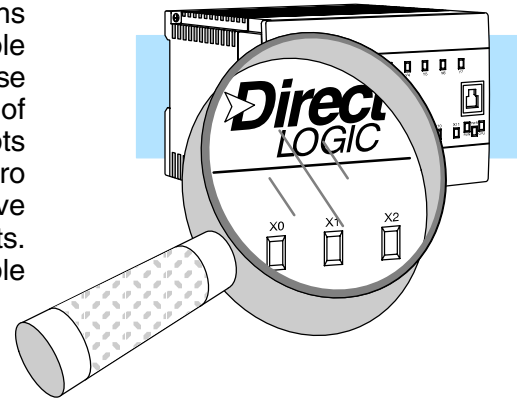

The available **high-speed input features** are:

- High Speed Counter (5 kHz max.) with up to 24 counter presets and built-in interrupt subroutine, counts up only, with reset
- Quadrature encoder inputs to measure counts and clockwise or counter clockwise direction (5 kHz max.), counts up or down, with reset
- High-speed interrupt input for immediate response to critical or time-sensitive tasks
- Pulse catch feature to monitor one input point, having a pulse width as small as 100µS (0.1ms)
- Programmable discrete filtering (both on and off delay up to 99ms) to ensure input signal integrity (this is the default mode for inputs X0–X3)

The available **pulse output features** are:

- Single-axis programmable pulse output (7 kHz max.) with three profile types, including trapezoidal moves, registration, and velocity control

IMPORTANT: Please note the following restrictions on availability of features:

- High-speed input options are available only on DL105s with DC inputs.
- Pulse output options are available only on DL105s with DC outputs.
- Only one HSIO feature may be in use at one time. You cannot use a high-speed input feature and the pulse output at the same time.

Availability of HSIO Features

DL105 Part Number	Discrete Input Type	Discrete Output Type	High-Speed Input	Pulse Output
F1-130AR	AC	Relay	No	No
F1-130DR	DC	Relay	Yes	No
F1-130AD	AC	DC	No	Yes
F1-130DD	DC	DC	Yes	Yes
F1-130AA	AC	AC	No	No
F1-130DA	DC	AC	Yes	No
F1-130DR-D	DC	Relay	Yes	No
F1-130DD-D	DC	DC	Yes	Yes

Dedicated High-Speed I/O Circuit

The internal CPU's main task is to execute the ladder program and read/write all I/O points during each scan. In order to service high-speed I/O events, the DL105 includes a special circuit which is dedicated to a portion of the I/O points. Refer to the DL105 block diagram in the figure below.

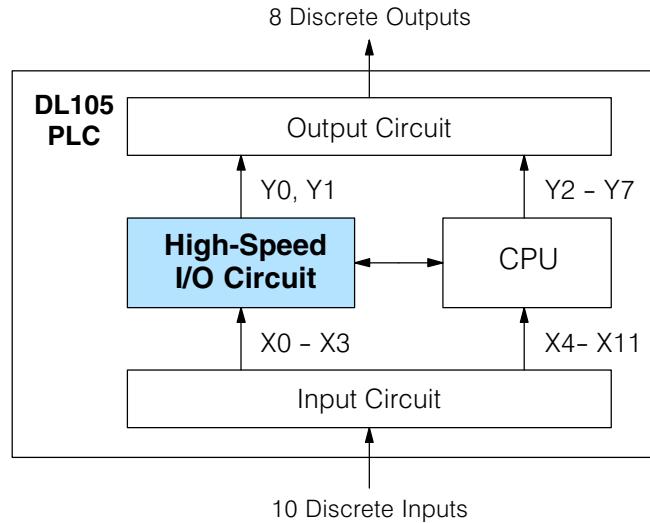

The high-speed I/O circuit (HSIO) is dedicated to the first four inputs (X0 – X3) and the first two outputs (Y0 – Y1). We might think of this as a “CPU helper”. In the default operation (called “Mode 60”) the HSIO circuit just passes through the I/O signals to or from the CPU, so that all ten inputs behave equally and all eight outputs behave equally. When the CPU is configured in any other HSIO Mode, the HSIO circuit imposes a specialized function on the portion of inputs and outputs shown. The HSIO circuit *operates independently of the CPU program scan*. This provides accurate measurement and capturing of high-speed I/O activity while the CPU is busy with ladder program execution.

Wiring Diagrams for Each HSIO Mode

After choosing the appropriate HSIO mode for your application, you’ll need to refer to the section in this chapter for that specific mode. Each section includes wiring diagram(s) to help you connect the High-Speed I/O points correctly to field devices. An example of the quadrature counter mode diagram is shown below.

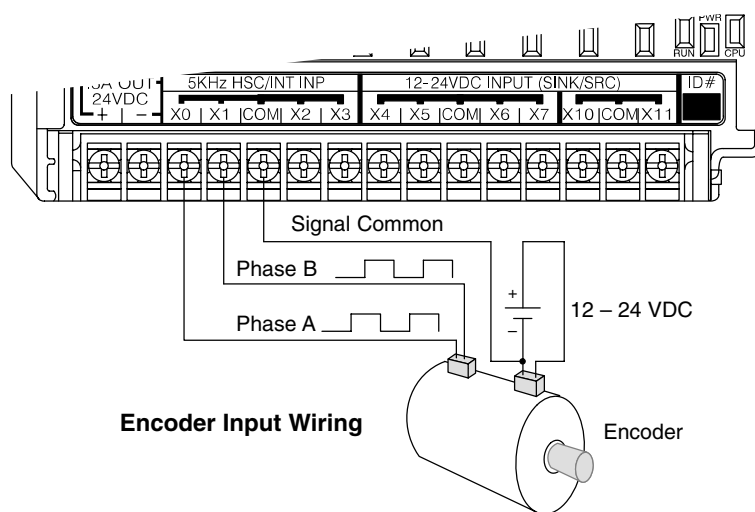

Choosing the HSIO Operating Mode

Understanding the Six Modes

The High-Speed I/O circuit operates in one of 6 basic modes as listed in the table below. The number in the left column is the mode number (later, we'll use these numbers to configure the PLC). Choose one of the following modes according to the primary function you want from the dedicated High-Speed I/O circuit. You can simply use all ten inputs and eight outputs as regular I/O points with Mode 60.

Mode Number	Mode Name	Mode Features
10	High-Speed Counter	5 kHz counter with 24 presets and reset input, counts up only, causes interrupt on preset
20	Quadrature Counter	Channel A / Channel B 5 kHz quadrature input, counts up and down
30	Pulse Output	Stepper control – pulse and direction signals, programmable motion profile
40	High-Speed Interrupt	Generates an interrupt based on input transition or time
50	Pulse Catch	Captures narrow pulses on a selected input
60	Discrete/Filtered Input	Rejects narrow pulses on selected inputs

In choosing one of the six high-speed I/O modes, the I/O points listed in the table below operate only as the function listed. If an input point is not specifically used to support a particular mode, it usually operates as a filtered input by default. Similarly, output points operate normally unless Pulse Output mode is selected.

Physical I/O Point Usage						
Mode	DC Input Points				DC Output Points	
	X0	X1	X2	X3	Y0	Y1
High-Speed Counter	Counter clock	Filtered Input	Filtered Input or Reset Cnt	Filtered Input	Regular Output	Regular Output
Quadrature Counter	Phase A Input	Phase B Input	Filtered Input or Reset Cnt	Filtered Input	Regular Output	Regular Output
High-Speed Interrupt	Interrupt Input, or Filtered Input	Filtered Input	Filtered Input	Filtered Input	Regular Output	Regular Output
Pulse Catch	Pulse Input	Filtered Input	Filtered Input	Filtered Input	Regular Output	Regular Output
Pulse Output	Not available	Filtered Input	Filtered Input, or Interrupt to trigger pulse output	Filtered Input	Pulse or CW Pulse	Direction or CCW Pulse
Filtered Input	Filtered Input	Filtered Input	Filtered Input	Filtered Input	Regular Output	Regular Output

Default Mode

Mode 60 (Filtered Inputs) is the default mode. The DL105 is initialized to this mode at the factory, and any time you clear V-memory scratchpad. In the default condition, X0–X3 are filtered inputs (10 mS delay) and Y0–Y1 are standard outputs.

Configuring the HSIO Mode

If you have chosen a mode suited to the high-speed I/O needs of your application, we're ready to proceed to configure the PLC to operate accordingly. In the block diagram below, notice the V-memory detail in the expanded CPU block. V-memory location **V7633** determines the functional mode of the high-speed I/O circuit. *This is the most important V-memory configuration value for HSIO functions!*

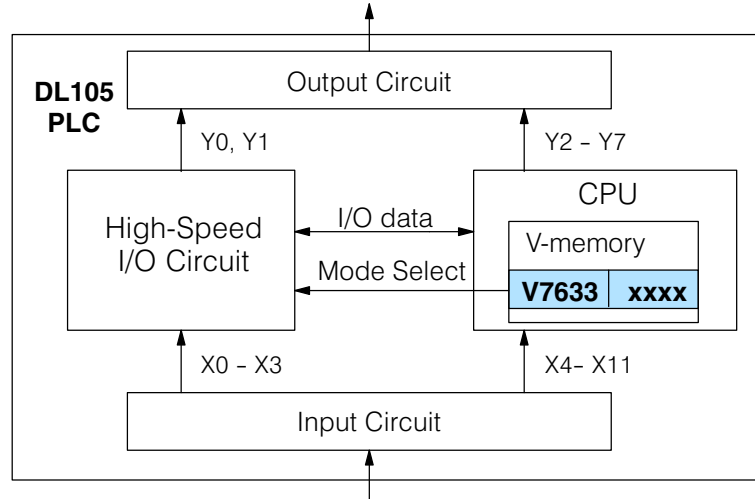

The contents of V7633 is a 16-bit word, to be entered in binary-coded decimal. The figure below defines what each 4-bit BCD digit of the word represents.

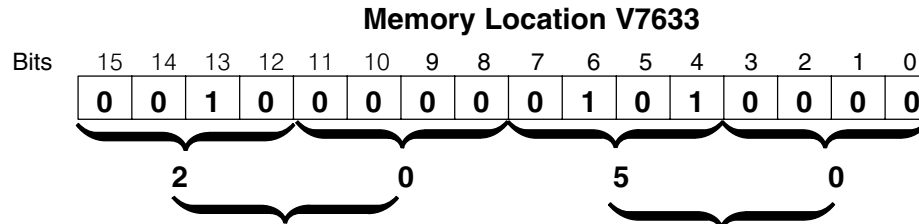

Miscellaneous Setup (BCD)

- 00 = Power Up in Previous Mode
- 20 = Power Up in Run Mode Always

HSIO Mode Setup (BCD)

- 00 = Not Used
- 10 = High-Speed Counting Mode
- 20 = Quadrature Counting Mode
- 30 = Pulse Output Train
- 40 = High-Speed Interrupts
- 50 = Pulse Catching
- 60 = Discrete Filtered Inputs (default)

Bits 0 – 7 define the mode number 00, 10.. 60 previously referenced in this chapter. The example data “2050” shown selects Mode 50 – Pulse Catch (BCD = 50) and Power Up in Run Mode (BCD=20). Together they form the 4-digit BCD number 2050.

Configuring Inputs X0 – X3

In addition to configuring V7633 for the HSIO mode, you'll need to program the next four locations in certain modes according to the desired function of input points X0 – X3. Other memory locations may require configuring, depending on the HSIO mode (see the corresponding section for particular HSIO modes).

V-memory		
Mode	V7633	xxxx
X0	V7634	xxxx
X1	V7635	xxxx
X2	V7636	xxxx
X3	V7637	xxxx

Mode 10: High-Speed Counter

Purpose

The HSIO circuit contains one high-speed counter. A single pulse train from an external source (X0) clocks the counter on each signal leading edge. The counter counts only upwards, from 0 to 99999999. The counter compares the current count with up to 24 preset values, which you define. The purpose of the presets is to quickly cause an action upon arrival at specific counts, making it ideal for such applications as cut-to-length. It uses counter registers CT76 and CT77 in the CPU.

Functional Block Diagram

Refer to the block diagram below. When the lower byte of HSIO Mode register V7633 contains a BCD "10", the high-speed up counter in the HSIO circuit is enabled. X0 automatically becomes the "clock" input for the high-speed counter, incrementing it upon each off-to-on transition. The external reset input on X2 is the default configuration for Mode 10. Inputs X1 and X3 are filtered inputs, available to the ladder program.

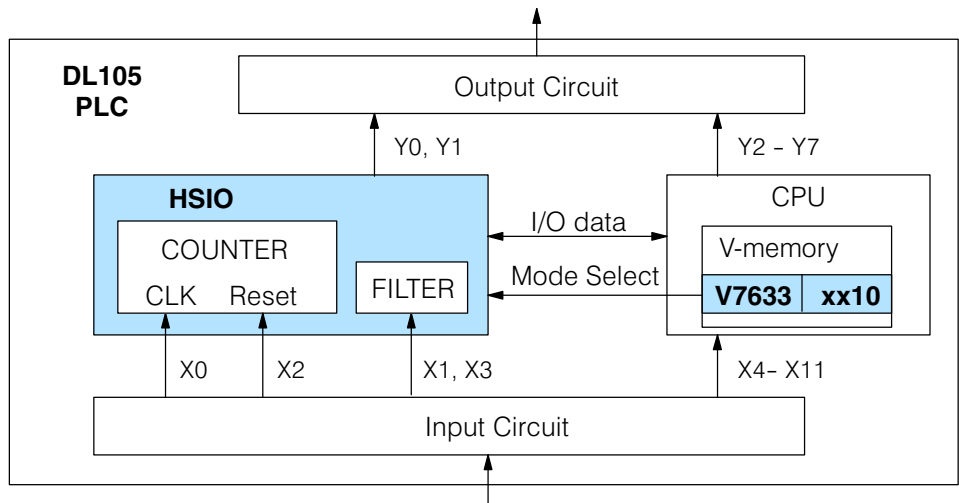

Instead of using X2 as a dedicated reset input, you can configure X2 as a normal filtered input. In this way, the counter reset must be generated in ladder logic.

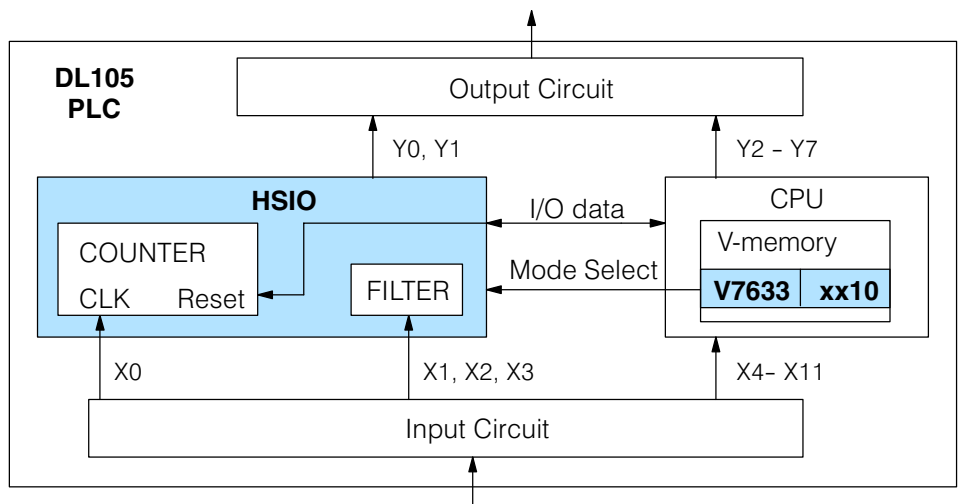

Next, we will discuss how to program the high-speed counter and its presets.

High-Speed Input and Pulse Output Features

Wiring Diagram

A general wiring diagram for counters/encoders to the DL105 in HSIO Mode 10 is shown below. Many types of pulse-generating devices may be used, such as proximity switches, single-channel encoders, magnetic or optical sensors, etc. Devices with sinking outputs (NPN open collector) are probably the best choice for interfacing. If the counter sources to the inputs, it must output 12 to 24 VDC. Note that devices with 5V sourcing outputs will not work with DL105 inputs.

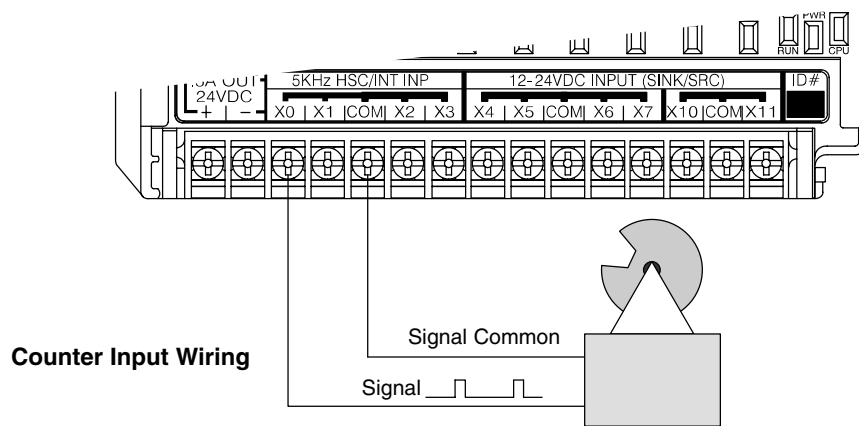

Interfacing to Counter Outputs

The DL105's DC inputs are flexible in that they detect current flow in either direction, so they can be wired to a counter with either sourcing or sinking outputs. In the following circuit, a counter has open-collector NPN transistor outputs. It sinks current from the PLC input point, which sources current. The power supply can be the +24VDC auxiliary supply or another supply (+12VDC or +24VDC), as long as the input specifications are met.

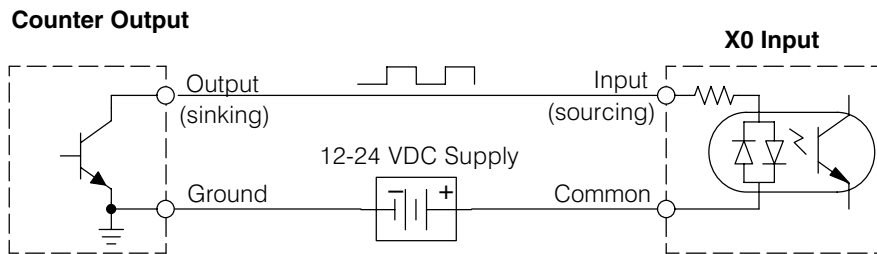

In the next circuit, an encoder has open-emitter PNP transistor outputs. It sources current to the PLC input point, which sinks the current back to ground. Since the encoder sources current, no additional power supply is required. However, note that the encoder output must be 12 to 24 volts (5V encoder outputs will not work).

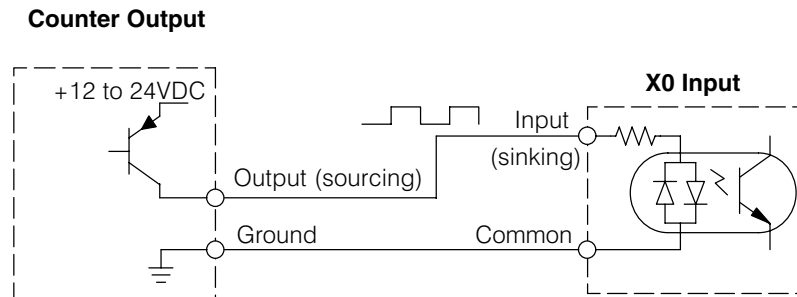

High-Speed Input and Pulse Output Features

Setup for Mode 10 Recall that V7633 is the HSIO Mode Select register. Refer to the diagram below. Use BCD 10 in the lower byte to select High-Speed Counter Mode. Use BCD 00 or 20 in the upper byte as required. Combine the two bytes into a data word “xx10”, for writing to V7633.

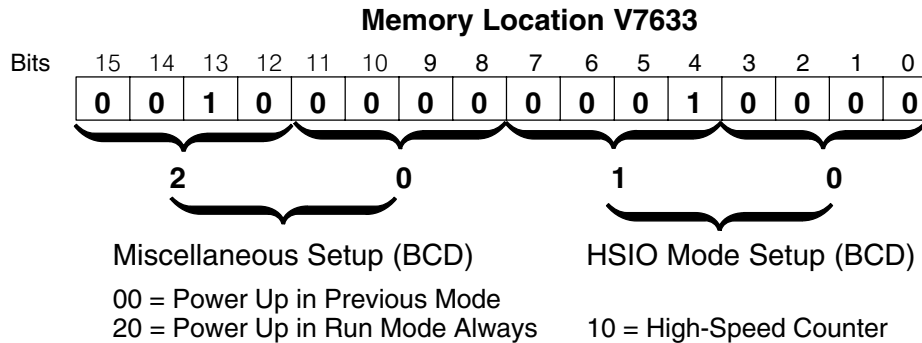

Choose the most convenient method of programming V7633 from the following:

- Include load and out instructions in your ladder program
- **DirectSOFT32's** memory editor
- Use the Handheld Programmer D2-HPP

We recommend using the first method above so that the HSIO setup becomes an integral part of your application program. An example program later in this section shows how to do this.

Presets and Special Relays

The goal of counting is to do a special action when the count reaches a preset value. Refer to the figure below. The counter features 24 presets, which you can program. A preset is a number you derive and store so that the counter will constantly compare the current count with the preset. When the two are equal, a special relay contact is energized and program execution jumps to the interrupt routine. We recommend using the special relay(s) in the interrupt service routine to cause any immediate action you desire. After the interrupt service routine is complete, the CPU returns to the ladder program, resuming program execution from the point of interruption. The compare function is ready for the next preset event.

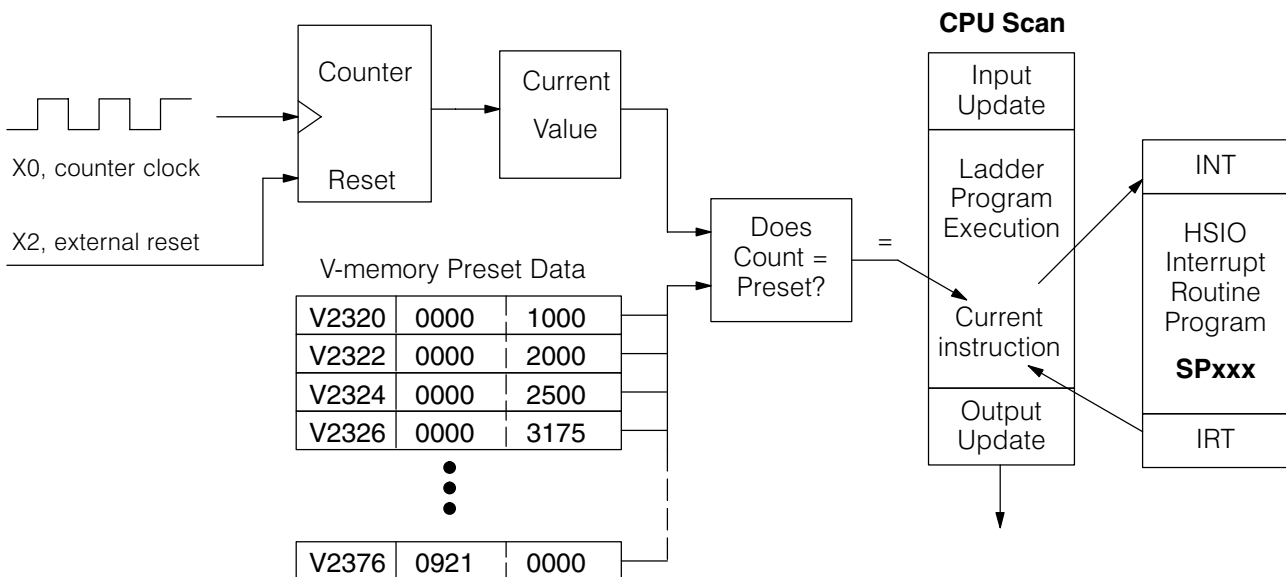

Preset Data Starting Location

V7630 is a pointer location which points to the beginning of the Preset Data Table. The default starting location for the Preset Data Table is V2320 (default after initializing scratchpad V-memory). However, you may change this by programming a different value in V7630. Use the LDA and OUT instructions as shown:

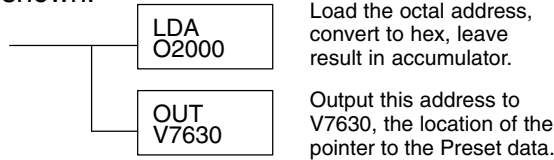

Preset Table Pointer

V7630	2000
-------	------

Preset Data

V2000	0000	1000
V2002	0000	2000
V2004	0000	2500
V2006	0000	3175



V2076	0000	0000
-------	------	------

Using Fewer than 24 Presets

When using fewer than 24 preset registers, the HSIO looks for "0000 FFFF" (use LDD Kfff) in the next preset location to indicate the last preset has been reached. The example to the right uses four presets. The 0000 FFFF in V2331-V2330 indicates the previous preset was the last.

Preset Data

V2320	0000	1000
V2322	0000	2000
V2324	0000	2500
V2326	0000	3175
V2330	0000	FFFF



NOTE: Each successive preset must be greater than the previous preset value. If a preset value is less than a lower-numbered preset value, the CPU cannot compare for that value, since the counter can only count upwards.

Equal Relay Numbers

The following table lists all 24 preset register default locations. Each occupies two 16-bit V-memory registers. The corresponding special relay contact number is in the next column. We might also call these "equal" relay contacts, because they are true (closed) when the present high-speed counter value is equal to the preset value. Each contact remains closed until the counter value equals the next preset value.

Preset	Preset V-memory Register	Special Relay Number	Preset	Preset V-memory Register	Special Relay Number
1	V2321 / V2320	SP540	13	V2351 / V2350	SP554
2	V2323 / V2322	SP541	14	V2353 / V2352	SP555
3	V2325 / V2324	SP542	15	V2355 / V2354	SP556
4	V2327 / V2326	SP543	16	V2357 / V2356	SP557
5	V2331 / V2330	SP544	17	V2361 / V2360	SP560
6	V2333 / V2332	SP545	18	V2363 / V2362	SP561
7	V2335 / V2334	SP546	19	V2365 / V2364	SP562
8	V2337 / V2336	SP547	20	V2367 / V2366	SP563
9	V2341 / V2340	SP550	21	V2371 / V2370	SP564
10	V2343 / V2342	SP551	22	V2373 / V2372	SP565
11	V2345 / V2344	SP552	23	V2375 / V2374	SP566
12	V2347 / V2346	SP553	24	V2377 / V2376	SP567

Calculating Your Preset Values

The preset values occupy two data words each. They can range in value from 0000 0000 to 9999 9999, just like the high-speed counter value. All twenty-four values are *absolute* values, meaning that each one is an offset from the counter zero value.

The preset values must be individually derived for each application. In the industrial lathe diagram below, the PLC monitors the position of the lead screw by counting pulses. At points A, B, and C along the linear travel, the cutter head pushes into the work material and cuts a groove.

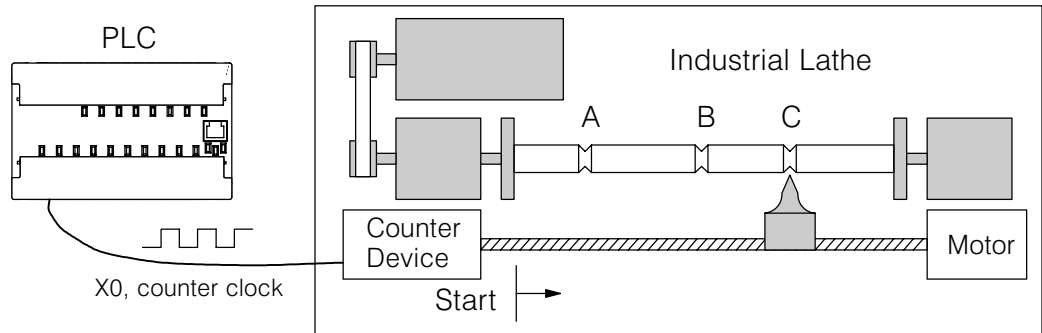

The timing diagram below shows the duration of each equal relay contact closure. Each contact remains on until the next one closes. All go off when the counter resets.

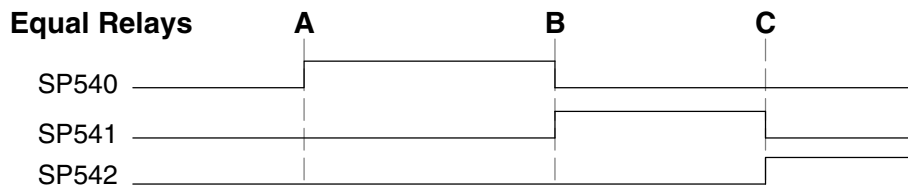

NOTE: Each successive preset must have a greater value than the previous preset value. In the industrial lathe example, $B > A$ and $C > B$.

X Input Configuration

The configurable discrete input options for High-Speed Counter Mode are listed in the table below. Input X0 is dedicated for the counter clock input. Inputs X1 and X3 can only be filtered inputs. The section on Mode 60 operation at the end of this chapter describes programming the filter time constants. Input X2 can be configured as the counter reset, with or without the interrupt option. The interrupt option allows the reset input (X2) to cause an interrupt like presets do, but there is no SP relay contact closure (instead, X2 will be on during the interrupt routine, for 1 scan). Or finally, X2 may be left simply as a filtered input like X1 and X3.

Input	Configuration Register	Function	Hex Code Required
X0	V7634	Counter Clock	0001
X1	V7635	Filtered Input	xx06 (xx = filter time)
X2	V7636	Counter Reset (no interrupt)	0007
		Counter Reset (with interrupt)	0107
		Filtered Input	xx06 (xx = filter time)
X3	V7637	Filtered Input	xx06 (xx = filter time)

Writing Your Control Program

You may recall that the counter instruction is a standard instruction in the DL105 instruction set. Refer to the figure below. The mnemonic for the counter is **UDC** (up-down counter). The DL105 can have up to 64 counters, labeled CT0 through CT77. The high speed counter in the HSIO circuit is accessed in ladder logic by using UDC CT76. It uses counter registers CT76 and CT77 exclusively when the HSIO mode 10 is active (otherwise, CT76 and CT77 are available for standard counter use). The HSIO counter needs two registers because it is a double-word counter. It has three inputs as shown. The first input (Enable) allows counting when active. The middle input (Preload) allows you to change the current count. The bottom signal is the reset. The preload input must be off while the counter is counting.

Standard Counter Function

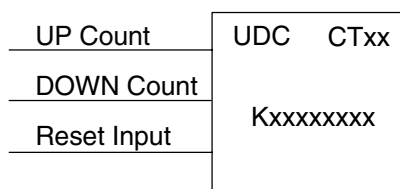

- Counts UP and DOWN
- Preload counter by write to value
- Reset input is internal only

HSIO Counter Function

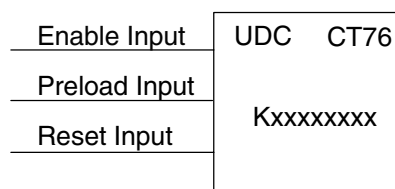

- Counts UP only
- Can use Preload input to change count
- Reset may be internal or external

The next figure shows how the HSIO counter will appear in a ladder program. Note that the Enable Interrupt (ENI) command must execute before the counter value reaches the first preset value. We do this at powerup by using the first scan relay. When using the counter but not the presets and interrupt, we can omit the ENI.

DirectSOFT32

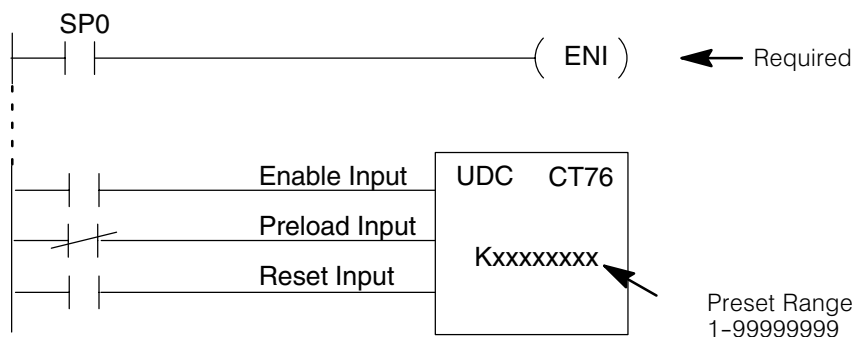

When the enable input is energized, the high-speed counter will respond to pulses on X0 and increment the counter at CT76 – CT77. The reset input contact behaves in a logical OR fashion with the physical reset input X2 (when selected). So, the high speed counter can receive a reset from either the contact(s) on the reset rung in the ladder, OR the external reset X2 if you have configured X2 as an external reset.

Program Example: Counter Without Preset

The following example is the simplest way to use the high-speed counter, which does not use the presets and special relays in the interrupt routine. The program configures the HSIO circuit for Mode 10 operation, so X0 is automatically the counter clock input. It uses the Compare-double (CMPD) instruction to cause action at certain count values. Note that this allows you to have more than 24 “presets”. Then it configures X2 to be the external reset of the counter.

Program Example Cont'd

DirectSOFT32 First Scan Only

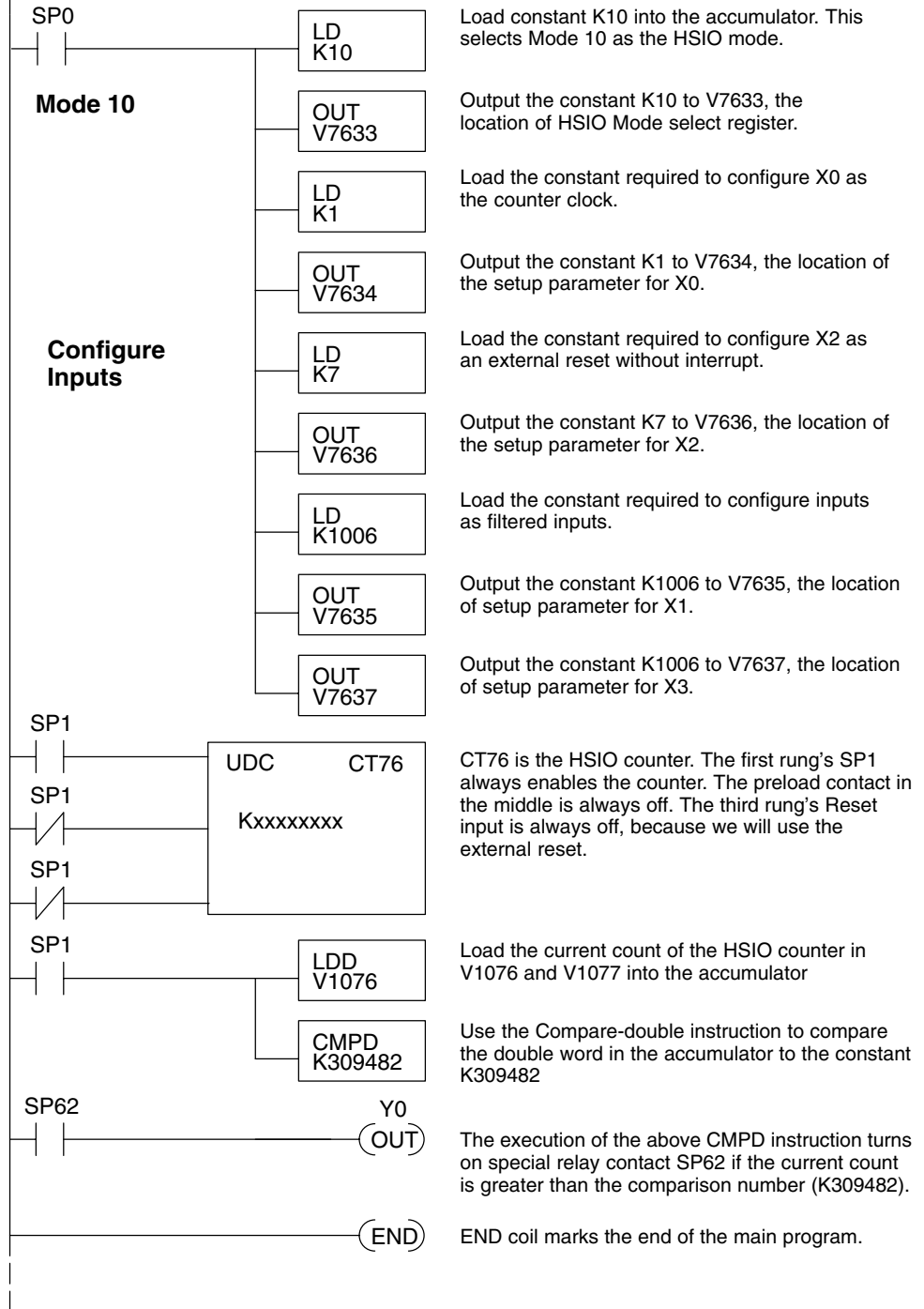

The compare double instruction above uses the current count of the HSIO counter to turn on Y0. This technique can make more than 24 comparisons, but it is scan-time dependent. However, use the 24 built-in presets with the interrupt routine if your application needs a very fast response time, as shown in the next example.

Counter With Presets Program Example

The following example shows how to program the HSIO circuit to trigger on three preset values. You may recall the industrial lathe example from the beginning of this chapter. This example program shows how to control the lathe cutter head to make three grooves in the work-piece at precise positions. When the lead screw turns, the counter device generates pulses which the DL105 can count. The three preset variables A, B, and C represent the positions (number of pulses) corresponding to each of the three grooves.

Preset Data

A	V2320	0000	1500
B	V2322	0000	3780
C	V2324	0000	4850
	V2326	0000	FFFF

I/O Assignments
 X4 - Cutter head extended
 X5 - Cutter head retracted
 Y0 - Lead screw motor
 Y1 - Cutter head solenoid

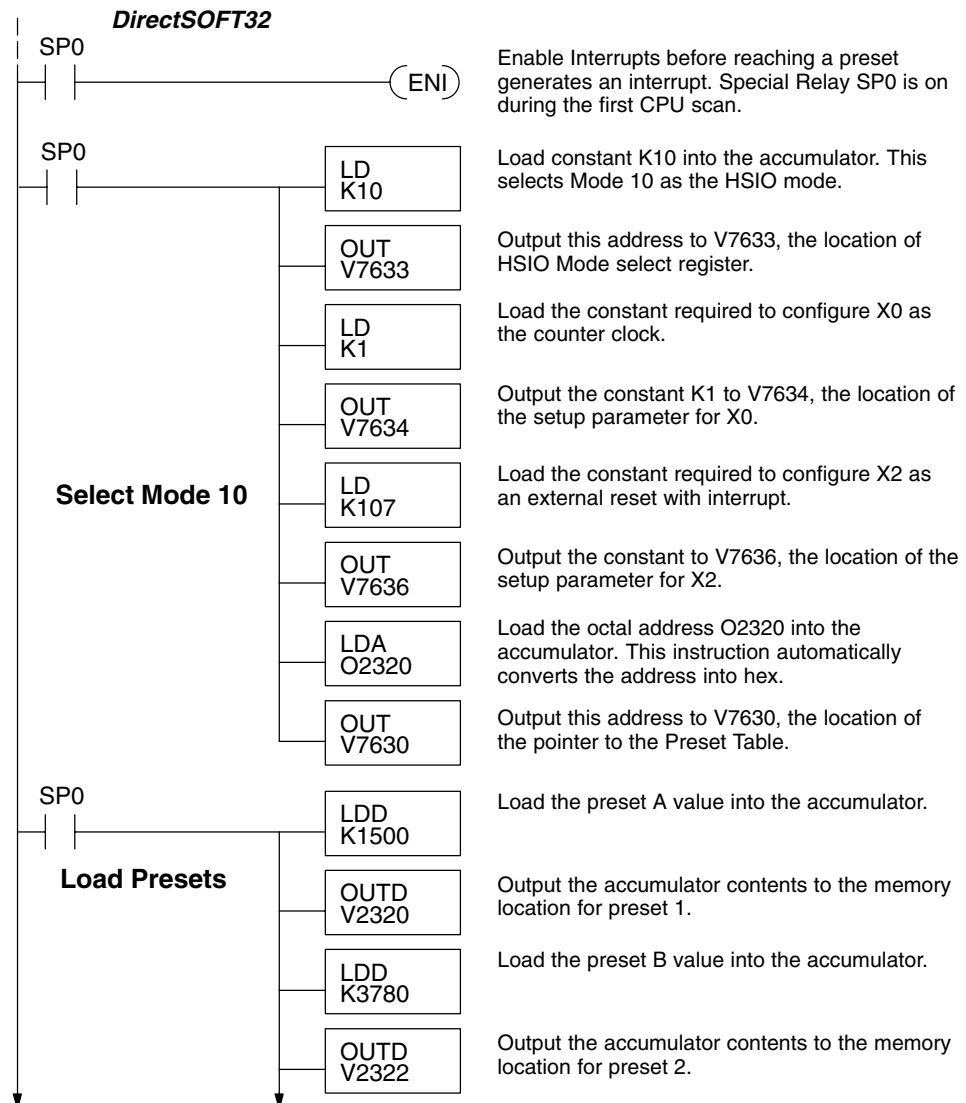
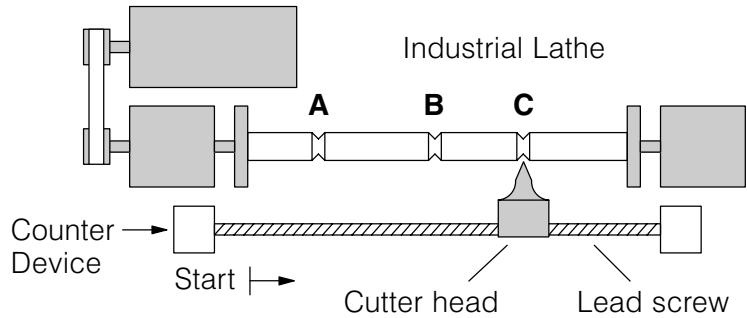

High-Speed Input and Pulse Output Features

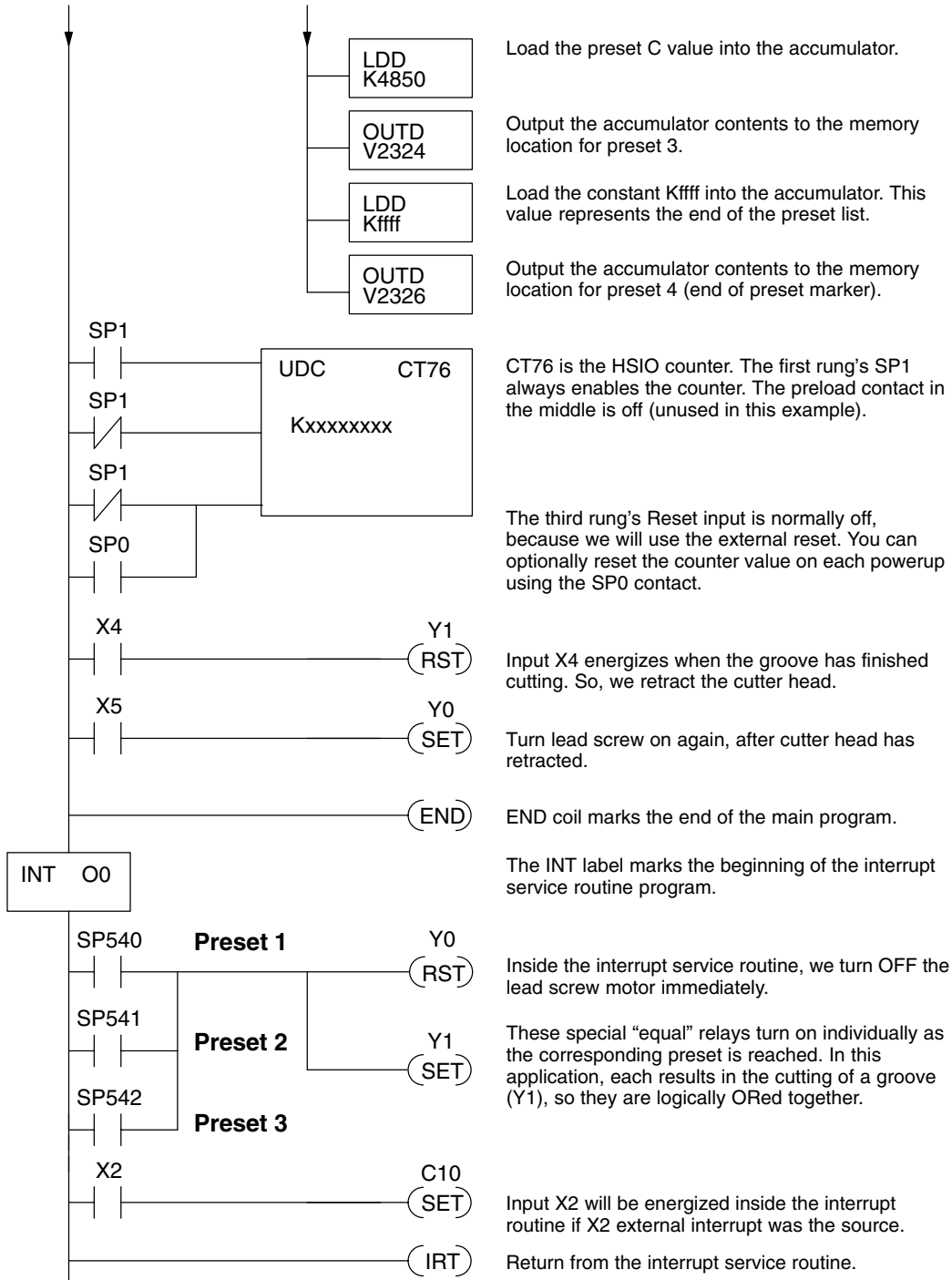

Some applications will require a different type of action at each preset. It is possible for the interrupt routine to distinguish one preset event from another, by turning on a unique output for each equal relay contact SPxxx. We can determine the source of the interrupt by examining the equal relay contacts individually, as well as X2. The X2 contact will be on (inside the interrupt routine only) if the interrupt was caused by the external reset, X2 input.

Counter With Preload Program Example

The following example shows how you can preload the current count with another value. When the preload command input (X4 in this example) is energized, we disable the counter from counting with C0. Then we write the value K3000 to the count register (V1076-V1077). By pulsing C1 on, we preload the current count of the counter with K3000. When the preload command (X4) is turned off, the counter resumes counting any pulses, but now starting from K3000.

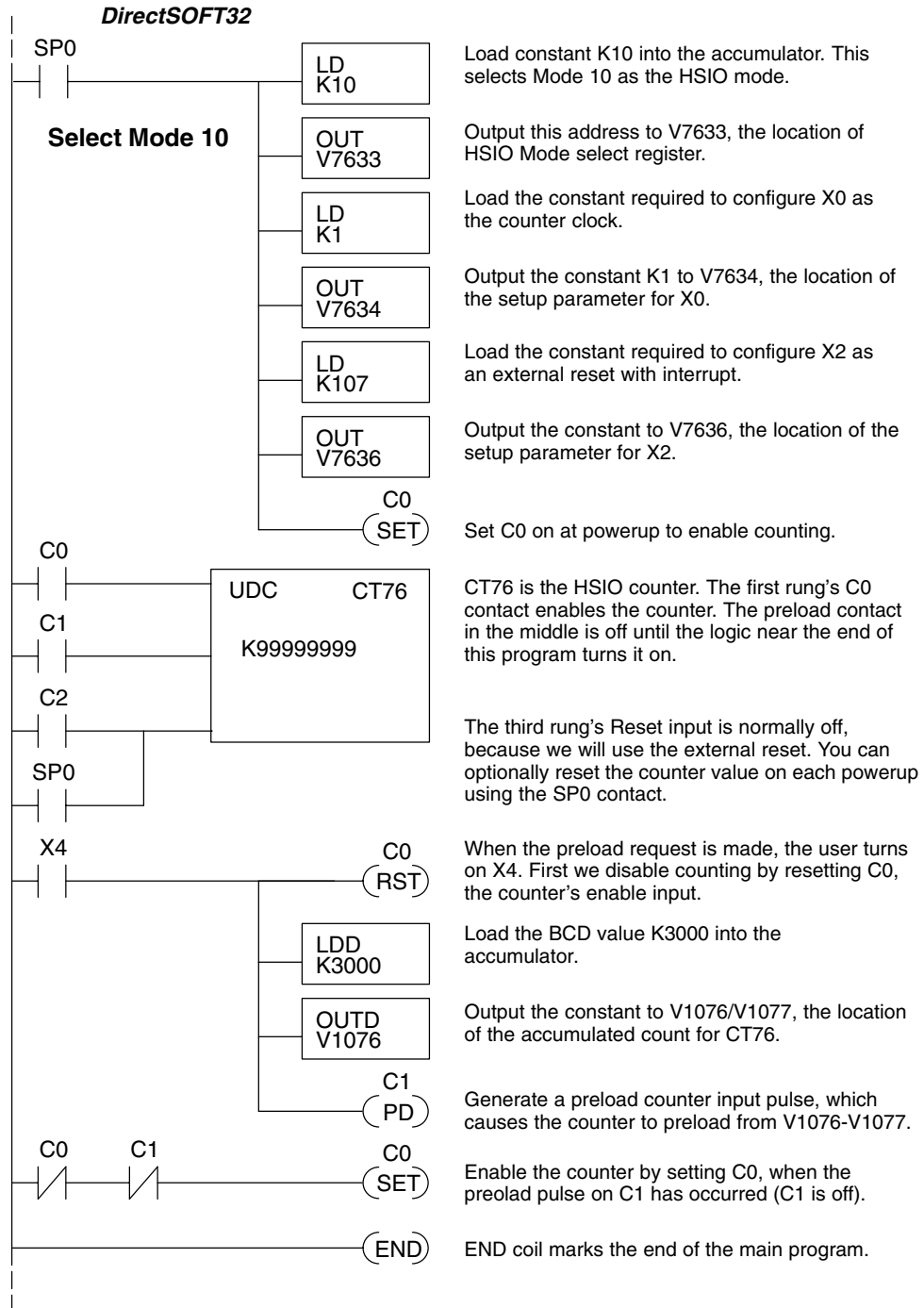

High-Speed Input and Pulse Output Features

Troubleshooting Guide for Mode 10 If you're having trouble with Mode 10 operation, please study the following symptoms and possible causes. The most common problems are listed below.

Symptom: The counter does not count.

Possible causes:

1. **Field sensor and wiring** – Verify that the encoder, proximity switch, or counter actually turns on and illuminates the status LED for X0. The problem could be due to sinking-sourcing wiring problem, etc. Remember to check the signal ground connection. Also verify that the pulse on-time is long enough for the PLC to recognize it.
2. **Configuration** – make sure all of the configuration parameters are correct. V7633 must be set to 10, and V7634 must be set to 1 to enable the HSIO counter mode.
3. **Stuck in reset** – check the input status of the reset input, X2. If X2 is on, the counter will not count because it is being held in reset.
4. **Ladder program** – make sure you are using counter CT76 in your program. The top input is the enable signal for the counter. It must be on before the counter will count. The middle input is the preload input and must be off for the counter to count. The bottom input is the counter reset, and must be off during counting.

Symptom: The counter counts but the presets do not function.

Possible causes:

1. **Configuration** – Ensure the preset values are correct. The presets are 32-bit BCD values having a range of 0 to 99999999. Make sure you write all 32 bits to the reserved locations by using the LDD and OUTD instructions. Use only even-numbered addresses, from V2320 to V2376. If using less than 24 presets, be sure to place "0000FFFF" in the location after the last preset used.
2. **Interrupt routine** – Only use Interrupt #0. Make sure the interrupt has been enabled by executing an ENI instruction prior to needing the interrupt. The interrupt routine must be placed after the main program, using the INT label and ending with an interrupt return IRT.
3. **Special relays** – Check the special relay numbers in your program. Use SP540 for Preset 1, SP541 for Preset 2, etc. Remember that only one special equal relay contact is on at a time. When the counter value reaches the next preset, the SP contact which is on now goes off and the next one turns on.

Symptom: The counter counts up but will not reset.

Possible causes:

1. Check the LED status indicator for X2 to make sure it is active when you want a reset. Or, if you are using an internal reset, use the status mode of **DirectSOFT32** to monitor the reset input to the counter.

Mode 20: Quadrature Counter

Purpose

The counter in the HSIO circuit can count two quadrature signal pulses instead of a single pulse train (mode 10 operation). Quadrature signals are commonly generated from incremental encoders, which may be rotary or linear. The quadrature counter has a range from 0 to 99999999, and can count at up to a 5 kHz rate, using CT76 and CT77. Unlike Mode 10 operation, the quadrature counter can count UP or DOWN, but *does not feature automated preset values or "interrupt on external reset" capability*. However, you have the standard ladder instruction preset of CT76.

Functional Block Diagram

The diagram below shows HSIO functionality in Mode 20. When the lower byte of HSIO Mode register V7633 contains a BCD "20", the quadrature counter in the HSIO circuit is enabled. Input X0 is dedicated to the Phase A quadrature signal, and input X1 receives Phase B signal. X2 is dedicated to reset the counter to zero value when energized. X3 can only be a regular filtered input in Mode 20.

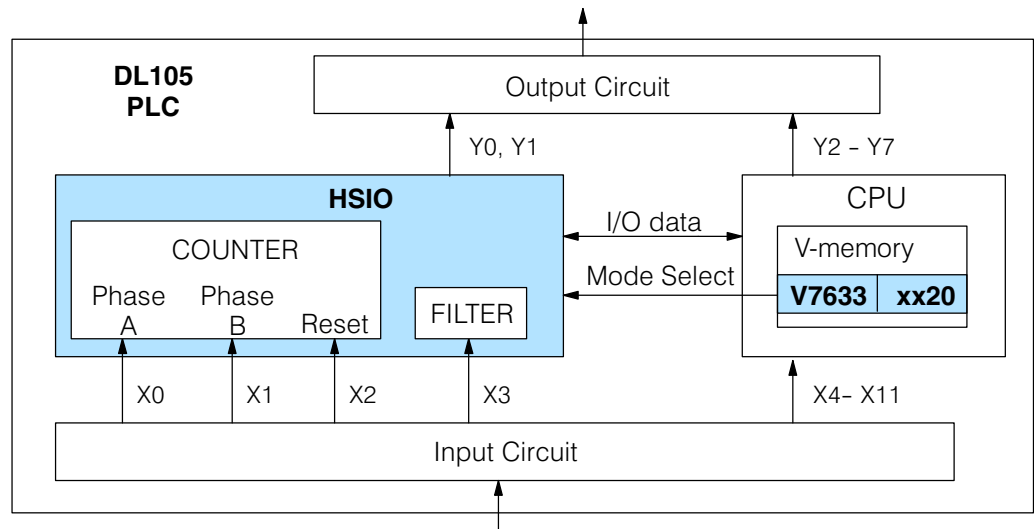

Quadrature Encoder Signals

Quadrature encoder signals contain position and direction information, while their frequency represents speed of motion. Phase A and B signals shown below are phase-shifted 90 degrees, thus the quadrature name. When the rising edge of Phase A precedes Phase B's leading edge (indicates clockwise motion by convention), the HSIO counter counts UP. If Phase B's rising edge precedes Phase A's rising edge (indicates counter-clockwise motion), the counter counts DOWN.

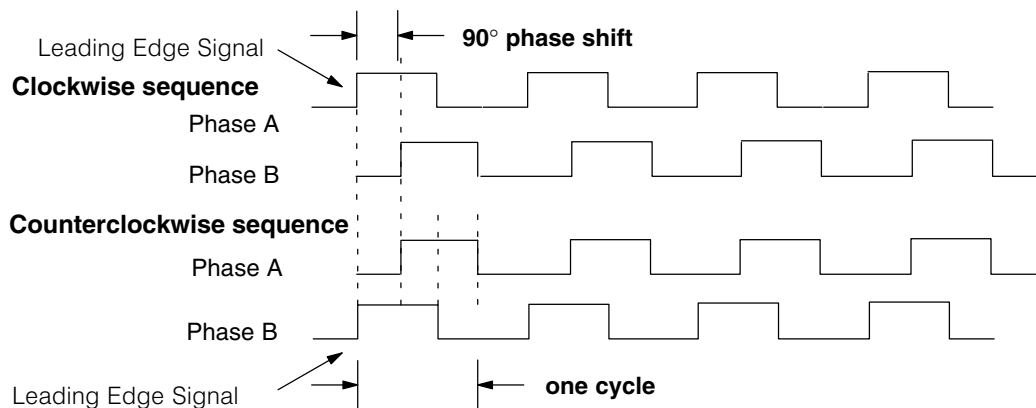

High-Speed Input and Pulse Output Features

Wiring Diagram

A general wiring diagram for encoders to the DL105 in HSIO Mode 20 is shown below. Encoders with sinking outputs (NPN open collector) are probably the best choice for interfacing. If the encoder sources to the inputs, it must output 12 to 24 VDC. Note that encoders with 5V sourcing outputs will not work with DL105 inputs.

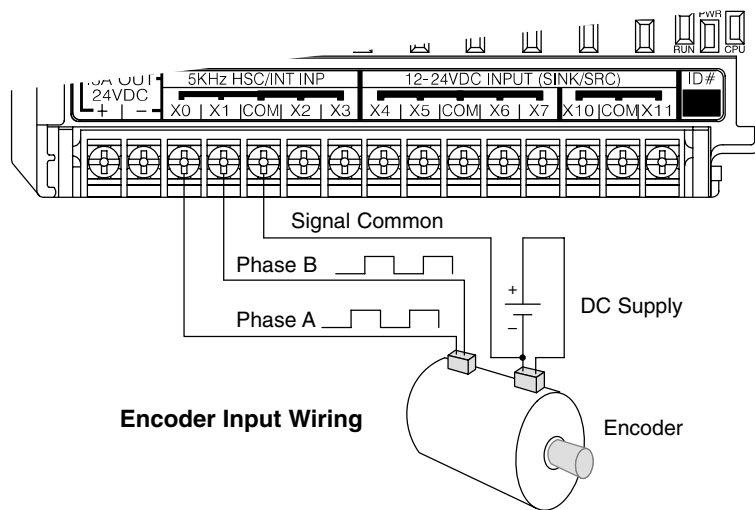

Encoder Input Wiring

Interfacing to Encoder Outputs

The DL105's DC inputs are flexible in that they detect current flow in either direction, so they can be wired to an encoder with either sourcing or sinking outputs. In the following circuit, an encoder has open-collector NPN transistor outputs. It sinks current from the PLC input point, which sources current. The power supply can be the +24VDC auxiliary supply or another supply (+12VDC or +24VDC), as long as the input specifications are met.

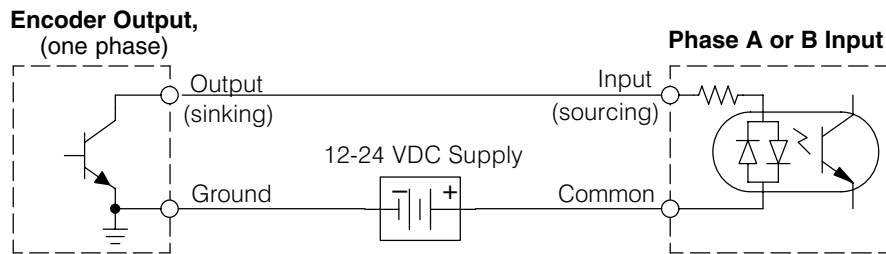

In the next circuit, an encoder has open-emitter PNP transistor outputs. It sources current to the PLC input point, which sinks the current back to ground. Since the encoder sources current, no additional power supply is required. However, note that the encoder output must be 12 to 24 volts (5V encoder outputs will not work).

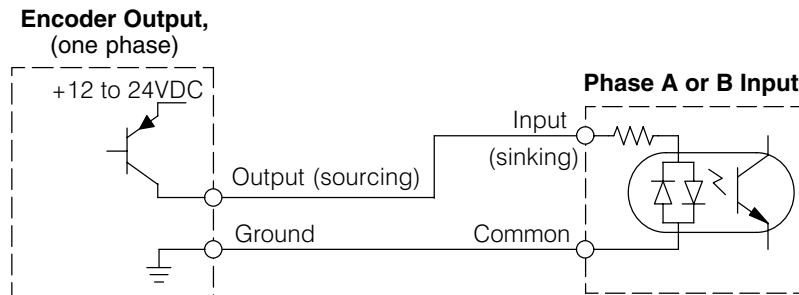

Setup for Mode 20 Recall that V7633 is the HSIO Mode Select register. Refer to the diagram below. Use BCD 20 in the lower byte to select High-Speed Counter Mode. Use BCD 00 or 20 in the upper byte as required. Combine the two bytes into a data word “xx20”, for writing to V7633.

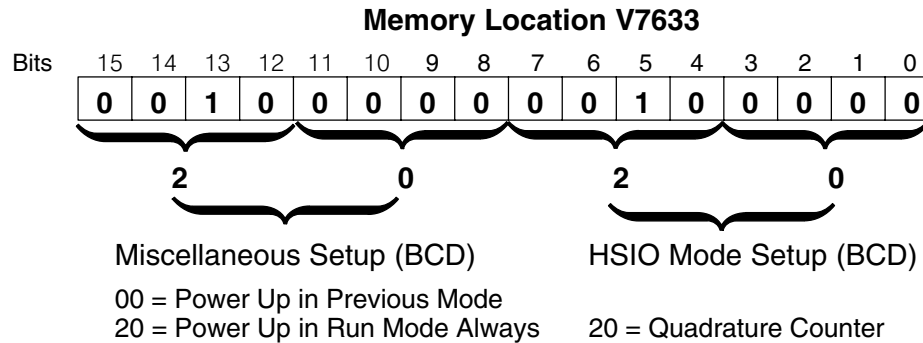

Choose the most convenient method of programming V7633 from the following:

- Include load and out instructions in your ladder program
- **DirectSOFT32's** memory editor
- Use the Handheld Programmer D2-HPP

We recommend using the first method above so that the HSIO setup becomes an integral part of your application program. An example program later in this section shows how to do this.

X Input Configuration

The configurable discrete input options for High-Speed Counter Mode are listed in the table below. Input X0 is dedicated for Phase A, and input X1 is for Phase B. Input X2 is the reset input to the quadrature counter, but it does not cause an interrupt. Input X3 can only be a filtered input. The section on Mode 60 operation at the end of this chapter describes programming the filter time constants.

Input	Configuration Register	Function	Hex Code Required
X0	V7634	Phase A	0012
X1	V7635	Phase B	0000
X2	V7636	Counter Reset (no interrupt)	0007
X3	V7637	Filtered Input	xx06 (xx = filter time)

Writing Your Control Program

You may recall that the Up-Down counter instruction is standard in the DL105 instruction set. Refer to the figure below. The mnemonic for the counter is **UDC** (up-down counter). The DL105 can have up to 64 counters, labeled CT0 through CT77. The quadrature counter in the HSIO circuit is accessed in ladder logic by using UDC CT76. It uses counter registers CT76 and CT77 exclusively when the HSIO mode 20 is active (otherwise, CT76 and CT77 are available for standard counter use). The HSIO counter needs two registers because it is a double-word counter. It also has three inputs as shown, but they are redefined. The first input is the enable signal, the middle is a preload (write), and the bottom is the reset. The enable input must be on before the counter will count. The preload input allows you to write a new value to the current count. The enable input must be off during a preload.

Standard Counter Function

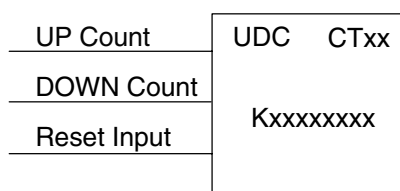

- Counts UP and DOWN
- Preload counter by write to value
- Reset input is internal only

HSIO Counter Function

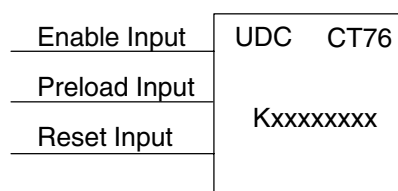

- Counts UP and DOWN (from X0, X1)
- Can use Preload input to change count
- Reset may be internal or external

The next figure shows the how the HSIO quadrature counter will appear in a ladder program.

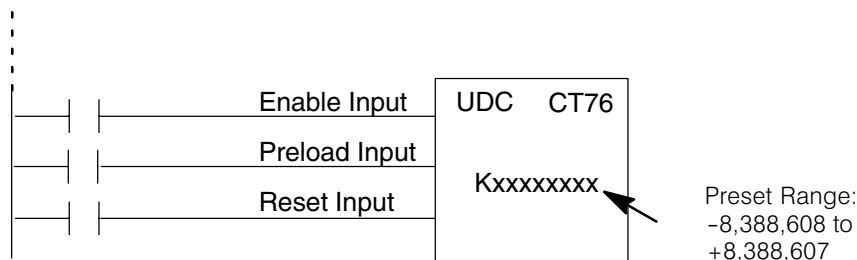

When the enable input is energized, the counter will respond to quadrature pulses on X0 and X1, incrementing or decrementing the counter at CT76 – CT77. The reset input contact behaves in a logical OR fashion with the physical reset input X2. This means the quadrature counter can receive a reset from either the contact(s) on the reset rung in the ladder, OR the external reset X2.

Quadrature Counter w/Preload Program Example

Since presets are not available in quadrature counting, this mode is best suited for simple counting and measuring. The example program on the following page shows how to configure the quadrature counter. The program configures the HSIO circuit for Mode 20 operation, so X0 is Phase A and X1 is Phase B clock inputs.

High-Speed Input and Pulse Output Features

Program Example Cont'd

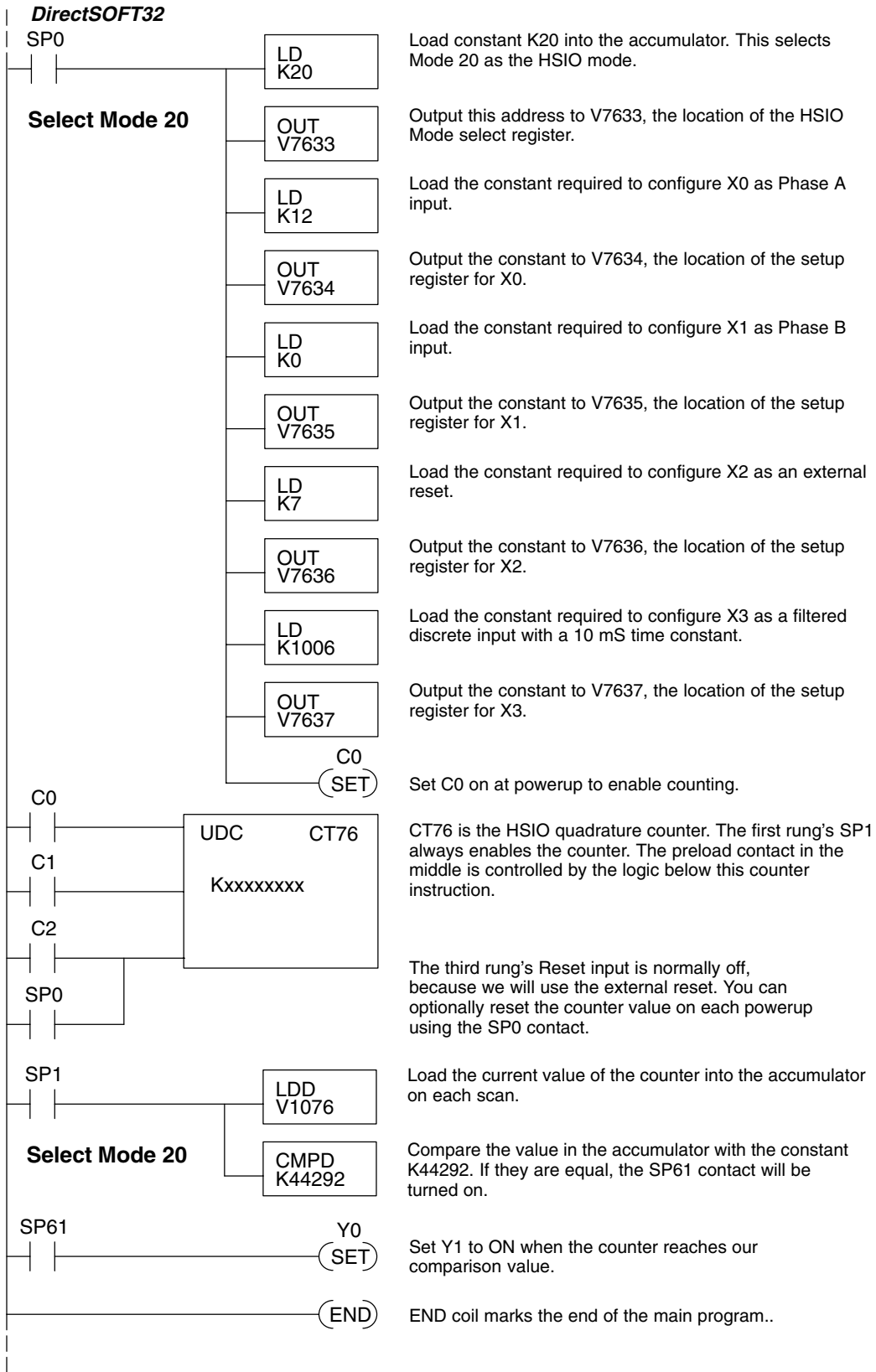

High-Speed Input and Pulse Output Features

To preload the counter, just add the following example rungs to the program above.

Counter Preload Program Example

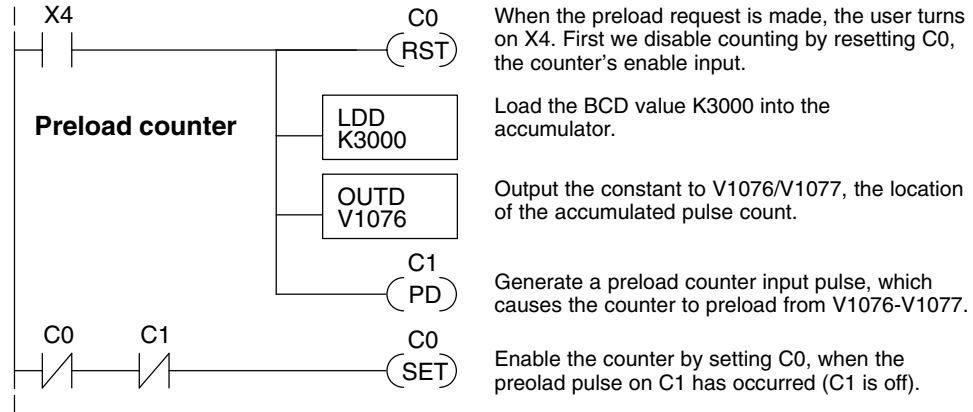

When the preload request is made, the user turns on X4. First we disable counting by resetting C0, the counter's enable input.

Load the BCD value K3000 into the accumulator.

Output the constant to V1076/V1077, the location of the accumulated pulse count.

Generate a preload counter input pulse, which causes the counter to preload from V1076-V1077.

Enable the counter by setting C0, when the preload pulse on C1 has occurred (C1 is off).

Troubleshooting Guide for Mode 20 If you're having trouble with Mode 20 operation, please study the following symptoms and possible causes. The most common problems are listed below.

Symptom: The counter does not count.

Possible causes:

1. **Field sensor and wiring** – Verify that the encoder or other field device inputs actually turn on and illuminates the status LEDs for X0 and X1. A standard incremental encoder will visibly, alternately turn on the LEDs for X0 and X1 when rotating slowly (1 RPM). Or, the problem could be due to a sinking-sourcing wiring problem, etc. Remember to check the signal ground connection. Also verify that the pulse on-time, duty cycle, voltage level, and frequency are within the input specifications.
2. **Configuration** – make sure all of the configuration parameters are correct. V7633 must be set to 20, and V7634 must be set to "0012" to enable the Phase A input, and V7635 must be set to "0000" to enable the Phase B input.
3. **Stuck in reset** – check the input status of the reset input, X2. If X2 is on, the counter will not count because it is being held in reset.
4. **Ladder program** – make sure you are using counter CT76 in your program. The top input is the enable signal for the counter. It must be on before the counter will count. The middle input is the preload input and must be off for the counter to count. The bottom input is the counter reset, and must be off during counting.

Symptom: The counter counts in the wrong direction (up instead of down, and visa-versa).

Possible causes:

1. **Channel A and B assignment** – It's possible that Channel A and B assignments of the encoder wires is backwards from the desired rotation/counting orientation. Just swap the X0 and X1 inputs, and the counting direction will be reversed.

Symptom: The counter counts up and down but will not reset.

Possible causes:

1. Check the LED status indicator for X2 to make sure it is active when you want a reset. Also verify the configuration register V7636 for X2 is set to 7. Or, if you are using an internal reset, use the status mode of **DirectSOFT32** to monitor the reset input to the counter.

Mode 30: Pulse Output

Purpose

The HSIO circuit in Mode 30 generates output pulse trains suitable for open-loop control of a single-axis motion positioning system. It generates pulse (stepper increment) and direction signals which you can connect to motor drive systems and perform various types of motion control. Using Mode 30 Pulse Output, you can select from three profile types:

- **Trapezoidal** – Accel Slope to Target Velocity to Decel Slope
- **Registration** – Velocity to Position Control on Interrupt (also used for home search moves)
- **Velocity Control** – Speed and Direction only

The HSIO circuit becomes a high-speed pulse generator (up to 7 kHz) in Mode 30. By programming acceleration and deceleration values, position and velocity target values, the HSIO function automatically calculates the entire motion profile. The figure below shows the DL105 generating pulse and direction signals to the drive amplifier of a stepper positioning system. The pulses accomplish the profile independently and without interruption to ladder program execution in the CPU.

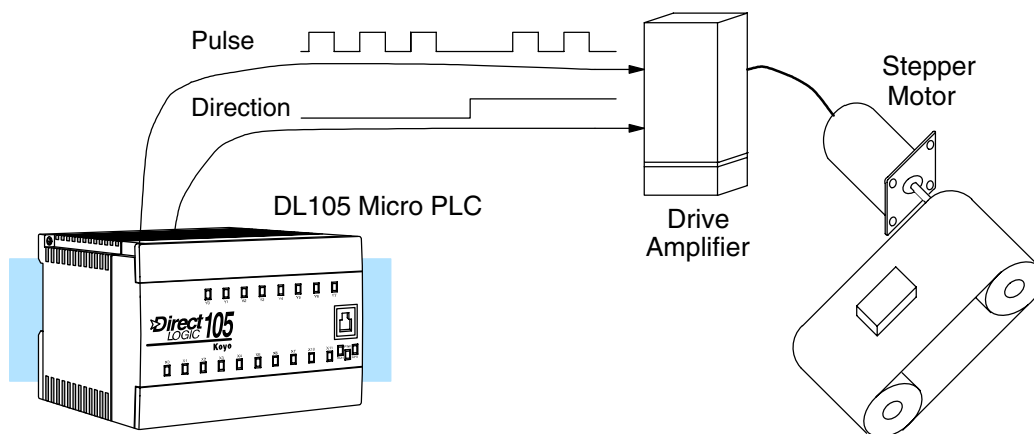

In the figure above, the DL105 generates pulse and direction signals. Each pulse represents the smallest increment of motion to the positioning system (such as one step or micro-step to a stepper system). Alternatively, the HSIO Pulse Output Mode may be configured to deliver counter clock-wise (CCW) and clock-wise (CW) pulse signals as shown to the right.

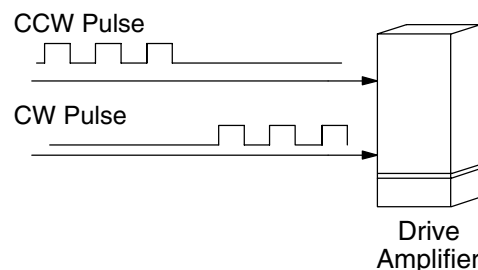

NOTE: The pulse output is designed for open loop stepper motor systems. This, plus its minimum velocity of 40 pps make it unsuitable for servo motor control.

Functional Block Diagram

The diagram below shows HSIO functionality in Mode 30. When the lower byte of HSIO Mode register V7633 contains a BCD “30”, the pulse output capability in the HSIO circuit is enabled. The pulse outputs use Y0 and Y1 terminals on the output connector. Remember that the outputs can only be DC type to operate.

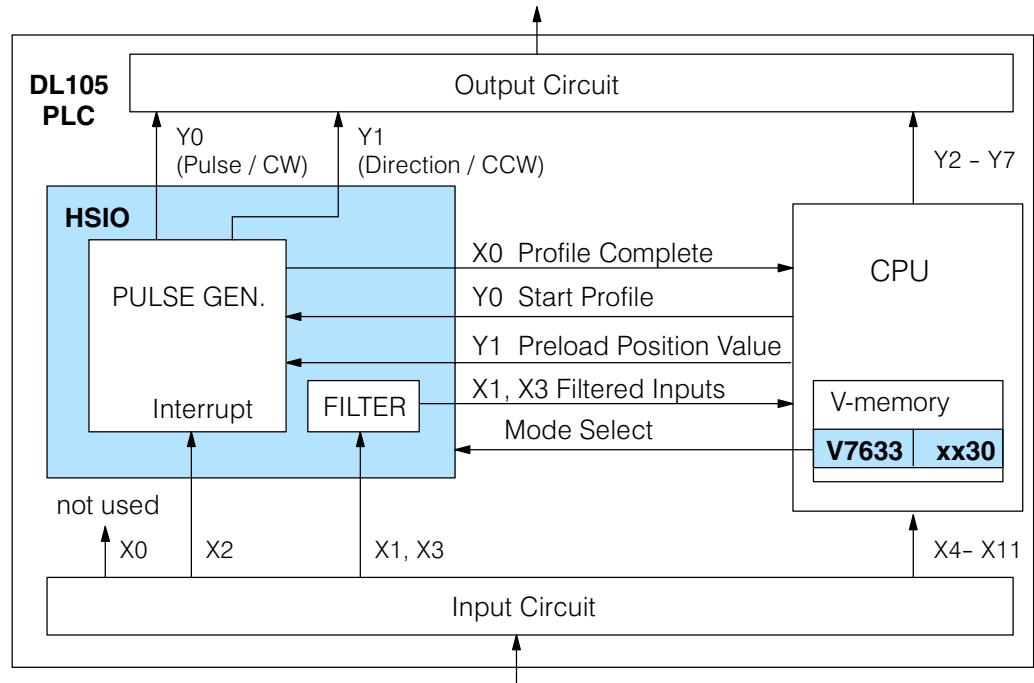

IMPORTANT NOTE: In Pulse Output Mode, X0, Y0, and Y1 references are redefined or are used differently in two ways. *Physical* references refer to terminal screws, while *logical* references refer to I/O references in the ladder program. Please read the items below to understand this very crucial point.

Notice the I/O point assignment and usage in the above diagram:

- Physical input X0 is not used, so the terminal screw will not be wired. However, the HSIO function uses logical reference X0 for “Profile Complete” contact, which is available for ladder program use.
- X1 and X3 can only be filtered inputs in Pulse Output Mode, and they are available as input contacts to the ladder program.
- X2 behaves as an external interrupt to the pulse generator for registration profiles. In other profile modes, it can be used as a filtered input just like X1 and X3 (registration mode configuration shown above).
- References “Y0” and “Y1” are used in two different ways. At the output connector, Y0 and Y1 terminals deliver the pulses to the motion system. The ladder program uses logical references Y0 and Y1 to initiate “Start Profile” and “Load Position Value” HSIO functions in Mode 30.

Hopefully, the above discussion will explain why some I/O reference names have dual meanings in Pulse Output Mode. **Please read the remainder of this section with care**, to avoid confusion about which actual I/O function is being discussed.



Wiring Diagram

The generalized wiring diagram below shows pulse outputs Y0 and Y1 connected to the drive amplifier inputs of a motion control system.

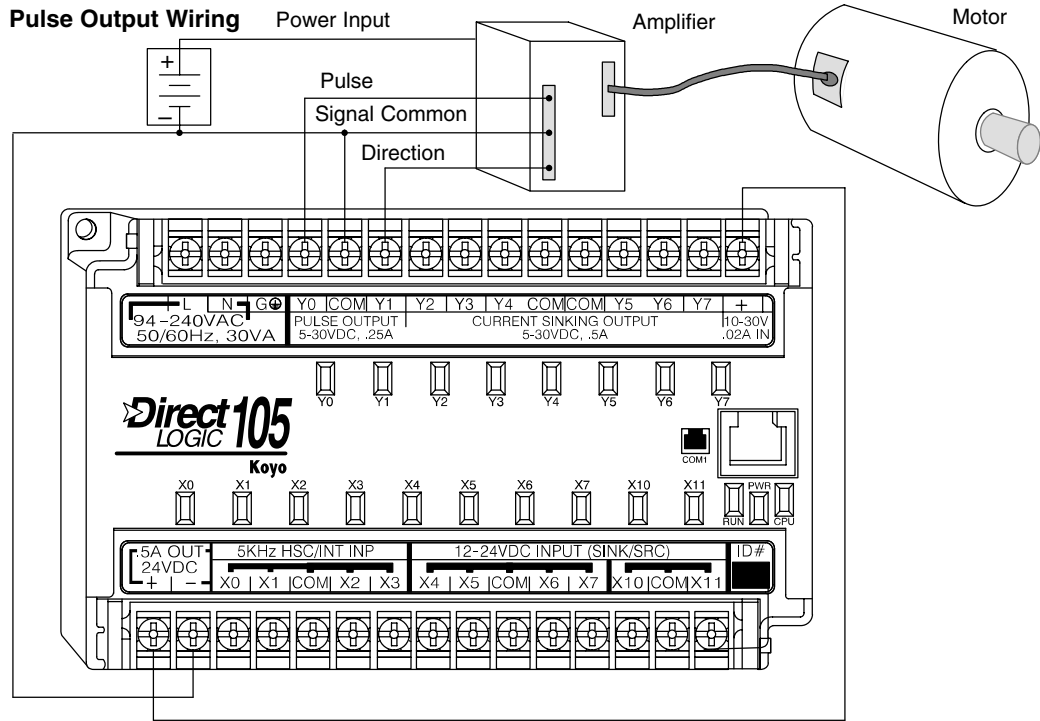

Interfacing to Drive Inputs

The pulse signals from Y0 and Y1 outputs will typically go to drive input circuits as shown above. Remember that the DL105's DC outputs are sinking-only. It will be helpful to locate equivalent circuit schematics of the drive amplifier. The following diagram shows how to interface to a sourcing drive input circuit.

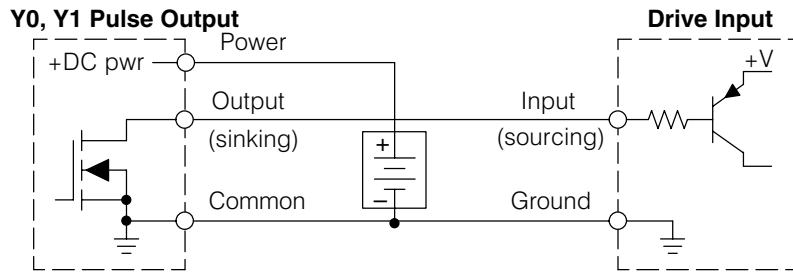

The following circuit shows how to interface to a sinking drive input using a pullup resistor. Please refer to Chapter 2 to learn how to calculate and install R_{pullup} .

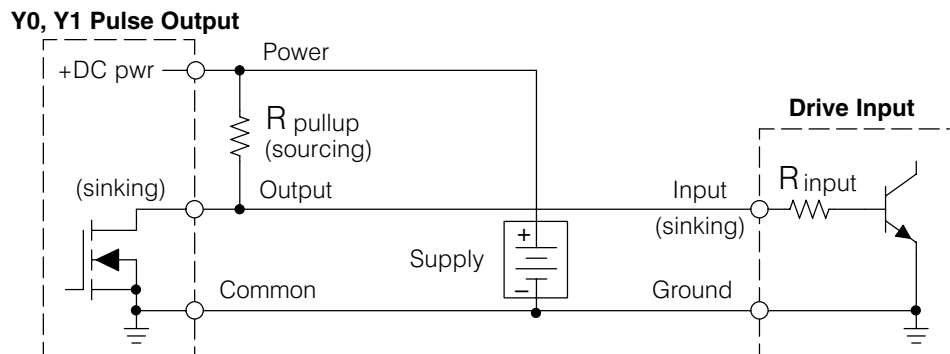

High-Speed Input and Pulse Output Features

Motion Profile Specifications

The motion control profiles generated in Pulse Output Mode have the following specifications:

Parameter	Specification
Profiles	Trapezoidal – Accel Slope / Target Velocity / Decel Slope
	Registration – Velocity to Position Control on Interrupt
	Velocity Control – Speed and Direction only
Position Range	–88388608 to 88388607
Positioning	Absolute / relative command
Velocity Range	40 Hz to 7 kHz
V-memory registers	V2320 to V2325 (Profile Parameter Table)
Current Position	CT76 and CT77 (V1076 and V1077)

Physical I/O Configuration

The configurable discrete I/O options for Pulse Output Mode are listed in the table below. Physical input X0 is not available, because the CPU uses logical X0 contact to sense “profile complete”. Therefore, V7634 is put to another use: selecting pulse/direction or CCW/CW modes for the pulse outputs. Inputs X1 and X3 can only be filtered inputs. Input X2 is dedicated as the external interrupt for use in registration mode.

Physical Input	Configuration Register	Function	Hex Code Required
–	V7634	Y0 = Pulse Y1 = Direction	0103
		Y0 = CW Pulse Y1 = CCW Pulse	0003
X1	V7635	Filtered Input	xx06 (xx = filter time)
X2	V7636	External Interrupt	1006
X3	V7637	Filtered Input	xx06 (xx = filter time)

Logical I/O Functions

The following logical I/O references define functions that allow the HSIO to communicate with the ladder program.

Logical I/O	Function
X0	Profile Complete – the HSIO turns on X0 to the CPU when the profile completes. Goes back off when Start Profile (Y0) turns on.
Y0	Start Profile – the ladder program turns on Y0 to start motion. If turned off before the move completes, motion stops. Turning it on again will start another profile, unless the current position equals the target position.
Y1	Preload Position Value – if motion is stopped and Start Profile is off, you can load a new value in CT76/CT77, and turn on Y1. At that transition, the value in CT76/CT77 becomes the current position.

Setup for Mode 30 Recall that V7633 is the HSIO Mode Select register. Refer to the diagram below. Use BCD 30 in the lower byte to select Pulse Output Mode. Use BCD 00 or 20 in the upper byte as required. Combine the two bytes into a data word “xx30”, for writing to V7633.

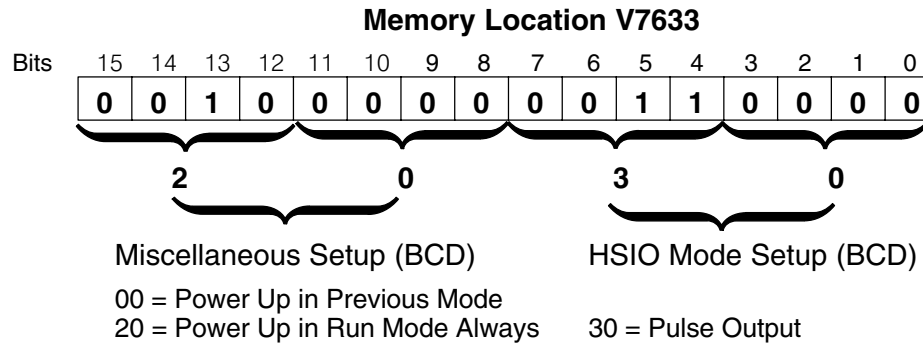

Choose the most convenient method of programming V7633 from the following:

- Include load and out instructions in your ladder program
- **DirectSOFT32's** memory editor
- Use the Handheld Programmer D2-HPP

We recommend using the first method above so that the HSIO setup becomes an integral part of your application program. An example program later in this section shows how to do this.

Profile / Velocity Select Register

The first location in the Profile Parameter Table stores two key pieces of information. The upper four bits (12–15) select the type of profile required. The lower 12 bits (0–11) select the Target Velocity.

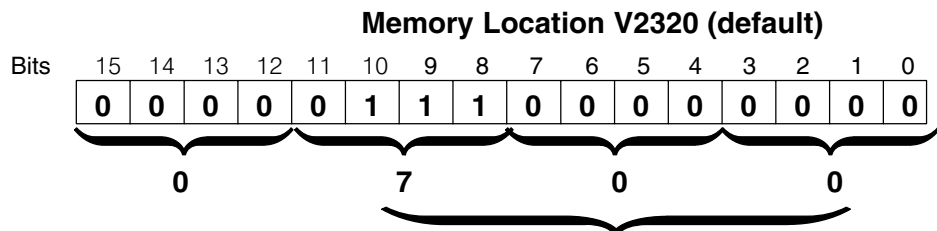

The ladder program must program this location before initiating any of the three profiles. The LD and OUT instruction will write all 16 bits, so be sure to fully specify the full four-digit BCD value for the Position / Velocity Select Register each time.

The absolute and relative selection determines how the HSIO circuit will interpret your specified target position. Absolute position targets are referenced to zero. Relative position targets are referenced to the current position (previous target position). You may choose whichever reference method that is most convenient for your application.

High-Speed Input and Pulse Output Features

Profile Parameter Table

V7630 is a pointer location which points to the beginning of the Profile Parameter Table. The default starting location for the profile parameter table is V2320. However, you may change this by programming a different value in V7630. Remember to use the LDA (load address) instruction, converting octal into hex.

The HSIO uses the next V-memory register past the bottom of the profile parameter table to indicate profile errors. See the error table at the end of this section for error code definitions.

Profile Table Pointer

V7630	2320
-------	------

Profile Parameter Table

V2320	xxxx	
V2321	xxxx	xxxx
V2323	xxxx	
V2324	xxxx	
V2325	xxxx	

Pulse Output Error Code

V2326	00xx
-------	------

Trapezoidal Profile

V-Memory	Function	Range	Units
V2320, bits 12–15	Trapezoidal Profile	0=absolute, 8=relative	–
V2320, bits 0–11	Target Velocity Value	4 to 700	x 10 pps
V2321/ 2322	Target Position Value	–88388608 to 88388607	Pulses
V2323	Starting Velocity	4 to 100	x 10 pps
V2324	Acceleration Time	1 to 100	x 100 mS
V2325	Deceleration Time	1 to 100	x 100 mS
V2326	Error Code	(see end of section)	–

Registration Profile

V-Memory	Function	Range	Units
V2320, bits 12–15	Registration Profile	9=relative	–
V2320, bits 0–11	Target Velocity Value	4 to 700	x 10 pps
V2321/ 2322	Target Position Value	–88388608 to 88388607	Pulses
V2323	Starting Velocity	4 to 100	x 10 pps
V2324	Acceleration Time	1 to 100	x 100 mS
V2325	Deceleration Time	1 to 100	x 100 mS
V2326	Error Code	(see end of section)	–

Velocity Profile

V-Memory	Function	Range	Units
V2320	Velocity Profile	2000 only	–
V2321/ 2322	Direction Select	80000000=CCW, 0=CW	Pulses
V2323	Velocity	4 to 700	x 10 pps
V2326	Error Code	(see end of section)	–

Choosing the Profile Type

Pulse Output Mode generates three types of motion profiles. Most applications use one type for most moves. However, each move can be different if required.

- Trapezoidal – Accel Slope to Target Velocity to Decel Slope
- Registration – Velocity to Position Control on Interrupt
- Velocity Control – Speed and Direction only

Trapezoidal Profile Defined

The trapezoidal profile is the most common positioning profile. It moves the load to a pre-defined target position by creating a move profile. The acceleration slope is applied at the starting position. The deceleration slope is applied backwards from the target position. The remainder of the move in the middle is spent traveling at a defined velocity.

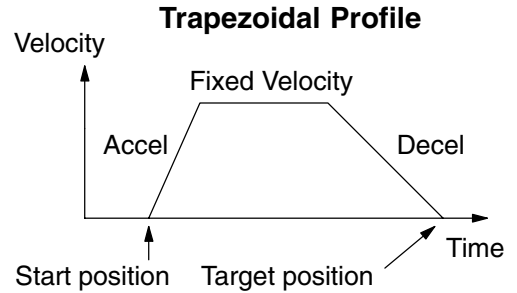

Trapezoidal profiles are best for simple point-to-point moves, when the distance between the starting and ending positions of the move is known in advance.

Registration and Home Search Profiles Defined

Registration profiles solve a class of motion control problems. In some applications, product material in work moves past a work tool such as a drill station. Shown to the right, registration marks on the scrap area of the work-piece allow a machine tool to register its position relative to the rectangle, to drill properly.

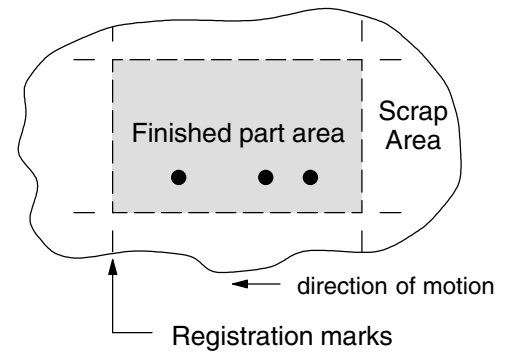

Home search moves allow open-loop motion systems to re-calibrate (preload) the current position value at powerup.

Registration profiles are a combination of velocity and position control modes. The move begins by accelerating to a programmed velocity. The velocity is sustained and the move is of indefinite duration. When an external interrupt signal occurs (due to registration sensing), the profile switches from velocity to position control. The move ends by continuing motion a pre-defined distance past the interrupt point (such as a drill hole location). The deceleration ramp is applied in advance of the target position.

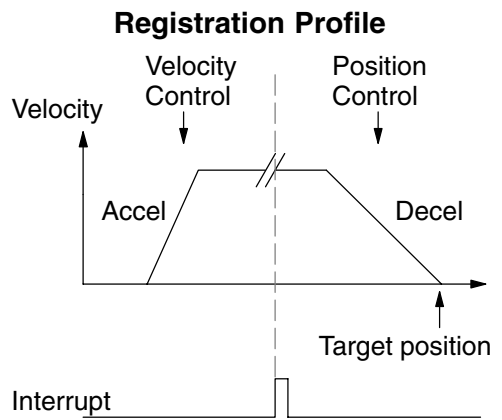

Velocity Profile Defined

The velocity profile controls only the direction and speed of motion. There is no target position specified, so the move can be of indefinite length. Only the first velocity value needs to be defined. The remaining velocity values can be created while motion is in progress. Arrows in the profile shown indicate velocity changes.

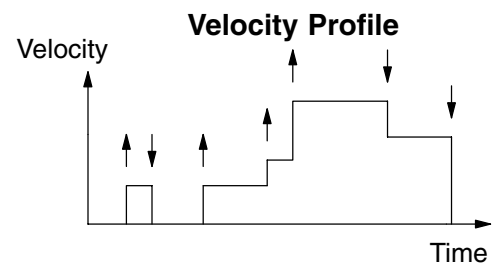

High-Speed Input and Pulse Output Features

Trapezoidal Profile Operation

Trapezoidal Profile Applications

The trapezoidal profile is best suited for simple point-to-point moves, when the target position is known in advance. Starting velocities must be within the range of 40 pps to 1 kpps. The remainder of the profile parameters are in the profile parameter table.

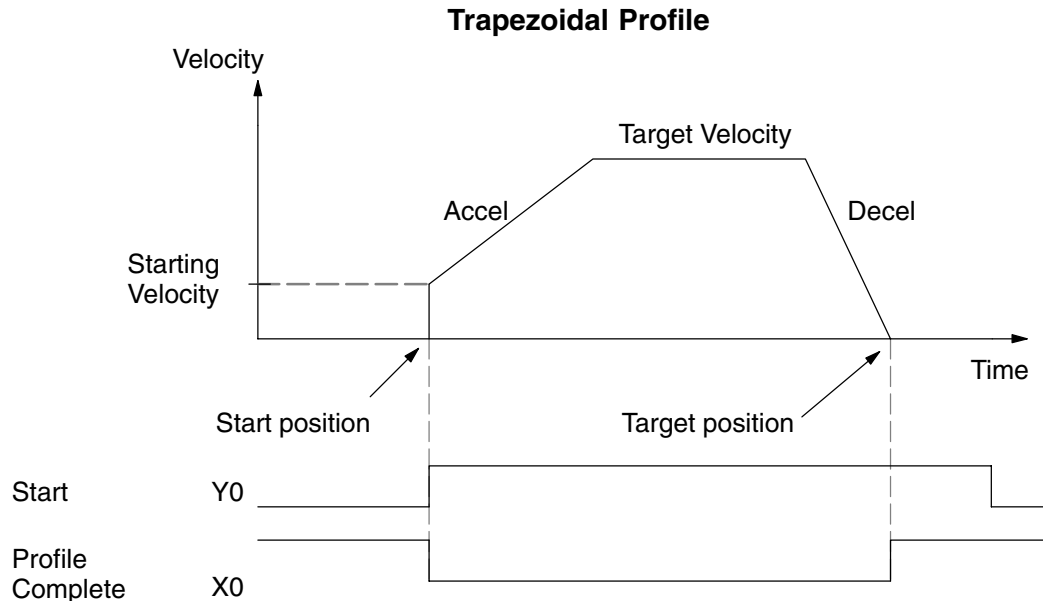

The time line of signal traces below the profile indicates the order of events.

The HSIO uses logical output Y0 as the Start input to the HSIO, which starts the profile. Immediately the HSIO turns off the Profile Complete signal (logical X0), so the ladder program can monitor the progress of the move. Typically a ladder program will monitor this bit so it knows when to initiate the next profile move.

If you are familiar with motion control, you'll notice that we do not have to specify the direction of the move. The HSIO function examines the target position relative to the current position, and automatically outputs the correct direction information to the motor drive.

Notice that the motion accelerates immediately to the starting velocity. This segment is useful in stepper systems so we can jump past low speed areas when low-torque problems or a resonant point in the motor might cause a stall. (When a stepper motor stalls, we have lost the position of the load in open-loop positioning systems). However, it is preferable not to make the starting velocity too large, because the stepper motor will also "slip" some pulses due to the inertia of the system.

When you need to change the current position value, use logical Y1 output coil to load a new value into the HSIO counter. If the ladder program loads a new value in CT76/CT77 (V1076/V1077), then energizing Y1 will copy that value into the HSIO circuit counter. This must occur before the profile begins, because the HSIO ignores Y1 during motion.

Trapezoidal Profile Program Example The trapezoidal profile we want to perform is drawn and labeled in the following figure. It consists of a non-zero starting velocity, and moderate target velocity.

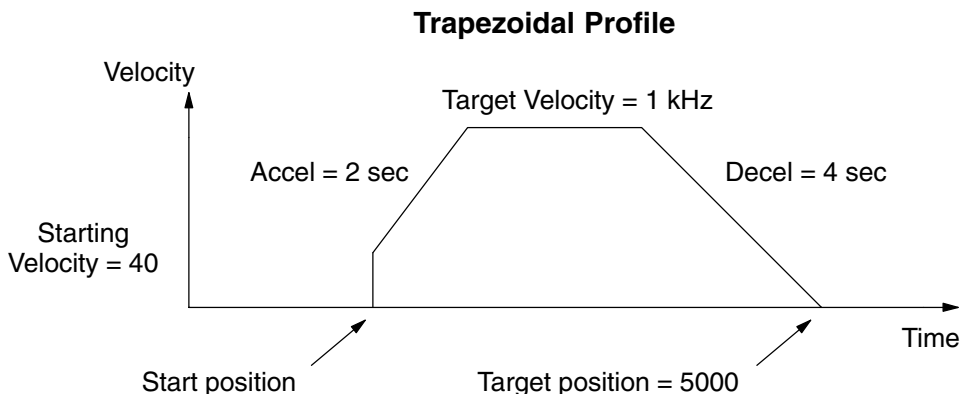

The following program will realize the profile drawn above, when executed. The beginning of the program contains all the necessary setup parameters for Pulse Output Mode 30. We only have to do this once in the program, so we use first-scan contact SP0 to trigger the setup.

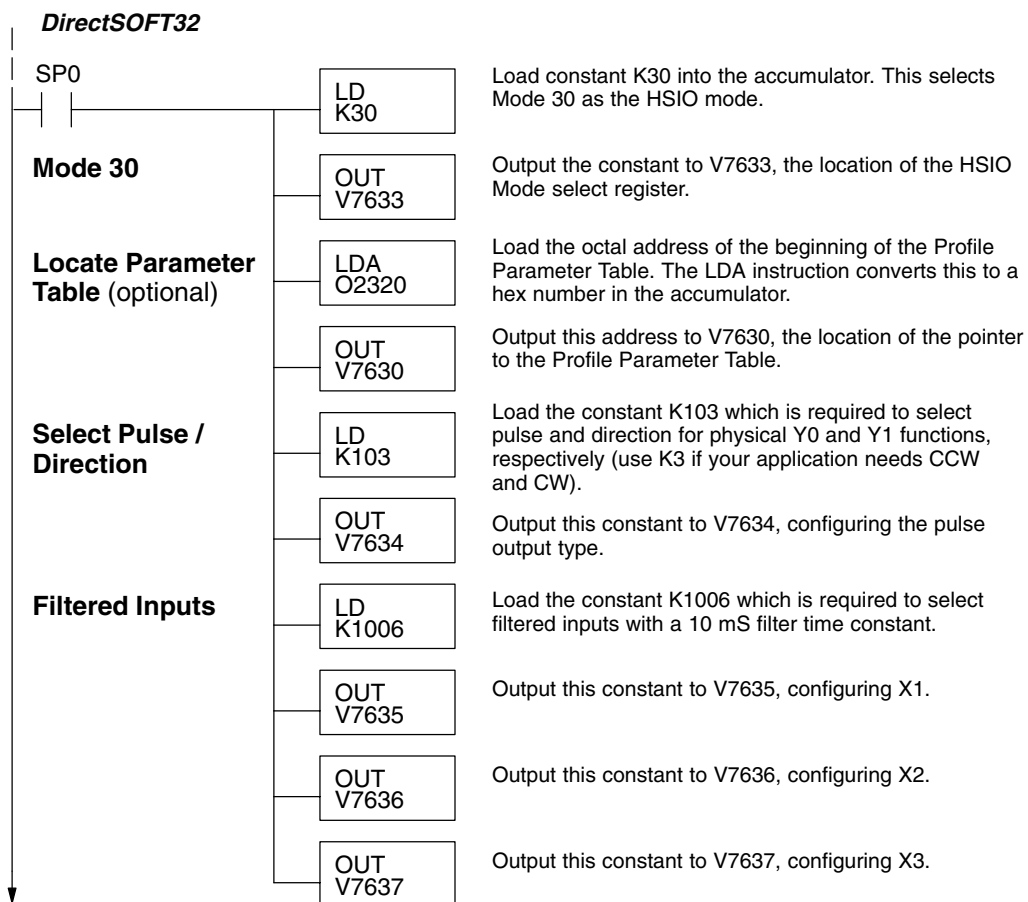

High-Speed Input and Pulse Output Features

Program Example Cont'd

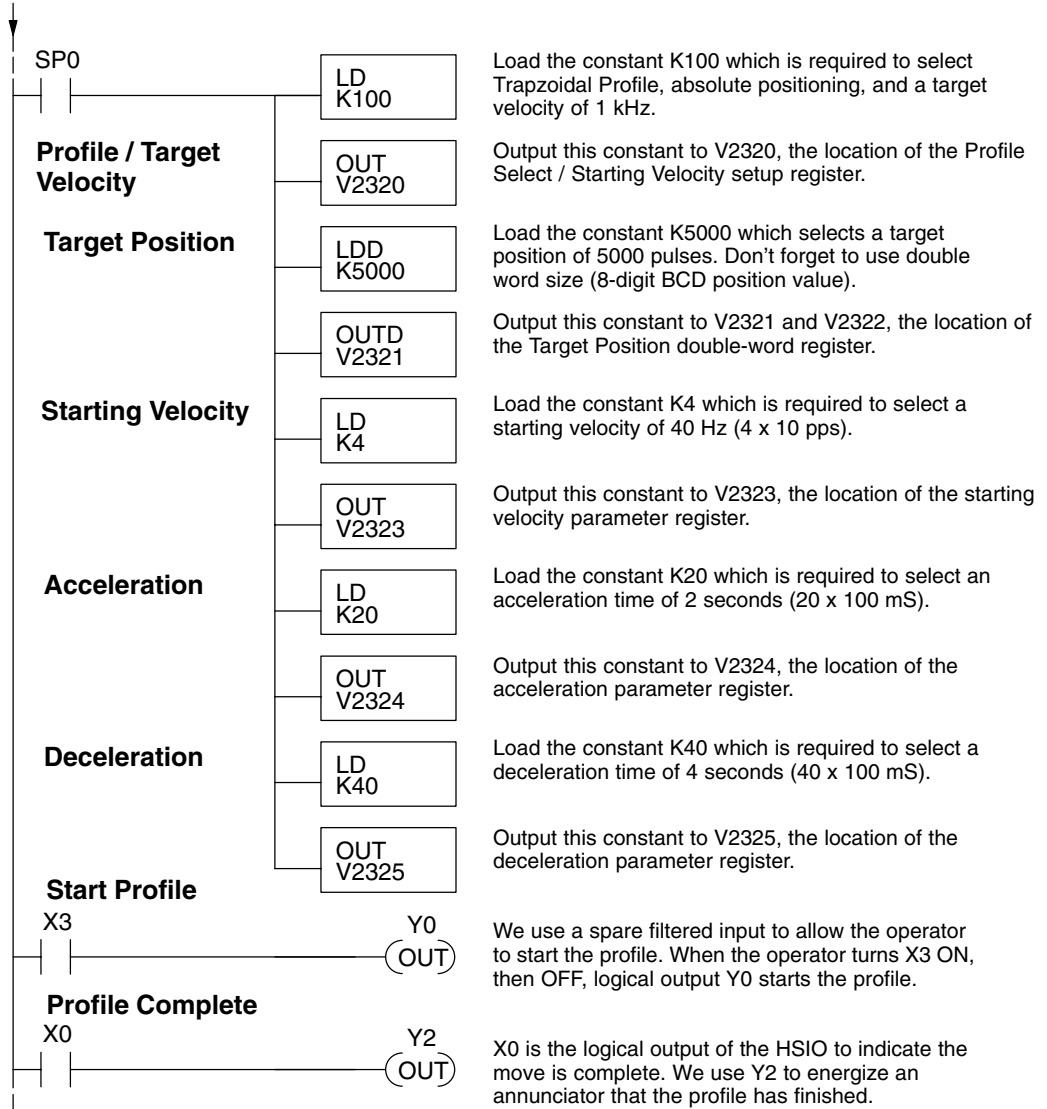

Preload Position Value

At any time you can write (preload) a new position into the current position value. This is often done after a home search (see the registration example programs).

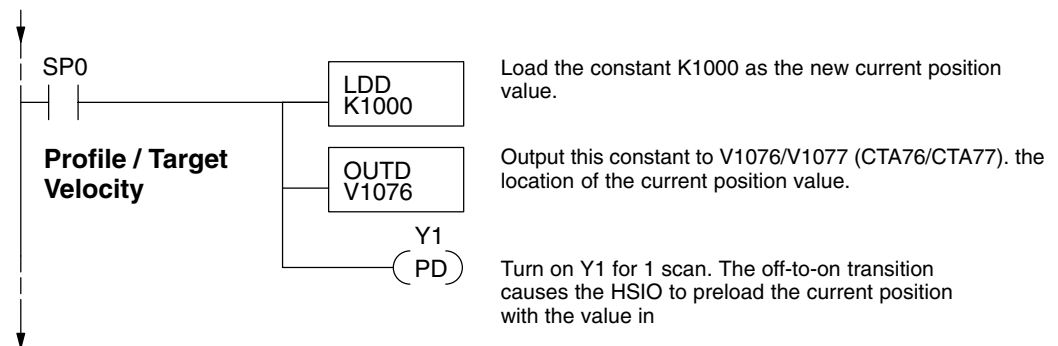

Registration Profile Operation

Registration Applications

1. In a typical application shown to the right, product material in work moves past a work tool such as a drill. Registration marks on the scrap area of the work-piece allow a machine tool to register its position relative to the rectangle, to drill properly.

2. In other examples of registration, the work piece is stationary and the tool moves. A drill bit may approach the surface of a part in work, preparing to drill a hole of precise depth. However, the drill bit length gradually decreases due to tool wear. A method to overcome this is to detect the moment of contact with the part surface on each drill, moving the bit into the part a constant distance after contact.

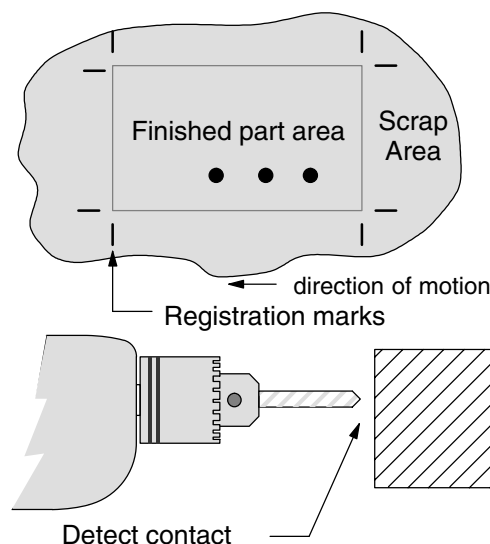

3. The home search move allows a motion system to calibrate its position on startup. In this case, the positioning system makes an indefinite move and waits for the load to pass by a home limit switch. This creates an interrupt at the moment when the load is in a known position. We then stop motion and preload the position value with a number which equates to the physical “home position”.

The registration profile begins with only velocity control. When an interrupt pulse occurs on physical input X2, the starting position is declared to be the present count (current load position). The velocity control switches to position control, moving the load to the target position. Note that the minimum starting velocity is 40 pps. This instantaneous velocity accommodates stepper motors that can stall at low speeds.

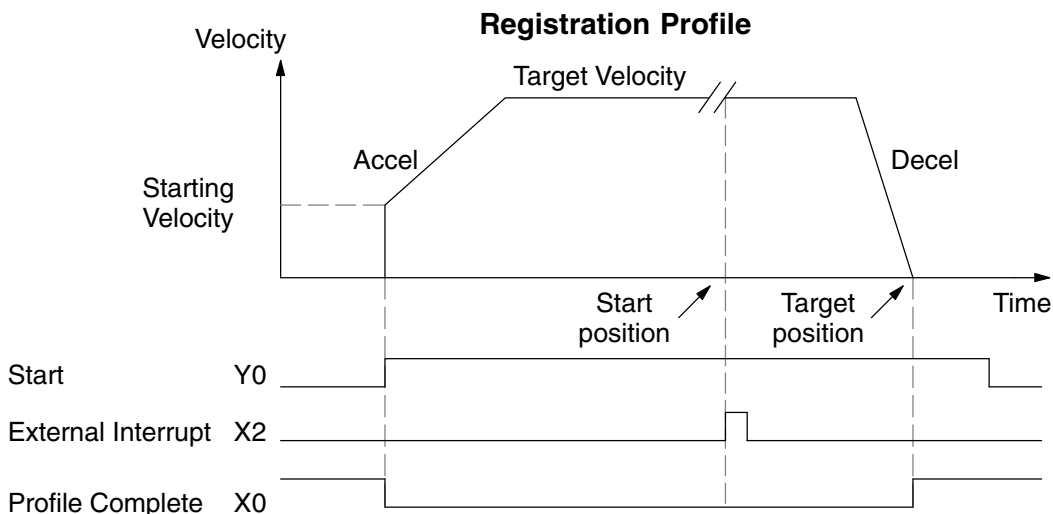

The time line of signal traces below the profile indicates the order of events. The CPU uses logical output Y0 to start the profile. Immediately the HSIO turns off the Profile Complete signal (logical X0), so the ladder program can monitor the move's completion by sensing the signal's on state.

Registration Profile Program Example The registration profile we want to perform is drawn and labeled in the following figure. It consists of a non-zero starting velocity, and moderate target velocity.

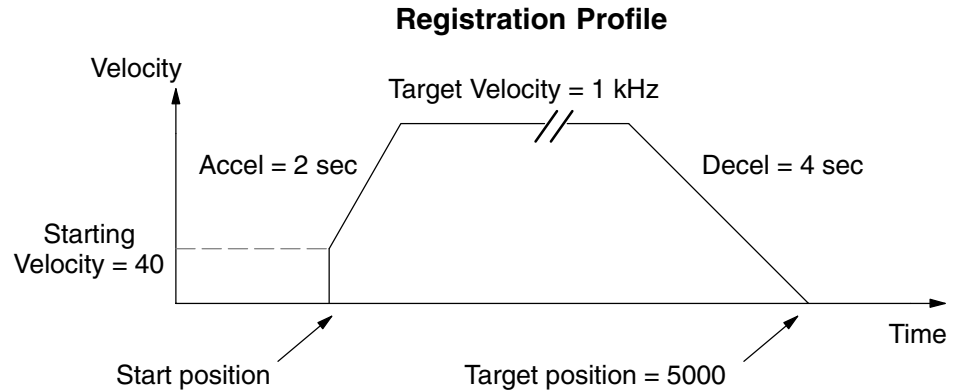

The following program will realize the profile drawn above, when executed. The first program rung contains all the necessary setup parameters. We only have to do this once in the program, so we use first-scan contact SP0 to trigger the setup.

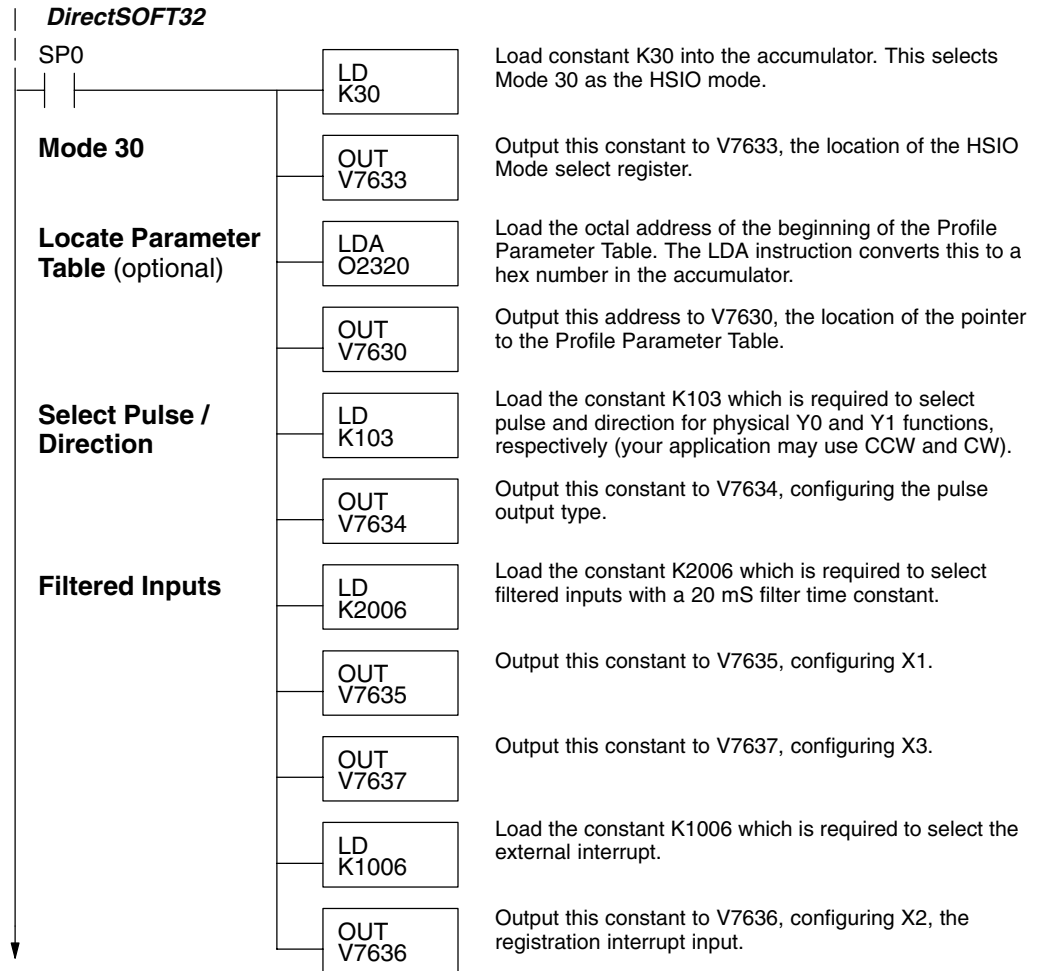

High-Speed Input and Pulse Output Features

Program Example Cont'd

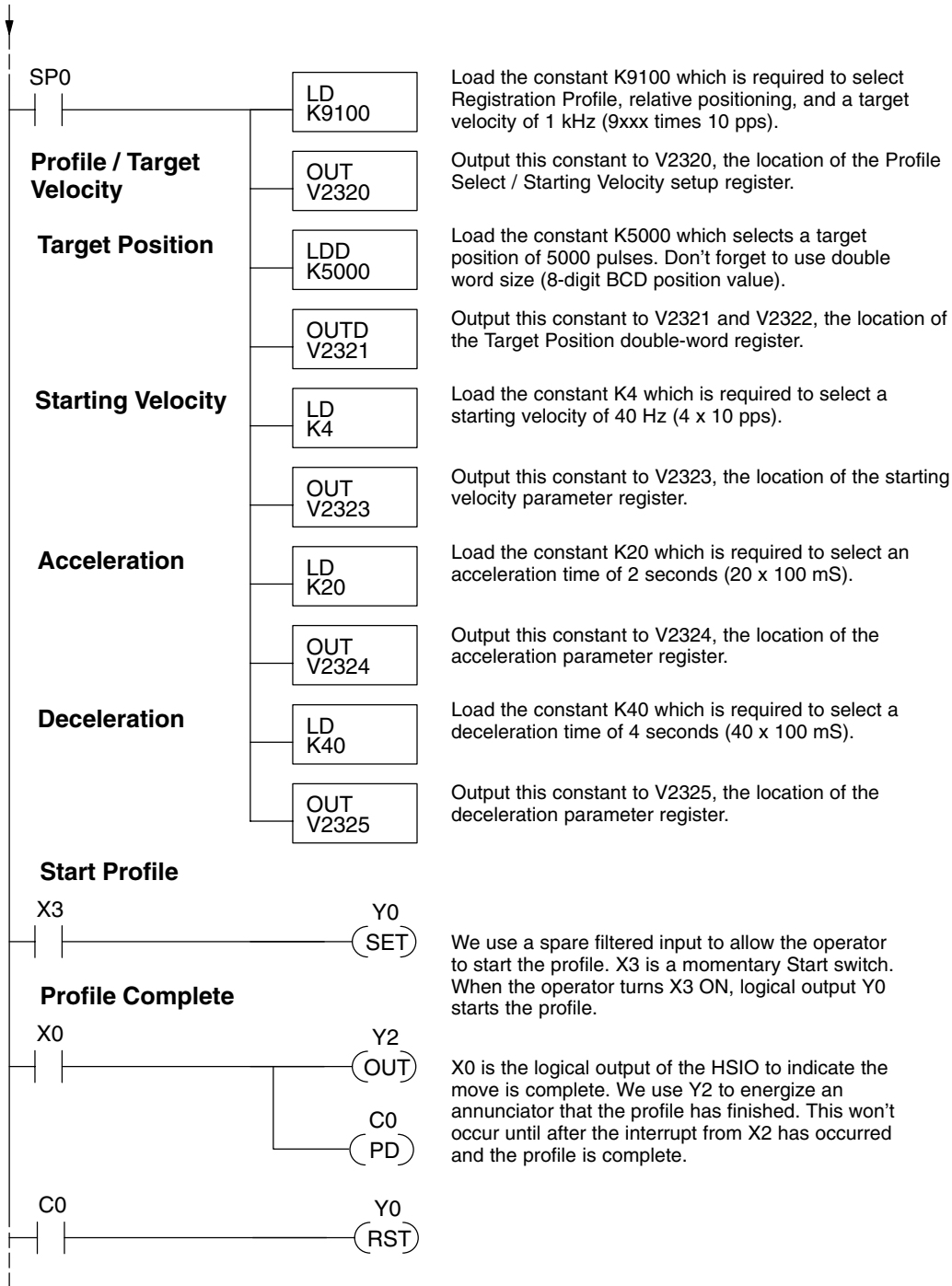

High-Speed Input and Pulse Output Features

The profile will begin when the start input (X3) is given. Then the motion begins an indefinite move, which lasts until an external interrupt on X2 occurs. Then the motion continues on for 5000 more pulses before stopping.

Home Search Program Example

One of the more challenging aspects of motion control is the establishment of actual position at powerup. This is especially true for open-loop systems which do not have a position feedback device. However, a simple limit switch located at an exact location on the positioning mechanism can provide “position feedback” at one point. For most stepper control systems, this method is a good and economical solution.

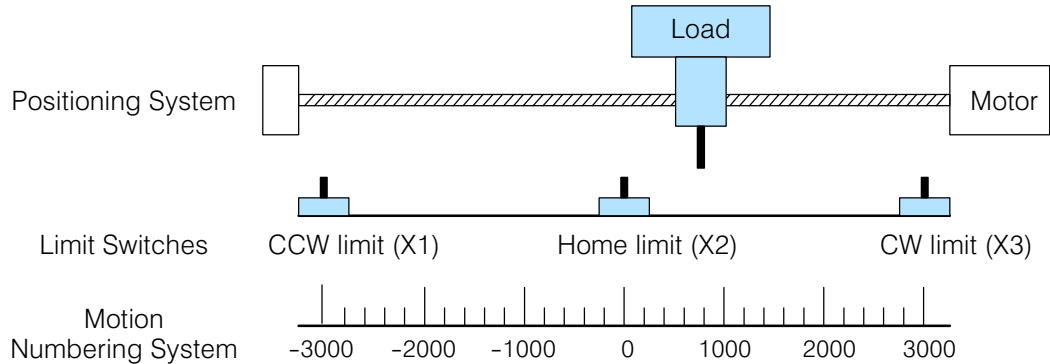

In the drawing above, the load moves left or right depending on the CCW/CW direction of motor rotation. The PLC ladder program senses the CCW and CW limit switches to stop the motor, before the load moves out-of-bounds and damages the machine. The home limit switch is used at powerup to establish the actual position. The numbering system is arbitrary, depending on a machine’s engineering units.

At powerup, we do not know whether the load is located to the left or to the right of the home limit switch. Therefore, we will initiate a *home search profile*, using the registration mode. The home limit switch is wired to X2, causing the interrupt. We choose an arbitrary initial search direction, moving in the CW (left-to-right) direction.

- If the home limit switch closes first, then we stop and initialize the position (this value is typically “0”, but it may be different if preferred).
- However, if the CW limit switch closes first, we must reverse the motor and move until the home limit switch closes, stopping just past it.

In the latter case, we repeat the first move, because we always need to make the final approach to the home limit switch *from the same direction*, so that the final *physical* position is the same in either case!

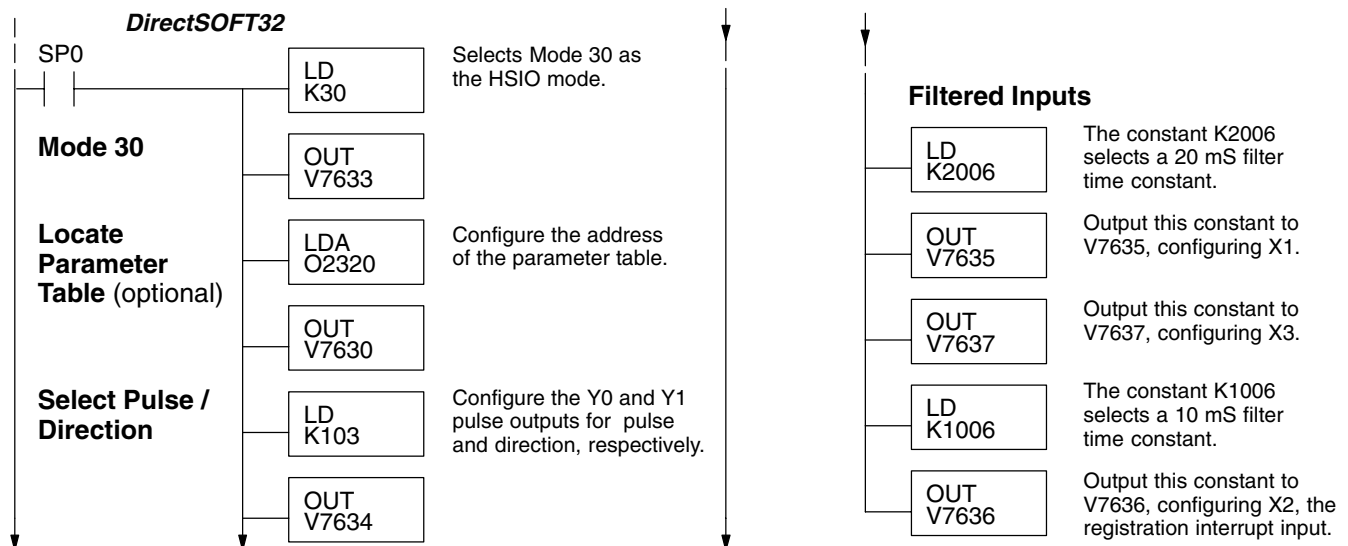

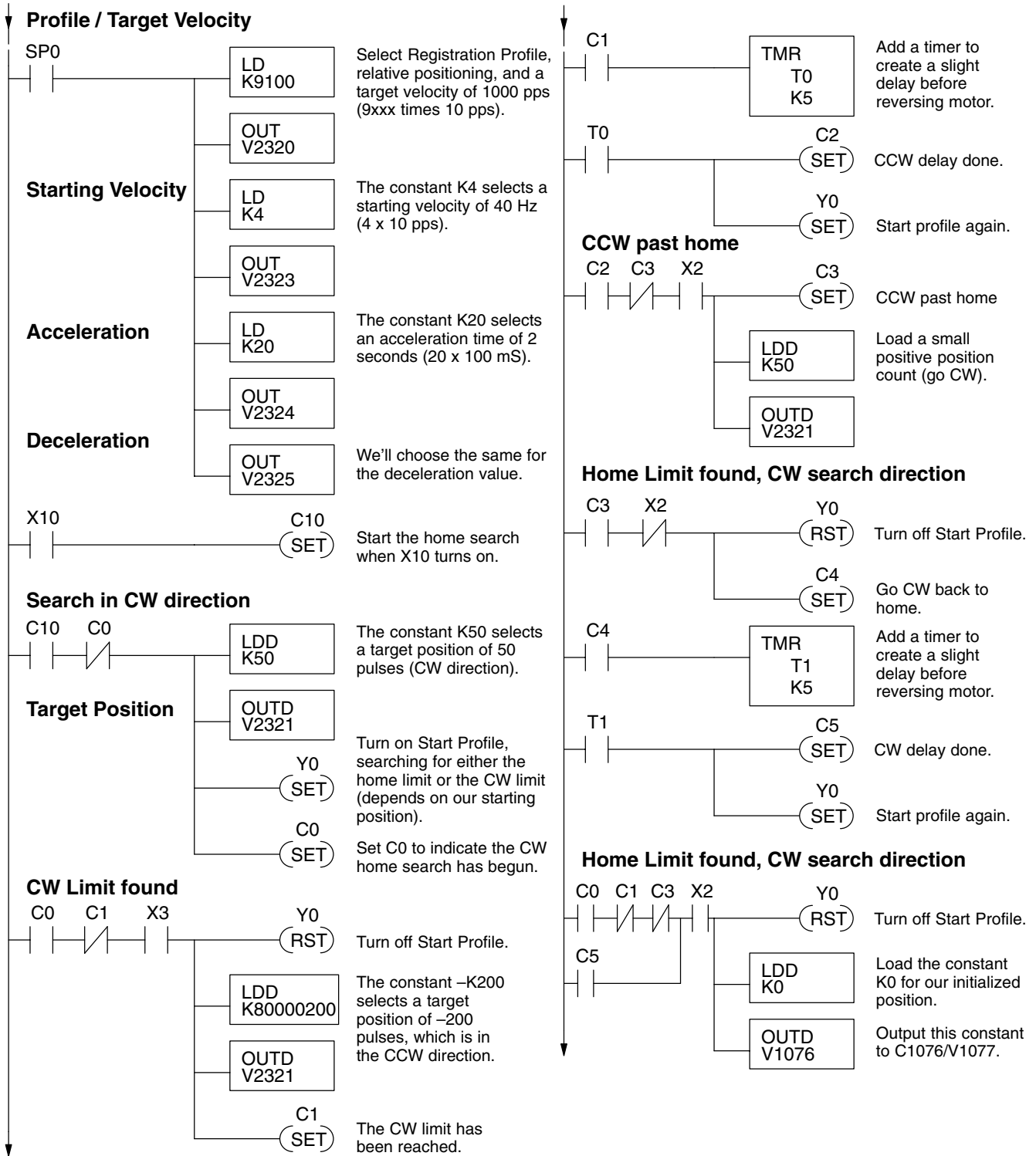

High-Speed Input and Pulse Output Features

The home search profile will execute specific parts of the program, based on the order of detection of the limit switches. Ladder logic sets C0 to initiate a home search in the CW direction. If the CW limit is encountered, the program searches for home in the CCW direction, passes it slightly, and does the final CW search for home. After reaching home, the last ladder rung preloads the current position to "0".

Velocity Profile Operation

Velocity Profile Applications

The velocity profile is best suited for applications which involve motion but do not require moves to specific points. Conveyor speed control is a typical example.

Velocity Profile

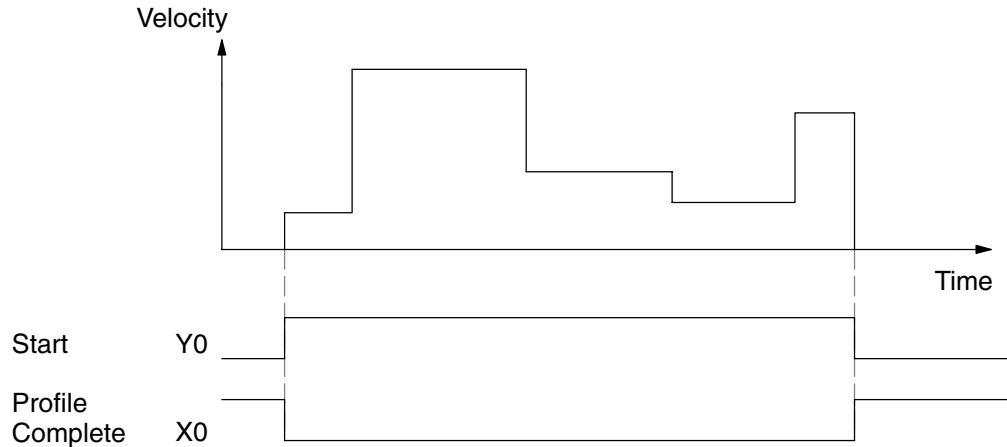

The time line of signal traces below the profile indicates the order of events. Assuming the velocity is set greater than zero, motion begins when the Start input (Y0) energizes. Since there is no end position target, the profile is considered in progress as long as the Start input remains active. The profile complete logical input to ladder logic (X0) correlates directly to the Start input status when velocity profiles are in use.

While the Start input is active, the ladder program can command a velocity change by writing a new value to the velocity register (V2323 by default). The full speed range of 40 Hz to 7 kHz is available. Notice from the drawing that there are no acceleration or deceleration ramps between velocity updates. This is how velocity profiling works with the HSIO. However, the ladder program can command more gradual velocity changes by incrementing or decrementing the velocity value more slowly. A counter or timer can be useful in creating your own acceleration/deceleration ramps. Unless the load must do a very complex move, it is easier to let the HSIO function generate the accel/decel ramps by selecting the trapezoidal or registration profiles instead.

Unlike the trapezoidal and registration profiles, you must specify the desired direction of travel with velocity profiles. Load the direction select register (V2321/V2322 by default) with 8000 0000 hex for CCW direction, or 0 for CW direction.

Velocity Profile Program Example

The velocity profile we want to perform is drawn and labeled in the following figure. Each velocity segment is of indefinite length. The velocity only changes when ladder logic (or other device writing to V-memory) updates the velocity parameter.

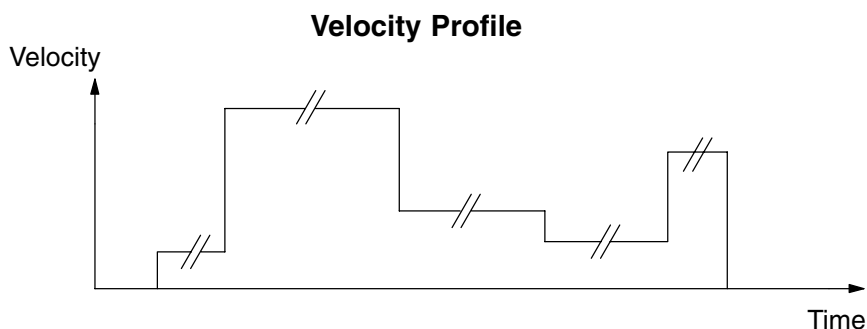

The following program uses dedicated discrete inputs to load in new velocity values. This is a fun program to try, because you can create an infinite variety of profiles with just two or three input switches. The intent is to turn on only one of X1, X2, or X3 at a time. The beginning of the program contains all the necessary setup parameters for Pulse Output Mode 30. We only have to do this once in the program, so we use first-scan contact SP0 to trigger the setup.

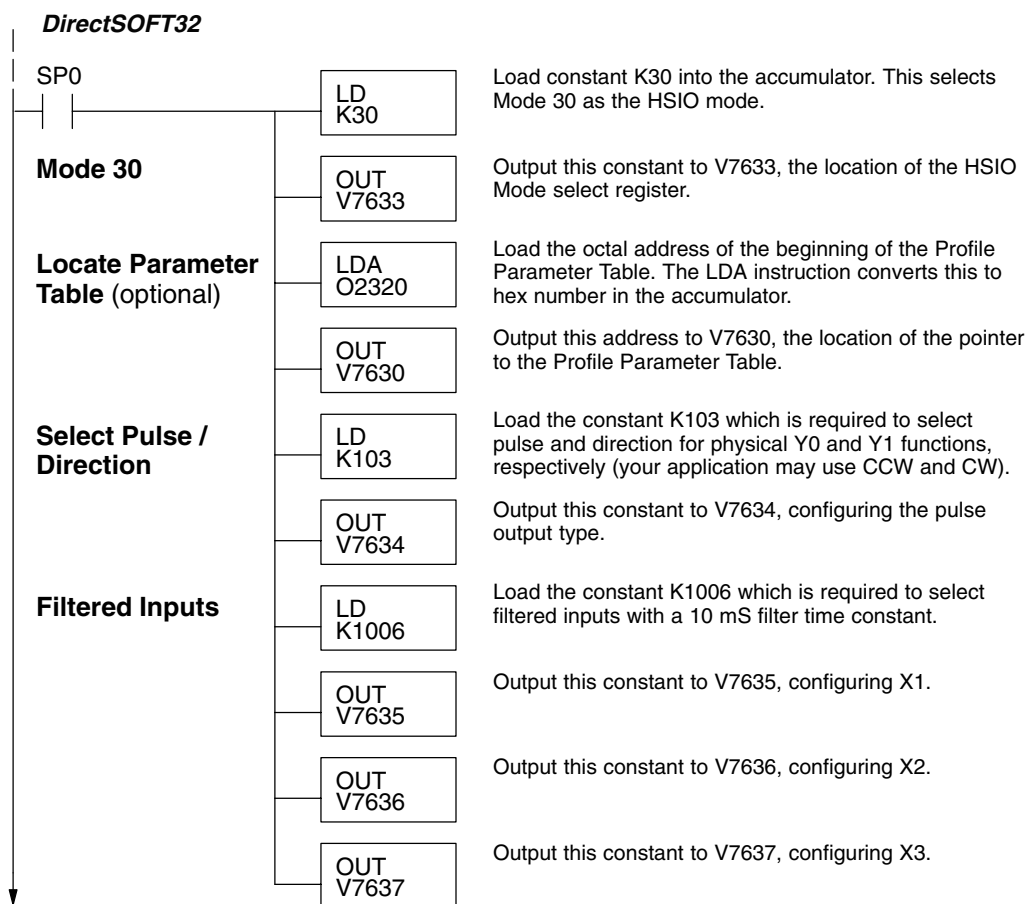

High-Speed Input and Pulse Output Features

Program Example Cont'd

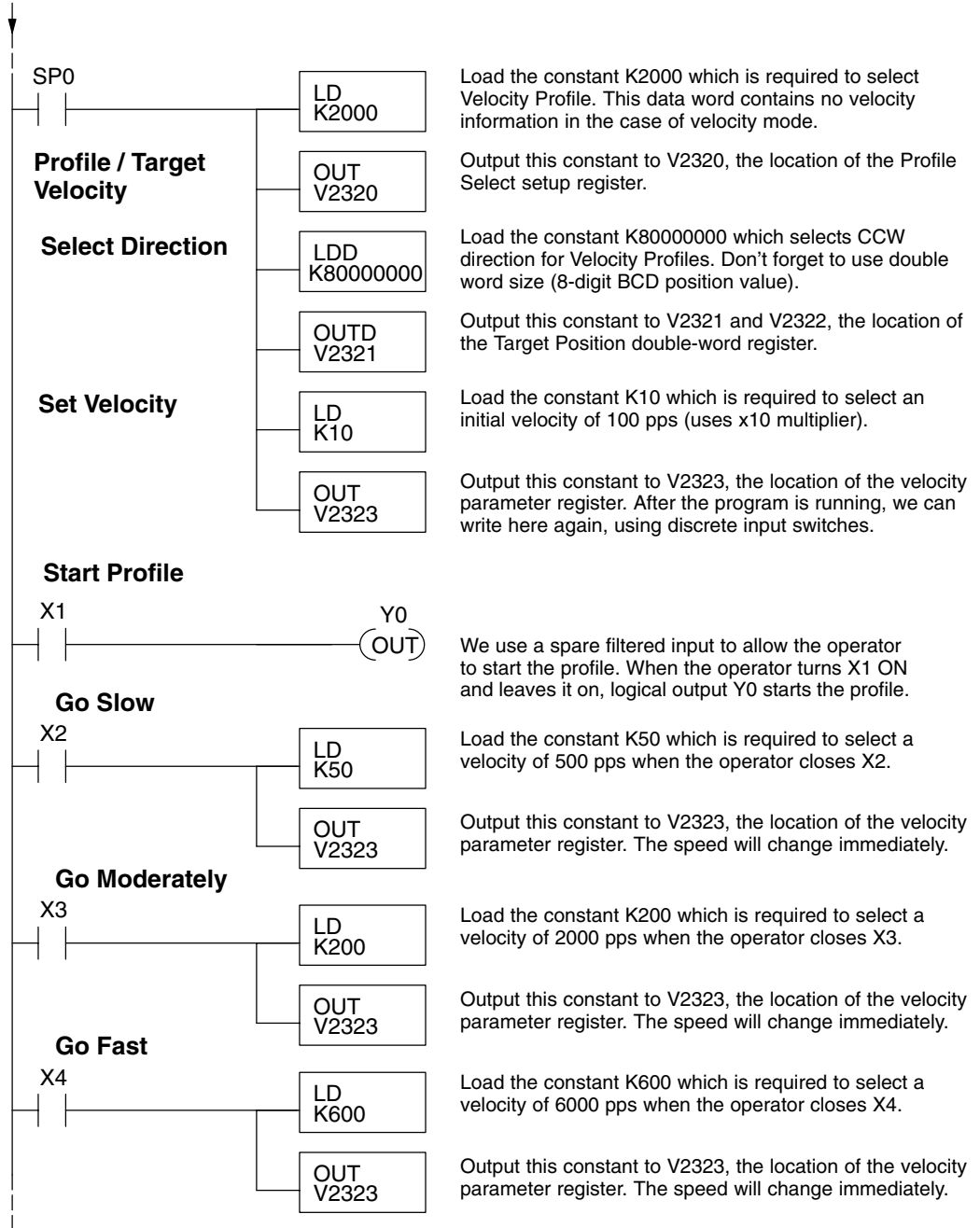

High-Speed Input and Pulse Output Features

Pulse Output Error Codes The Profile Parameter Table starting at V2320 (default location) defines the profile. Certain numbers will result in an error when the HSIO attempts to use the parameters to execute a move profile. When an error occurs, the HSIO writes an error code in V2326.

Error Code	Error Description
0000	No error
0010	Requested profile type code is invalid (must use 0, 1, 2, 8, or 9)
0020	Target Velocity is not in BCD
0021	Target Velocity is specified to be less than 40 pps
0022	Target Velocity is specified to be greater than 7,000 pps
0030	Target Position value is not in BCD
0040	Starting Velocity is not in BCD
0041	Starting Velocity is specified to be less than 40 pps
0042	Starting Velocity is specified to be greater than 1,000 pps
0050	Acceleration Time is not in BCD
0051	Acceleration Time is zero
0052	Acceleration Time is greater than 10 seconds
0010	Deceleration Time is not in BCD
0010	Deceleration Time is zero
0010	Deceleration Time is greater than 10 seconds

Most errors can be corrected by rechecking the Profile Parameter Table values. The error is automatically cleared at powerup and at Program-to-Run Mode transitions.

Troubleshooting Guide for Mode 30 If you're having trouble with Mode 30 operation, please study the following symptoms and possible causes. The most common problems are listed below:

Symptom: The stepper motor does not rotate.

Possible causes:

1. **Configuration** – Verify that the HSIO actually generates pulses on outputs Y0 and Y1. Watch the status LEDs for Y0 and Y1 when you start a motion profile. If the LEDs flicker on and off or are steadily on, the configuration is probably correct.
2. **Programming error** – If there are no pulses on Y0 or Y1 you may have a programming error. Check the contents of V2326 for an error code that may be generated when the PLC attempts to do the move profile. Error code descriptions are given above.

3. **Wiring** – Verify the wiring to the stepper motor is correct. Remember the signal ground connection from the PLC to the motion system is required.
4. **Motion system** – Verify that the drive is powered and enabled. To verify the motion system is working, you can use Mode 60 operation (normal PLC inputs/outputs) as shown in the test program below. With it, you can manually control Y0 and Y1 with X0 and X1, respectively. Using an input simulator is ideal for this type of manual debugging. With the switches you can single-step the motor in either direction. If the motor will not move with this simple control, Mode 30 operation will not be possible until the problem with the motor drive system or wiring is corrected.

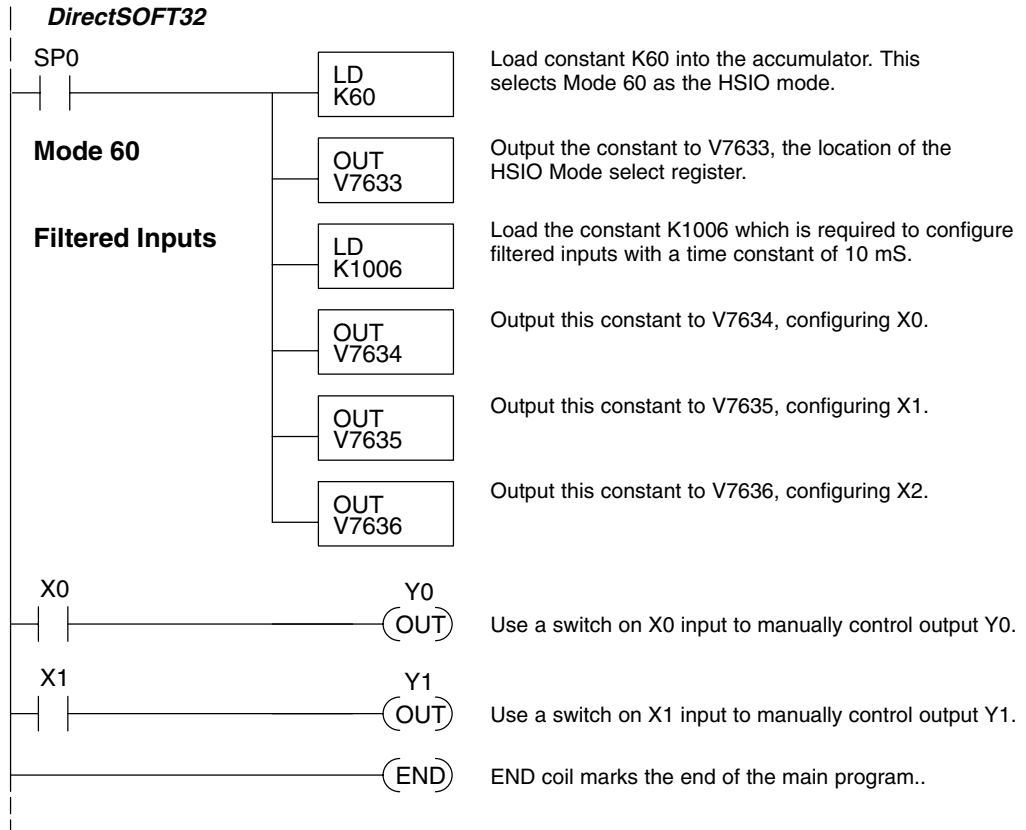

5. **Memory Error** – HSIO configuration parameters are stored in the CPU system memory. Corrupted data in this memory area can sometimes interfere with proper HSIO operation. If all other corrective actions fail, initializing the scratchpad memory may solve the problem. With *DirectSOFT32*, select the *PLC* menu, then *Setup*, then *Initialize Scratchpad*.

Symptom: The motor turns in the wrong direction.

Possible causes:

1. **Wiring** – If you have selected CW and CCW type operation, just swap the wires on Y0 and Y1 outputs.
2. **Direction control** – If you have selected Pulse and Direction type operation, just change the direction bit to the opposite state.

Mode 40: High-Speed Interrupts

Purpose

The HSIO Mode 40 provides a high-speed interrupt to the ladder program. This capability is provided for your choice of the following application scenarios:

- An external event needs to trigger an interrupt subroutine in the CPU. Using immediate I/O instructions in the subroutine is typical.
- An interrupt routine needs to occur on a timed basis which is different from the CPU scan time (either faster or slower). The timed interrupt is programmable, from 5 to 999 mS.

Functional Block Diagram

The HSIO circuit creates the high-speed interrupt to the CPU. The following diagram shows the external interrupt option, which uses X0. In this configuration, X1, X2, and X3 are all normal filtered inputs.

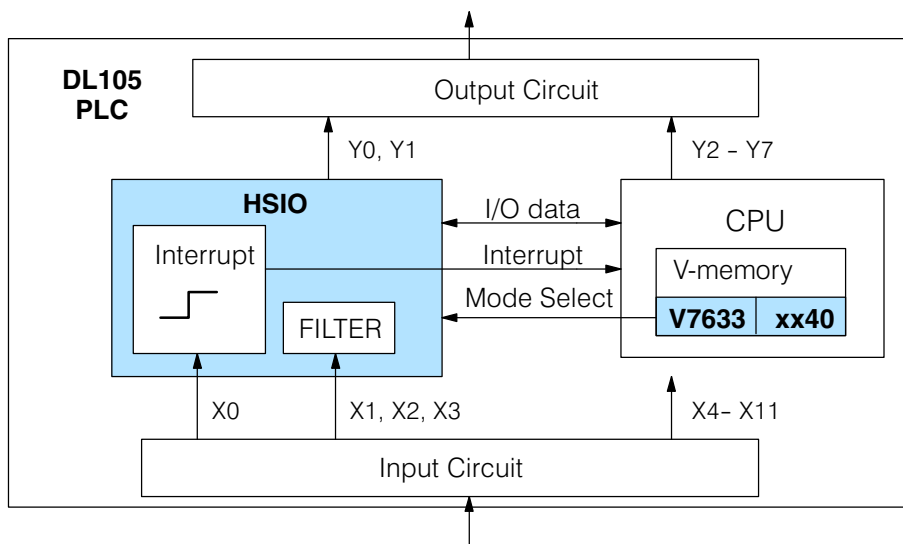

Alternately, you may configure the HSIO circuit to generate interrupts based on a timer, as shown below. In this configuration, inputs X0 through X3 are filtered inputs.

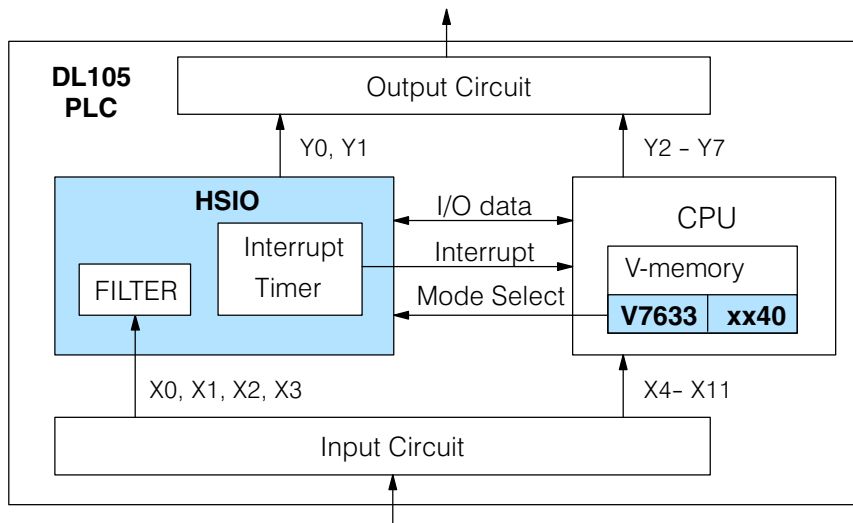

High-Speed Input and Pulse Output Features

Setup for Mode 40 Recall that V7633 is the HSIO Mode Select register. Refer to the diagram below. Use BCD 40 in the lower byte to select High-Speed Interrupt Mode. Use BCD 00 or 20 in the upper byte as required. Combine the two bytes into a data word “xx40”, for writing to V7633.

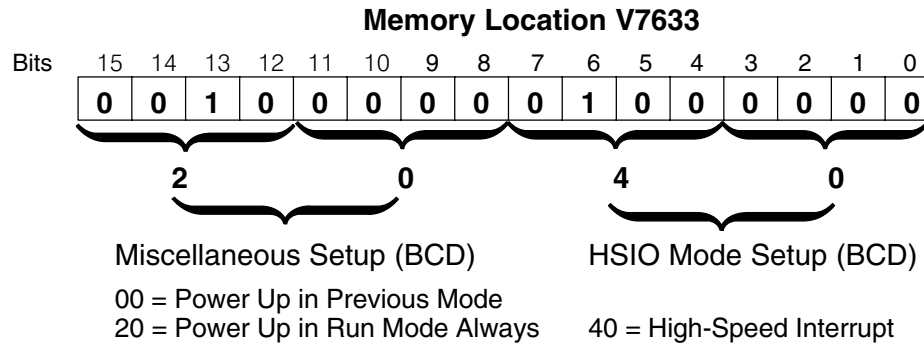

Choose the most convenient method of programming V7633 from the following:

- Include load and out instructions in your ladder program
- **DirectSOFT32's** memory editor
- Use the Handheld Programmer D2-HPP

We recommend using the first method above so that the HSIO setup becomes an integral part of your application program. An example program later in this section shows how to do this.

Interrupts and the Ladder Program

Refer to the drawing below. The source of the interrupt may be external (X0), or the HSIO timer function. The setup parameter in V7634 serves a dual purpose:

- It selects between the two interrupt sources, external (X0) or an internal timer.
- In the case of the timer interrupt, it programs the interrupt timebase between 5 and 999 mS.

The resulting interrupt uses label INT 0 in the ladder program. Be sure to include the Enable Interrupt (ENI) instruction at the beginning of your program. Otherwise, the interrupt routine will not be executed.

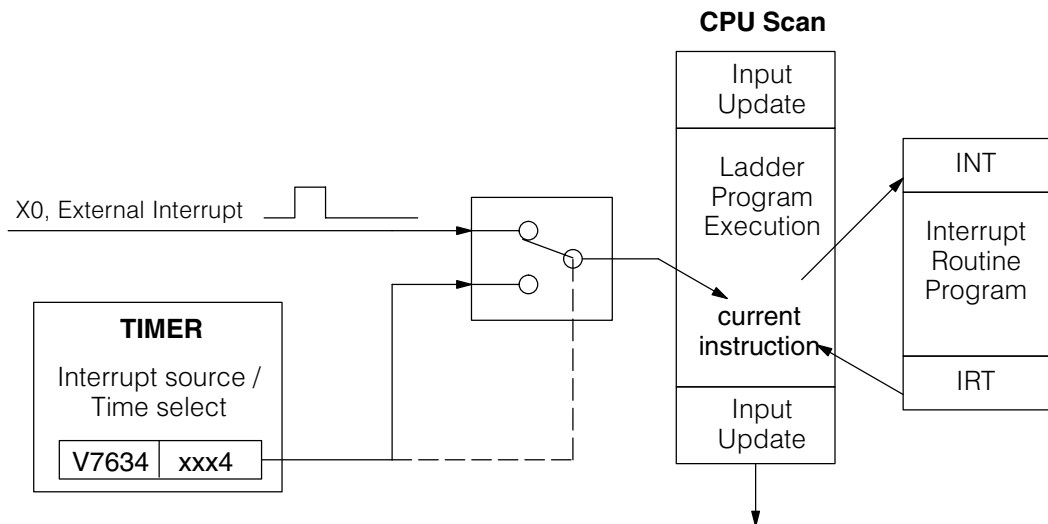

External Interrupt Timing Parameters

Signal pulses at X0 must meet certain timing criteria to guarantee an interrupt will result. Refer to the timing diagram below. The input characteristics of X0 are fixed (it is not a programmable filtered input). The minimum pulse width is 0.1 mS. There must be some delay before the next interrupt pulse arrives, such that the interrupt period cannot be smaller than 0.5 mS.

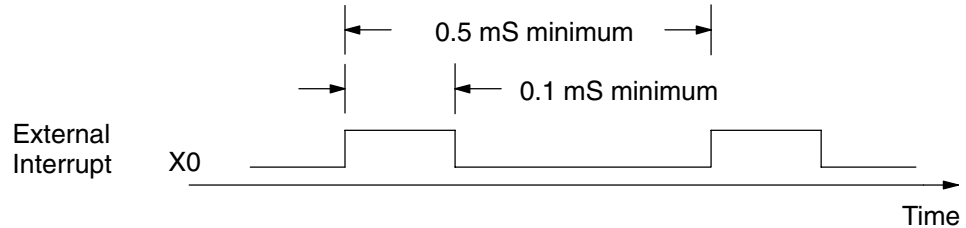

Timed Interrupt Parameters

When the timed interrupt is selected, the HSIO generates the interrupt to ladder logic. There is no interrupt “pulse width” in this case, but the interrupt period can be adjusted from 5 to 999 mS.

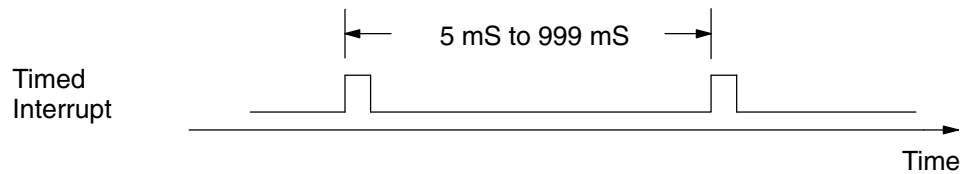

X Input / Timed INT Configuration

The configurable discrete input options for High-Speed Interrupt Mode are listed in the table below. Input X0 is the external interrupt when “0004” is in V7634. If you need a timed interrupt instead, then V7634 contains the interrupt time period, and input X0 becomes a filtered input (uses X1’s filter time constant by default). Inputs X1, X2, and X3 can only be filtered inputs, having individual configuration registers and filter time constants. However, X0 will have the same filter time constant as X1 when the timed interrupt is selected.

Input	Configuration Register	Function	Hex Code Required
X0	V7634	External Interrupt	0004
	Uses X1’s code in V7635	Filtered Input (when timed interrupt is in use)	0054 to 9994, which is the timed INT timebase
X1	V7635	Filtered Input	xx06 (xx = filter time)
X2	V7636	Filtered Input	xx06 (xx = filter time)
X3	V7637	Filtered Input	xx06 (xx = filter time)

External Interrupt Program Example

The following program selects Mode 40, then selects the external interrupt option. Inputs X1, X2, and X3 are all configured as filtered inputs with a 10 mS time constant. The program is otherwise generic, and may be adapted to your application.

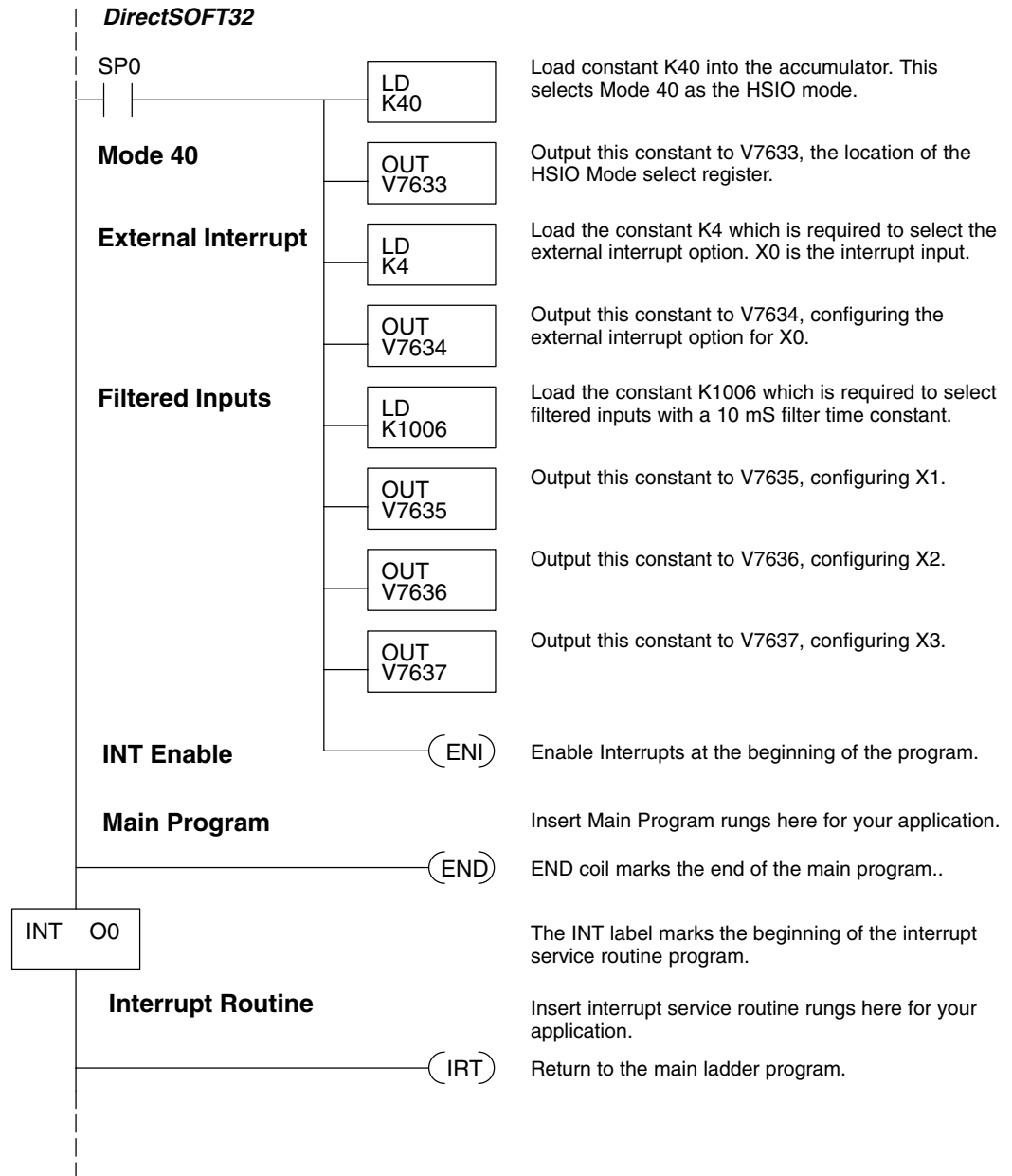

High-Speed Input and Pulse Output Features

Timed Interrupt Program Example

The following program selects Mode 40, then selects the timed interrupt option, with an interrupt period of 100 mS.

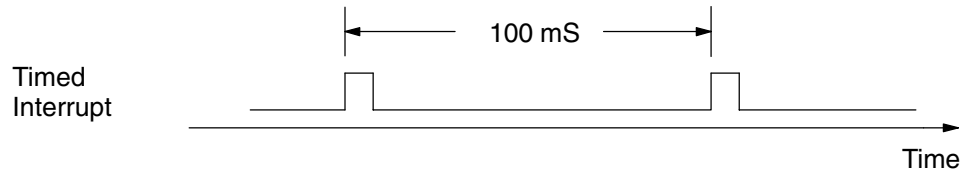

Inputs X0, X1, X2, and X3 are all configured as filtered inputs with a 10 mS time constant. Note that X0 uses the time constant from X1. The program is otherwise generic, and may be adapted to your application.

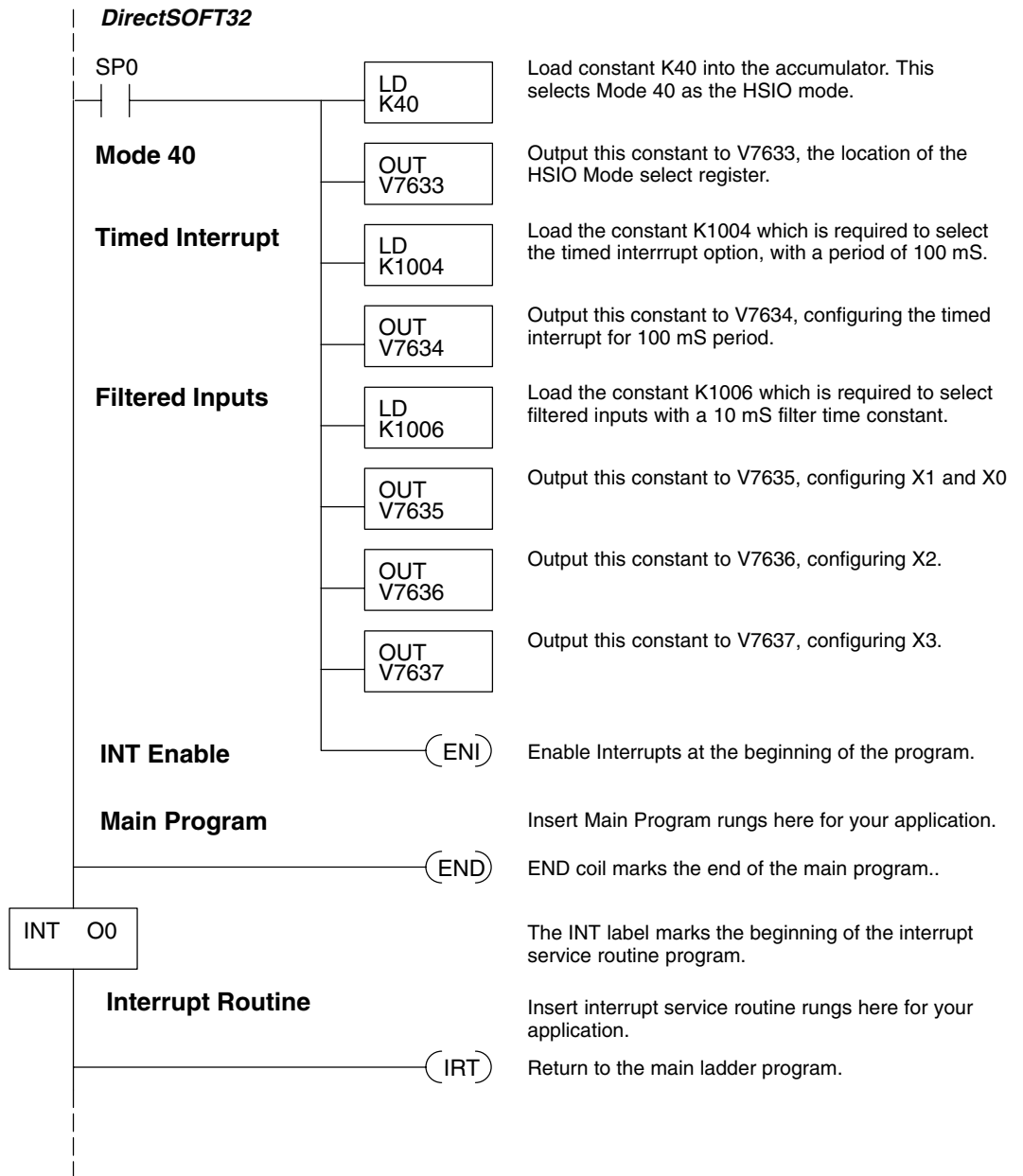

High-Speed Input and Pulse Output Features

Mode 50: Pulse Catch Input

Purpose

The HSIO circuit has a pulse-catch mode of operation. It monitors the signal on input X0, preserving the occurrence of a narrow pulse. The purpose of the pulse catch mode is to enable the ladder program to “see” an input pulse which is shorter in duration than the current scan time. The HSIO circuit latches the input event on input X0 for one scan, and presents it to ladder logic through special relay SP100 contact. This contact automatically goes off after one scan. *Note that the ladder program cannot read the status of X0 directly.*

Functional Block Diagram

Refer to the block diagram below. When the lower byte of HSIO Mode register V7633 contains a BCD “50”, the pulse catch mode in the HSIO circuit is enabled. X0 automatically becomes the pulse catch input, which sets the latch on each rising edge. The HSIO resets the latch at the end of the next CPU scan. The latch output is available to the ladder program through the special relay contact SP100. Inputs X1, X2, and X3 are available as filtered discrete inputs.

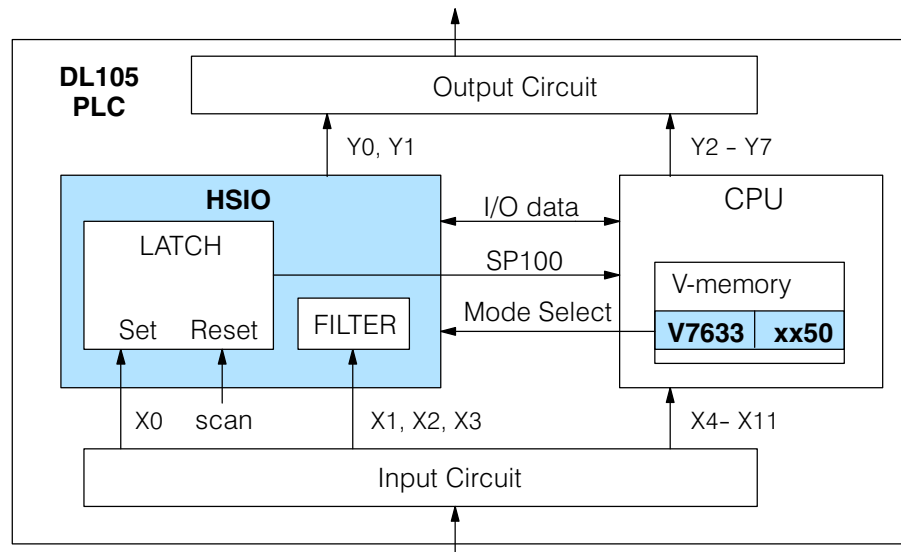

Pulse Catch Timing Parameters

Signal pulses at X0 must meet certain timing criteria to guarantee a pulse capture will result. Refer to the timing diagram below. The input characteristics of X0 are fixed (it is not a programmable filtered input). The minimum pulse width is 0.1 mS. There must be some delay before the next pulse arrives, such that the pulse period cannot be smaller than 0.5 mS. If the pulse period is smaller than 0.5 mS, the next pulse will be considered part of the current pulse.

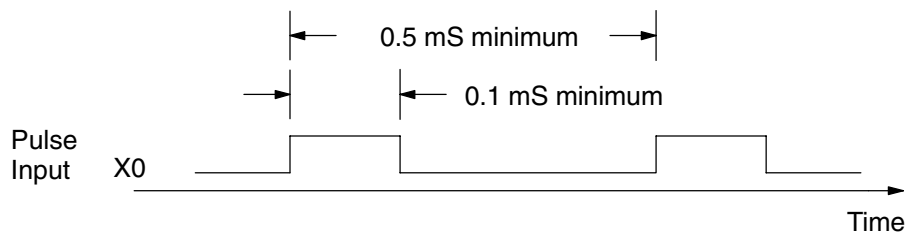

Note that the pulse catch and filtered input functions are opposite in nature. The pulse catch feature on X0 seeks to *capture* narrow pulses, while the filter input feature on X1, X2, and X3 seeks to *reject* narrow pulses.

Setup for Mode 50 Recall that V7633 is the HSIO Mode Select register. Refer to the diagram below. Use BCD 50 in the lower byte to select High-Speed Counter Mode. Use BCD 00 or 20 in the upper byte as required. Combine the two bytes into a data word “xx50”, for writing to V7633.

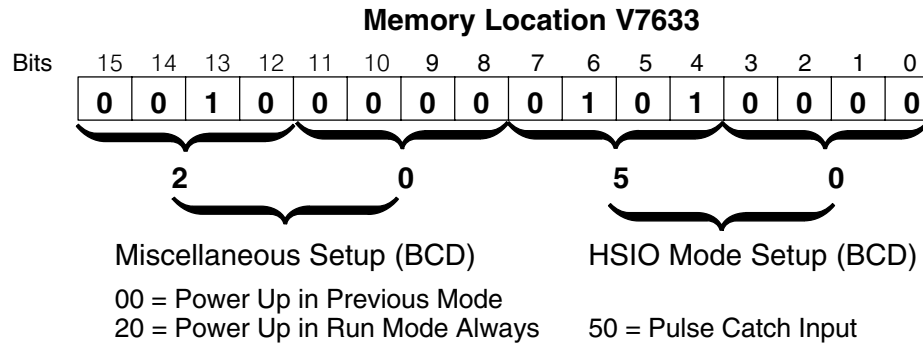

Choose the most convenient method of programming V7633 from the following:

- Include load and out instructions in your ladder program
- **DirectSOFT32's** memory editor
- Use the Handheld Programmer D2-HPP

We recommend using the first method above so that the HSIO setup becomes an integral part of your application program. An example program later in this section shows how to do this.

X Input Configuration

The configurable discrete input options for Pulse Catch Mode are listed in the table below. Input X0 is the pulse input, and must have “0005” loaded into its configuration register V7634. Inputs X1, X2, and X3 can only be filtered inputs. Each input has its own configuration register and filter time constant.

Input	Configuration Register	Function	Hex Code Required
X0	V7634	Pulse Catch Input	0005
X1	V7635	Filtered Input	xx06 (xx = filter time)
X2	V7636	Filtered Input	xx06 (xx = filter time)
X3	V7637	Filtered Input	xx06 (xx = filter time)

Pulse Catch Program Example

The following program selects Mode 50, then programs the pulse catch code for X0. Inputs X1, X2, and X3 are all configured as filtered inputs with 10, 30, and 50 mS time constants respectively. The program is otherwise generic, and may be adapted to your application.

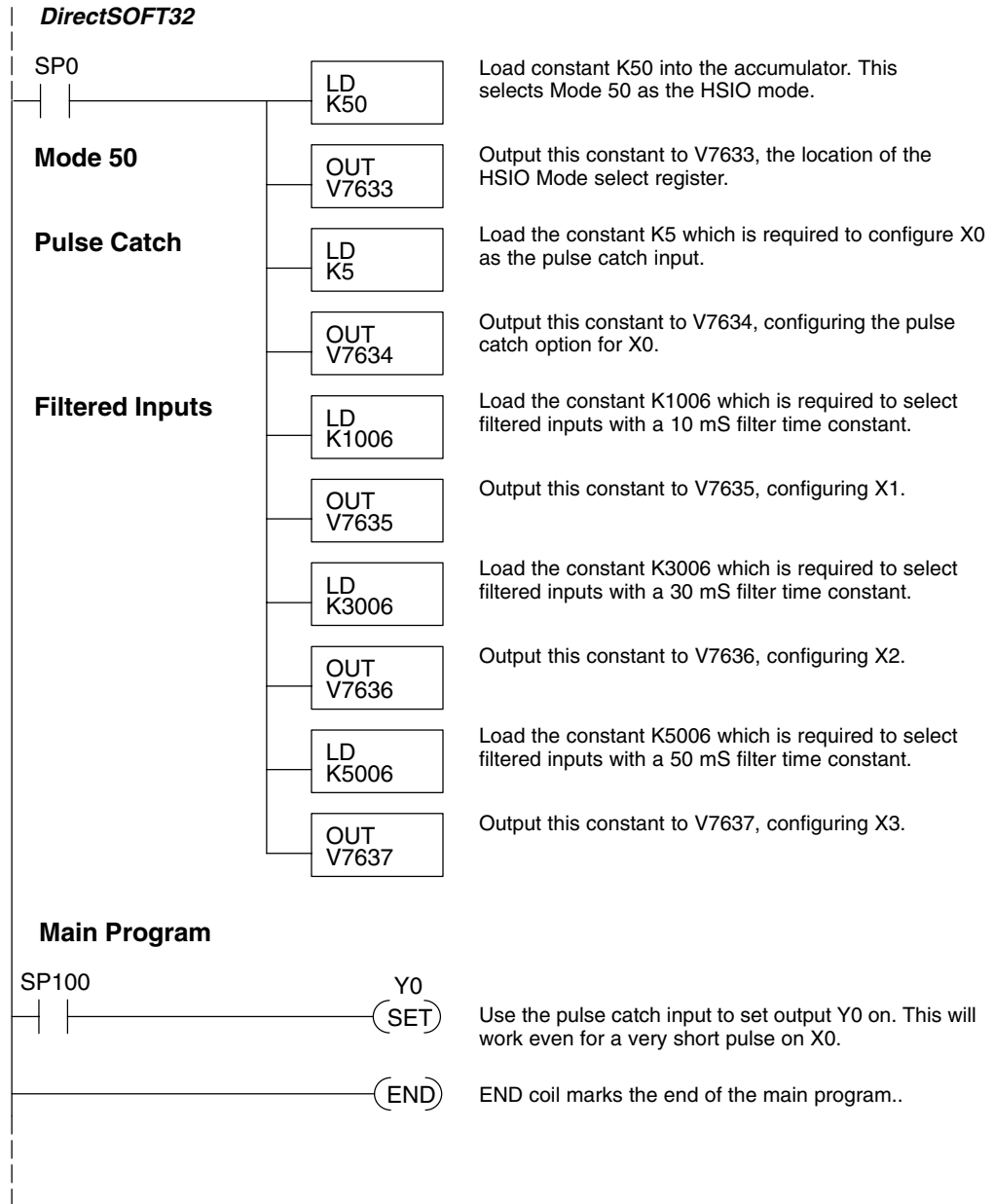

High-Speed Input and Pulse Output Features

Mode 60: Discrete Inputs with Filter

Purpose

The last mode we will discuss for the HSIO circuit is Mode 60, Discrete Inputs with Filter. The purpose of this mode is to allow the input circuit to reject narrow pulses and accept wide ones, as viewed from the ladder program. This is useful in especially noisy environments or other applications where pulse width is important. In all other modes in this chapter, X0 to X3 usually support the mode functions as special inputs. Only spare inputs operate as filtered inputs by default. Now in Mode 60, all four inputs X0 through X3 function only as discrete filtered inputs.

Functional Block Diagram

Refer to the block diagram below. When the lower byte of HSIO Mode register V7633 contains a BCD "60", the input filter in the HSIO circuit is enabled. Each input X0 through X3 has its own filter time constant. The filter circuit assigns the outputs of the filters as logical references X0 through X3.

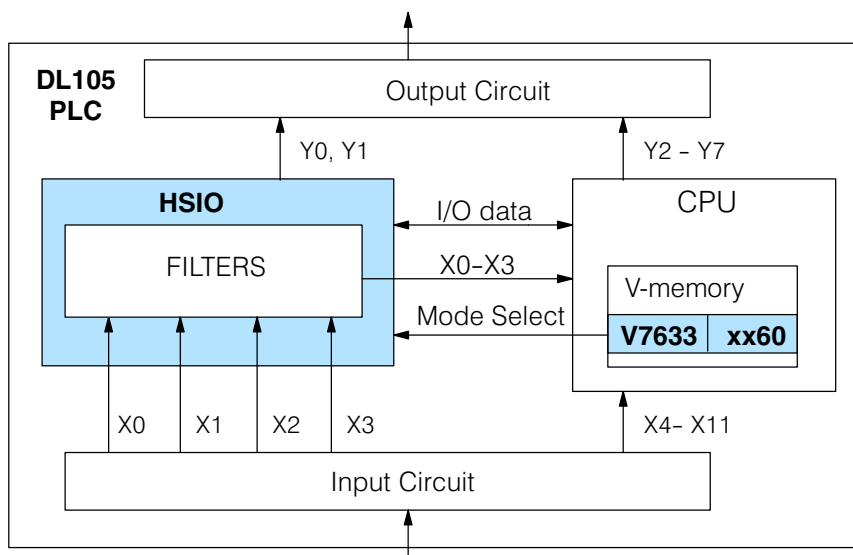

Input Filter Timing Parameters

Signal pulses at inputs X0 – X3 are filtered by using a delay time. In the figure below, the input pulse on the top line is longer than the filter time. The resultant logical input to ladder is phase-shifted (delayed) by the filter time on both rising and falling edges. In the bottom waveforms, the physical input pulse width is smaller than the filter time. In this case, the logical input to the ladder program remains in the OFF state (input pulse was filtered out).

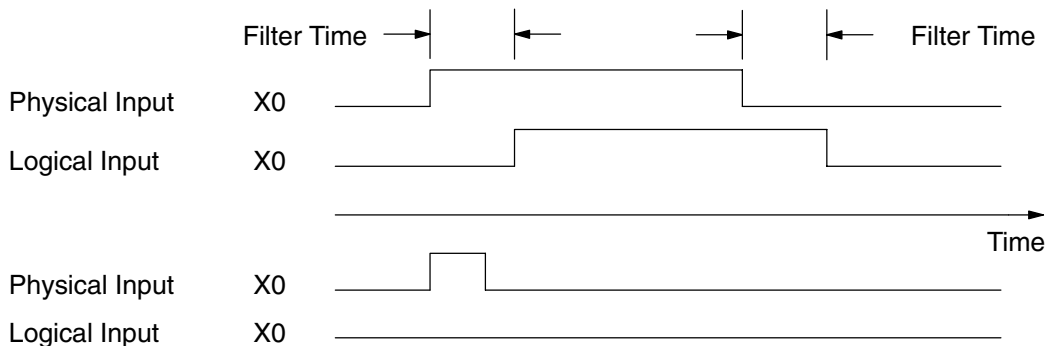

High-Speed Input and Pulse Output Features

Setup for Mode 60 Recall that V7633 is the HSIO Mode Select register. Refer to the diagram below. Use BCD 60 in the lower byte to select High-Speed Counter Mode. Use BCD 00 or 20 in the upper byte as required. Combine the two bytes into a data word “xx60”, for writing to V7633.

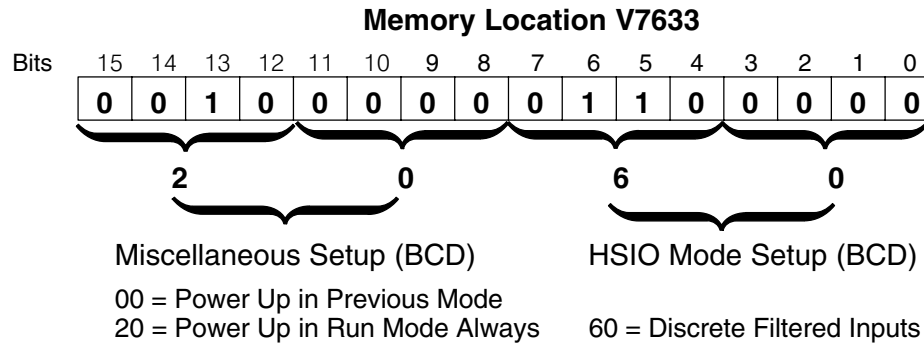

Choose the most convenient method of programming V7633 from the following:

- Include load and out instructions in your ladder program
- **DirectSOFT32's** memory editor
- Use the Handheld Programmer D2-HPP

We recommend using the first method above so that the HSIO setup becomes an integral part of your application program. An example program later in this section shows how to do this.

X Input Configuration

The configurable discrete input options for Discrete Filtered Inputs Mode are listed in the table below. The filter time constant (delay) is programmable from 10 to 99 mS. The code for this selection occupies the upper byte of the configuration register in BCD. We combine this number with the required “06” in the lower byte to get “xx06”, where xx = 10 to 99. Input X0, X1, X2, and X3 can only be filtered inputs. Each input has its own configuration register and filter time constant.

Input	Configuration Register	Function	Hex Code Required
X0	V7634	Filtered Input	xx06 (xx = filter delay time)
X1	V7635	Filtered Input	xx06 (xx = filter delay time)
X2	V7636	Filtered Input	xx06 (xx = filter delay time)
X3	V7637	Filtered Input	xx06 (xx = filter delay time)

Filtered Inputs Program Example

The following program selects Mode 60, then programs the filter delay time constants for inputs X0, X1, X2, and X3. Each filter time constant is different, for illustration purposes. The program is otherwise generic, and may be adapted to your application.

