

F2-04AD-1, F2-04AD-1L, 4-CHANNEL ANALOG CURRENT INPUT



In This Chapter...

Module Specifications	2-2
Setting the Module Jumpers	2-6
Connecting the Field Wiring	2-7
Module Operation	2-10
Writing the Control Program.....	2-14

Module Specifications

F2-04AD-1

The F2-04AD-1 analog Input module provides several hardware features.

- On-board 250 ohm, 1/2 Watt precision resistors provide substantial over-current-protection for 4–20mA current loops.
- Analog inputs are optically isolated from the PLC logic.
- The module has a removable terminal block so the module can be easily removed or changed without disconnecting the wiring.
- With a D2-240, D2-250-1, D2-260 or D2-262 CPU, all four channels can be read in one scan.
- On-board active analog filtering and RISC-like microcontroller provide digital signal processing to maintain precision analog measurements in noisy environments.

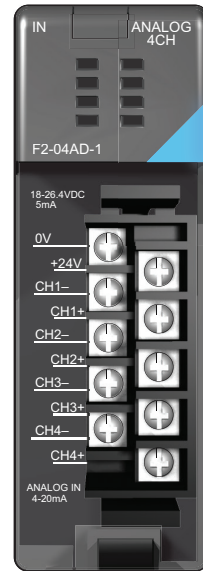

F2-04AD-1L is Obsolete



NOTE: In 2009 the F2-04AD-1L was discontinued. A re-designed F2-04AD-1 was released at the same time which can be powered by either 12VDC or 24VDC input power supplies. This new module is a direct replacement for legacy F2-04AD-1 and all F2-04AD-1L modules. The new module is a single circuit board design so the jumper link locations are different. See “Setting the Module Jumpers” on page 2-6. Also, some specifications were changed on page 2-3. Otherwise, the re-designed module functions the same as the prior designs.

All specifications are the same for both modules except for the input voltage requirements. Review these specifications to make sure the module meets your application requirements.

Input Specifications	
Number of Channels	4, single ended (one common)
Input Range	4–20 mA current
Resolution	12 bit (1 in 4096)
Step Response	4.9 ms (*4.0 ms) to 95% of full step change
Crosstalk	-80 dB, 1/2 count maximum
Active Low-pass Filtering	-3 dB at 120Hz (*80Hz), 2 poles (-12dB per octave)
Input Impedance	250Ω ±0.1% 1/2 W current input
Absolute Maximum Ratings	±40mA, current input
Converter type	Successive approximation
Linearity Error (End to End)	±1 count (0.025% of full scale) maximum
Input Stability	±1 count
Full Scale Calibration Error (Offset error not included)	±12 counts maximum @ 20mA current input
Offset Calibration Error	±7 counts maximum @ 4mA current input
Maximum Inaccuracy	± 0.5% @ 25°C (77°F) ±0.65% 0–60°C (32–140°F)
Accuracy vs. Temperature	±50ppm/°C maximum full scale calibration (including maximum offset change)
Recommended Fuse (external)	0.032 A, Series 217 fast-acting, current inputs

General Specifications	
PLC Update Rate	1 channel per scan maximum (D2-230 CPU) 4 channels per scan maximum (D2-240, D2-250-1, D2-260 or D2-262 CPU)
Digital Inputs	12 binary data bits, 2 channel ID bits, 2 diagnostic bits
Input points required	16 point (X) input module
Power Budget Requirement	100mA (*50mA maximum, 5VDC (supplied by base)
External Power Supply	F2-04AD-1: 5mA, 10–30 VDC (*80mA max, 18–30 VDC), F2-04AD-1L: *90mA max, 10–15 VDC
Operating Temperature	0°C to 60°C (32°F to 140°F)
Storage Temperature	-20°C to 70°C (-4°F to 158°F)
Relative Humidity	5–95% (non-condensing)
Environmental Air	No corrosive gases permitted
Vibration	MIL STD 810C 514.2
Shock	MIL STD 810C 516.2
Noise Immunity	NEMA ICS3-304



NOTE: Values in parenthesis with an **asterisk** are for older modules with two circuit board design and date codes 0609F3 or previous. Values not in parenthesis are for single circuit board models with date code 0709G or above.

Analog Input Configuration Requirements

The analog input module will appear as a 16-point discrete input module and can be installed in any slot of a DL205 system. The available power budget and discrete I/O points are the limiting factors. For more information check the user manual for the CPU model and I/O base being used regarding power budget and number of local, local expansion or remote I/O points.

Special Placement Requirements (D2-230 and Remote I/O Bases)

Even though the module can be placed in any slot, it is important to examine the configuration if a D2-230 CPU is used, as can be seen in the section about **Writing the Program** located in this chapter. V-memory locations are used to extract the analog data. If the module is placed so the input points do not start on a V-memory boundary, the instructions cannot access the data. This also applies when placing this module in a remote base using a D2-RSSS in the CPU slot.

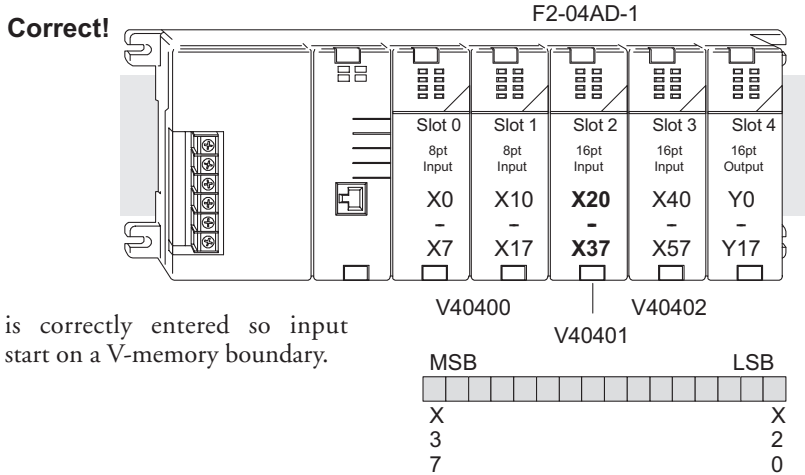

Data is correctly entered so input points start on a V-memory boundary.

Incorrect

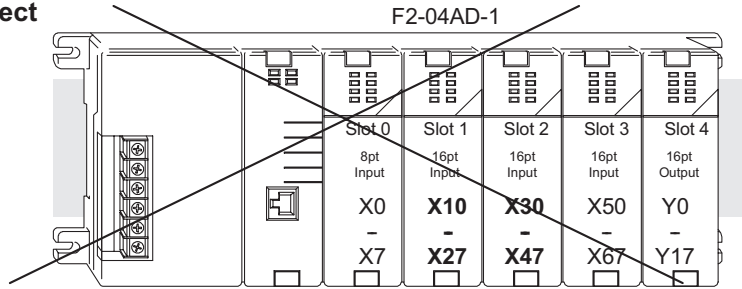

Data is split over two locations, so instructions cannot access data from a D2-230.

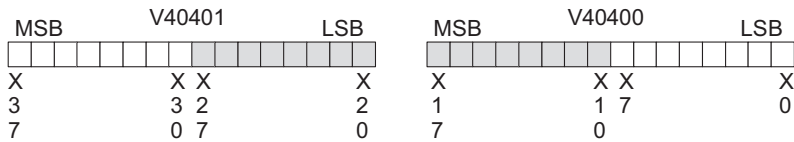

To use the V-memory references required for a D2-230 CPU, the *first* input address assigned to the module must be one of the following X locations. The table also shows the V-memory addresses that correspond to these X locations.

X	X0	X20	X40	X60	X100	X120	X140	X160
V	V40400	V40401	V40402	V40403	V40404	V40405	V40406	V40407

Setting the Module Jumpers

Selecting the Number of Channels

There are two jumpers, labeled +1 and +2, that are used to select the number of channels that will be used. Use the figures below to locate the jumpers on the module. The module is set from the factory for four channel operation.

The unused channels are not processed, so if only channels 1 thru 3 are selected, then channel 4 will not be active. The following table shows how to use the jumpers to select the number of channels.

No. of Channels	+1	+2
1	No	No
1, 2	Yes	No
1, 2, 3	No	Yes
1, 2, 3, 4	Yes	Yes

For example, to select all 4 channels (1–4), leave both jumpers installed.
To select channel 1, remove both jumpers

Jumper location on modules having date code 0609F3 and previous (two circuit board design)

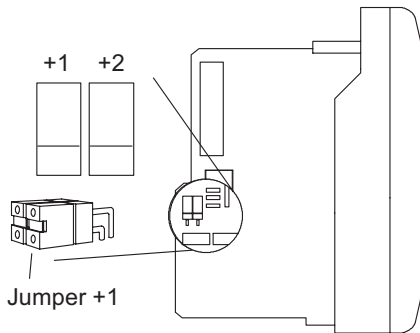

These jumpers are located on the motherboard, the one with the black D-shell style backplane connector.

Jumper location on modules having date code 0709G and above (single circuit board design)

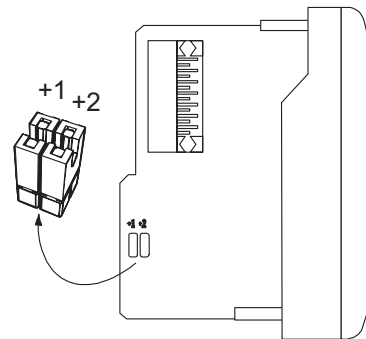

Connecting the Field Wiring

Wiring Guidelines

Your company may have guidelines for wiring and cable installation. If so, check them before starting the installation. Here are some general things to consider:

- Use the shortest wiring route whenever possible.
- Use shielded wiring and ground the shield at the transmitter source. *Do not* ground the shield at both the module and the source.
- Do not run the signal wiring next to large motors, high current switches, or transformers. This may cause noise problems.
- Route the wiring through an approved cable housing to minimize the risk of accidental damage. Check local and national codes to choose the correct method for your application.

User Power Supply Requirements

The F2-04AD-1 module requires at least one field-side power supply. The same or separate power sources can be used for the module supply and the current transmitter supply. The module requires 10–30 VDC, at 5mA, from the external power supply. The DL205 AC bases have a built-in 24VDC power supply that provide up to 300mA of current. This can be used instead of a separate supply. Check the power budget to be safe.

It is desirable in some situations to power the transmitters separately in a location remote from the PLC. This will work as long as the transmitter supply meets the voltage and current requirements, and the transmitter's minus (-) side and the module supply's minus (-) side are connected together.



WARNING: If using the 24VDC base power supply, make sure to calculate the power budget. Exceeding the power budget can cause unpredictable system operation that can lead to a risk of personal injury or damage to equipment.

The DL205 base has a switching type power supply. As a result of switching noise, ± 3 –5 counts of instability may be noticed in the analog input data if the base power supply is used. If this is unacceptable, try one of the following:

1. Use a separate linear power supply.
2. Connect the 24VDC common to the frame ground, which is the screw terminal marked on the screw terminal marked “G” on the base.

By using these methods, the input stability is rated at ± 1 count.

Current Loop Transmitter Impedance

Standard 4–20 mA transmitters and transducers can operate from a wide variety of power supplies. Not all transmitters are alike and the manufacturers often specify a minimum loop or load resistance that must be used with the transmitter.

The F2-04AD-1, provides 250Ω resistance for each channel. If the transmitter being used requires a load resistance below 250Ω, it is not necessary to make any adjustments. However, if the transmitter requires a load resistance higher than 250Ω, a resistor will need to be added in series with the input.

Consider the following example for a transmitter being operated from a 30VDC supply with a recommended load resistance of 750Ω. Since the module has a 250Ω resistor, an additional resistor needs to be added.

$$R = Tr - Mr$$

$$R = 750 - 250$$

$$R \geq 500$$

R - Resistor to add
Tr - Transmitter Requirement
Mr - Module resistance (internal 250Ω)

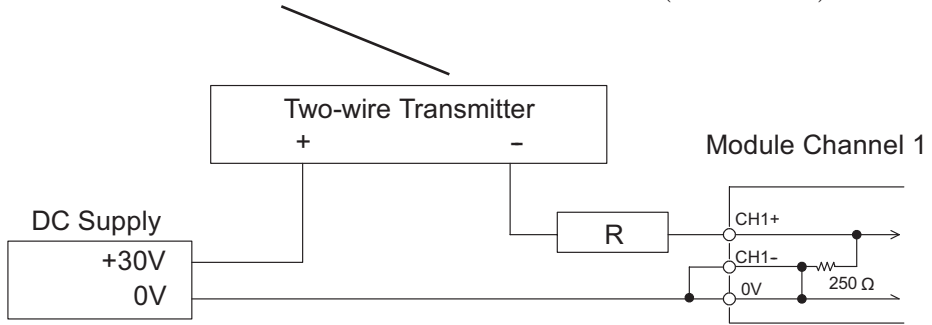

Wiring Diagram

The F2-04AD-1, module has a removable connector to simplify wiring the module. Just squeeze the top and bottom retaining clips and gently pull the connector from the module. Use the following diagram to connect the field wiring.

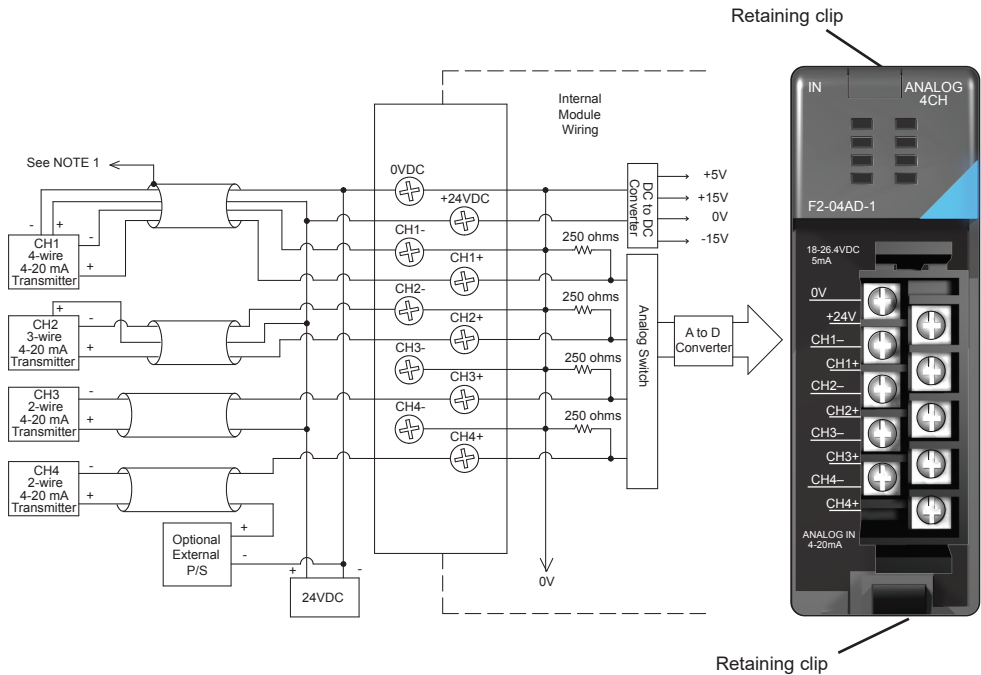

NOTE 1: Shields should be grounded at the signal source.

NOTE 2: More than one external power supply can be used, provided all the power supply commons are connected.

NOTE 3: A Series 217, 0.032 A fast-acting fuse is recommended for 4–20 mA current loops.

NOTE 4: If the power supply common of an external power supply is not connected to 0 VDC on the module, then the output of the external transmitter must be isolated. To avoid "ground loop" errors, recommended 4–20 mA transmitter types are:

2 or 3 wire: Isolation between input signal and power supply.

4 wire: Isolation between input signal, power supply, and 4–20 mA output.

Module Operation

Channel Scanning Sequence (Multiplexing) for a D2-230 CPU

Before beginning to write the control program, it is important to take a few minutes to understand how the module processes and represents the analog signals.

The module can supply different amounts of data per scan, depending on the type of CPU being used. The D2-230 can obtain one channel of data per CPU scan. Since there are four channels, it can take up to four scans to get data for all channels. Once all channels have been scanned the process starts over with channel 1. Unused channels are not processed, so if only two channels are selected, then each channel will be updated every other scan. The multiplexing method can also be used for the D2-240, D2-250-1, D2-260 and D2-262 CPUs.

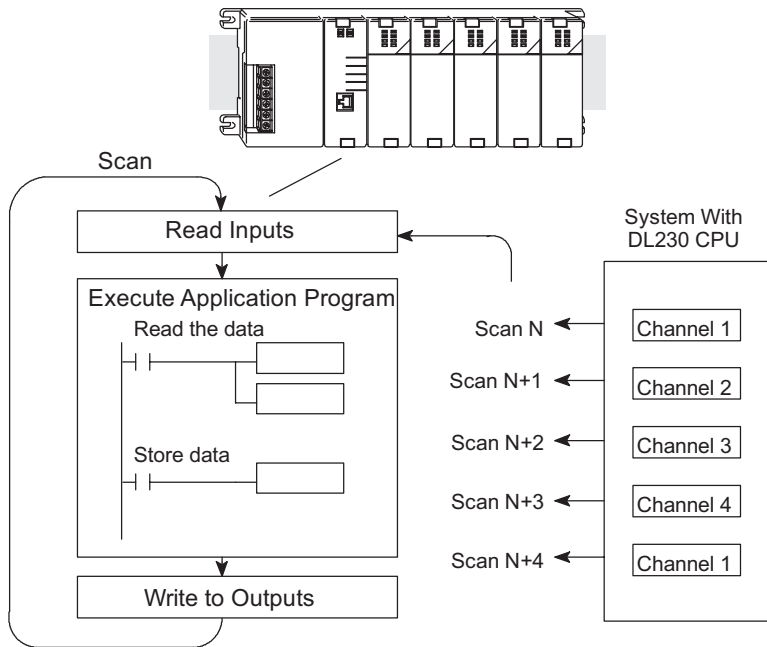

Channel Scanning Sequence (Pointer method) for D2-240, D2-250-1, D2-260 or D2-262 CPU

If a D2-240, a D2-250-1, a D2-260 or a D2-262 CPU is used, all four channels of input data can be collected in one scan. This is because the D2-240, D2-250-1, D2-260 and D2-262 CPU supports special V-memory locations that are used to manage the data transfer. This is discussed in more detail in the section on **Writing the Control Program** later in this chapter.

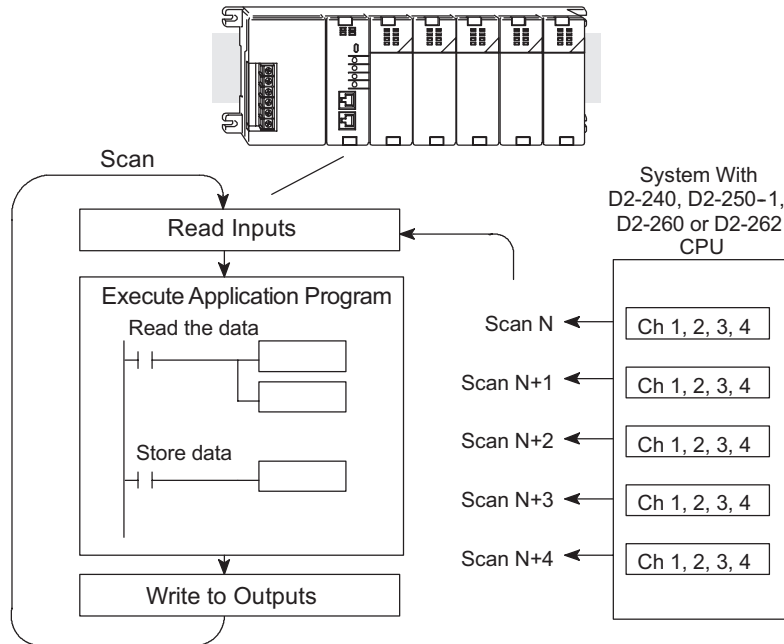

Analog Module Updates

Even though the channel updates to the CPU are synchronous with the CPU scan, the module asynchronously monitors the analog transmitter signal and converts the signal to a 12-bit binary representation. This enables the module to continuously provide accurate measurements without slowing down the discrete control logic in the RLL program.

For the vast majority of applications, the values are updated much faster than the signal changes. However, in some applications, the update time can be important. The module takes approximately 4.9 milliseconds to sense 95% of the change in the analog signal.



NOTE: This is not the amount of time required to convert the signal to a digital representation. The conversion to the digital representation takes only a few microseconds. Many manufacturers list the conversion time, but it is the settling time of the filter that really determines the update time.

Understanding the Input Assignments

It was mentioned earlier in this chapter that the F2-04AD-1 module appears as a 16-point discrete input module to the CPU. These points can be used to obtain:

- An indication of which channel is active
- The digital representation of the analog signal
- Module diagnostic information

Since all input points are automatically mapped into V-memory, it is very easy to determine the location of the data word that will be assigned to the module.

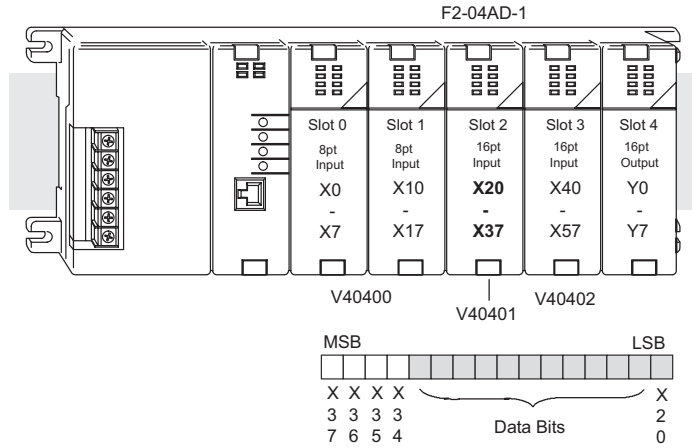

Within these word locations, the individual bits represent specific information about the analog signal.

Analog Data Bits

The first twelve bits represent the analog format.

Bit	Value	Bit	Value
0	1	6	
1	2	7	
2	4	8	
3	8	9	512
4	16	10	1024
5	32	11	2048

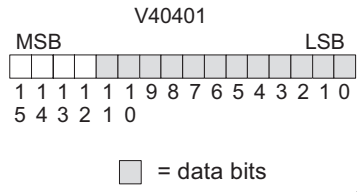

Active Channel Indicator Inputs

Two of the inputs are binary-encoded to indicate the active channel (remember, the V-memory bits are mapped directly to discrete inputs). The inputs are automatically turned on and off to indicate the active channel for each scan.

Scan	X35	X34	Channel
N	Off	Off	1
N+1	Off	On	2
N+2	On	Off	3
N+3	On	Off	4
N+4	Off	Off	1

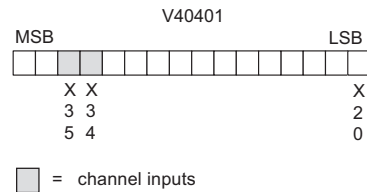

Module Diagnostic Inputs

The last two inputs are used for module diagnostics.

Module Busy - The first diagnostic input (X36 in this example) indicates a "busy" condition. This input will always be active on the first PLC scan, to tell the CPU the analog data is not valid. After the first scan, the input usually only comes on when extreme environmental (electrical) noise problems are present.

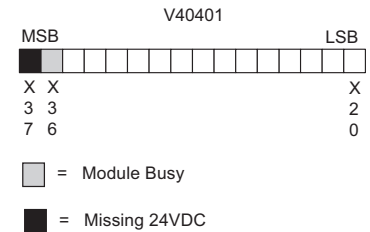

The programming examples in the next section shows how this input can be used. The wiring guidelines shown earlier in this chapter provide steps that can help reduce noise problems.

Missing 24VDC - The last diagnostic input (X37 in this example) indicates that 24VDC has not been applied to the card. For example, when using the multiplexing method, if the 24VDC input power is missing or if the terminal block is loose, the module will turn on this input point and it also returns a data value of zero to further indicate there is a problem. If using the pointer method, the value placed into the V-memory location will be 8000 instead of bit 15 (i.e. X37 in this example) being set.

The next section, **Writing the Control Program**, explains how these inputs can be used in a program.

Module Resolution

Since the module has 12-bit resolution, the analog signal converted into 4096 counts ranging from 0 - 4095 (2¹²). For example, a 4mA signal would be 0 and a 20mA signal would be 4095. This is equivalent to a binary value of 0000 0000 0000 to 1111 1111 1111, or 000 to F hexadecimal. The diagram shows how this relates to the signal range.

Each count can also be expressed in terms of the signal level by using the equation shown.

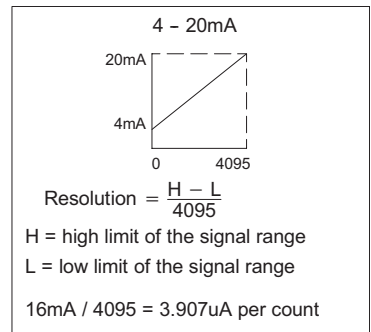

Writing the Control Program

Reading Values: Pointer Method and Multiplexing

There are two methods which can be used to read values:

- The pointer method
- Multiplexing

The multiplexing method must be used when using a D2-230 CPU. The multiplexing method must also be used with remote I/O modules (the pointer method will not work). Either method can be used with the D2-240, D2-250-1, D2-260 and D2-262 CPUs, but for ease of programming it is strongly recommended to use the pointer method.

Pointer Method for D2-240, D2-250-1, D2-260 and D2-262

The DL205 series has special V-memory locations assigned to each base slot that will greatly simplify the programming requirements. These V-memory locations allow you to:

- Specify the data format
- Specify the number of channels to scan
- Specify the storage locations.



NOTE: D2-250 CPUs with firmware release version 1.06 or later support this method. If the D2-230 example needs to be used, module placement in the base is very important. Review the section earlier in this chapter for guidelines.

The example program shows how to setup these locations. Place this rung anywhere in the ladder program, or in the initial stage if stage programming instructions are being used. This is all that is required to read the data into V-memory locations. Once the data is in V-memory, math can be used on the data to compare the data against preset values, and so forth. V2000 is used in the example but you can use any user V-memory location. In this example the module is installed in slot 2. Be sure to use the V-memory locations for the module placement. The pointer method automatically converts values to BCD (depending on the LD statement in the ladder logic).

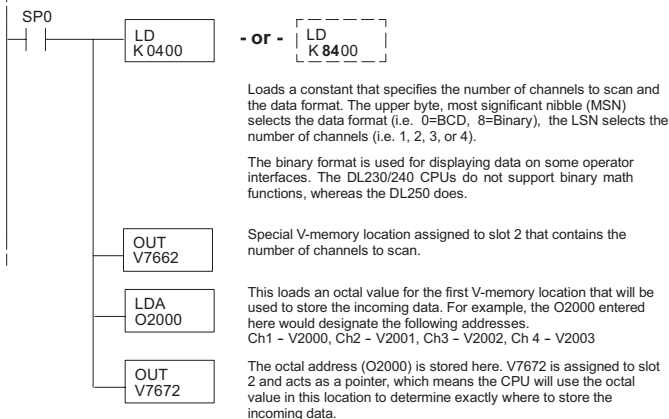

The tables below show the special V-memory locations used by the D2-240, D2-250-1, D2-260 and D2-262 for the CPU base and local expansion base I/O slots. Slot 0 (zero) is the module next to the CPU or the D2-CM module. Slot 1 is the module two places from the CPU or the D2-CM, and so on. Remember, the CPU only examines the pointer values at these locations after a mode transition. Also, if the D2-230 (multiplexing) method is used, verify that these addresses in the CPU are zero.

The table below applies to the D2-240, D2-250-1, D2-260 and D2-262 CPU base.

CPU Base: Analog Input Module Slot-Dependent V-memory Locations								
Slot	0	1	2	3	4	5	6	7
No. of Channels	V7660	V7661	V7662	V7663	V7664	V7665	V7666	V7667
Storage Pointer	V7670	V7671	V7672	V7673	V7674	V7675	V7676	V7677

The table below applies to the D2-250-1, D2-260 or D2-262 expansion base 1.

Expansion Base D2-CM #1: Analog Input Module Slot-Dependent V-memory Locations								
Slot	0	1	2	3	4	5	6	7
No. of Channels	V36000	V36001	V36002	V36003	V36004	V36005	V36006	V36007
Storage Pointer	V36010	V36011	V36012	V36013	V36014	V36015	V36016	V36017

The table below applies to the D2-250-1, D2-260 or D2-262 expansion base 2.

Expansion Base D2-CM #2: Analog Input Module Slot-Dependent V-memory Locations								
Slot	0	1	2	3	4	5	6	7
No. of Channels	V36100	V36101	V36102	V36103	V36104	V36105	V36106	V36107
Storage Pointer	V36110	V36111	V36112	V36113	V36114	V36115	V36116	V36117

The table below applies to the D2-260 and D2-262 CPU expansion base 3.

Expansion Base D2-CM #3: Analog Input Module Slot-Dependent V-memory Locations								
Slot	0	1	2	3	4	5	6	7
No. of Channels	V36200	V36201	V36202	V36203	V36204	V36205	V36206	V36207
Storage Pointer	V36210	V36211	V36212	V36213	V36214	V36215	V36216	V36217

The table below applies to the D2-260 and D2-262 CPU expansion base 4.

Expansion Base D2-CM #4: Analog Input Module Slot-Dependent V-memory Locations								
Slot	0	1	2	3	4	5	6	7
No. of Channels	V36300	V36301	V36302	V36303	V36304	V36305	V36306	V36307
Storage Pointer	V36310	V36311	V36312	V36313	V36314	V36315	V36316	V36317

Reading Values (Multiplexing) for D2-230, D2-240, D2-250-1, D2-260 and D2-262 CPUs

The D2-230 CPU *does not* have the special V-memory locations which will allow data transfer to be automatically enabled. Since all channels are multiplexed into a single data word, the control program must be setup to determine which channel is being read. Since the module appears as X input points to the CPU, it is very easy to use the active channel status bits to determine which channel is being monitored.



NOTE: This example is for a module installed as shown in the previous examples. The addresses used would be different if the module was installed in a different I/O arrangement. The rungs can be placed anywhere in the program, or if stage programming is being used, place them in a stage that is always active.

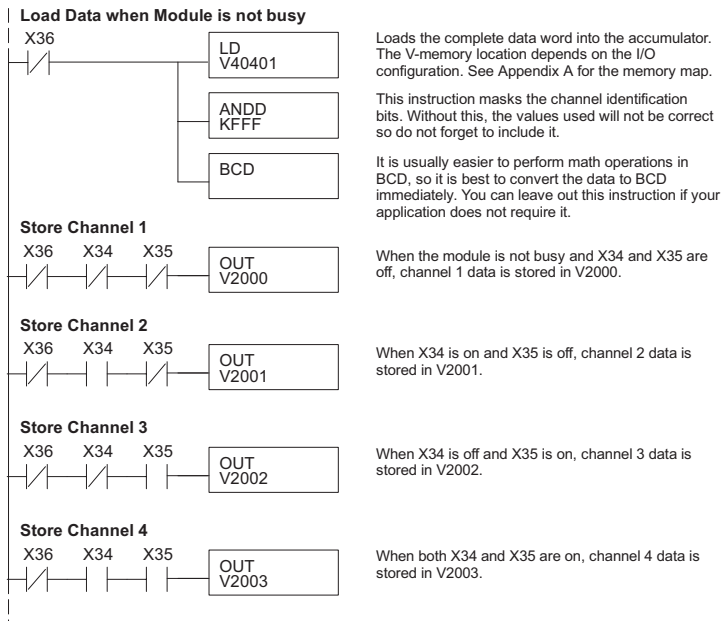

Single Channel Selected

Since it isn't necessary to know which channel is selected, the single channel program is even more simple as shown in the example below.

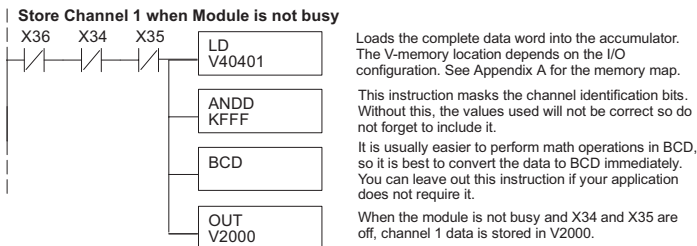

Analog Power Failure Detection

The Analog module has an on-board processor that can diagnose analog input circuit problems. A ladder rung can be edited to detect these problems. This rung shows an input point that would be assigned if the module was installed as shown in the previous examples. A different point would be used if the module was installed in a different I/O arrangement.

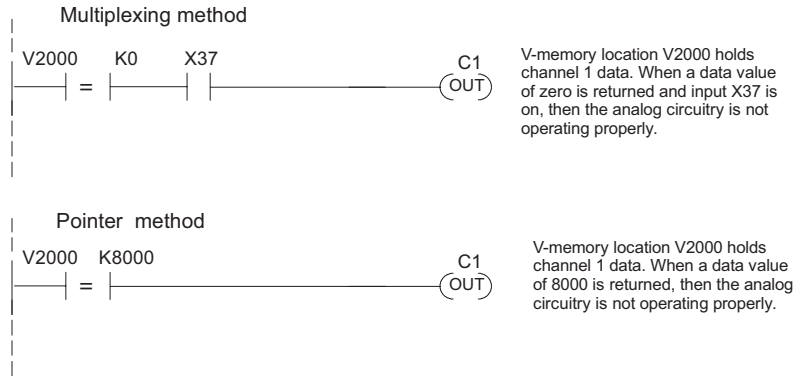

Scaling the Input Data

Most applications require measurements in engineering units which provides more meaningful data. This is accomplished by using the conversion formula shown.

Adjustments may be needed to the formula depending on the scale being used for the engineering units.

For example, if pressure (psi) is to be measured from 0.0 – 99.9 then multiply the value by 10 in order to imply a decimal place when viewing the value with the programming software or with a handheld programmer. Notice how the calculations differ when the multiplier is used.

Units = A $\frac{H-L}{4095}$

U = Engineering Units

A = Analog Value (0 – 4095)

H = High limit of the engineering unit range

L = Low limit of the engineering unit range

An analog value of 2024, slightly less than half scale, should yield 49.4 psi.

Example without multiplier

$$\text{Units} = A \frac{H-L}{4095}$$

$$\text{Units} = 2024 \frac{100-0}{4095}$$

$$\text{Units} = 49$$

Example with multiplier

$$\text{Units} = 10A \frac{H-L}{4095}$$

$$\text{Units} = 20240 \frac{100-0}{4095}$$

$$\text{Units} = 494$$

The Conversion Program

The following example shows how to write the program to perform the engineering unit conversion. This example assumes that the data is in BCD and loaded into the appropriate V-memory locations using instructions that apply the CPU being used in the PLC.



NOTE: This example uses SP1, which is always on, but any permissive contact such as X, C, etc., can be used.

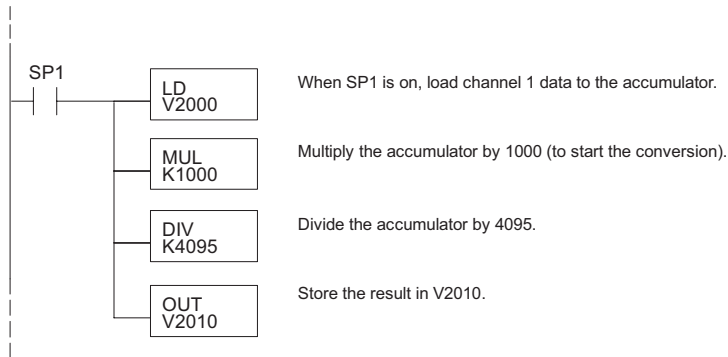

Analog and Digital Value Conversions

Sometimes it is useful to be able to quickly convert between the signal levels and the digital values. This is especially helpful during machine startup or troubleshooting. The following table provides formulas to make this conversion more simple.

Range	If the digital value is known	If the analog signal level is known.
4–20 mA	$A = \frac{16D}{4095} + 4$	$D = \frac{4095}{16} (A - 4)$

As an example, if the measured signal is 10mA, the formula can be used to easily determine the digital value that will be stored in the V-memory location that contains the data.

$$D = \frac{4095}{16} (A - 4)$$

$$D = \frac{4095}{16} (10\text{mA} - 4)$$

$$D = (255.93) (6) \quad D = 1536$$

Filtering Input Noise for D2-250-1, D2-260 and D2-262 CPUs Only

Add the following logic to filter and smooth analog input noise in D2-250-1, D2-260 and D2-262 CPUs. This is especially useful when using PID loops. Noise can be generated by the field device and/or induced by field wiring.

In the following example, the analog value in BCD is first converted to a binary number. Memory location V1400 is the designated work space in this example. The MULR instruction is the filter factor, which can be from 0.1 to 0.9. The example uses 0.2. A smaller filter factor increases filtering. A higher precision value can be used, but it is not generally needed. The filtered value is then converted back to binary and then to BCD. The filtered value is stored in location V1402 for use in your application or PID loop.

NOTE: Please review intelligent instructions (IBox) in Chapter 5 of D2-USER-M, which simplify this and other functions. The IBox instructions are supported by the D2-250-1, D2-260 and D2-262 CPUs.



NOTE: Be careful not to do a multiple number conversion on a value. For example, if you are using the pointer method to get the analog value, it is in BCD and must be converted to binary. However, if you are using the conventional method of reading analog and are masking the first twelve bits, then it is already in binary and no conversion using the BIN instruction is needed.

