

Changing Programs

In This Chapter. . . .

- Displaying a Program
 - Finding a Specific Instruction
 - Finding a Specific Address
 - Changing an Instruction
 - Inserting an Instruction
 - Inserting an END Statement
 - Deleting an Instruction
-

Displaying a Program

Since the Handheld displays the mnemonic instructions, you can step through the individual program instructions. If the CPU is in the RUN mode, the status of the instruction is also displayed in the status display area.

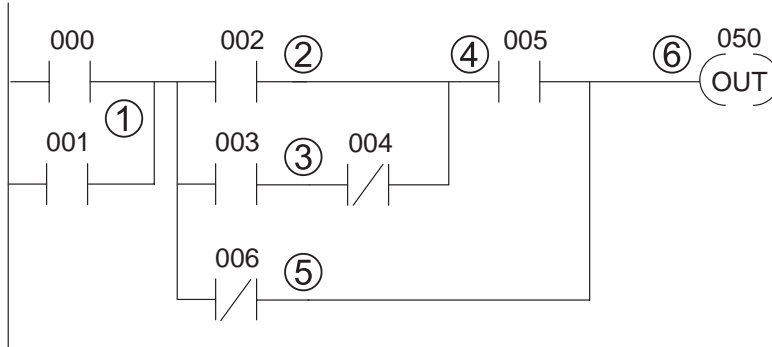

Mnemonic Listing and Addresses

ADDRESS	INSTRUCTION	DESCRIPTION
0000	STR 000	Starts branch 1 with 000
0001	OR 001	Joins 001 in parallel with 000
0002	STR 002	Starts branch 2 with 002
0003	STR 003	Starts branch 3 with 003
0004	ANDN 004	Joins 004 (NOT) with 003
0005	ORSTR	Joins branches 2 and 3
0006	AND 005	Starts branch 4 with 005
0007	ORN 006	Joins 006 (NOT) in parallel with 005
0008	ANDSTR	Joins branches 4 and 5 with 1-3
0009	OUT 050	Stores the output and finishes the network
0010	END	Ends the program

Press SHF and NXT to display the beginning of the program



Displays the first address

Use PRV or NXT to scroll through the program

NXT

In Run Mode, On/Off status is displayed

0000		0	4	0	4
ADDRESS/DATA		(AND)	(OUT)	(MCS)	(ADR)
ON/OFF RUN BATT		1	5	1	5
		(OR)	(TMR)	(MCR)	(SHF)
PWR CPU		2	6	2	6
		(STR)	(CNT)	(SET)	(DATA)
		3	7	3	7
		(NOT)	(SR)	(RST)	(REG)

NXT

0001		0	4	0	4
ADDRESS/DATA		(AND)	(OUT)	(MCS)	(ADR)
ON/OFF RUN BATT		1	5	1	5
		(OR)	(TMR)	(MCR)	(SHF)
PWR CPU		2	6	2	6
		(STR)	(CNT)	(SET)	(DATA)
		3	7	3	7
		(NOT)	(SR)	(RST)	(REG)

PRV

0000		0	4	0	4
ADDRESS/DATA		(AND)	(OUT)	(MCS)	(ADR)
ON/OFF RUN BATT		1	5	1	5
		(OR)	(TMR)	(MCR)	(SHF)
PWR CPU		2	6	2	6
		(STR)	(CNT)	(SET)	(DATA)
		3	7	3	7
		(NOT)	(SR)	(RST)	(REG)

Press CLR or NXT to toggle between the address and instruction display

CLR

0.0.0.0		0	4	0	4
ADDRESS/DATA		(AND)	(OUT)	(MCS)	(ADR)
ON/OFF RUN BATT		1	5	1	5
		(OR)	(TMR)	(MCR)	(SHF)
PWR CPU		2	6	2	6
		(STR)	(CNT)	(SET)	(DATA)
		3	7	3	7
		(NOT)	(SR)	(RST)	(REG)

Finding a Specific Instruction

If you do not want to scroll through the program, you can use the Search feature to automatically search for an instruction. The following example shows the instructions, addresses, and corresponding Handheld displays for a small program.

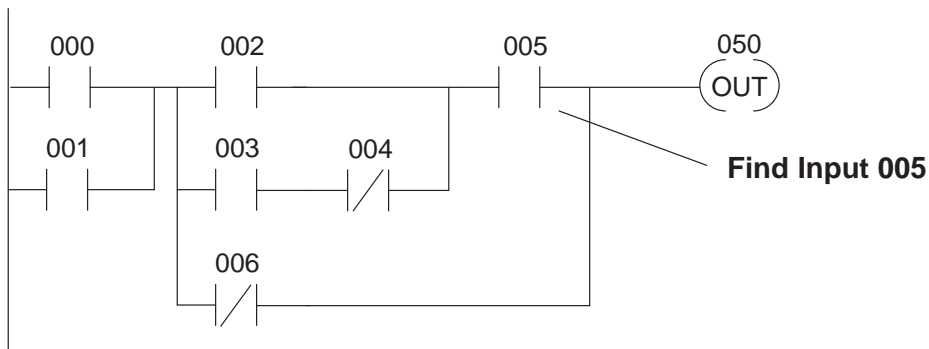

Mnemonic Listing and Addresses

ADDRESS	INSTRUCTION	DESCRIPTION
0000	STR 000	Starts branch 1 with 000
0001	OR 001	Joins 001 in parallel with 000
—	—	—
0006	AND 005	Starts branch 4 with 005
—	—	—
0010	END	Ends the program

Search for the instruction reference

SHF 5 SCH

Displays the address where the instruction is located

0.0.0.6

ADDRESS/DATA 0 (AND) 4 (OUT) 0 (MCS) 4 (ADR)

ON/OFF RUN BATT 1 (OR) 5 (TMR) 1 (MCR) 5 (SHF)

2 (STR) 6 (CNT) 2 (SET) 6 (DATA)

PWR CPU 3 (NOT) 7 (SR) 3 (RST) 7 (REG)

You can also specify how the reference is used (All outputs require the additional key to indicate how the point is used.)

OUT SHF 5 0 SCH

Displays the address where the instruction is located

0.0.0.9

ADDRESS/DATA 0 (AND) 4 (OUT) 0 (MCS) 4 (ADR)

ON/OFF RUN BATT 1 (OR) 5 (TMR) 1 (MCR) 5 (SHF)

2 (STR) 6 (CNT) 2 (SET) 6 (DATA)

PWR CPU 3 (NOT) 7 (SR) 3 (RST) 7 (REG)

Finding a Specific Address

You can also search for a specific address. The following example shows the instructions, addresses, and corresponding Handheld displays for a small program.

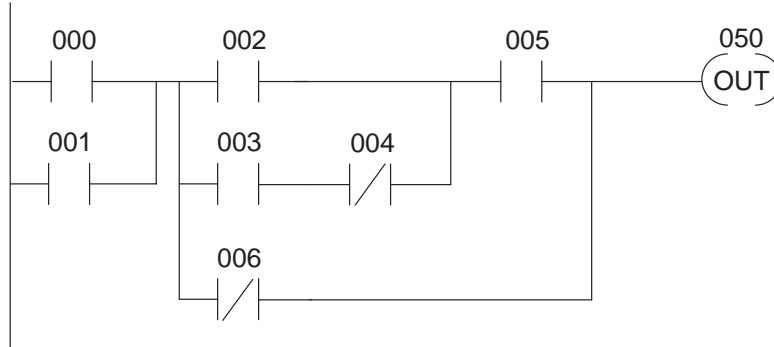

Mnemonic Listing and Addresses

ADDRESS	INSTRUCTION	DESCRIPTION
0000	STR 000	Starts branch 1 with 000
0001	OR 001	Joins 001 in parallel with 000
—	—	—
—	—	—
0006	AND 005	Starts branch 4 with 005
—	—	—
—	—	—
0010	END	Ends the program

Search for the address

SHF 6 NXT

0.0.0.6

ADDRESS/DATA

0	4	0	4
(AND)	(OUT)	(MCS)	(ADR)
1	5	1	5
(OR)	(TMR)	(MCR)	(SHF)
2	6	2	6
(STR)	(CNT)	(SET)	(DATA)
3	7	3	7
(NOT)	(SR)	(RST)	(REG)

ON/OFF RUN BATT

PWR CPU

Changing an Instruction

Sometimes you need to change an instruction. For example, you may want to use a different input or output point than the one originally entered into the program. The following example shows the instructions, addresses, and corresponding Handheld displays for a small program.

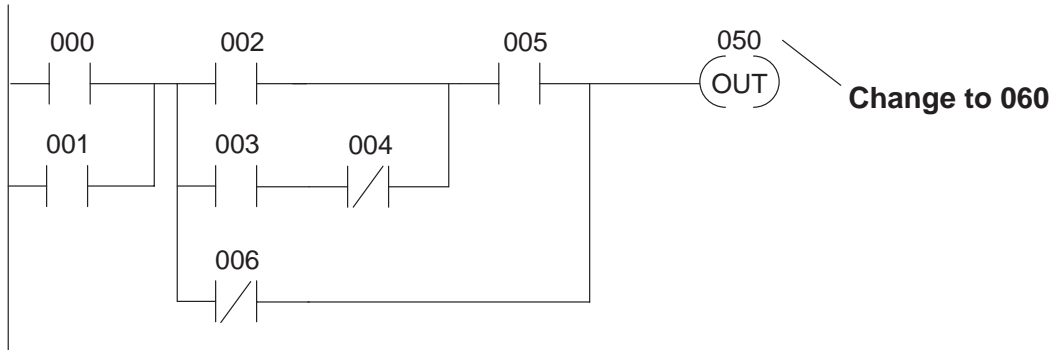

Mnemonic Listing and Addresses

ADDRESS	INSTRUCTION	DESCRIPTION
0000	STR 000	Starts branch 1 with 000
0001	OR 001	Joins 001 in parallel with 000
—	—	—
0006	AND 005	Starts branch 4 with 005
—	—	—
0009	OUT 060	Stores the output and finishes the network
0010	END	Ends the program

Search for the address

SHF 9 NXT

0.0.0.9

	0 <input type="button" value="AND"/>	4 <input type="button" value="OUT"/>	0 <input type="button" value="MCS"/>	4 <input checked="" type="button" value="ADR"/>
ADDRESS/DATA	1 <input type="button" value="OR"/>	5 <input type="button" value="TMR"/>	1 <input type="button" value="MCR"/>	5 <input type="button" value="SHF"/>
ON/OFF RUN BATT	2 <input type="button" value="STR"/>	6 <input type="button" value="CNT"/>	2 <input type="button" value="SET"/>	6 <input type="button" value="DATA"/>
PWR CPU	3 <input type="button" value="NOT"/>	7 <input type="button" value="SR"/>	3 <input type="button" value="RST"/>	7 <input type="button" value="REG"/>

Change the instruction

OUT SHF 6 0 ENT

060

	0 <input type="button" value="AND"/>	4 <input checked="" type="button" value="OUT"/>	0 <input type="button" value="MCS"/>	4 <input type="button" value="ADR"/>
ADDRESS/DATA	1 <input type="button" value="OR"/>	5 <input type="button" value="TMR"/>	1 <input type="button" value="MCR"/>	5 <input checked="" type="button" value="SHF"/>
ON/OFF RUN BATT	2 <input type="button" value="STR"/>	6 <input type="button" value="CNT"/>	2 <input type="button" value="SET"/>	6 <input type="button" value="DATA"/>
PWR CPU	3 <input type="button" value="NOT"/>	7 <input type="button" value="SR"/>	3 <input type="button" value="RST"/>	7 <input type="button" value="REG"/>

(Display before ENT is pressed)

Inserting an Instruction

Use the INSERT feature to add an instruction to the program. Insert adds an instruction *before* the instruction being displayed, so make sure you are at the correct program address. Once you've inserted the new instruction, the remaining addresses increment. The following example shows the instructions, addresses, and corresponding Handheld displays for a small program.

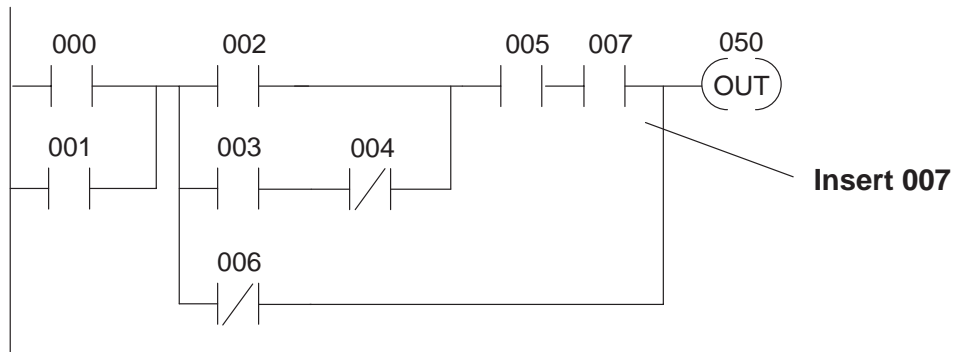

Mnemonic Listing and Addresses

ADDRESS	INSTRUCTION	DESCRIPTION
0000	STR 000	Starts branch 1 with 000
—	—	—
0006	AND 005	Starts branch 4 with 005
	Insert AND 007	Adds 007 in series with 005
0007	ORN 006	Joins 006 (NOT) in parallel with 005
—	—	—
0010	END	Ends the program

Search for the address

SHF 7 NXT

0.0.0.7

0	4	0	4
AND	OUT	MCS	ADR
1	5	1	5
OR	TMR	MCR	SHF
ON/OFF	RUN	BATT	
2	6	2	6
STR	CNT	SET	DATA
PWR	CPU		
3	7	3	7
NOT	SR	RST	REG

Insert the new instruction

AND SHF 7 INS NXT

(Display before NXT is pressed)

i 007

0	4	0	4
AND	OUT	MCS	ADR
1	5	1	5
OR	TMR	MCR	SHF
ON/OFF	RUN	BATT	
2	6	2	6
STR	CNT	SET	DATA
PWR	CPU		
3	7	3	7
NOT	SR	RST	REG

Inserting an END Statement

There may be times when you need to insert an END statement (*before* an address) in the program. This is commonly done when you only want to check a portion of the program during machine startup or troubleshooting. You use the INSERT feature, but since the Handheld does not have an END key, special keystrokes are required.

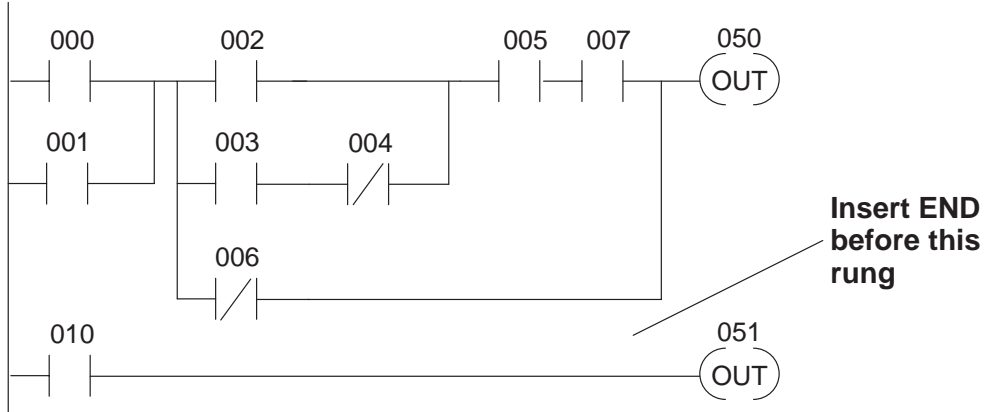

Mnemonic Listing and Addresses

ADDRESS	INSTRUCTION	DESCRIPTION
0000	STR 000	Starts branch 1 with 000
—	—	—
0006	AND 005	Starts branch 4 with 005
	Insert END	Ends the program
0008	ORN 006	Joins 006 (NOT) in parallel with 005
—	—	—
0013	END	Ends the program

Search for the address

SHF 8 NXT

0.0.0.8

0	4	0	4
(AND)	(OUT)	(MCS)	(ADR)
1	5	1	5
(OR)	(TMR)	(MCR)	(SHF)
2	6	2	6
(STR)	(CNT)	(SET)	(DATA)
3	7	3	7
(NOT)	(SR)	(RST)	(REG)

ADDRESS/DATA ON/OFF RUN BATT PWR CPU

Insert the END statement

CLR SHF INS NXT

(Display before NXT is pressed)

i

0	4	0	4
(AND)	(OUT)	(MCS)	(ADR)
1	5	1	5
(OR)	(TMR)	(MCR)	(SHF)
2	6	2	6
(STR)	(CNT)	(SET)	(DATA)
3	7	3	7
(NOT)	(SR)	(RST)	(REG)

ADDRESS/DATA ON/OFF RUN BATT PWR CPU

Deleting an Instruction

Use the DELETE feature to remove an instruction from the program. Delete removes the instruction being displayed, so make sure you are at the correct program address. Once you've deleted the instruction, the remaining addresses decrement. The following example shows the instructions, addresses, and corresponding Handheld displays for a small program.

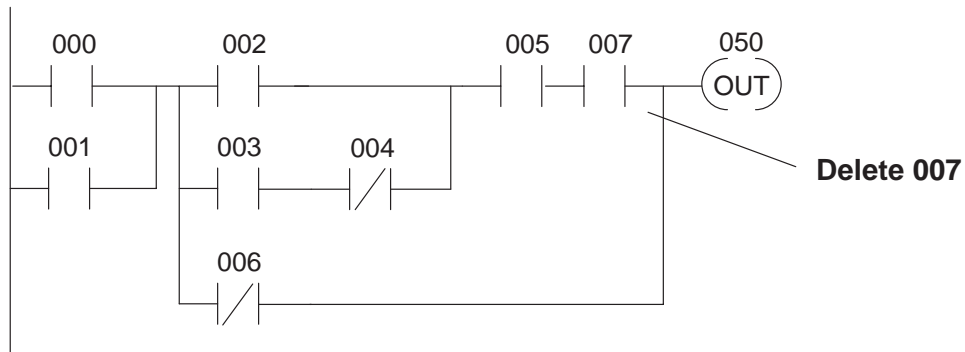

Mnemonic Listing and Addresses

ADDRESS	INSTRUCTION	DESCRIPTION
0000	STR 000	Starts branch 1 with 000
—	—	—
Delete 0006	AND 005	Starts branch 4 with 005
Delete 0007	AND 007	Adds X7 in series with X5
0008	ORN 006	Joins 006 (NOT) in parallel with 005
—	—	—
0011	END	Ends the program

Search for the address

SHF 7 NXT

0.0.0.7

0	4	0	4
(AND)	(OUT)	(MCS)	(ADR)
1	5	1	5
(OR)	(TMR)	(MCR)	(SHF)
2	6	2	6
(STR)	(CNT)	(SET)	(DATA)
3	7	3	7
(NOT)	(SR)	(RST)	(REG)

ADDRESS/DATA ON/OFF RUN BATT PWR CPU

Delete the instruction

DEL PRV

(Display before PRV is pressed)

d 007

0	4	0	4
(AND)	(OUT)	(MCS)	(ADR)
1	5	1	5
(OR)	(TMR)	(MCR)	(SHF)
2	6	2	6
(STR)	(CNT)	(SET)	(DATA)
3	7	3	7
(NOT)	(SR)	(RST)	(REG)

ADDRESS/DATA ON/OFF RUN BATT PWR CPU