

Instruction Set

In This Chapter. . . .

- Boolean Instructions
 - Comparative Boolean Instructions
 - Timer, Counter, and Shift Register Instructions
 - Accumulator Load and Output Instructions
 - Accumulator Logic Instructions
 - Math Instructions
 - Bit Operation Instructions
 - Number Conversion Instructions
 - Program Control Instructions
 - Network Instructions
 - Message Instructions
-

Introduction

The DL305 CPUs offer a wide variety of instructions to perform many different types of operations. This chapter shows you how to use these individual instructions. The following table provides a quick reference listing of the instruction mnemonic and the page(s) defining the instruction. (The mnemonics are very similar to the instruction names and should be easy to become familiar with in a short time.) For example STR NOT (Comparative) is the mnemonic for Store Not Equal. Each instruction definition will show in parentheses the keystrokes used to enter the instruction.

There are two ways to quickly find the instruction you need.

- If you know the instruction category (Boolean, Comparative Boolean, etc.) just use the header at the top of the page to find the pages that discuss the instructions in that category.
- If you know the individual instruction mnemonic, use the following table to find the page that discusses the instruction.

The DL330 and DL340 instructions sets are very similar. However, the DL330P instruction set has several differences. Some of the instructions in this chapter will be labeled “DL330/DL340 Only.” There may be an equivalent instruction for the DL330P CPU, but it may also work slightly differently. The DL330P instructions that operate differently from these instructions are discussed in Chapter 12. Make sure you review the instructions carefully to make sure you can use the instruction with your CPU.

Instruction	Page
ADD (F71)	11-34
AND	11-10
AND (Comparative)	11-21
AND NOT	11-10
AND NOT (Comparative)	11-21
AND NOT T/C	11-11, 11-12
AND STR	11-13
AND T/C	11-11, 11-12
BCD (F86)	11-48
BIN (F85)	11-47
CMP (F70)	11-32
CNT	11-23
DAND (F75)	11-30
DECO (F82)	11-46
DIV (F74)	11-40
DOR (F76)	11-31
DOUT (F60)	11-25
DOUT1 (F61)	11-26
DOUT2 (F62)	11-27
DOUT3 (F63)	11-28
DOUT5 (F65)	11-29
DSTR (F50)	11-25
DSTR1 (F51)	11-26
DSTR2 (F52)	11-27
DSTR3 (F53)	11-28
DSTR5 (F55)	11-29
ENCO (F83)	11-44
FAULT (F20)	11-56

Instruction	Page
INV (F84)	11-49
MCR	11-50
MCS	11-50
MUL (F73)	11-38
OR	11-7
OR (Comparative)	11-20
OR NOT	11-7
OR NOT (Comparative)	11-20
OR NOT T/C	11-8, 11-9
OR STR	11-13
OR T/C	11-8, 11-9
OUT	11-15
RST	11-16
RX (F952)	11-52
SET	11-16
SET OUT	11-17
SET OUT RST	11-18
SHFL (F82)	11-42
SHFR (F80)	11-43
SR	11-24
STR	11-4
STR (Comparative)	11-19
STR NOT	11-4
STR NOT (Comparative)	11-19
STR NOT T/C	11-5, 11-6
STR T/C	11-5, 11-6
SUB (F72)	11-36
TMR	11-22
WX (F953)	11-54

NOTE: See Chapter 12 for RLL *PLUS* instructions.

Boolean Instructions

Store (STR)

The Store instruction begins a new rung or additional branch in a rung with a normally open contact. Status of the contact will be the same state as the associated image register point or memory location.

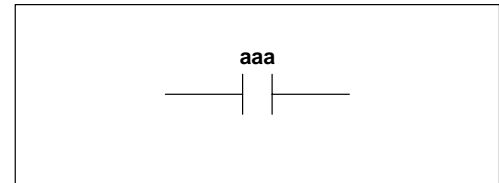

Store Not (STR NOT)

The Store Not instruction begins a new rung or additional branch in a rung with a normally closed contact. Status of the contact will be opposite the state of the associated image register point or memory location.

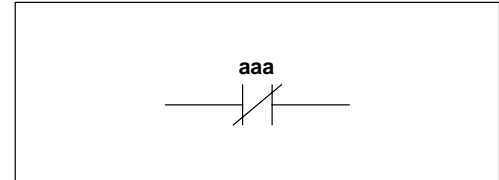

Data Type	D3-330 Range	D3-340 Range	D3-330P Range
	aaa	aaa	aaa
Inputs / Outputs	000-167 700-767	000-177 700-767	000-167 700-767
Control Relays	160-373	160-373 1000-1067	160-174 200-77
Special Control Relays	374-377 770-777	374-377 770-777 1074-1077	175-177 770-777
Shift Register Bits	400-577	400-577	—

In the following Store example, when input 000 is on, output 010 will energize.

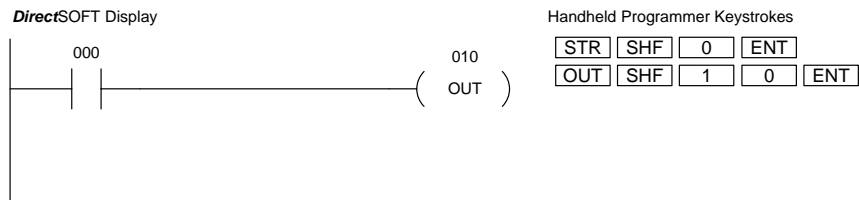

In the following Store Not example, when input 000 is off output 010 will energize.

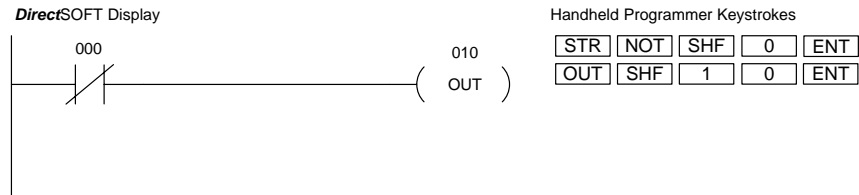

**Store Timer
 (STR TMR)
 DL330/340 Only**

The Store Timer instruction begins a new rung or additional branch in a rung with a normally open timer contact. The timer contact T aaa will be on when the timer current value is \geq the preset value of the associated timer.

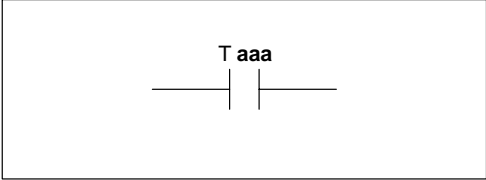

**Store Not Timer
 (STR NOT TMR)
 DL330/340 Only**

The Store Not Timer instruction begins a new rung or additional branch in a rung with a normally closed timer contact. The timer contact T aaa will be on when the timer current value is $<$ the preset value of the associated timer.

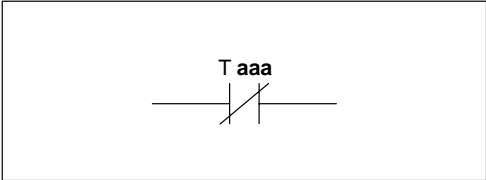

Data Type	D3-330 Range	D3-340 Range	D3-330P Range*
	aaa	aaa	aaa
Timer T	600-677	600-677	—

* See Chapter 12 for similar RLL PLUS instructions

In the following Store Timer example, when the current value in timer 600 is \geq the preset value output 017 will energize.

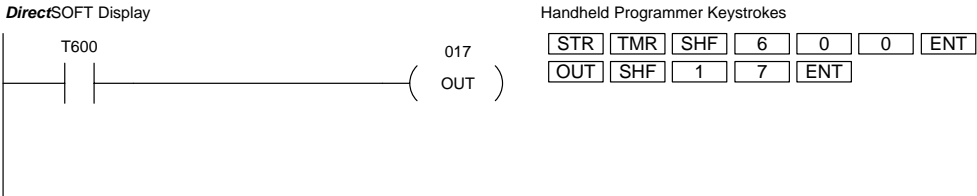

In the following Store Not Timer example, when the current value in timer 600 is $<$ the preset value output 017 will energize.

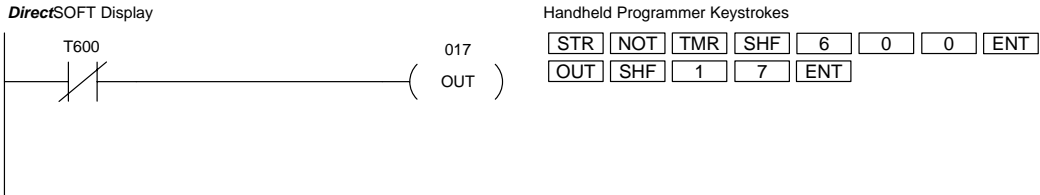

**Store Counter
(STR CNT)
DL330/340 Only**

The Store Counter instruction begins a new rung or additional branch in a rung with a normally open counter contact. The counter contact C aaa will be on when the counter current value \geq the preset value of the associated counter.

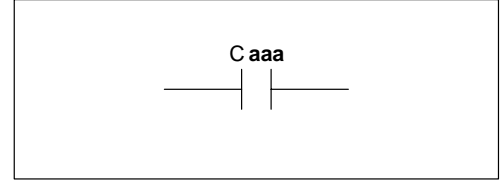

**Store Not Counter
(STR NOT CNT)
DL330/340 Only**

The Store Not Counter instruction begins a new rung or additional branch in a rung with a normally closed counter contact. The counter contact C aaa will be on when the counter current value is $<$ the preset value of the associated counter.

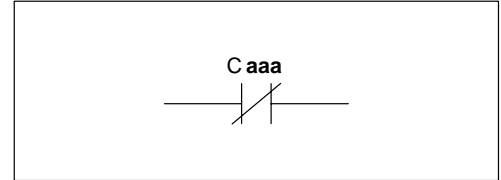

Data Type	D3-330 Range	D3-340 Range	D3-330P Range*
	aaa	aaa	aaa
Counter C	600-677	600-677	—

* See Chapter 12 for similar RLL^{PLUS} instructions

In the following Store Counter example, when the current value in counter 602 is \geq the preset value output 015 will energize.

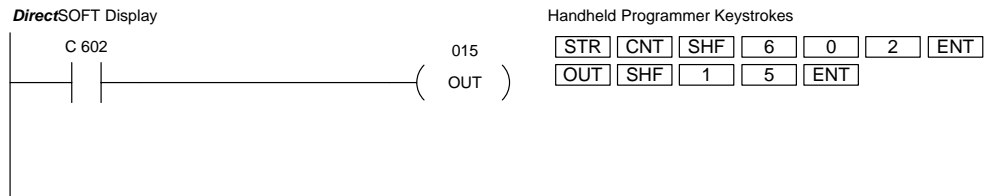

In the following Store Not Counter example, when the current value in counter 602 is $<$ the preset value output 015 will energize.

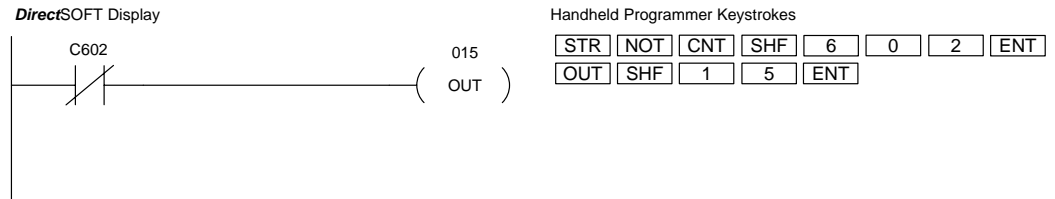

**Or
(OR)**

The Or instruction logically ors a normally open contact in parallel with another contact in a rung. The status of the contact will be the same state as the associated image register point or memory location.

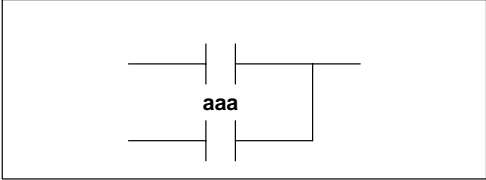

**Or Not
(OR NOT)**

The Or Not instruction logically ors a normally closed contact in parallel with another contact in a rung. The status of the contact will be opposite the state of the associated image register point or memory location.

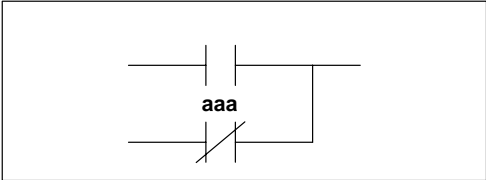

Data Type	D3-330 Range	D3-340 Range	D3-330P Range
	aaa	aaa	aaa
Inputs / Outputs	000-167 700-767	000-177 700-767	000-167 700-767
Control Relays	160-373	160-373 1000-1067	160-174 200-77
Special Control Relays	374-377 770-777	374-377 770-777 1074-1077	175-177 770-777
Shift Register Bits	400-577	400-577	—

In the following Or example, when input 000 or 001 is on output 010 will energize.

DirectSOFT Display

Handheld Programmer Keystrokes

STR	SHF	0	ENT	
OR	SHF	1	ENT	
OUT	SHF	1	0	ENT

In the following Or Not example, when input 000 is on or 001 is off output 010 will energize.

DirectSOFT Display

Handheld Programmer Keystrokes

STR	SHF	0	ENT	
OR	NOT	SHF	1	ENT
OUT	SHF	1	0	ENT

**Or Timer
(OR TMR)
DL330/340 Only**

The Or Timer instruction logically ors a normally open timer contact in parallel with another contact in a rung. The timer contact T aaa will be on when the timer current value is \geq the preset value of the associated timer.

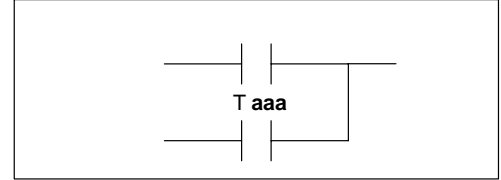

**Or Not Timer
(OR NOT TMR)
DL330/340 Only**

The Or Not Timer instruction logically ors a normally closed timer contact in parallel with another contact in a rung. The timer contact T aaa will be on when the timer current value is $<$ the preset value of the associated timer.

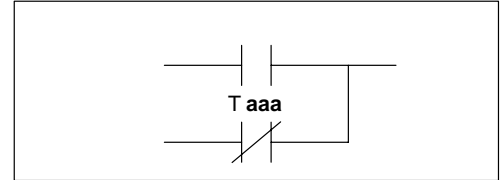

Data Type	D3-330 Range	D3-340 Range	D3-330P Range*
	aaa	aaa	aaa
Timer	T	600-677	600-677

* See Chapter 12 for similar RLL^{PLUS} instructions

In the following Or Timer example, when input 000 is on or the current value in T600 is \geq the preset value output 010 will energize.

DirectSOFT Display

Handheld Programmer Keystrokes

```

[STR] [SHF] [0] [ENT]
[OR] [TMR] [SHF] [6] [0] [0] [ENT]
[OUT] [SHF] [1] [0] [ENT]
                    
```

In the following Or Not Timer example, when input 000 is on or the current value in T600 is $<$ the preset value output 010 will energize.

DirectSOFT Display

Handheld Programmer Keystrokes

```

[STR] [SHF] [0] [ENT]
[OR] [NOT] [TMR] [SHF] [6] [0] [0] [ENT]
[OUT] [SHF] [1] [0] [ENT]
                    
```

**Or Counter
(OR CNT)
DL330/340 Only**

The Or Counter instruction logically ors a normally open counter contact in parallel with another contact in a rung. The counter contact C aaa will be on when the counter current value is \geq the preset value of the associated counter.

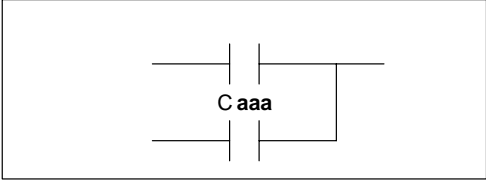

**Or Not Counter
(OR NOT CNT)
DL330/340 Only**

The Or Not Counter instruction logically ors a normally closed counter contact in parallel with another contact in a rung. The counter contact C aaa will be on when the counter current value is $<$ the preset value of the associated counter.

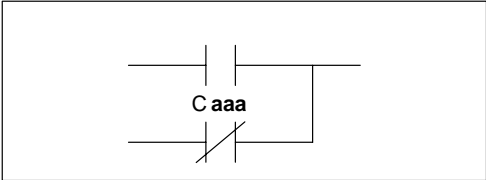

Data Type	D3-330 Range	D3-340 Range	D3-330P Range*
	aaa	aaa	aaa
Counter C	600-677	600-677	—

* See Chapter 12 for similar RLL^{PLUS} instructions

In the following Or Counter example, when input 007 is on or the current value in C610 is \geq the preset value output 025 will energize.

DirectSOFT Display

Handheld Programmer Keystrokes

STR SHF 7 ENT

OR CNT SHF 6 1 0 ENT

OUT SHF 2 5 ENT

In the following Or Not Counter example, when input location 007 is on or the current value in C610 is $<$ the preset value output 025 will energize.

DirectSOFT Display

Handheld Programmer Keystrokes

STR SHF 7 ENT

OR NOT CNT SHF 6 1 0 ENT

OUT SHF 2 5 ENT

And (AND)

The And instruction logically ands a normally open contact in series with another contact in a rung. The status of the contact will be the same state as the associated image register point or memory location.

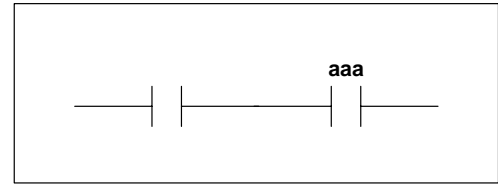

And Not (AND NOT)

The And Not instruction logically ands a normally closed contact in series with another contact in a rung. The status of the contact will be opposite the state of the associated image register point or memory location.

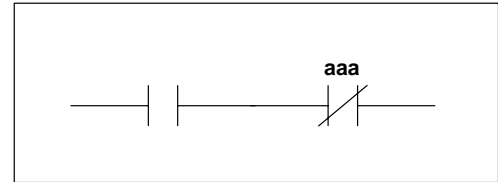

Data Type	D3-330 Range	D3-340 Range	D3-330P Range
	aaa	aaa	aaa
Inputs / Outputs	000-167 700-767	000-177 700-767	000-167 700-767
Control Relays	160-373	160-373 1000-1067	160-174 200-77
Special Control Relays	374-377 770-777	374-377 770-777 1074-1077	175-177 770-777
Shift Register Bits	400-577	400-577	—

In the following And example, when input 000 and 001 is on output 010 will energize.

DirectSOFT Display

Handheld Programmer Keystrokes

STR	SHF	0	ENT	
AND	SHF	1	ENT	
OUT	SHF	1	0	ENT

In the following And Not example, when input 000 is on and 001 is off output 010 will energize.

DirectSOFT Display

Handheld Programmer Keystrokes

STR	SHF	0	ENT	
AND	NOT	SHF	1	ENT
OUT	SHF	1	0	ENT

**And Timer
 (AND TMR)
 DL330/340 Only**

The And Timer instruction logically ands a normally open timer contact in series with another contact in a rung. The timer contact T aaa will be on when the timer current value \geq the preset value of the associated timer.

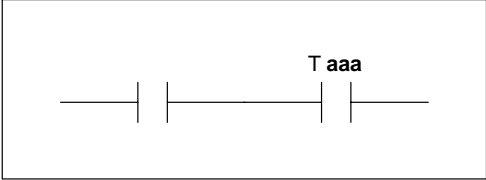

**And Not Timer
 (AND NOT TMR)
 DL330/340 Only**

The And Not Timer instruction logically ands a normally closed timer contact in series with another contact in a rung. The timer contact T aaa will be on when the timer current value is $<$ the preset value of the associated timer.

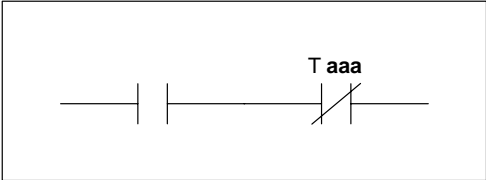

Data Type	D3-330 Range	D3-340 Range	D3-330P Range*
	aaa	aaa	aaa
Timer T	600-677	600-677	—

* See Chapter 12 for similar RLL^{PLUS} instructions

In the following And Timer example, when input 000 is on and the current value in timer 604 is \geq the preset value output 050 will energize.

DirectSOFT Display

Handheld Programmer Keystrokes

STR SHF 0 ENT
 AND TMR SHF 6 0 4 ENT
 OUT SHF 5 0 ENT

In the following And Not Timer example, when input 000 is on and the current value in timer 604 is $<$ the preset value output 050 will energize.

DirectSOFT Display

Handheld Programmer Keystrokes

STR SHF 0 ENT
 AND NOT TMR SHF 6 0 4 ENT
 OUT SHF 5 0 ENT

**And Counter
(AND CNT)
DL330/340 Only**

The And Counter instruction logically ands a normally open counter contact in series with another contact in a rung. The counter contact C aaa will be on when the counter current value is \geq the preset value of the associated counter.

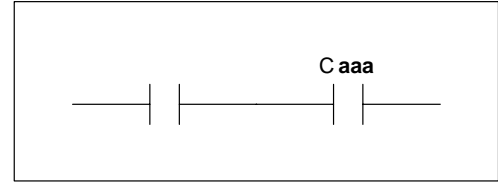

**And Not Counter
(AND NOT CNT)
DL330/340 Only**

The And Not Counter instruction logically ands a normally closed counter contact in series with another contact in a rung. The counter contact C aaa will be on when the counter current value is $<$ the preset value of the associated counter.

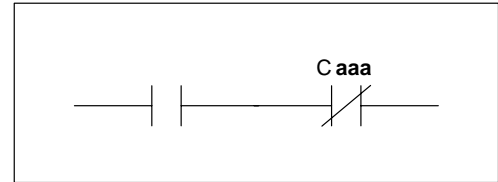

Data Type	D3-330 Range	D3-340 Range	D3-330P Range
	aaa	aaa	aaa
Counter C	600-677	600-677	—

* See Chapter 12 for similar RLL^{PLUS} instructions

In the following And Counter example, when input 002 is on and the current value in counter 602 is \geq the preset value output 050 will energize.

DirectSOFT Display

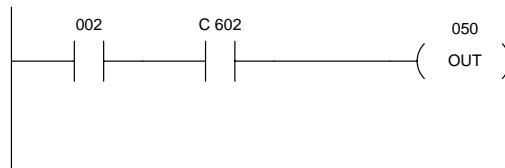

Handheld Programmer Keystrokes

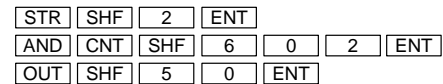

In the following And Not Counter example, when input 002 is on and the current value in counter 602 is $<$ the preset value output 050 will energize.

DirectSOFT Display

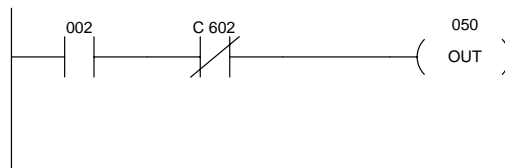

Handheld Programmer Keystrokes

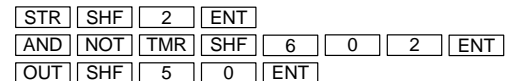

**And Store
 (AND STR)**

The And Store instruction logically ands two branches of a rung in series. Both branches must begin with the Store instruction.

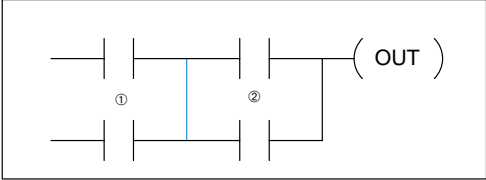

**Or Store
 (OR STR)**

The Or Store instruction logically ors two branches of a rung in parallel. Both branches must begin with the Store instruction.

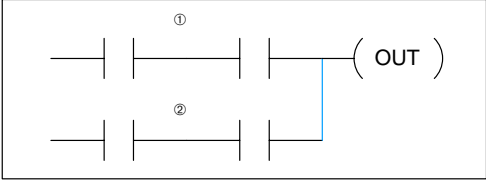

In the following And Store example, the branch consisting of contacts 000 and 002 have been anded with the branch consisting of contacts 001 and 003.

DirectSOFT Display

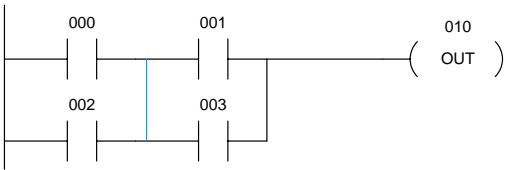

Handheld Programmer Keystrokes

- STR SHF 0 ENT
- OR SHF 2 ENT
- STR SHF 1 ENT
- OR SHF 3 ENT
- AND STR ENT
- OUT SHF 1 0 ENT

In the following Or Store example, the branch consisting of 000 and 001 have been ored with the branch consisting of 002 and 003.

DirectSOFT Display

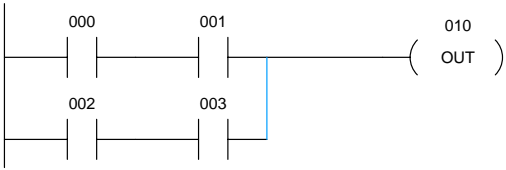

Handheld Programmer Keystrokes

- STR SHF 0 ENT
- AND SHF 1 ENT
- STR SHF 2 ENT
- AND SHF 3 ENT
- OR STR ENT
- OUT SHF 1 0 ENT

There are limits to what you can enter with these simple boolean instructions. This is because the DL305 CPUs use an 8-level stack to evaluate the various logic elements. The stack is a temporary storage area that helps solve the logic for the rung. Each time you enter a Store instruction, the instruction is placed on the top of the stack. Any other instructions on the stack are pushed down a level. The And, Or, And Store, and Or Store instructions combine levels of the stack when they are encountered. Since the stack is only eight levels, an error will occur if the CPU encounters a rung that uses more than the eight levels of the stack.

The following example shows how the stack is used to solve simple boolean logic.

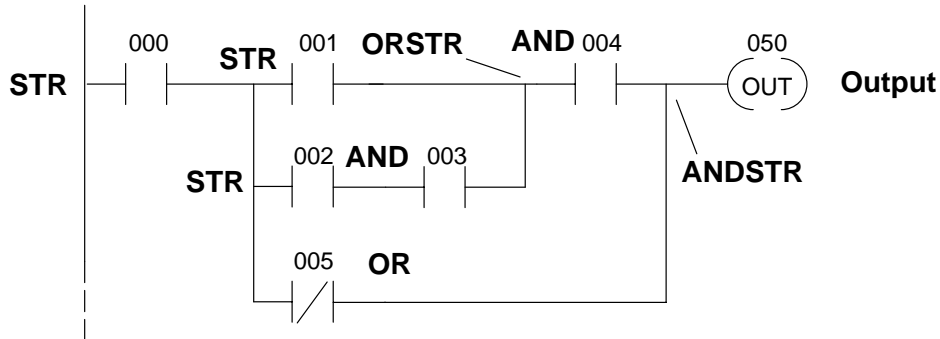

1 STR 000

1	STR 000
2	
3	
4	
5	
6	
7	
8	

2 STR 001

1	STR 001
2	STR 000
3	
4	
5	
6	
7	
8	

3 STR 002

1	STR 002
2	STR 001
3	STR 000
4	
5	
6	
7	
8	

4 AND 003

1	002 AND 003
2	STR 001
3	STR 000
4	
5	
6	
7	
8	

5 ORSTR

1	001 OR (002 AND 003)
2	STR 000
3	

⋮

8	
---	--

6 AND 004

1	004 AND [001 OR (002 AND 003)]
2	STR 000
3	

⋮

8	
---	--

7 OR 005

1	005 OR 004 AND [001 OR (002 AND 003)]
2	STR 000
3	

⋮

8	
---	--

8 ANDSTR

1	000 AND (005 OR 004) AND [001 OR (002 AND 003)]
2	
3	

⋮

8	
---	--

**Out
 (OUT)**

The Out instruction reflects the status of the rung (on/off) and outputs the discrete (on/off) state to the specified image register point or memory location. Multiple Out instructions referencing the same discrete location should not be used because only the last Out instruction in the program will control the physical output point.

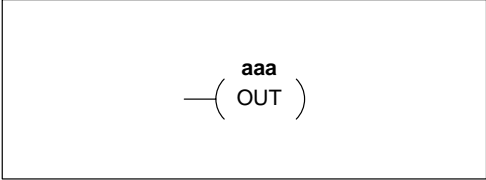

Data Type	D3-330 Range	D3-340 Range	D3-330P Range
	aaa	aaa	aaa
Outputs	000-167 700-767	000-177 700-767	000-167 700-767
Control Relays	160-373	160-373 1000-1067	160-174 200-77
Shift Register Bits	400-577	400-577	—

In the following Out example, when input 000 is on output 010 will energize.

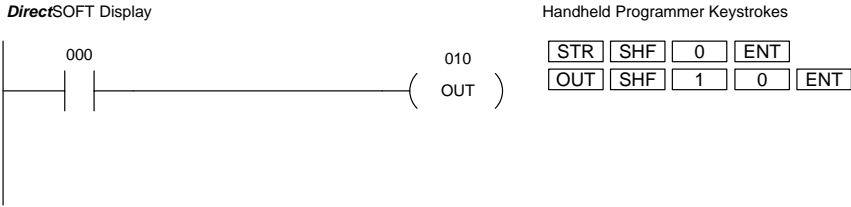

In the following Out example, two Out instructions using output 10 are used in the program. The status of output 010 being controlled by input 001 will override the instance of output 010 being controlled by input 000. The physical output would always be controlled by input 001.

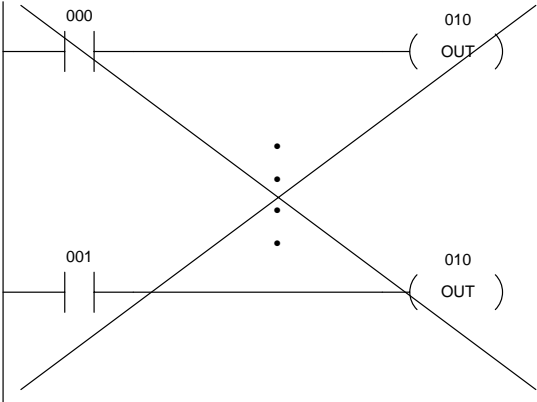

Set (SET)
DL330/340 Only

The Set instruction sets or turns on an output. Once the output is set it will remain on until it is reset using the Reset instruction. It is not necessary for the input controlling the Set instruction to remain on. The Set instruction is sometimes known as a latch. The Reset instruction is used to reset the output.

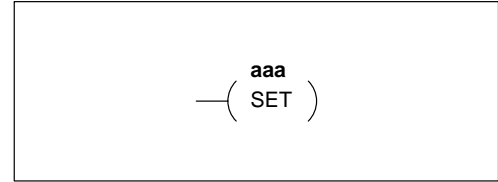

Reset (RST)
DL330/340 Only

The Reset instruction resets or turns off an output. Once the output is reset it is not necessary for the input to remain on. The Reset instruction is sometimes known as an unlatch instruction.

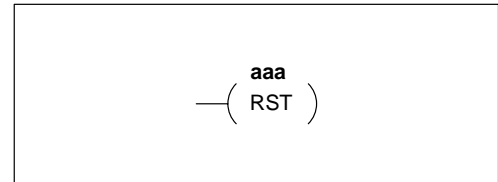

Data Type	D3-330 Range	D3-340 Range	D3-330P Range*
	aaa	aaa	aaa
Outputs	000-167 700-767	000-177 700-767	—
Control Relays	160-373	160-373 1000-1067	—
Shift Register Bits	400-577	400-577	—

* See Chapter 12 for similar RLL *PLUS* instructions

In the following Set example, when input 000 is on output 010 will be energized.

DirectSOFT Display



Handheld Programmer Keystrokes

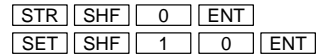

In the following Reset example, when input 001 is on output 010 will de-energize.

DirectSOFT Display

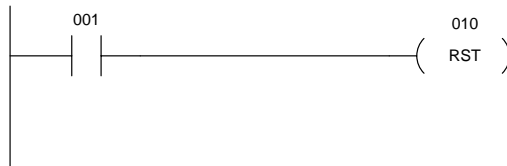

Handheld Programmer Keystrokes

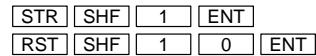

**Set Out
 (SET OUT)**

The Set Out instruction reflects the status of the rung (on/off) and outputs the discrete (on/off) state to the specified image register location. This instruction is similar to the Out instruction except the output disable coil (special relay 376) will not override and disable the output. Multiple Set Out instructions referencing the same discrete location should not be used because only the last Set Out instruction in the program will control the physical output point.

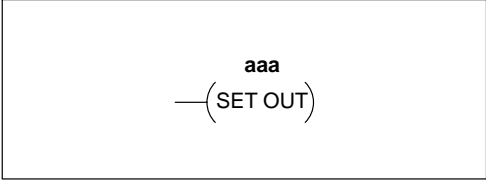

Data Type	D3-330 Range	D3-340 Range	D3-330P Range
	aaa	aaa	aaa
Outputs	000-167 700-767	000-177 700-767	000-167 700-767

In the following Set Out example, when input location 000 is on output 020 will energize. The output disable coil (special relay 376) will not override this output coil.

DirectSOFT Display



Handheld Programmer Keystrokes



Set Out Reset (SET OUT RST)

The Set Out Reset instruction is typically known as a one shot. When the input logic produces an off to on transition the output will turn on for one CPU scan.

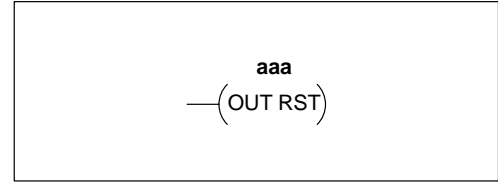

Data Type	D3-330 Range	D3-340 Range	D3-330P Range
	aaa	aaa	aaa
Outputs	000-167 700-767	000-177 700-767	000-167 700-767
Control Relays	160-373	160-373 1000-1067	160-174 200-77

In the following Set Out Reset example, when input 007 transitions from off to on, control relay 160 will energize for the remainder of the CPU scan.

DirectSOFT Display

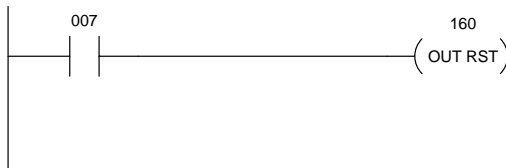

Handheld Programmer Keystrokes



Comparative Boolean Instructions

Store If Equal (STR) DL330/DL340 Only

The Store If Equal instruction begins a new rung or additional branch in a rung with a normally open comparative counter contact. The contact will be on if the specified counter CT aaa = B bbbb.

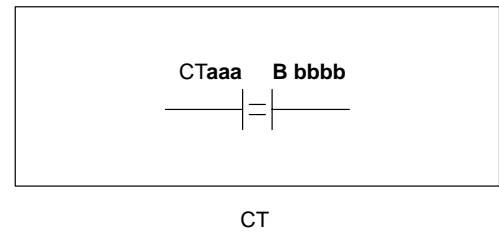

Store Not If Equal (STR NOT) DL330/DL340 Only

The Store Not If Equal instruction begins a new rung or additional branch in a rung with a normally closed comparative counter contact. The contact will be on if the specified counter CT aaa \neq B bbbb.

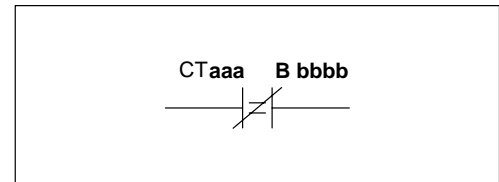

Operand Data Type	D3-330 Range		D3-340 Range		D3-330P Range*		
	B	aaa	bbbb	aaa	bbbb	aaa	bbbb
Counters CT		600-677	—	600-677	—	—	—
Data registers R		—	400-577	—	400-577 700-777	—	—
Constant K		—	0-9999	—	0-9999	—	—

* See Chapter 12 for similar RLL *PLUS* instructions

In the following Store If Equal example, when CT600 = 2510 output 012 will energize.

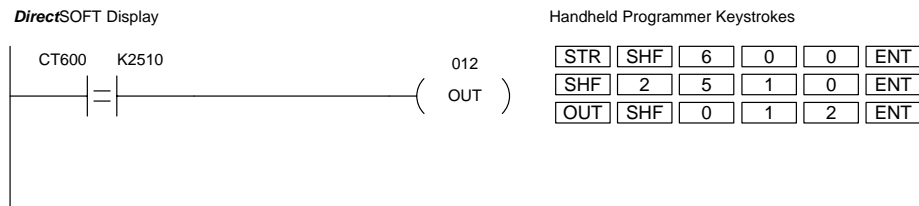

In the following Store Not If Equal example, when CT600 is \neq the value in R400 output 020 will energize.

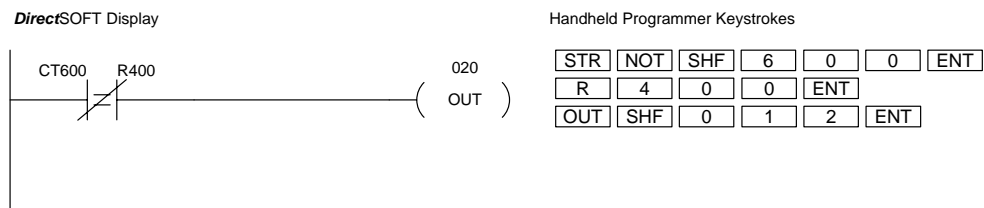

**Or If Equal
(OR)
DL330/DL340 Only**

The Or If Equal instruction connects a normally open comparative counter contact in parallel with another contact. The contact will be on if the specified counter CT aaa = B bbbb.

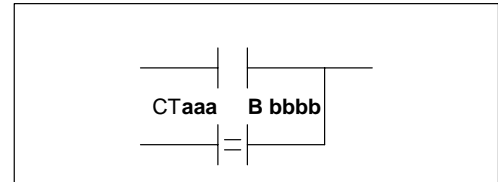

**Or Not If Equal
(OR NOT)
DL330/DL340 Only**

The Or Not If Equal instruction connects a normally closed comparative counter contact in parallel with another contact. The contact will be on if the specified counter CT aaa \neq B bbbb.

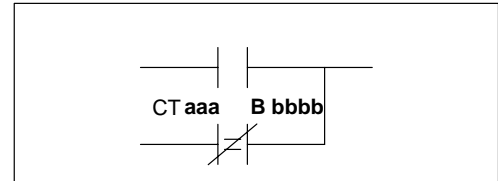

Operand Data Type		D3-330 Range		D3-340 Range		D3-330P Range*	
	B	aaa	bbbb	aaa	bbbb	aaa	bbbb
Counters	CT	600-677	—	600-677	—	—	—
Data registers	R	—	400-577	—	400-577 700-777	—	—
Constant	K	—	0-9999	—	0-9999	—	—

* See Chapter 12 for similar RLL *PLUS* instructions

In the following Or If Equal example, when input contact 001 is on or CT600 = 2510 output 012 will energize.

DirectSOFT Display

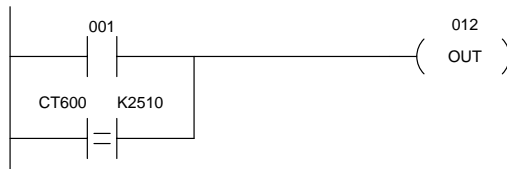

Handheld Programmer Keystrokes

STR	SHF	1	ENT				
OR	SHF	6	0	0	ENT		
SHF	2	5	1	0	ENT		
OUT	SHF	0	1	2	ENT		

In the following Or Not If Equal example, when input contact 001 is on or CT600 \neq the value in R400 output 012 will energize.

DirectSOFT Display

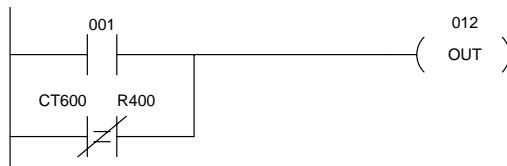

Handheld Programmer Keystrokes

STR	SHF	1	ENT				
OR	NOT	6	0	0	ENT		
R	4	0	0	ENT			
OUT	SHF	0	1	2	ENT		

And If Equal (AND)
DL330/DL340 Only

The And If Equal instruction connects a normally open comparative counter contact in series with another contact. The contact will be on if the specified counter CT aaa = B bbbb.

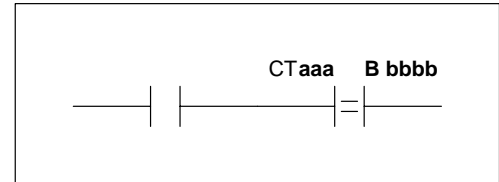

And Not If Equal (AND NOT)
DL330/DL340 Only

The And Not If Equal instruction connects a normally closed comparative counter contact in series with another contact. The contact will be on if the specified counter CT aaa \neq B bbbb.

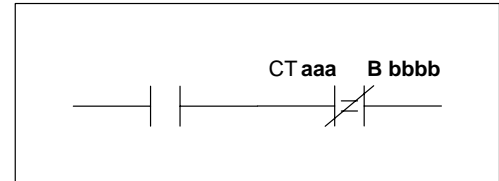

Operand Data Type	B	D3-330 Range		D3-340 Range		D3-330P Range*	
		aaa	bbbb	aaa	bbbb	aaa	bbbb
Counters	CT	600-677	—	600-677	—	—	—
Data registers	R	—	400-577	—	400-577 700-777	—	—
Constant	K	—	0-9999	—	0-9999	—	—

* See Chapter 12 for similar RLL *PLUS* instructions

In the following And If Equal example, when input contact 001 is on and CT600 = 2510 the contact will turn on and output 012 will energize.

DirectSOFT Display

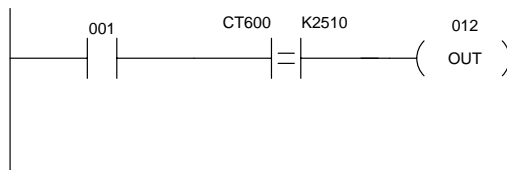

Handheld Programmer Keystrokes

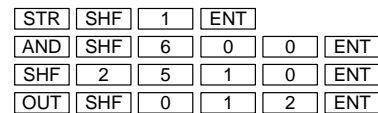

In the following And Not If Equal example, when input contact 001 is on and CT600 \neq the value in R400 output 012 will energize.

DirectSOFT Display

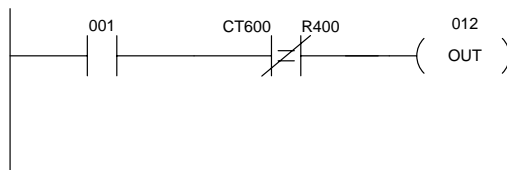

Handheld Programmer Keystrokes

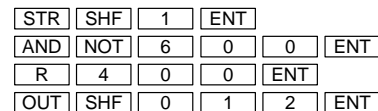

Timer, Counter, and Shift Register Instructions

Timer (TMR) DL330/DL340 Only

The Timer instruction provides a single input timer with a 0.1 second increment (0–999.9 seconds) in the normal operating mode, or a 0.01 second increment (0–99.99 seconds) in the fast timer mode when relay 770 is turned on. The timer will time up to 9999 and stop. It will reset to zero when the input is turned off. The discrete bit associated with the timer will be on when the current value is equal to or greater than the preset value.

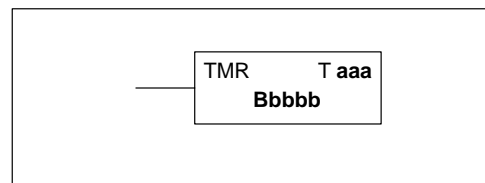

Operand Data Type	D3-330 Range		D3-340 Range		D3-330P Range	
	aaa	bbbb	aaa	bbbb	aaa	bbbb
Timers T	600-677	—	600-677	—	—	—
Data registers R	—	400-577	—	400-577 700-777	—	—
Constant K	—	0-9999	—	0-9999	—	—

* See Chapter 12 for similar RLL *PLUS* instructions

In the following Timer example, timer 600 will begin timing up when input 000 turns on. The timer bit associated with timer 600 will turn on when the current value in timer 600 is \geq the preset value K30 (3 seconds). When input 000 turns off the timer discrete bit and current value are reset.

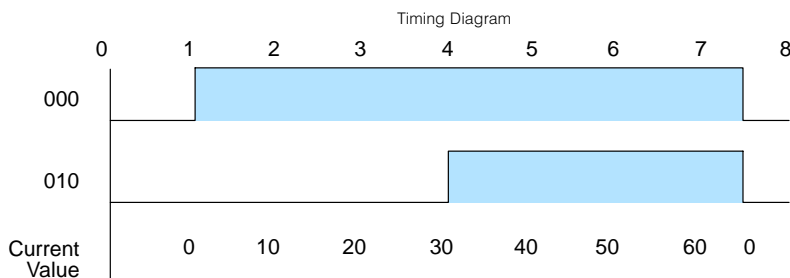
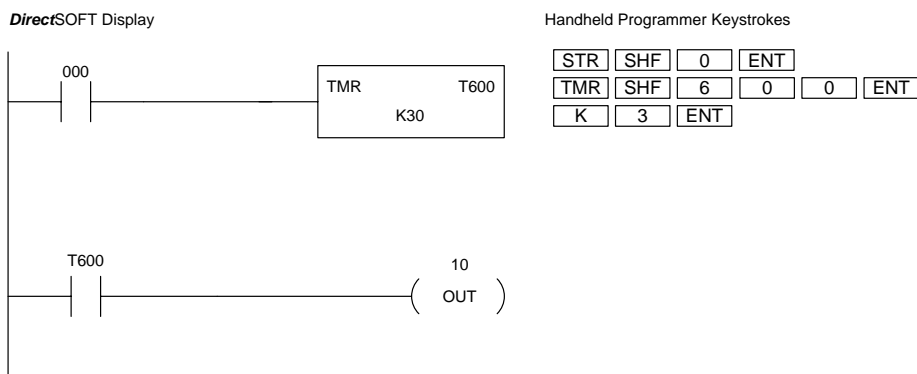

**Counter (CNT)
DL330/DL340 Only**

The Counter instruction provides a counter with a count and reset input. The range of this counter is 0–9999 and it will increment when the count input transitions from off to on. The counter is reset to 0 when you turn on the reset input. The counter bit associated with the counter will turn on when the current value is equal to or greater than the preset value.

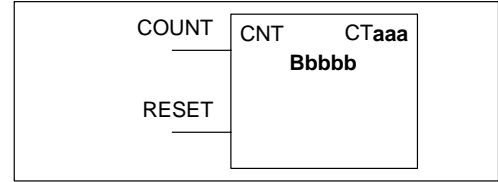

Operand Data Type	D3-330 Range		D3-340 Range		D3-330P Range		
	B	aaa	bbbb	aaa	bbbb	aaa	bbbb
Counters	CT	600-677	—	600-677	—	—	—
Data registers	R	—	400-577	—	400-577 700-777	—	—
Constant	K	—	0-9999	—	0-9999	—	—

* See Chapter 12 for similar RLL *PLUS* instructions

In the following Counter example, counter 604 will increment by one count when input 000 transitions from off to on. When input contact 001 is turned on the counter will reset to zero. The counter bit associated with counter 604 will turn on when the current value in counter 604 is \geq the preset constant value K3 (3).

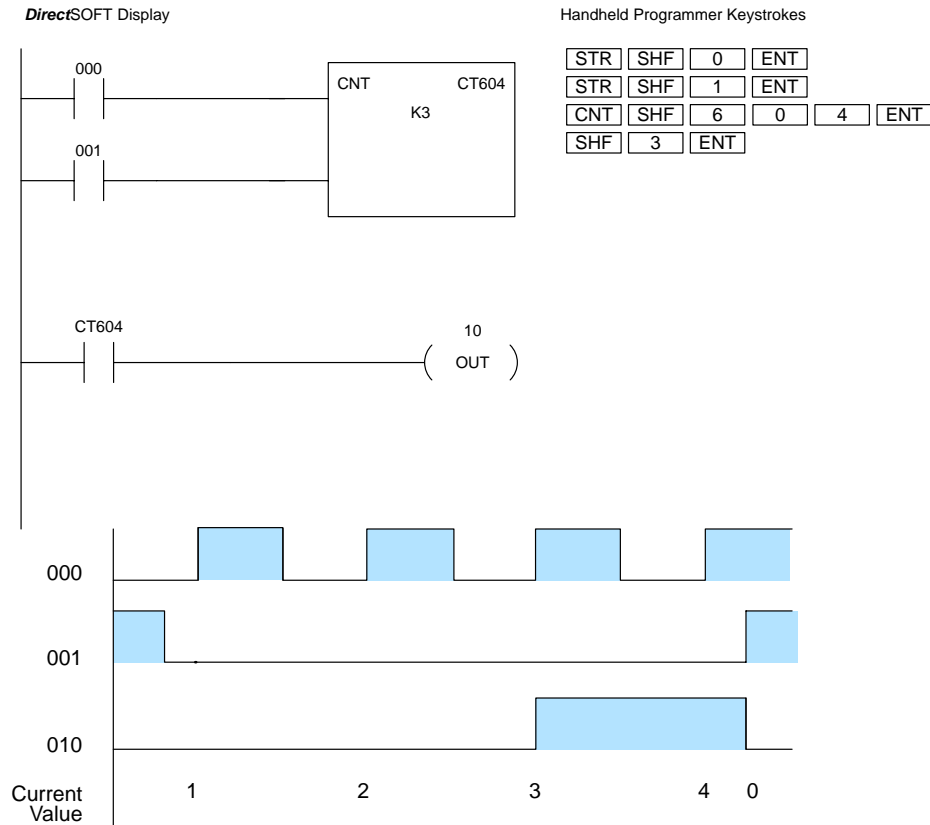

Accumulator Load and Output Instructions

Data Store DSTR (F50)

The Data Store (F50) is a 16-bit instruction that loads the value of a 16-bit register, two consecutive 8-bit registers (specify starting location), or a 4-digit BCD value into the accumulator.

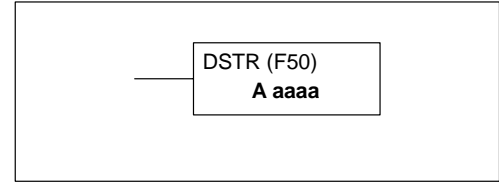

Data Out DOUT (F60)

The Data Out (F60) is a 16-bit instruction that copies the 16-bit value in the accumulator to a 16-bit reference or two consecutive 8-bit registers (specify starting location).

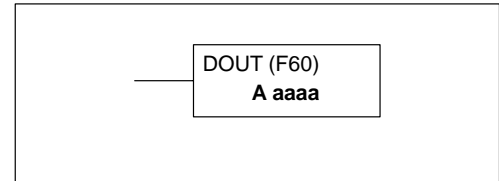

Data Type		D3-330 Range	D3-340 Range	D3-330P Range
	A	aaaa	aaaa	aaaa
Inputs / Outputs	R	000-014 070-075	000-014 070-075	000-014 070-075
Control Relays	R	016-036	016-036 100-105	016, 020-027
Shift Registers	R	040-056	040-056	—
Stages	R	—	—	100-116
Timer /Counters (16 bit)	R	600-677	600-677	600-677
Data Registers	R	400-577	400-577 700-777	400-577
*Constant (4-digit BCD)	K	0000-9999	0000-9999	0000-9999

* A constant is not a valid data type for the DOUT (F60) instruction.

In the following example, when input 000 is on the value (7502) in R402 and R403 is loaded into the accumulator using the Data Store (F50) instruction. The value in the accumulator is output to data registers R404 and R405 using the Data Out (F60) instruction.

DirectSOFT Display

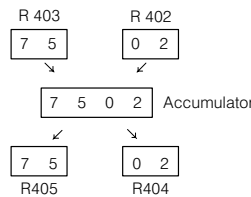
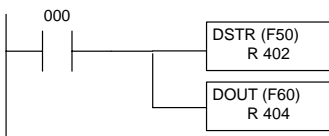

Handheld Programmer Keystrokes

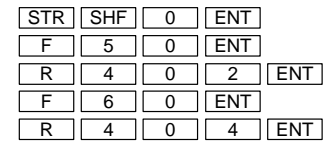

In the following example, when input 001 is on the BCD constant value K7502 is loaded into the accumulator using the Data Store (F50) instruction. The value in the accumulator is output to data registers R404 and R405 using the Data Out (F60) instruction.

DirectSOFT Display

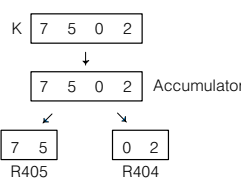
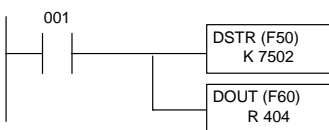

Handheld Programmer Keystrokes

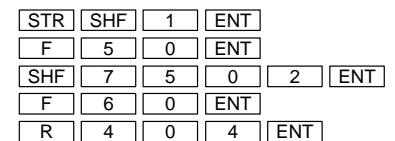

Data Store 1 DSTR (F51)

The Data Store 1 (F51) is an 8-bit instruction that loads the value from a specified 8-bit register into the lower 8 bits of the accumulator. The upper 8 bits of the accumulator are set to zero.

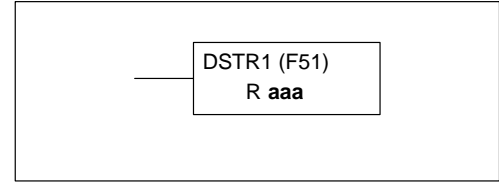

Data Out 1 DOUT (F61)

The Data Out 1 (F61) is an 8-bit instruction that copies the value in the lower 8 bits of the accumulator to a specified 8-bit register.

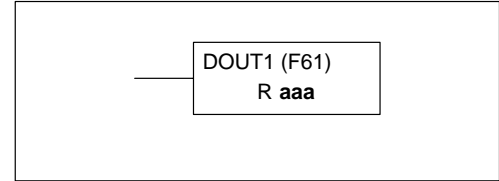

Data Type		D3-330 Range	D3-340 Range	D3-330P Range
		aaaa	aaaa	aaaa
Inputs / Outputs	R	000-014 070-075	000-014 070-075	000-014 070-075
Control Relays	R	016-036	016-036 100-105	016, 020-027
Shift Registers	R	040-056	040-056	—
Stages	R	—	—	100-116
Data Registers	R	400-577	400-577 700-777	400-577

In the following example, when input 000 is on the value (89) in R410 is loaded into the lower 8 bits of the accumulator using the Data Store 1 (F51) instruction. The value in the least significant 8 bits of the accumulator is output to data register R500 using the Data Out 1 (F61) instruction.

DirectSOFT Display

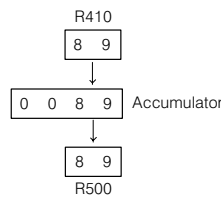
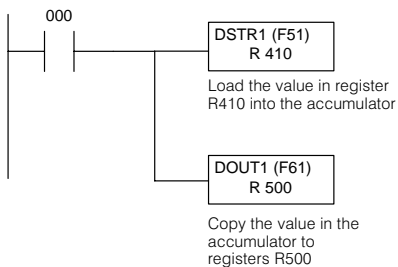

Handheld Programmer Keystrokes

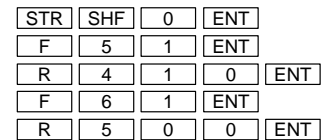

**Data Store 2
DSTR (F52)**

The Data Store 2 (F52) is a 4-bit instruction that loads the value of the most significant 4 bits of a specified 8-bit register into the least significant 4 bits of the accumulator. The remaining 12 bits of the accumulator are set to zero.

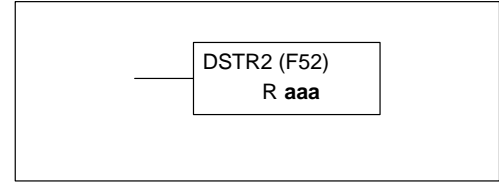

**Data Out 2
DOUT (F62)**

The Data Out 2 (F62) is a 4-bit instruction that copies the value in the least significant 4 bits of the accumulator into the most significant 4 bits of a specified 8-bit register. The lower 4 bits of the register are not altered.

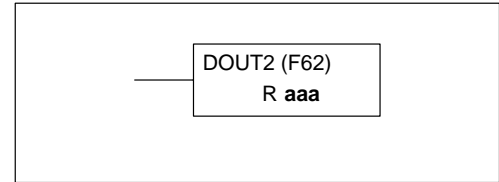

Data Type		D3-330 Range	D3-340 Range	D3-330P Range
		aaaa	aaaa	aaaa
Inputs / Outputs	R	000-014 070-075	000-014 070-075	000-014 070-075
Control Relays	R	016-036	016-036 100-105	016, 020-27
Shift Registers	R	040-056	040-56	—
Stages	R	—	—	100-116
Data Registers	R	400-577	400-577 700-777	400-577

In the following example, when input 000 is on the most significant 4 bits of R1 are loaded into the lower 4 bits of the accumulator using the Data Store 2 (F52) instruction. The value in the least significant 4 bits of the accumulator is output to most significant 4 bits of data register R400 using the Data Out 2 (F62) instruction.

DirectSOFT Display

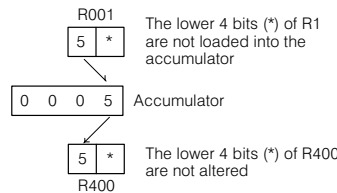
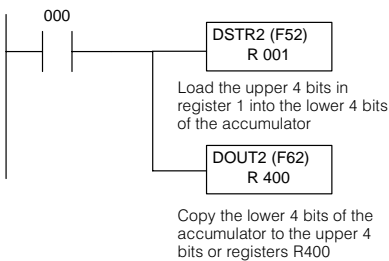

Handheld Programmer Keystrokes

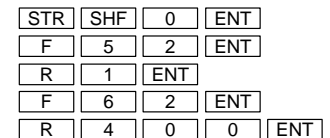

Data Store 3 DSTR (F53)

The Data Store 3 (F53) is a 4-bit instruction that loads the value of the least significant 4 bits of a specified 8-bit register into the least significant 4 bits of the accumulator. The upper 12 bits of the accumulator are set to zero.

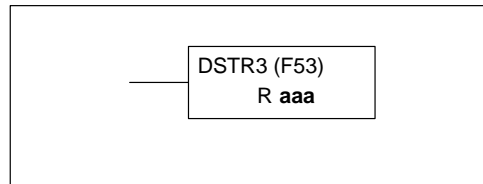

Data Out 3 DOUT (F63)

The Data Out 3 (F63) is a 4-bit instruction that copies the value in the least significant 4 bits of the accumulator to the least significant 4 bits of a specified 8-bit register. The upper 4 bits of the register are not altered.

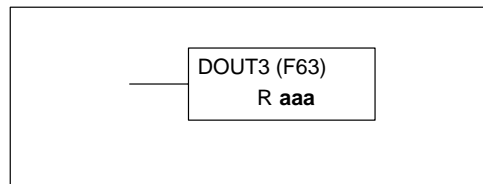

Data Type		D3-330 Range	D3-340 Range	D3-330P Range
		aaaa	aaaa	aaaa
Inputs / Outputs	R	000-014 070-075	000-014 070-075	000-014 070-075
Control Relays	R	016-036	016-036 100-105	016, 020-027
Shift Registers	R	040-056	040-056	—
Stages	R	—	—	100-116
Data Registers	R	400-577	400-577 700-777	400-577

In the following example, when input 000 is on the least significant 4 bits of R005 are loaded into the accumulator using the Data Store 3 (F53) instruction. The data in the least significant 4 bits of the accumulator is output to the least significant 4 bits of R016 using the Data Out 3 (F63) instruction.

DirectSOFT Display

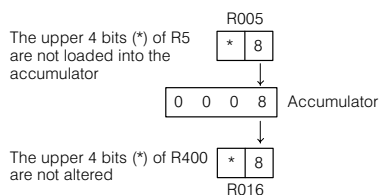
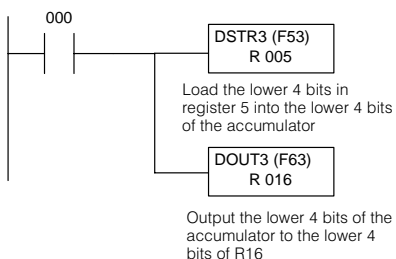

Handheld Programmer Keystrokes

STR	SHF	0	ENT
F	5	3	ENT
R	5	ENT	
F	6	3	ENT
R	1	6	ENT

**Data Store 5
DSTR (F55)**

The Data Store 5 (F55) is a 16-bit instruction that loads the value of 16 image register locations for a specified 16 point input module into the accumulator.

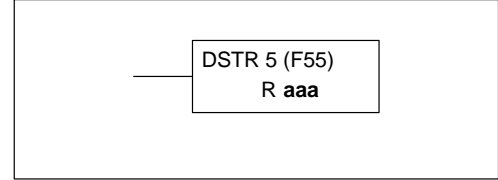

**Data Out 5
DOUT (F65)**

The Data Out 5 (F65) is a 16-bit instruction that outputs the 16 bit value in the accumulator to the image register of a specified 16 point output module.

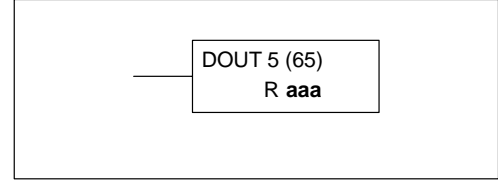

Data Type		D3-330 Range	D3-340 Range	D3-330P Range
		aaaa	aaaa	aaaa
Inputs / Outputs	R	000-014 070-075	000-014 070-075	000-014 070-075

In the following example, when input 000 is on the binary status of a 16 point I/O module in slot 1 (R000 and R010) is loaded into the accumulator using the Data Store 5 (F55) instruction. The value in the accumulator is copied to I/O register locations in slot 2 (R001 and R011) using the Data Out 5 (F65) instruction.

DirectSOFT Display

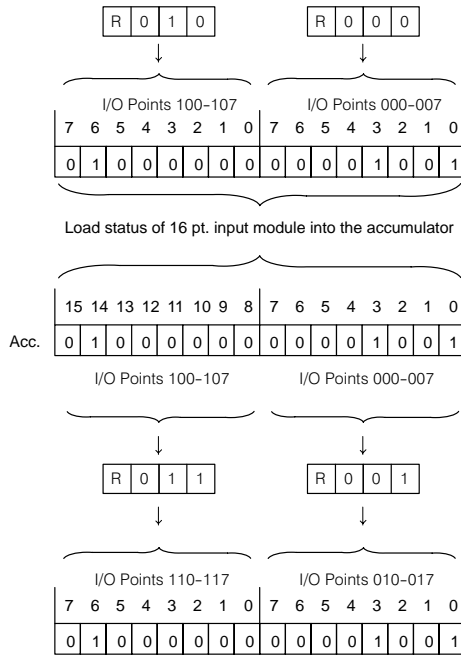
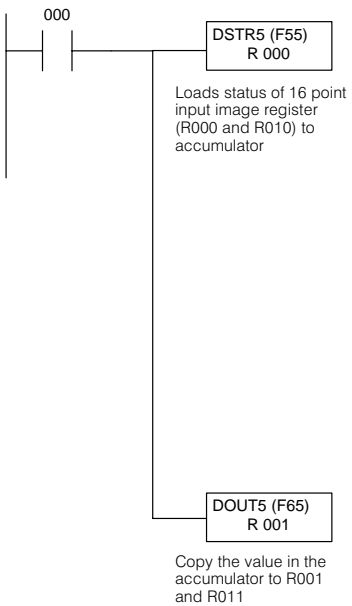

Handheld Programmer Keystrokes

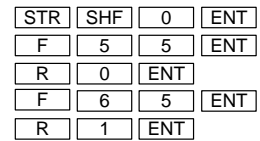

Accumulator Logic Instructions

Data And DAND (F75)

The Data And (F75) is a 16-bit instruction that logical ands the value in a 16-bit reference, two consecutive 8-bit registers (specify starting location), or a 4-digit BCD constant with the value in the accumulator. The result resides in the accumulator.

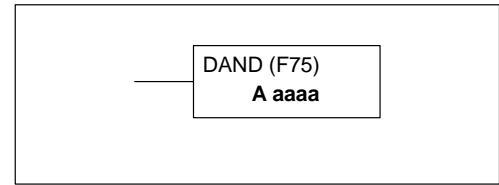

Data Type		D3-330 Range	D3-340 Range	D3-330P Range
	A	aaaa	aaaa	aaaa
Inputs / Outputs	R	000-014 070-075	000-014 070-075	000-014 070-075
Control Relays	R	016-036	016-036 100-105	016, 020-027
Shift Registers	R	040-056	040-056	—
Stages	R	—	—	100-116
Timer /Counters (16 bit)	R	600-677	600-677	600-677
Data Registers	R	400-577	400-577 700-777	400-577
Constant (4-digit BCD)	K	0000-9999	0000-9999	0000-9999

In the following example, when input 000 is on the value(6489) in R402 and R403 is loaded into the accumulator using the Data Store (F50) instruction. The data in the accumulator is logically anded with the constant K4107 with the result residing in the accumulator. The value in the accumulator is output to data register R404 and R405 using the Data Out (F60) instruction.

DirectSOFT Display

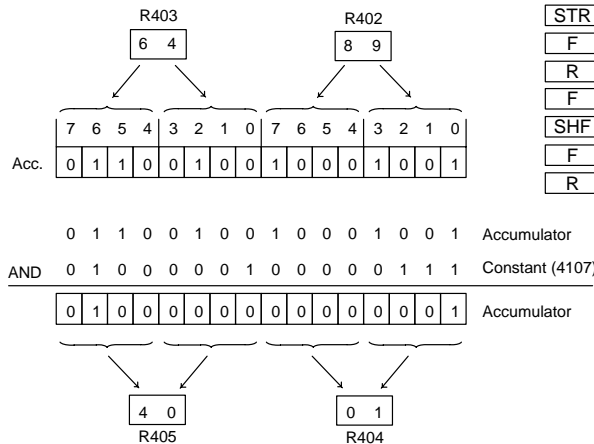
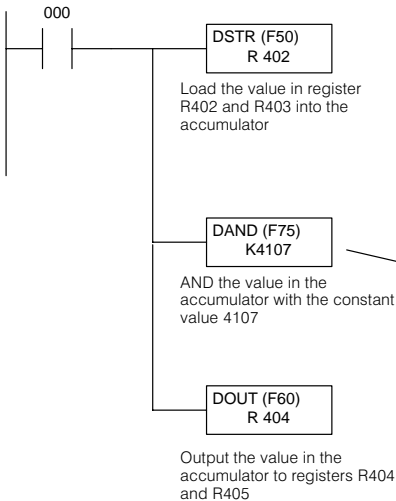

Handheld Programmer Keystrokes

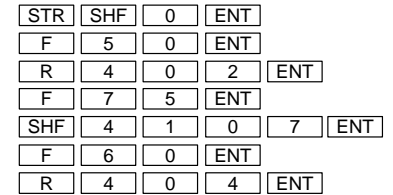

**Data Or
DOR (F76)**

The Data Or (F76) is a 16-bit instruction that logically ors the value in a 16-bit reference, two consecutive 8-bit registers, (specify starting location) or a 4-digit BCD constant with the value in the accumulator. The result resides in the accumulator.

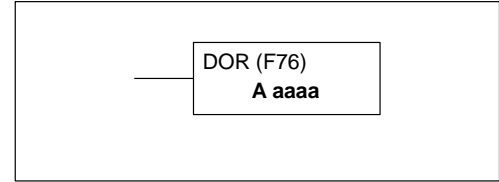

Data Type		D3-330 Range	D3-340 Range	D3-330P Range
	A	aaaa	aaaa	aaaa
Inputs / Outputs	R	000-014 070-075	000-014 070-075	000-014 070-075
Control Relays	R	016-036	016-036 100-105	016, 020-027
Shift Registers	R	040-056	040-056	—
Stages	R	—	—	100-116
Timer /Counters (16 bit)	R	600-677	600-677	600-677
Data Registers	R	400-577	400-577 700-777	400-577
Constant (4-digit BCD)	K	0000-9999	0000-9999	0000-9999

In the following example, when input 000 is on the value (6481) in R402 and R403 is loaded into the accumulator using the Data Store (F50) instruction. The data in the accumulator is logically ored with the constant K4102 with the result residing in the accumulator. The value in the accumulator is output to data registers R404 and R405 using the Data Out (F60) instruction.

DirectSOFT Display

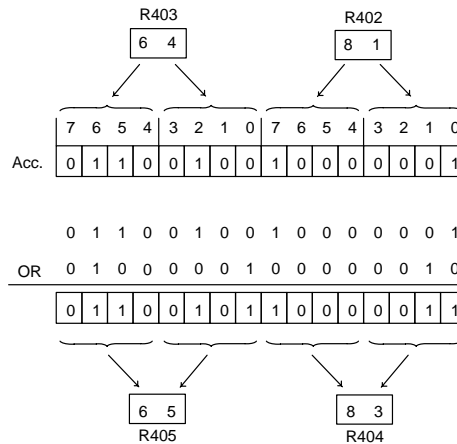
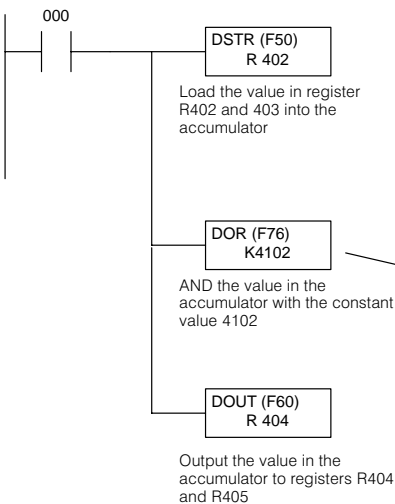

Handheld Programmer Keystrokes

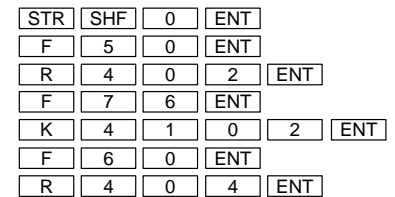

**Compare
CMP (F70)**

The Compare (F70) is a 16-bit instruction that compares the value in a 16-bit reference, two consecutive 8-bit registers (specify starting location), or a 4-digit BCD against the value in the accumulator. Discrete bit flags are used to indicate if the result of the comparison was greater than, equal to, or less than the value in the accumulator.

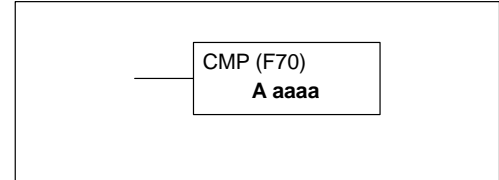

Data Type		D3-330 Range	D3-340 Range	D3-330P Range
	A	aaaa	aaaa	aaaa
Inputs / Outputs	R	000-014 070-075	000-014 070-075	000-014 070-075
Control Relays	R	016-036	016-036 100-105	016, 020-27
Shift Registers	R	040-056	040-56	—
Stages	R	—	—	100-116
Timer /Counters (16 bit)	R	600-677	600-677	600-677
Data Registers	R	400-577	400-577 700-777	400-577
Constant (4-digit BCD)	K	0000-9999	0000-9999	0000-9999

Discrete Bit Flags	Description
772	Will be on if the accumulator value is greater than the compare value
773	Will be on if the accumulator value is equal to the compare value
774	Will be on if the accumulator value is less than the compare value

In the following example, when input 000 is on the value (2132) in R402 and R403 is loaded into the accumulator using the Data Store (F50) instruction. The data in the accumulator is compared to value in data registers R404 and R405 using the Compare (F70) instruction. Discrete status flag 774 is used to indicate if the accumulator is less than the compare value in this example.

DirectSOFT Display

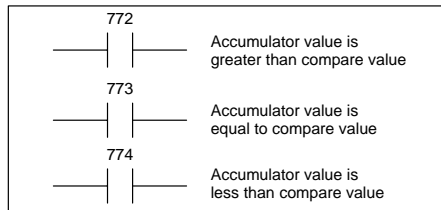
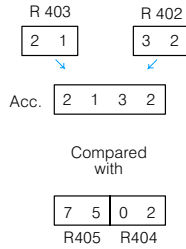
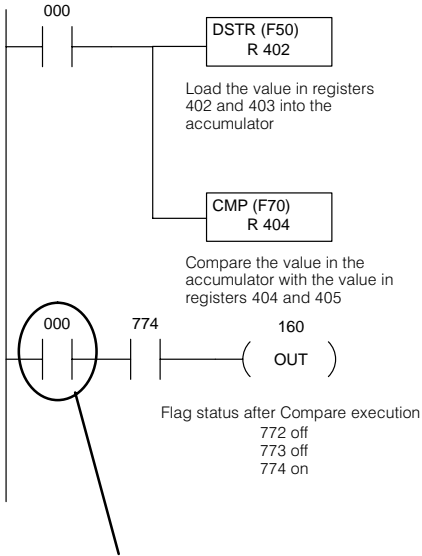

Handheld Programmer Keystrokes

STR	SHF	0	ENT
F	5	0	ENT
R	4	0	2 ENT
F	7	0	ENT
R	4	0	4 ENT
STR	SHF	0	ENT
AND	SHF	7	7 4 ENT
OUT	SHF	1	6 0 ENT

NOTE: Input 000 has been used to interlock output 160. This is done since an earlier comparison could result in status flag 774 coming on when this particular comparison is not being executed thereby providing the opportunity for an unexpected output signal on output 160.

It is a common mistake to just use the status flags without interlocking to control outputs in a program but, status flags 772 – 774 can change several times during the same scan. Just as you should not use the status flags by themselves to control outputs, you also should not monitor status flags within the program. Instead you should monitor the interlocked outputs controlled by the status flags.

Math Instructions

Add ADD (F71)

The Add (F71) is a 16-bit instruction that adds the value of a 16 bit reference, two consecutive 8-bit registers (specify starting location), or a 4-digit BCD value with the value in the accumulator. The result resides in the accumulator. Discrete bit flags are used to indicate if the result had a carry digit or if the result was zero.

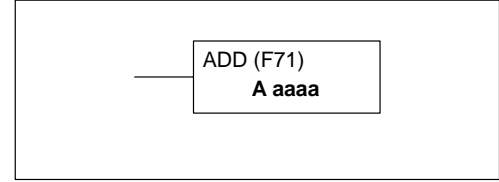

Data Type		D3-330 Range	D3-340 Range	D3-330P Range
	A	aaaa	aaaa	aaaa
Inputs / Outputs	R	000-014 070-075	000-014 070-075	000-014 070-075
Control Relays	R	016-036	016-036 100-105	016, 020-027
Shift Registers	R	040-056	040-056	—
Stages	R	—	—	100-116
Timer /Counters (16 bit)	R	600-677	600-677	600-677
Data Registers	R	400-577	400-577 700-777	400-577
Constant (4-digit BCD)	K	0000-9999	0000-9999	0000-9999

Discrete Bit Flags	Description
775	Will be on if the operation results in a carry
776	Will be on if the result is 0

In the following example, when input 000 is on the value (3619) in R402 and R403 is loaded into the accumulator using the Data Store (F50) instruction. The Add instruction (F71) adds the value (2602) in R410 and R411 to the value in the accumulator. The result in the accumulator is then copied to data registers R404 and R405 with the Data Out (F60) instruction.

DirectSOFT Display

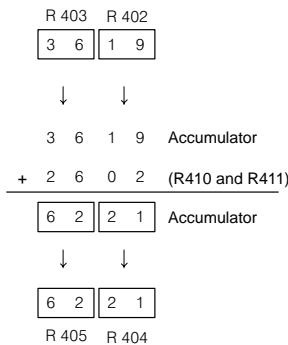
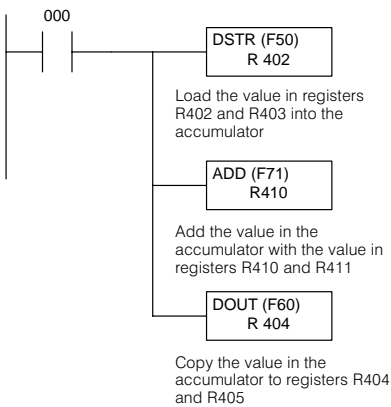

Handheld Programmer Keystrokes

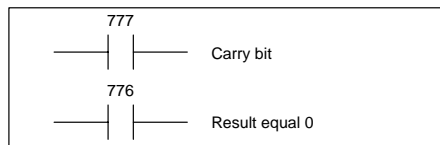
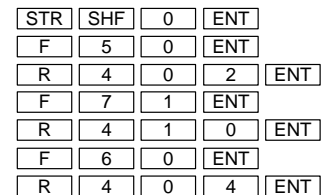

Add Example

The following examples demonstrate how the discrete status flags are used to indicate if the result of the add has produced a number which exceeds the capacity of the accumulator. Remember, the accumulator has a 4 digit maximum. When a calculation produces a number larger than 4 digits, part of this number is lost. The following table shows different values being used in the logic example below. Notice how the discrete status flags change.

	Registers for DSTR Instruction R401/R400	Registers for ADD Instruction R403/R402	Registers for DOUT Instruction R405/R404	Discrete Status Flag 775	Discrete Status Flag 776
Example 1	500	400	0900	off	off
Example 2	5000	5000	0000	on	on
Example 3	5050	5000	0050	on	off

DirectSOFT Display

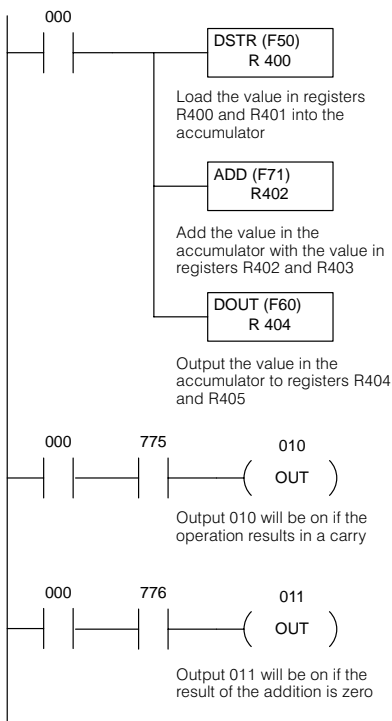

Handheld Programmer Keystrokes

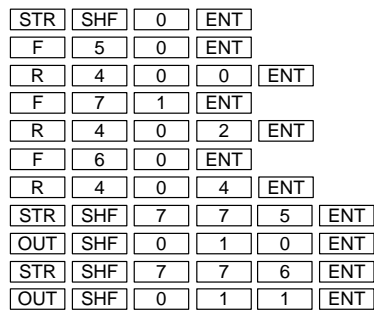

NOTE: An input has been used to interlock the outputs on the last two rungs. This is done since an earlier math instruction could result in the status flag coming on when this particular math instruction is not being executed thereby providing the opportunity for an unexpected output signal.

It is a common mistake to just use the status flags without interlocking to control outputs in a program but, the status flags can change several times during the same scan. Just as you should not use the status flags by themselves to control outputs, you also should not monitor status flags within the program. Instead you should monitor the interlocked outputs controlled by the status flags.

Subtract SUB (F72)

The Subtract (F72) is a 16-bit instruction that subtracts the value in a 16-bit register, two consecutive 8-bit registers (specify starting location), or a 4-digit BCD value from the value in the accumulator. The result resides in the accumulator. Discrete bit flags are used to indicate if the result had a borrow digit or the result was zero.

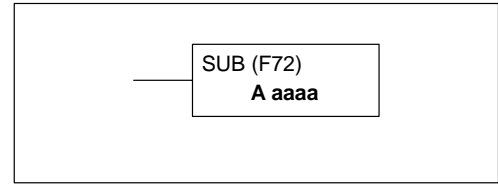

Data Type		D3-330 Range	D3-340 Range	D3-330P Range
	A	aaaa	aaaa	aaaa
Inputs / Outputs	R	000-014 070-075	000-014 070-075	000-014 070-075
Control Relays	R	016-036	016-036 100-105	016, 020-027
Shift Registers	R	040-056	040-056	—
Stages	R	—	—	100-116
Timer /Counters (16 bit)	R	600-677	600-677	600-677
Data Registers	R	400-577	400-577 700-777	400-577
Constant (4-digit BCD)	K	0000-9999	0000-9999	0000-9999

Discrete Bit Flags	Description
775	Will be on if the result if a borrow digit occurred
776	Will be on if the result is 0

In the following example, when input 000 is on the value (3619) in R402 and R403 is loaded into the accumulator using the Data Store (F50) instruction. The constant value K1406 is subtracted from the value in the accumulator using the Subtract (F72) instruction. The result in the accumulator is then copied to data registers R404 and R405 using the Data Out (F60) instruction.

DirectSOFT Display

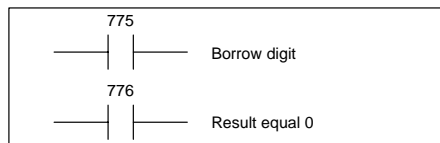
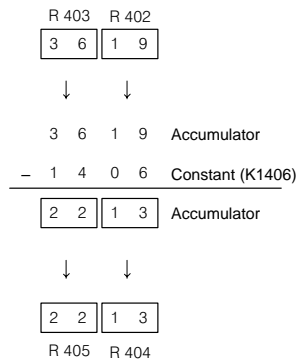
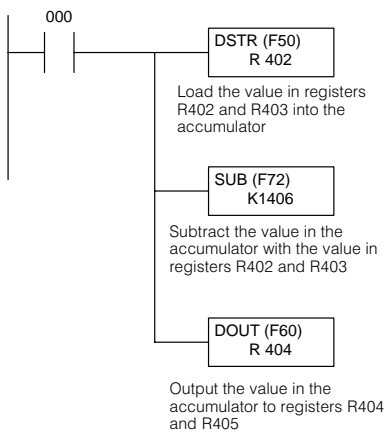

Handheld Programmer Keystrokes

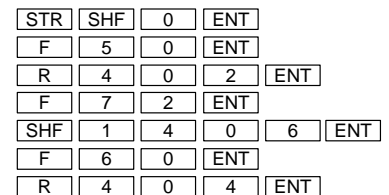

Subtract Example

The following examples demonstrate how the discrete status flags are used to indicate if the result of the Subtraction is a 0 or required a borrow digit. The following table shows different values being used in the logic example below. Notice how the discrete status flags change for each example.

	Registers for DSTR Instruction R401/R400	Registers for SUB Instruction R403/R402	Registers for DOUT Instruction R405/R404	Discrete Status Flag 775	Discrete Status Flag 776
Example 1	6050	5000	1050	off	off
Example 2	7050	7050	0000	off	on
Example 3	5000	6000	9000*	on	off

* The DL305 cannot process negative numbers. When the number being subtracted from the accumulator is larger than the number in the accumulator, a borrow digit occurs and the subtraction is completed. The value in the accumulator does not represent the difference between the two numbers. To get the difference between the two numbers in Example 3 the result (9000) in the accumulator is subtracted from 0. The final result is 1000, the difference between 6000 and 5000.

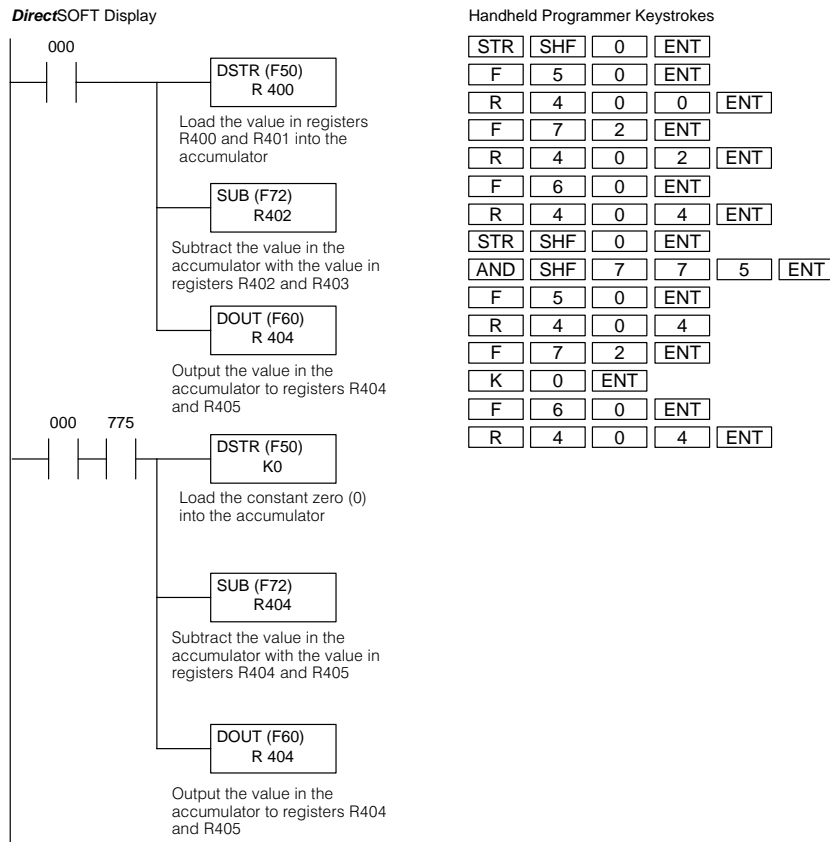

NOTE: It is a common mistake to just use the status flags without interlocking to control outputs in a program, but the status flags can change several times during the same scan. Just as you should not use the status flags by themselves to control outputs, you also should not monitor status flags within the program. Instead you should monitor the interlocked outputs controlled by the status flags.

Multiply MUL (F73)

The Multiply (F73) is a 16-bit instruction that multiplies the value in a 16-bit register, two consecutive 8-bit registers, or a 4-digit BCD value by the value in the accumulator. The least significant four digits of the result are stored in the accumulator and the most significant four digits are stored in the auxiliary accumulator (R575 and R577). A discrete bit flag is used to indicate if the result was zero.

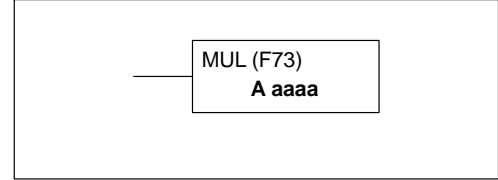

Data Type		D3-330 Range	D3-340 Range	D3-330P Range
	A	aaaa	aaaa	aaaa
Inputs / Outputs	R	000-014 070-075	000-014 070-075	000-014 070-075
Control Relays	R	016-036	016-036 100-105	016, 020-027
Shift Registers	R	040-056	040-056	—
Stages	R	—	—	100-116
Timer /Counters (16 bit)	R	600-677	600-677	600-677
Data Registers	R	400-577	400-577 700-777	400-577
Constant (4-digit BCD)	K	0000-9999	0000-9999	0000-9999

Discrete Bit Flags	Description
776	Will be on if the result is 0

In the following example, when input 000 is on the value (3619) in R402 and R403 is loaded into the accumulator using the Data Store (F50) instruction. The data in the accumulator is multiplied with the constant K2 with the result residing in the accumulator and auxiliary accumulator (R576 and R577) using the Multiply (F73) instruction. The value in the accumulator is output to data registers R404 and R405 using the Data Out (F60) instruction.

DirectSOFT Display

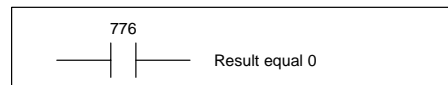
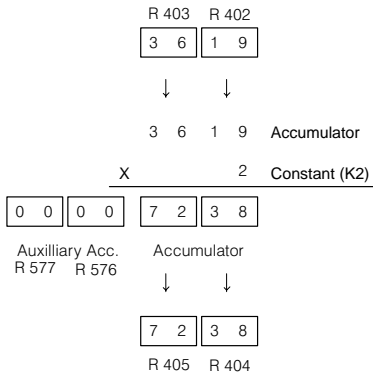
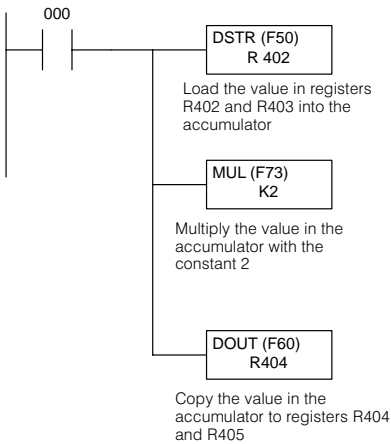

Handheld Programmer Keystrokes

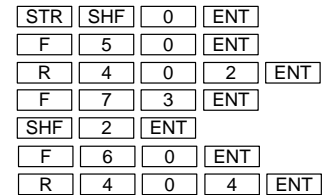

Multiply Example

The multiply instruction allows you to multiply two 4-digit numbers together. The result is located in the accumulator and the auxiliary accumulator (R576 and R577) when necessary. The accumulator holds the lower 4 digits of the result and the auxiliary accumulator holds the upper 4 digits.

Whenever possible multiplications resulting in more than 4 digits should be avoided since the DL305 instruction set can only manipulate a maximum of two consecutive 8-bit registers (4 digits) at one time.

If the result of a multiplication is greater than 4 digits, the application program must be written to compensate for the instruction set 4 digit maximum for data manipulation. The example below shows how the auxiliary accumulator is used to store a result with more than 4 digits and how to access the upper 4 digits.

The example below shows how the auxiliary accumulator is used to process numbers larger than 4 digits when the multiplication instruction is used.

DirectSOFT Display

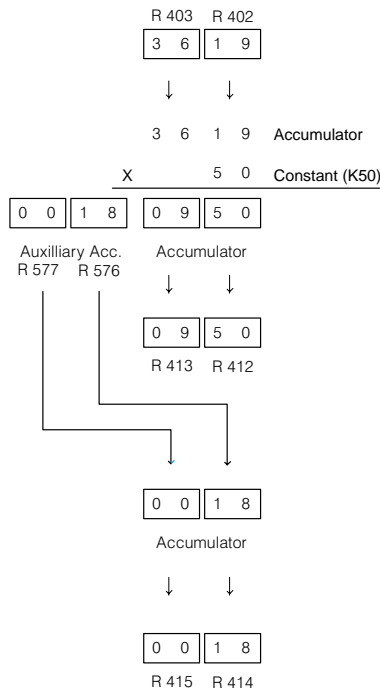
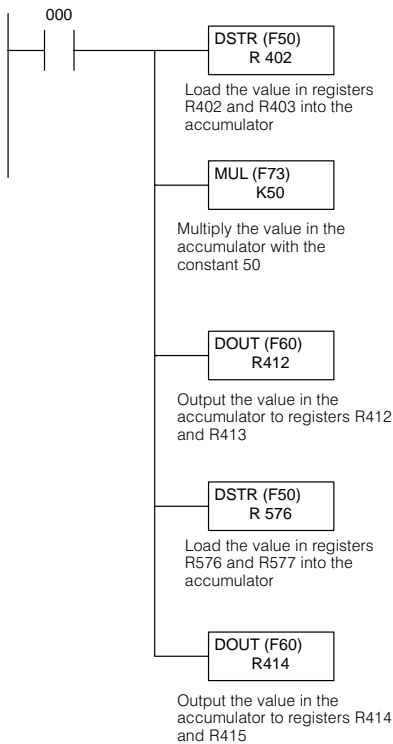

Handheld Programmer Keystrokes

STR	SHF	0	ENT
F	5	0	ENT
R	4	0	2 ENT
F	7	3	ENT
SHF	5	0	ENT
F	6	0	ENT
R	4	1	2 ENT
F	5	0	ENT
R	5	7	6 ENT
F	6	0	ENT
R	4	1	4 ENT

Divide DIV (F74)

The Divide (F74) is a 16-bit instruction that divides the value in the accumulator by the value in a 16-bit register, two consecutive 8-bit registers, or a 4-digit BCD value. The integer portion of the result is stored in the accumulator and the decimal fraction is stored in the auxiliary accumulator, R576 and R577. Discrete flags are used to indicate if the dividend or divisor is zero or if only the divisor is zero.

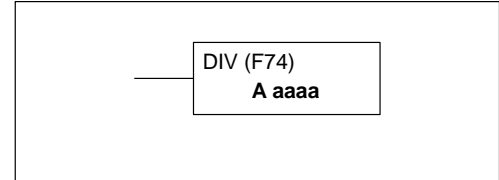

Data Type		D3-330 Range	D3-340 Range	D3-330P Range
	A	aaaa	aaaa	aaaa
Inputs / Outputs	R	000-014 070-075	000-014 070-075	000-014 070-075
Control Relays	R	016-036	016-036 100-105	016, 020-027
Shift Registers	R	040-056	040-056	—
Stages	R	—	—	100-116
Timer /Counters (16 bit)	R	600-677	600-677	600-677
Data Registers	R	400-577	400-577 700-777	400-577
Constant (4-digit BCD)	K	0000-9999	0000-9999	0000-9999

Discrete Bit Flags	Description
776	Will be on if the dividend or divisor is zero
777	Will be on if the divisor is zero

In the following example, when input 000 is on the value (530) in R402 and R403 is loaded into the accumulator using the Data Store (F50) instruction. The data in the accumulator is divided by the constant 10 (K10). The result in the accumulator and is copied to data registers R404 and R405 using the Data Out (F60) instruction. The remainder is in the auxiliary accumulator (R576 and R577).

DirectSOFT Display

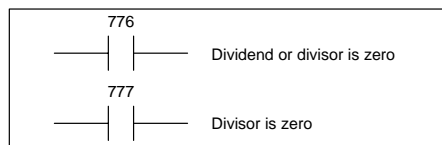
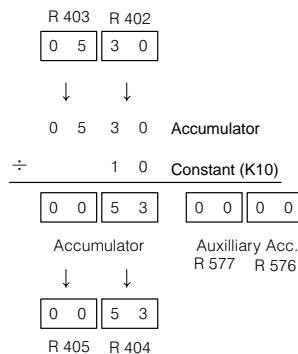
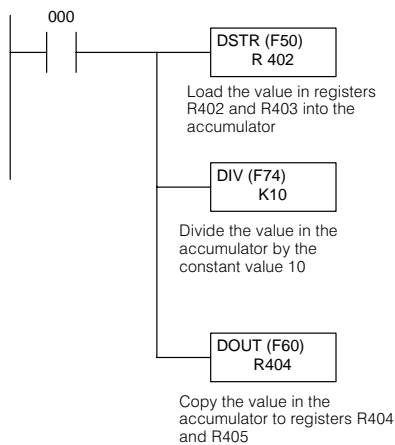

Handheld Programmer Keystrokes

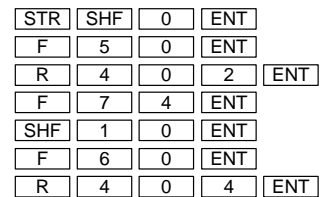

Divide Example

The divide instruction allows you to divide the value in the accumulator by 4 digits maximum. The divide instruction uses the accumulator for the integer value of the result and the auxiliary accumulator (R576 and R577) for fraction. The instruction set only allows manipulation on two consecutive registers at a time. For example, if the result was a 4 digit number with a remainder it would have to be treated like two 4-digit numbers in the program. Manipulating numbers over 4 digits should be avoided whenever possible. If it cannot be avoided the application program must be written to compensate for the 4-digit maximum for data manipulation.

The example below shows how the auxiliary accumulator is used to store the fractional portion of the result and how to access the remainder.

DirectSOFT Display

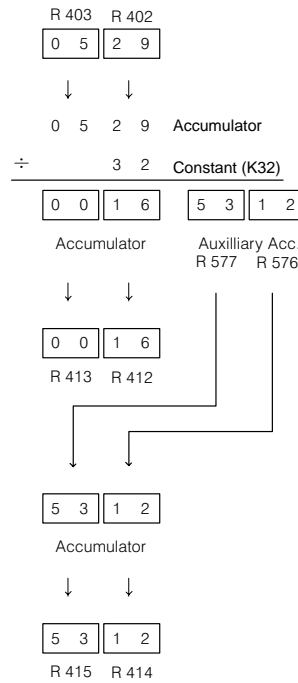
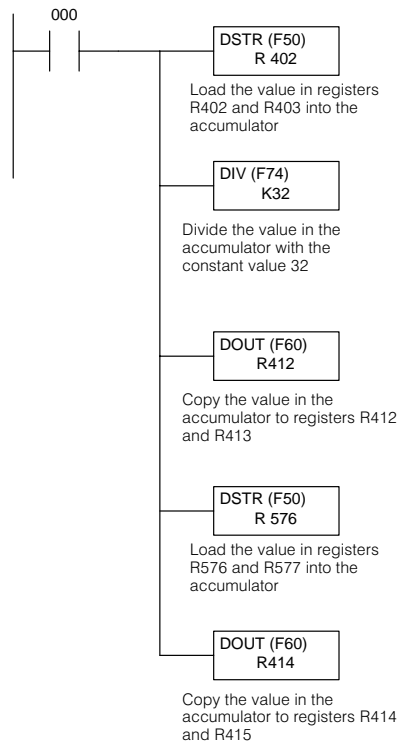

Handheld Programmer Keystrokes

STR	SHF	0	ENT
F	5	0	ENT
R	4	0	2 ENT
F	7	4	ENT
SHF	3	2	ENT
F	6	0	ENT
R	4	1	2 ENT
F	5	0	ENT
R	5	7	6 ENT
F	6	0	ENT
R	4	1	4 ENT

Bit Operation Instructions

Shift Left SHFL (F81)

The Shift Left (F81) is a 16-bit instruction that shifts the value in the accumulator a specified number of bits (15 maximum) to the left. Discrete bit flags are used to indicate if a "1" was shifted out of the accumulator or if the accumulator equals "0" after the shift.

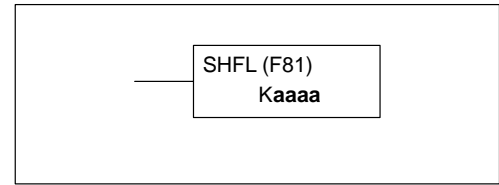

Data Type	D3-330 Range	D3-340 Range	D3-330P Range
	aaaa	aaaa	aaaa
Constant (4-digit BCD)	K	1-16	1-16

Discrete Bit Flags	Description
775	Will be on if a "1" was shifted out of the accumulator.
776	Will be on if the accumulator equals zero after the shift instruction is executed.

In the following example, when input 000 is on the value in R000 and R010 is loaded into the accumulator using the Data Store 5 (F55) instruction. The bit pattern in the accumulator is shifted to the left 4 bit positions using the Shift Left (F81) instruction with the result resides in the accumulator. The value in the accumulator is copied to data registers R404 and R405 using the Data Out (F60) instruction.

DirectSOFT Display

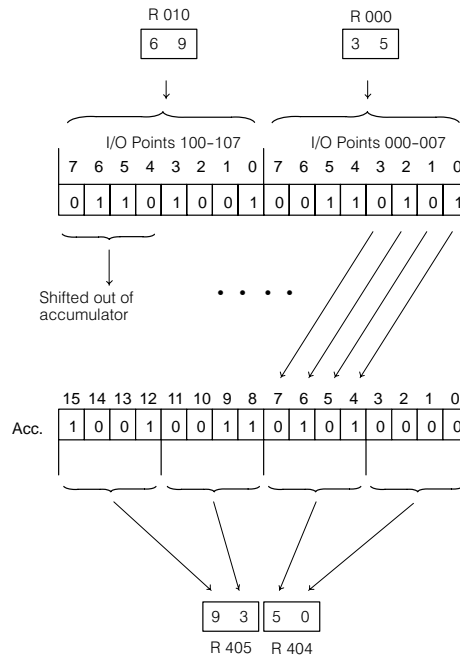
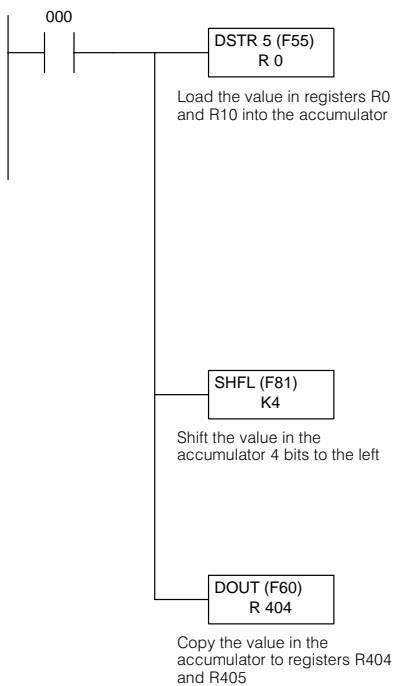

Handheld Programmer Keystrokes

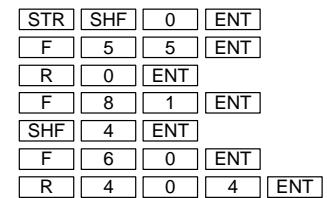

775 will be ON after the shift
776 will be OFF after the shift

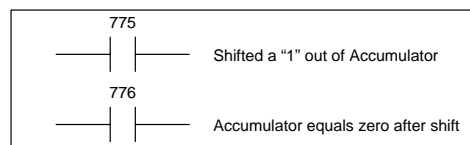

**Shift Right
SHFR (F80)**

The Shift Right (F80) is a 16-bit instruction that shifts the value in the accumulator a specified number of bits (15 maximum) to the right. Discrete bit flags are used to indicate if a "1" was shifted out of the accumulator or if the accumulator equals "0" after the shift.

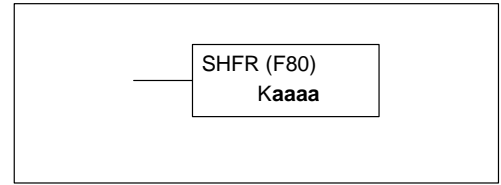

Data Type	D3-330 Range	D3-340 Range	D3-330P Range
	aaaa	aaaa	aaaa
Constant (4-digit BCD) K	1-16	1-16	1-16

Discrete Bit Flags	Description
775	Will be on if a "1" was shifted out of the accumulator.
776	Will be on if the accumulator equals zero after the shift instruction is executed.

In the following example, when input 000 is on the value in R000 and R010 is loaded into the accumulator using the Data Store (F55) instruction. The bit pattern in the accumulator is shifted 4 bit positions using the Shift Right (F80) instruction and the result resides in the accumulator. The value in the accumulator is copied to data registers R404 and R405 using the Data Out (F60) instruction.

DirectSOFT Display

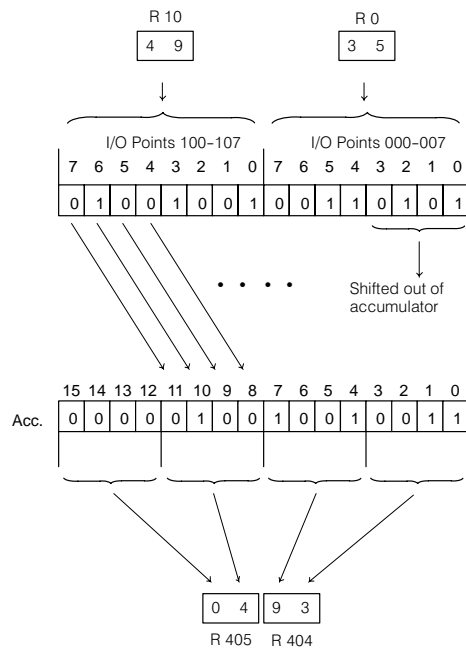
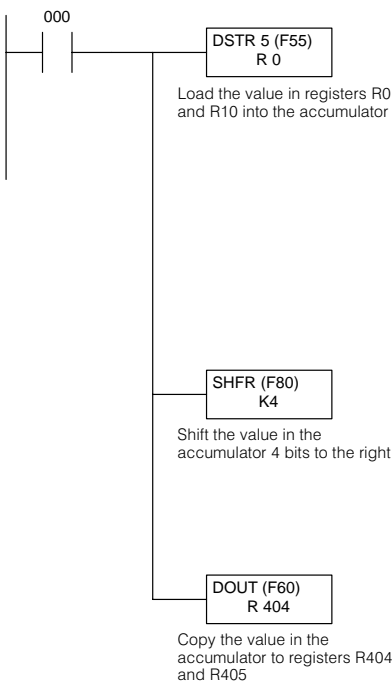

Handheld Programmer Keystrokes

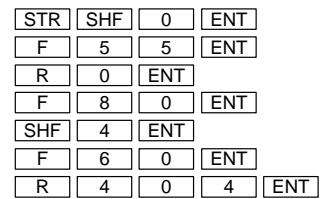

775 will be ON after the shift
776 will be OFF after the shift

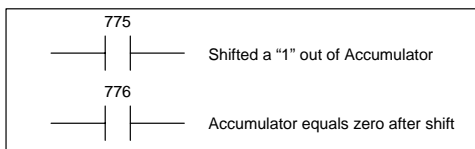

Number Conversion Instructions

Encode ENCOD (F83)

The Encode instruction encodes the accumulator bit position that contains a 1 by returning the corresponding binary representation. If the most significant bit is set to HEX F (decimal 15), the binary value 15 is returned to the accumulator. If the accumulator value is 0000 or 0001 a zero will be returned to the accumulator. If there is more than one bit position set to a "1" the least significant "1" will be encoded. The discrete bit flag 777 is used to indicate if there were multiple 1s in the accumulator.

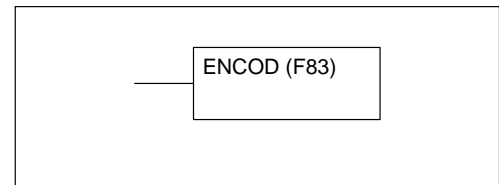

Discrete Bit Flags	Description
777	Will be on if there was more than one bit position set to a "1" in the accumulator.

In the following example, when input 000 is on the 16-bit binary pattern from registers R005 and R015 is loaded in the accumulator by the Data Store 5 (F55) instruction. In this example the 6th bit (BCD 40) is on. When the Encode (F83) instruction executes the accumulator will contain the BCD value of 6. The lower four bits of the accumulator are copied to the lower four bits of register R404 by the Data Out 3 (F63) instruction.

DirectSOFT Display

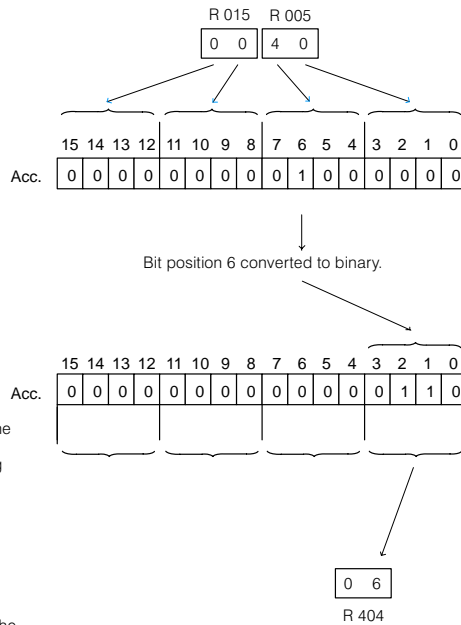
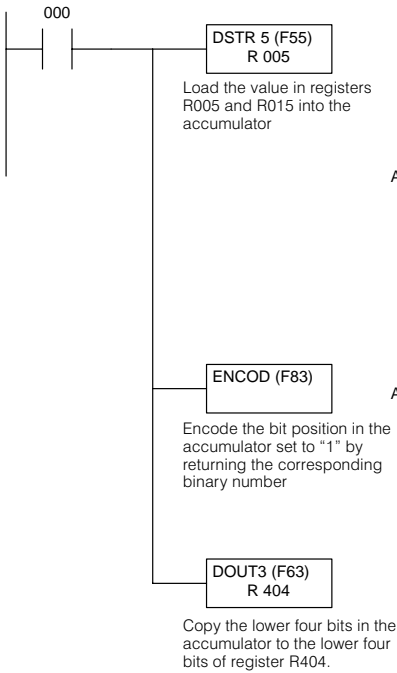

Handheld Programmer Keystrokes

STR	SHF	0	ENT
F	5	5	ENT
R	5	ENT	
F	8	3	ENT
F	6	3	ENT
R	4	0	4 ENT

Decode DECOD (F82)

The Decode instruction decodes a four bit binary number (0-F) in the accumulator and sets the corresponding bit position to a one. If the accumulator contains a HEX F (decimal 15) the most significant bit (bit 15) will be set in the accumulator. If the accumulator contains a zero the least significant bit (bit 0) will be set to a one. All other bits in the accumulator will be set to a zero.

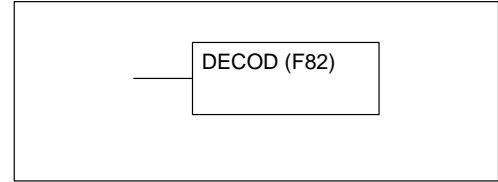

In the following example, when 000 is on the binary value of the lower four bits in R016 (5) will be loaded in the accumulator by the Data Store 3 (F53) instruction. The Decode instruction will then translate the value 5 to a 1 in the fifth bit position of the accumulator. The value 20 in the accumulator is copied to data registers R404 and R405 with the Data Out (F60) instruction.

DirectSOFT Display

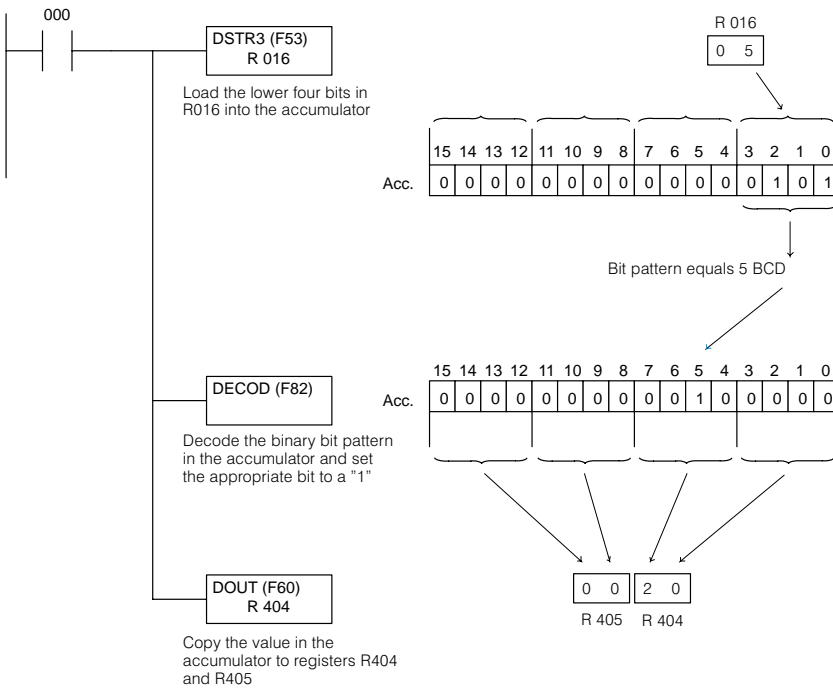

Handheld Programmer Keystrokes

STR	SHF	0	ENT	
F	5	3	ENT	
R	1	6	ENT	
F	8	2	ENT	
F	6	0	ENT	
R	4	0	4	ENT

**Binary
BIN (F85)**

The Binary (F85) instruction converts a BCD value in the accumulator to the binary/HEX equivalent value. The result of the conversion resides in the accumulator.

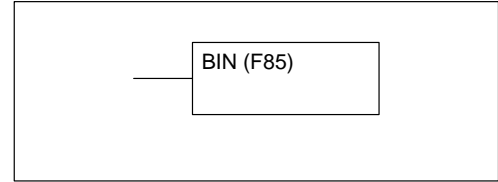

In the following example, when input 000 is on the value (2571 BCD) in R600 is loaded into the accumulator using the Data Store (F50) instruction. The value in the accumulator is converted to a binary number (HEX 0A0B) using the Binary (F85) instruction with the result residing in the accumulator. The value in the accumulator is copied to I/O registers R000 and R010 (which corresponds to I/O points 0-7 and 100-107) with the Data Out 5 (F65) instruction.

DirectSOFT Display

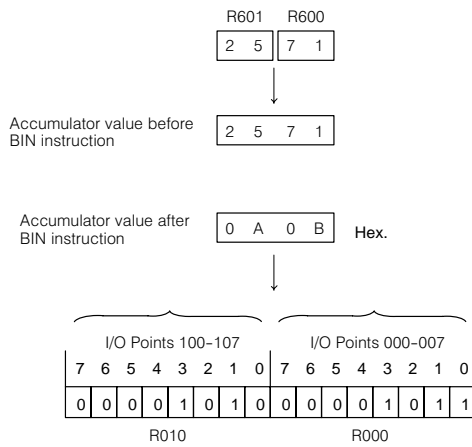
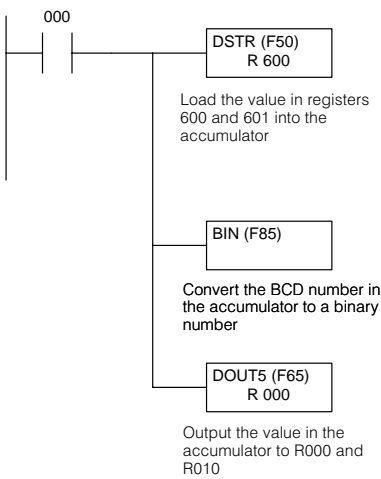

Handheld Programmer Keystrokes

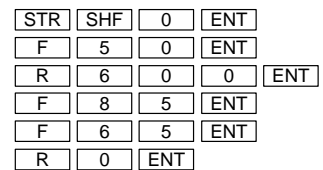

Binary Coded Decimal (BCD) (F86)

The Binary Coded Decimal (F86) instruction converts a binary/HEX value in the accumulator to the BCD equivalent. The result of the conversion resides in the accumulator.

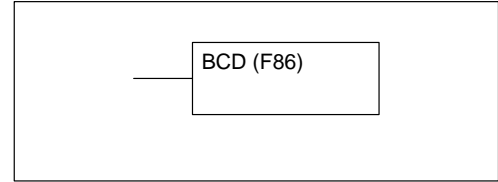

In the following example, when input 000 is on the value (HEX 0A0A) in R000 and R010 is loaded into the accumulator with the Data Store 5 (F55) instruction. The value in the accumulator is converted to a BCD number (BCD 2570) using the BCD (F86) instruction with the result residing in the accumulator. The value in the accumulator is output to register R600 using the Data Out (F60) instruction.

DirectSOFT Display

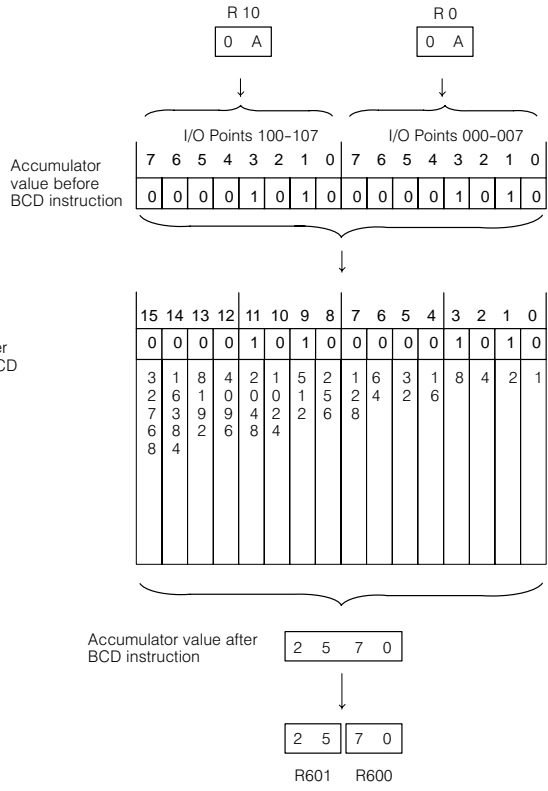
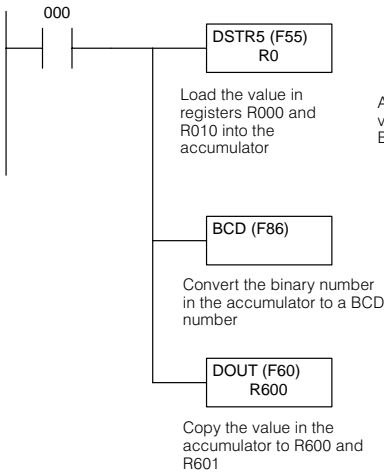

Handheld Programmer Keystrokes

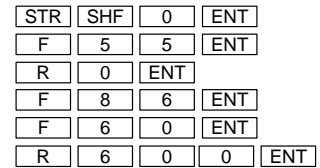

**Invert
INV (F84)**

The Invert instruction generates the one's complement of the number in the accumulator. The result is stored in the accumulator.

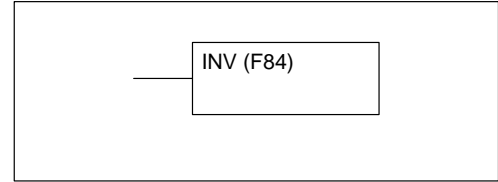

In the following example, when input 000 is on the value (AD63) in R000 and R010 is loaded into the accumulator using the Data Store (F55) instruction. The value in the accumulator is inverted with the result residing in the accumulator. The value (HEX 529C) is copied to registers R404 and R405 using the Data Out (F60) instruction.

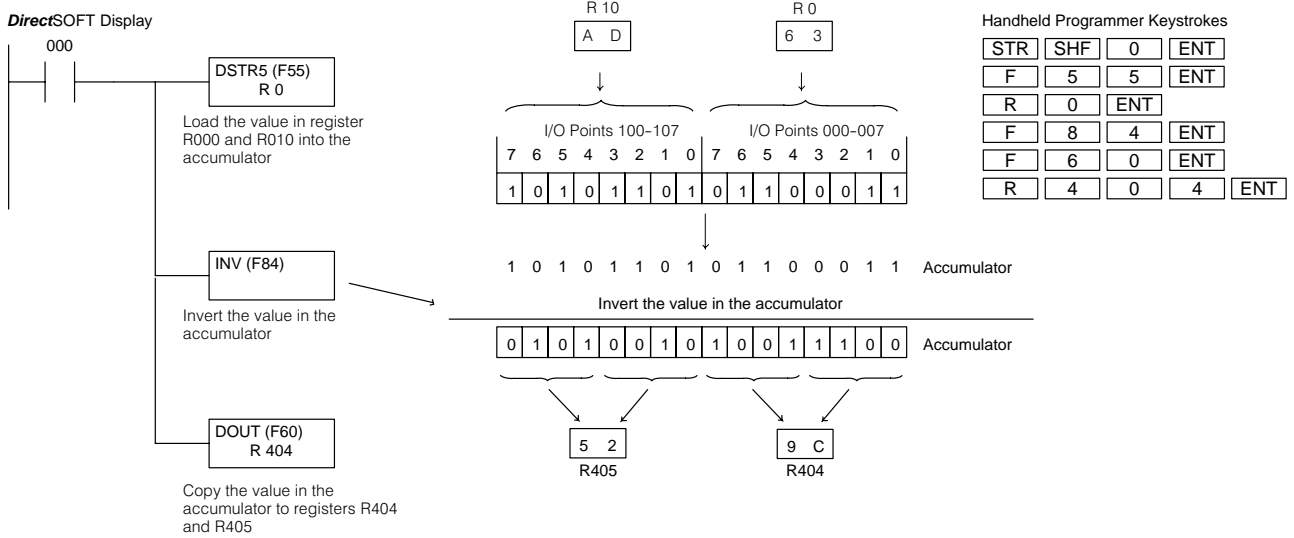

Program Control Instructions

Master Control Set (MCS) DL330/DL340 Only

The Master Control Set and Master Control Reset instructions are used to provide an additional left power rail which is controllable by an input contact. This is sometimes known as a sub power rail. Any number of rungs of ladder logic can be disabled using these instructions.

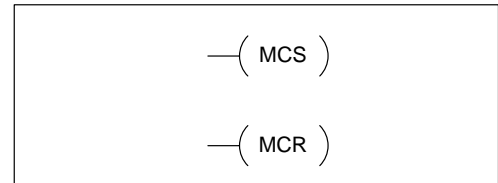

Master Control Reset (MCR) DL330/DL340 only

Understanding Master Control Relays

The Master Control Set (MCS) and Master Control Reset (MCR) instructions allow you to quickly enable (or disable) sections of the RLL program. This provides program control flexibility. The following example shows how the MCS and MCR instructions operate by creating a sub power rail for control logic.

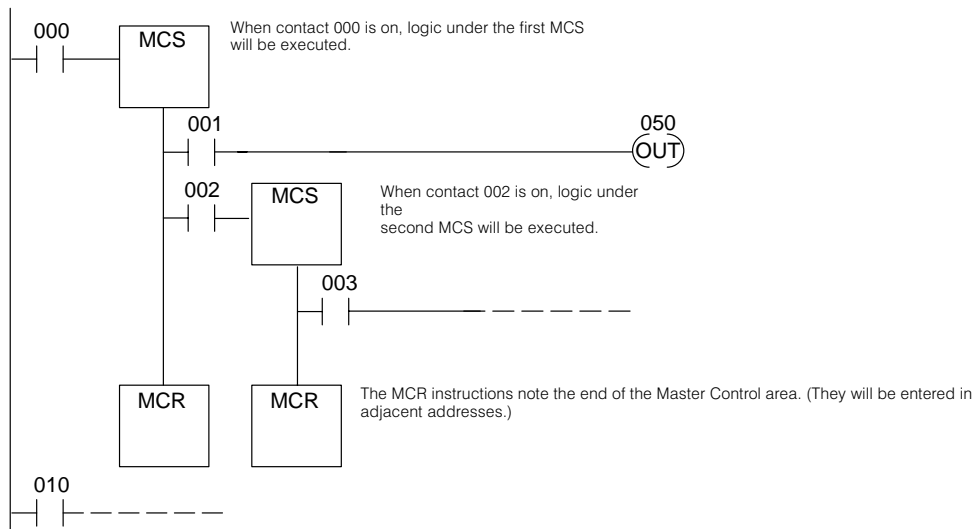

MCS/MCR Example In the following MCS/MCR example logic between the first MCS (A) and the last MCR (B) will function only if input 000 is on. The logic between the second MCS (C) and the next to last MCR (D) will function only if input 010 is on. The last rung is not controlled by either of the MCS coils.

DirectSOFT Display

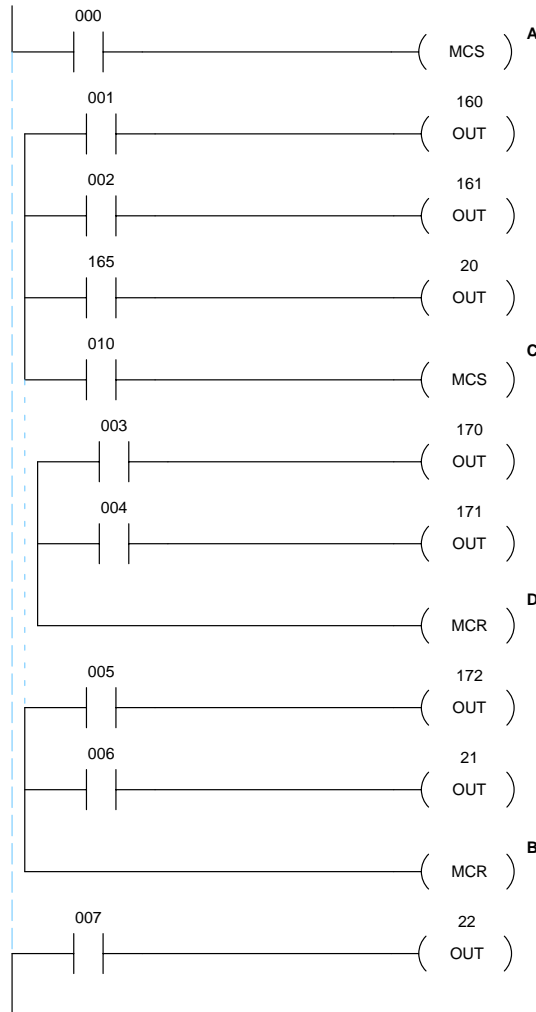

Handheld Programmer Keystrokes

```

STR SHF 0 ENT
MCS ENT
STR SHF 1 ENT
OUT SHF 1 6 0 ENT
STR SHF 2 ENT
OUT SHF 1 6 1 ENT
STR SHF 1 6 5 ENT
OUT SHF 2 0 ENT
STR SHF 1 0 ENT
MCS ENT
STR SHF 3 ENT
OUT SHF 1 7 0 ENT
STR SHF 4 ENT
OUT SHF 1 7 1 ENT
MCR ENT
STR SHF 5 ENT
OUT SHF 1 7 2 ENT
STR SHF 6 ENT
OUT SHF 2 1 ENT
MCR ENT
STR SHF 7 ENT
OUT SHF 2 2 ENT
    
```

NOTE: When programming the MCS instruction, do not put any parallel coils in the rung with the MCS.

Network Instructions

Read from Network RX (F952) DL340 Only

The Read from Network instruction is used by the master device on a *DirectNET* network to read a block of data from another CPU or *DirectNET* interface module. The function parameters are loaded into the accumulator and the first and second level of the accumulator stack by three additional instructions. Listed below are the steps necessary to program the Read from Network function.

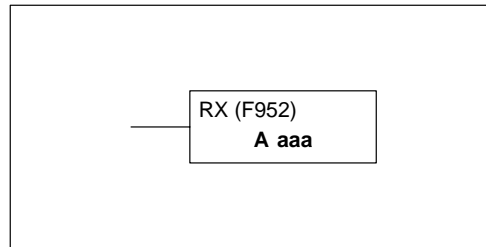

Step 1: — Load the slave address (1–90 BCD) into the accumulator with the DSTR instruction. This must always be preceded by 00, so address 20 would be 0020. (Remember, D4–DCM slave device addresses are set with switches that use a hexadecimal format. Make sure you convert this address to the decimal equivalent for use with this instruction.)

Step 2: — Load the number of bytes (1 – 128 BCD) to be transferred from the network slave station.

Step 3: — Load the octal address for the data register that will be used to store the data obtained from the slave station.

Step 4: — Insert the RX instruction which specifies the starting address in the slave station. If you are getting the data from a DL305 station, just enter the Data Register number. If you are getting the data from a DL205 or DL405 station, enter a constant that corresponds to the memory address. For example, to get the current count for Timer 600 from a DL305 CPU, you would use R600 with the RX instruction. If you wanted to get Counter 0 from a DL405 CPU, you would use a constant of 1000 with the RX instruction. (V1000 stores the current count for Counter 0 in a DL405 CPU.)

NOTE: The DirectNET manual provides further information on the use of the RX and WX network instructions.

Data Type		D3-330 Range	D3-340 Range	D3-330P Range
	A	aaaa	aaaa	aaaa
Inputs / Outputs	R	000-014 070-075	000-014 070-075	000-014 070-075
Control Relays	R	016-036	016-036 100-105	016, 020-027
Shift Registers	R	040-056	040-056	—
Stages	R	—	—	100-116
Timer /Counters (16 bit)	R	600-677	600-677	600-677
Data Registers	R	400-577	400-577 700-777	400-577
*Constant (4-digit BCD)	K	0000-9999	0000-9999	0000-9999

* A constant is used to obtain data from a DL205 or DL405 system.

Discrete Bit Flags	Description
777	Parameters are not properly set. Check the slave address, data length, or data address reference.
1074	Communication port busy.
1075	Communication error. Data was not transmitted.

NOTE: See the DL205 or DL405 User's Manuals for a listing of V-memory addresses available with these CPUs. Since the DL305 only supports a 4-digit constant, you will not be able to access the entire V-memory ranges of the DL205 and DL405 CPUs. For example, you could not directly access V40400 stored in a DL405 CPU. If you require data from a range outside the area available with a 4-digit constant (from V0 – V9999) then add a routine to the slave station program that moves this data down into one of the accessible areas.

In the following example, when input 001 is on and the CPU busy relay 1074 (see special relays, p. 8-31) is not on, the RX instruction will access a DL405 CPU that has been assigned station address 20. (Note, the D4-DCM slave station addresses are set with switches that indicate a hexadecimal number. Make sure you determine the decimal equivalent to be used with the first DSTR instruction in the sequence.)

Ten consecutive bytes of data (V1400 – V1404) will be read from the slave station and stored in registers R400 – R411. (Remember, the DL205 and DL405 V-memory locations are 16 bits. The DL305 registers are only 8 bits, so you have to use two data registers for each V-memory location.)

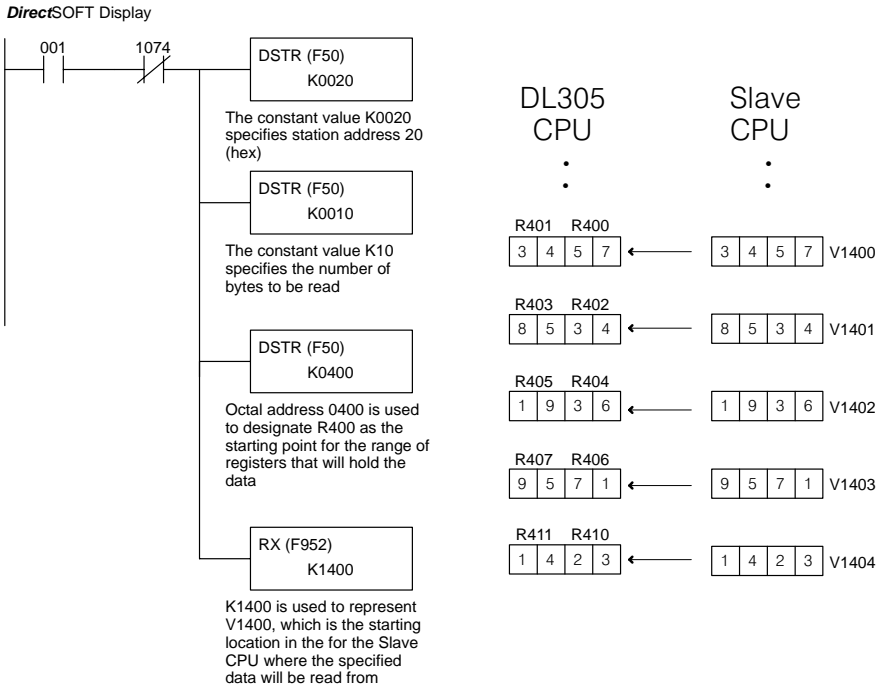

Handheld Programmer Keystrokes

```

STR SHF 1 ENT
AND NOT SHF 1 0 7 4 ENT
F 5 0 ENT
SHF 0 0 2 0 ENT
F 5 0 ENT
SHF 1 0 ENT
F 5 0 ENT
SHF 4 0 0 ENT
F 9 5 2 ENT
SHF 1 4 0 0 ENT
    
```

Write to Network WX (F953) DL340 Only

The Write to Network instruction is used by the master device on a **DirectNET** network to write a block of data to another station. The function parameters are loaded into the accumulator and the first and second level of the accumulator stack by three additional instructions. Listed below are the steps necessary to program the Write to Network function.

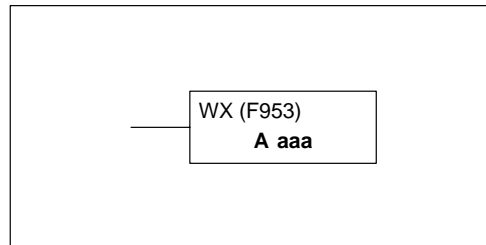

Step 1: — Load the slave address (1–90 BCD) into the accumulator with the DSTR instruction. This must always be preceded by 00, so address 20 would be 0020. (Remember, the D4–DCM slave device addresses are set with switches that use a hexadecimal format. Make sure you convert this address to the decimal equivalent for use with this instruction.)

Step 2: — Load the number of bytes (1 – 128 BCD) to be transferred to the network slave station.

Step 3: — Load the octal address for the data register that will be used to obtain the data that will be sent to the slave station.

Step 4: — Insert the WX instruction which specifies the starting address in the slave station. If you are sending data to a DL305 station, just enter the Data Register number. If you are sending data to a DL205 or DL405 station, enter a constant that corresponds to the memory address. For example, to send data to Register 500 in a DL305 CPU, you would use R500 with the RX instruction. If you wanted to send data to V1400 in a DL405 CPU, you would use a constant of 1400 with the WX instruction.

NOTE: The **DirectNET** manual provides further information on the use of the RX and WX network instructions.

Data Type		D3-330 Range	D3-340 Range	D3-330P Range
A		aaaa	aaaa	aaaa
Inputs / Outputs	R	000-014 070-075	000-014 070-075	000-014 070-075
Control Relays	R	016-036	016-036 100-105	016, 020-027
Shift Registers	R	040-056	040-056	—
Stages	R	—	—	100-116
Timer /Counters (16 bit)	R	600-677	600-677	600-677
Data Registers	R	400-577	400-577 700-777	400-577
*Constant (4-digit BCD)	K	0000-9999	0000-9999	0000-9999

* A constant is used to send data to a DL205 or DL405 system.

Discrete Bit Flags	Description
777	Parameters are not properly set. Check the slave address, data length, or data address reference.
1074	Communication port busy.
1075	Communication error. Data was not transmitted.

NOTE: See the DL205 or DL405 User's Manuals for a listing of V-memory addresses available with these CPUs. Since the DL305 only supports a 4-digit constant, you will not be able to access the entire V-memory ranges of the DL205 and DL405 CPUs. For example, you could not directly access V40400 stored in a DL405 CPU. If you want to send data to a range outside the area available with a 4-digit constant (from V0 – V9999) then add a routine to the slave station program that moves the data from one of the accessible areas into the unavailable locations.

In the following example, when input 001 is on and the CPU busy relay 1074 (see special relays, p. 8-31) is not on, the WX instruction will access a DL405 CPU that has been assigned station address 20. (Note, the D4-DCM slave station addresses are set with switches that indicate a hexadecimal number. Make sure you determine the decimal equivalent to be used with the first DSTR instruction in the sequence.)

Ten consecutive bytes of data (R400 – R411) will be sent from the DL340 and stored in V-memory locations V1400 – V1404. (Remember, the DL205 and DL405 V-memory locations are 16 bits. The DL305 registers are only 8 bits, so you have to use two data registers for each V-memory location.)

DirectSOFT Display

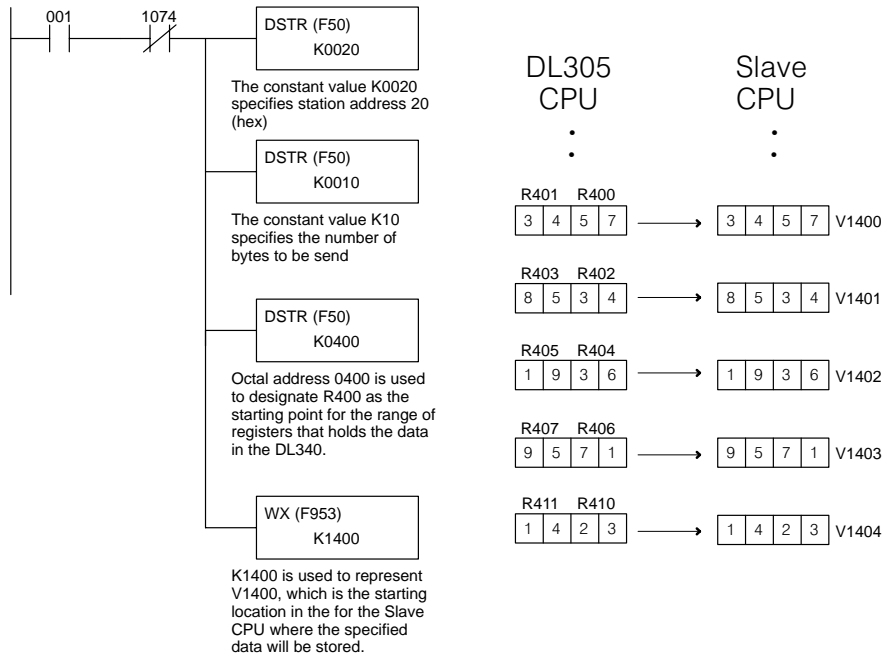

Handheld Programmer Keystrokes

```

STR SHF 1 ENT
AND NOT SHF 1 0 7 4 ENT
F 5 0 ENT
SHF 0 0 2 0 ENT
F 5 0 ENT
SHF 1 0 ENT
F 5 0 ENT
SHF 4 0 0 ENT
F 9 5 3 ENT
SHF 1 4 0 0 ENT
    
```

Message Instructions

Fault FAULT (F20)

The Fault (F20) instruction is used to display a 4-digit BCD constant, 16-bit register, or two consecutive 8-bit data registers on the handheld programmer or in *DirectSoft*. When the fault instruction is executed the number being displayed will also be copied into the registers R574 and R575 and the discrete bit flag 771 will be on.

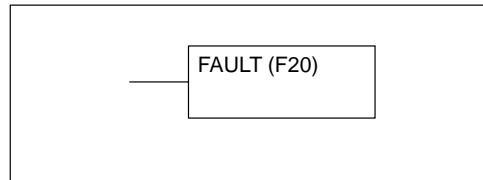

In the following example, when input 000 is on the number 0206 will be displayed on the programming device. This would typically be a user defined error code.

Data Type		D3-330 Range	D3-340 Range	D3-330P Range
A		aaaa	aaaa	aaaa
Inputs / Outputs	R	000-014 070-075	000-014 070-075	000-014 070-075
Control Relays	R	016-036	016-036 100-105	016, 020-27
Shift Registers	R	040-056	040-56	—
Stages	R	—	—	100-116
Timer /Counters (16 bit)	R	600-677	600-677	600-677
Data Registers	R	400-577	400-577 700-777	400-577
Constant (4-digit BCD)	K	0000-9999	0000-9999	0000-9999

DirectSOFT Display

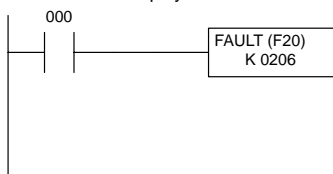

Handheld Programmer Display

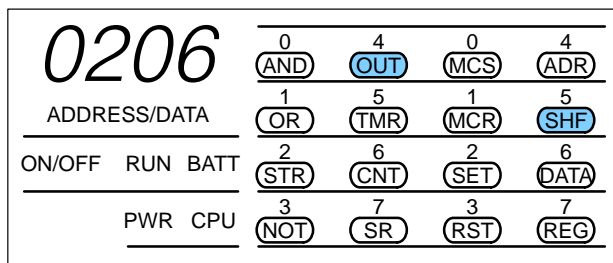

Handheld Programmer Keystrokes

