

# DL330/DL330P/DL340 CPU Specifications

---

## In This Chapter. . . .

- Overview
  - CPU Hardware Features
  - CPU Specifications
  - Selecting CPU Memory Options
  - DL330/DL330P CPU Setup
  - DL340 CPU Setup
  - DL340 Port Setup
  - Battery Backup
  - Installing the CPU
  - CPU Setup and System Functions
-

### Overview

The CPU is the heart of the control system. Almost all system operations are controlled by the CPU, so it is important that it is set-up and installed correctly. This chapter provides the information needed to understand:

- the differences between the different models of CPUs
- the different memory options
- the steps required to setup and install the CPU.

#### DL330 CPU Features

The DL330 modular CPU is capable of controlling 176 I/O points and has 3.7K words of program storage. This CPU supports the RLL programming language and can save programs internally to RAM or UVPROM. There is a built-in programming port that directly supports the handheld programmer.

#### DL330P CPU Features

The DL330P modular CPU is capable of controlling 176 I/O points and has 3.7K words program storage. This CPU supports the RLL<sup>PLUS</sup> programming language and can save programs internally to RAM or UVPROM. RLL<sup>PLUS</sup> provides a structured programming environment for Relay Ladder Logic through the addition of stage logic. There is a built-in port that directly supports the handheld programmer.

#### DL340 CPU Features

The DL340 modular CPU is capable of controlling 184 I/O points and has 3.7K words program storage. This CPU supports the RLL programming language and can save programs internally to RAM, UVPROM or EEPROM. There is a handheld programming port and two built-in RS232C ports for PC programming, operator interfaces, or networking. If you are using the DL340 in a **DirectNET** network, you can use either port as a slave port and the bottom port as a master. The bottom port has the additional capability of being configured as a slave on a Modbus® network.

### CPU Hardware Features

CPU Status Indicators		
RUN	ON OFF	CPU is in RUN mode CPU is in Program mode
BATT	ON OFF	Memory backup voltage low Memory backup voltage good
CPU	ON	CPU failure (Error detected when the watchdog timer is not processed within 100ms. The run output from the power supply will be turned off.) CPU good
	OFF	
PWR	ON	CPU power good CPU power failure
	OFF	
RX	ON	CPU communication port receiving data CPU communication port not receiving data
	OFF	
TX	ON	CPU communication port transmitting data CPU communication port not transmitting data
	OFF	

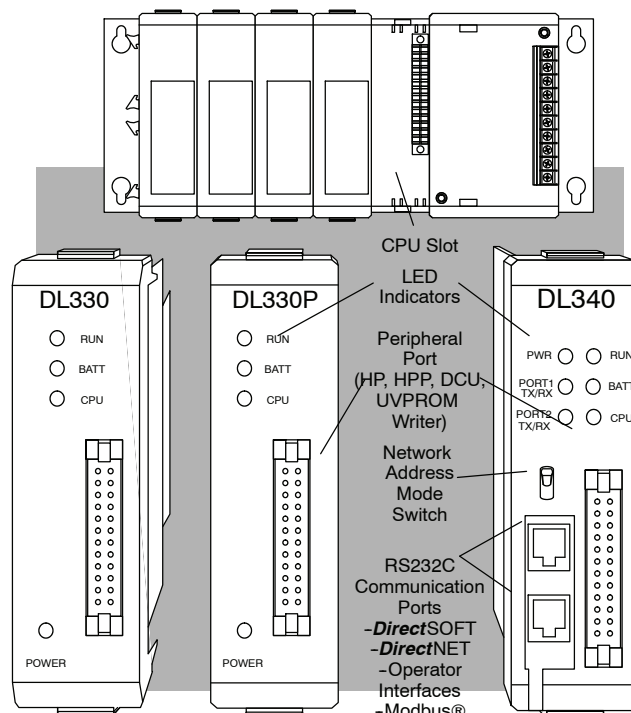

## CPU Specifications

Feature	DL330	DL330P	DL340
Program memory (words)	3.7K	3.7K	3.7K
Scan time/K ladder (boolean)	8 ms	20 ms	.87 ms
Supports Overrides	No	No	Yes
RLL (Relay Ladder Logic) Programming	Yes	Yes	Yes
RLL <sup>PLUS</sup> Programming	No	Yes	No
Handheld programmer with cassette tape interface	Yes	Yes	Yes
<b>DirectSOFT</b> programming for Windows™	Yes	Yes	Yes
Built-in communication ports (RS232C / <b>DirectNET</b> )	No	No	Yes
CMOS RAM	Yes	Yes	Yes
UVPROM	Optional	Optional	Optional
EEPROM	No	No	Optional
Compatible with:			
ASCII Basic modules	Yes	Yes	Yes
Networking modules	Yes	Yes	Yes
RS232C Data Communications Unit	Yes	Yes	Yes
RS422 Data Communications Unit	Yes	Yes	Yes
Base Power Supply Available			
110/220 VAC	Yes	Yes	Yes
24 VDC (5 slot base only)	Yes	Yes	Yes
Total I/O points using;			
Local I/O	128	128	136
Local expansion I/O	176	176	184
Remote I/O	NA	NA	NA
Number of instructions available	61	65	61
Control relays	140	77	196
Shift register bits	128	uses CRs	128
Special relays (system defined)	12	11	20
Stages (RLL <sup>PLUS</sup> only)	None	128	None
Timer/Counters	64	64	64
Data registers	128	128	192
Analog input channels max.	112	112	128
Analog output channels max.	28	28	32
Internal diagnostics	Yes	Yes	Yes
Password security	Yes	Yes	Yes
Battery backup	Yes	Yes	Yes

## Selecting CPU Memory Options

### Internal Retentive Memory

In addition to different choices for program storage, you can also select some memory areas to be retentive. Retentive memory retains its state after a power cycle or a program to run transition occurs, as long as the memory backup battery is functional. Non-retentive memory resets to a logical "0" after a power cycle or a program to run transition occurs. You have to use dipswitch to select the retentive memory options (the switches are discussed in the next section.)

The following table shows the how the types of memory are defined. Some types of memory are automatically defined as retentive and other memory types can be defined as retentive as necessary for your application. The types of memory available depend on the type of CPU selected for your application.

Retentive Memory	Pre-defined	User defined
Application program	Yes	
Stages (DL330P only)		Yes
Internal relays		Yes
Current count values	Yes (full range)	
Shift register bits	Yes (full range)	
Data registers	Yes (full range)	
Password		Yes

### External Program Storage

All DL305 CPUs allow for program storage to be captured on external media such as cassette tape, floppy disk and hard disk. Refer to the DL305 Handheld Programmer manual for details on storing the CPU program to cassette tape. The *DirectSOFT* manual provides details on storing the CPU program to floppy or hard disk.

### Volatile and Non-volatile Memory

There are two types of memory storage available, volatile and non-volatile. Volatile memory will retain your data as long as proper voltage is maintained to the storage media. Non-volatile memory does not require power to retain data. The DL305 CPUs maintain the proper voltage either through the base power supply or the use of the memory backup battery.

### Program Storage Memory Types (Internal)

The type of program storage memory available to you depends on the CPU you are using. All DL305 CPUs support application program storage to either CMOS RAM or the optional UVPROM. The DL340 has the added option of supporting program storage in EEPROM. The application program can be up to 3.7K words.

- CMOS RAM memory (Random Access Memory) is standard on all the DL305 CPUs. It is a volatile memory which can be modified or changed easily with a handheld programmer or PC programming software.
- UVPROM (Ultraviolet Programmable Read Only Memory) is optional for all the DL305 CPUs. This type of memory is non-volatile and can only be erased with an ultraviolet light source. The PROM Writer Unit (D3-PWU) is used to copy your application program from the CPU's RAM to a UVPROM. If the UVPROM has a program to be changed, it must be removed from the CPU and erased before another program can be copied on the UVPROM.
- EEPROM (Electrically Erasable Programmable Read Only Memory) is an option only on the DL340 CPU. This type of memory is non-volatile, but can be electrically erased. The EEPROM can be electrically reprogrammed without being removed from the CPU, and without the use of a special external programming device.



---

**WARNING: Be sure to use proper grounding techniques when touching UVPROMS and EEPROMS. A static discharge from you may cause damage to the PROM. If you do not have a ground strap, then ground yourself by touching the controller chassis before you make contact with the PROM. Also ensure that the surface where you place the PROM is properly grounded.**

---

### Storing Programs on UVPROMs

The PROM Writer Unit is only compatible with DL305 CPUs and UVPROMs. It can perform the following three functions:

- Copy a program from the CPU's RAM to a UVPROM
- Copy a program from the UVPROM to the CPU's RAM
- Compare the program in the UVPROM with the CPU's RAM

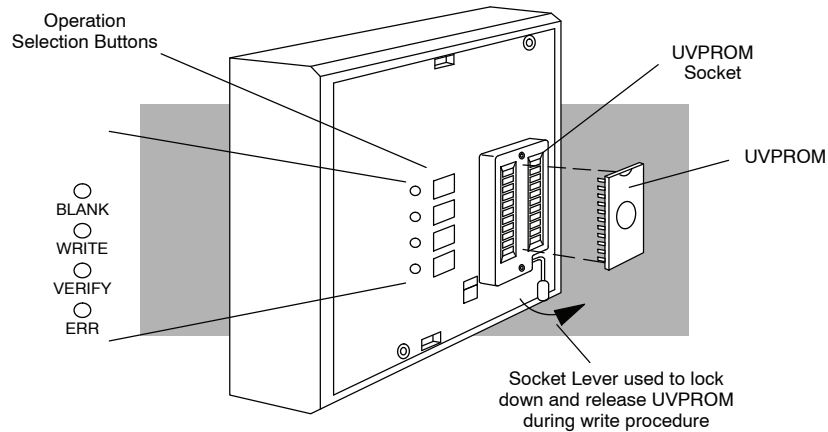

The LED for the selected function will turn off when completed (except for the error reset function). If any error is encountered, one of the LEDs in the following table will be on and the execution of the selected function will be stopped.

Function	Key Operation	LED Display	Remarks	Errors Flagged
Copies the content of the CPU RAM into the UVPROM	WRITE	●WRITE	Automatic comparison is made after checking and writing.	Constant on indicates a write failure.
Copies the content of the UVPROM into the CPU RAM	WRITE VERIFY	●WRITE ●VERIFY	Depress two keys at the same time. Comparison is made after transferring.	
To verify the content of the UVPROM with the CPU RAM	VERIFY	●VERIFY		Constant on indicates an unmatched address.
To check if the UVPROM is blank.	BLANK	●BLANK		Constant on indicates a non-blank address is found.
Error reset	ERR	●ERR	Return to the initial condition by pressing this key if an error condition is noted.	On indicates an error.
		●CPU	Red	On indicates failure.
		●PWR	Green	On indicates DC power is within tolerance. Off indicates DC power not within tolerance.

### Setting up the PROM Writer Unit

The PROM Writer Unit connects directly to either a DL330, DL330P or DL340 CPU. Use the following steps to connect the PROM Writer Unit:

1. Set the power supply source switch (on the back of the unit) to the appropriate power source setting, (INT for using base power and EXT for an external power source). The PROM Writer Unit can either use the local CPU base power or use an external power source.

**NOTE:** If you are using the local CPU base power you will need to include the Prom Writer Unit power consumption in your power budget. The power budget is covered in Chapter 4.



2. If using an external power source attach the supplied cable to the power source socket on the back of the unit. The white wire should be connected to +5VDC and the black wire should be connected to DC ground.
3. Turn off the power source to the base before attaching the PROM Writer Unit.
4. Attach the PROM Writer Unit to the CPU. The connector on the back of the unit will mate with the programming port (PRG) of the CPU. Tighten the fixture screw to secure the two units together.
5. Apply power to the local CPU base and if necessary to the PROM Writer Unit. Once the PWR LED is on it will take approximately 10 seconds for the unit to initialize. During this time keystrokes will not be recognized.

### Copying a Program From the CPU RAM to a UVPROM

The following steps explain how to copy a program from the CPU RAM to a UVPROM:

1. Turn power on.
2. Raise the UVPROM socket lever.
3. Insert the UVPROM (notch up) in the socket and lower the lever.
4. Press the "WRITE" button. The following sequence of events will take place:
  - The WRITE LED will turn on then off.
  - The BLANK LED will come on. (This notes the checking sequence to ensure that the UVPROM is blank has started.)
  - The BLANK LED will turn off and the WRITE LED will turn on.
  - The WRITE LED will turn off and the VERIFY LED will turn on. (This indicates that the write is complete. While the VERIFY LED is on, a comparison between the UVPROM and the CPU RAM is being made.)
  - The VERIFY LED will turn off. (This indicates the end of the copying function.)
  - If an error has been detected, the ERR LED will come on. If this happens press the "ERR" key to clear the error and the "WRITE" key to repeat the procedure. If this does not correct the problem, repeat the procedure using a different UVPROM.
5. Turn power off, raise the UVPROM socket lever and remove UVPROM.

**Copying a Program From the UVPROM to the CPU RAM** The following steps explain how to copy a program from the UVPROM to the CPU RAM:

1. Turn power on.
2. Raise the UVPROM socket lever.
3. Insert the UVPROM (notch up) in the socket and lower the lever.
4. Simultaneously press "WRITE" and "VERIFY" buttons. The following sequence of events will take place:
  - The BLANK, WRITE and VERIFY LEDs will all come on momentarily.
  - The WRITE LED turns off.
  - The VERIFY LED will stay on till the operation is completed.
  - If an error has been detected, the ERR LED will come on. If this happens, press the "ERR" key to clear the error and repeat step 4.
5. Turn power off, raise the UVPROM socket lever and remove UVPROM.

**Comparing a Program From the UVPROM to the CPU RAM**

The following steps show how to compare a UVPROM program to the CPU RAM:

1. Turn power on.
2. Raise the UVPROM socket lever.
3. Insert the UVPROM (notch up) in the socket and lower the lever.
4. Press the "VERIFY" button. The following sequence of events will take place:
  - The VERIFY LED indicator will come on.
  - If verification is successful, the VERIFY LED will go off.
  - If there is an error in the comparison the VERIFY LED will remain on.
5. Turn power off, raise the UVPROM socket lever and remove UVPROM.

**Erasing a UVPROM** UVPROMS can be erased through exposure to an ultraviolet light source. Make sure that the window to the UVPROM is not covered so that it may receive full exposure to the light source. A typical exposure would be: 12,000 $\mu$  w/cm<sup>2</sup> lamp @ 2.5 cm for 15-20 minutes.

# DL330/DL330P CPU Setup

## Installing the UVPROM Option in the DL330 / DL330P CPU

- Disconnect the power from the base and allow approximately 60 seconds for the capacitor to discharge before removing the CPU.
- Disconnect the battery wires from the CPU.
- Remove the RAM chip from IC socket.
- Align the UVPROM notch with the IC socket notch on the CPU card.
- Carefully insert the UVPROM in the IC socket.
- Set dip switch 2 and Jumpers 1 - 3 for UVPROM (ROM).
- Reconnect the battery wires to CPU.

Memory Type / Switch	RAM	UVPROM (ROM)
JUMPER 1		
JUMPER 2		
JUMPER 3		
DIPSWITCH 2		

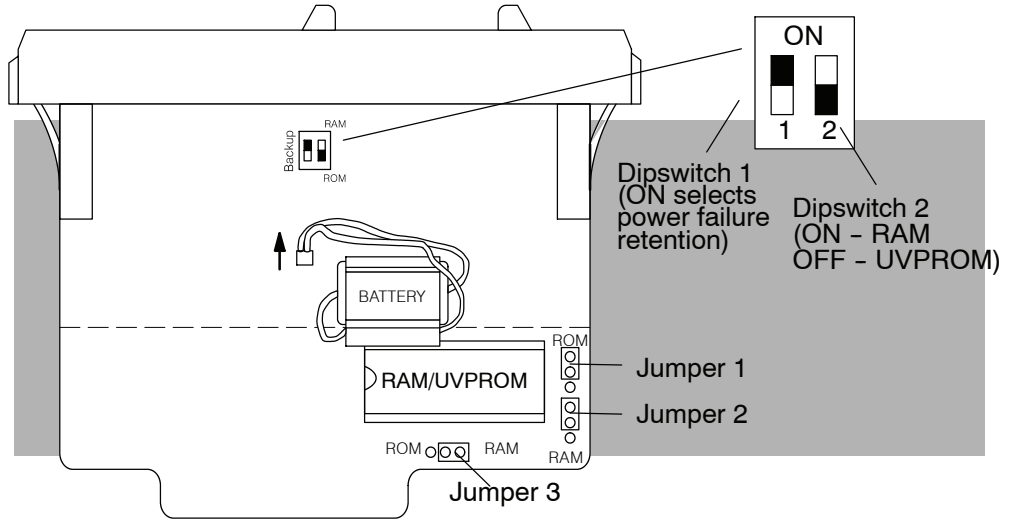

## Selecting Retentive Memory for the DL330 / DL330P

The DL330 and DL330P have a dipswitch which can be used to turn on or off power failure retention for specific relays and stages. (Some memory types are automatically retentive.) The following diagram lists the range of retentive memory for the memory types that are covered by the selection switch.

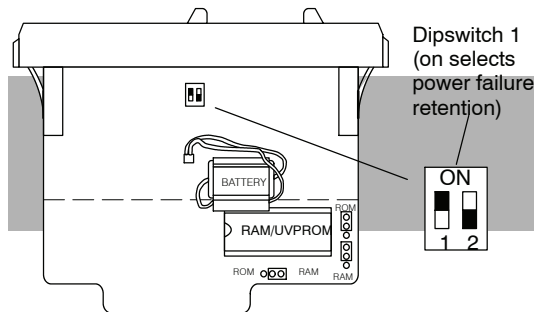

**Internal relays in the DL330** range from 160 - 373, only 340 - 373 can be set retentive or non-retentive.

**Internal relays in the DL330P** range from 160 - 277, only 200 - 277 can be set retentive or non-retentive.

**Stages in the DL330P** range from SG000 to SG177, only SG000 to SG137 can be set retentive or non-retentive.

## DL330/DL330P Networking

Networking for the DL330 and DL330P is accomplished by using a DCU, (Data Communications Unit, RS232C part number D3-232-DCU, RS422 part number D3-422-DCU).

DL330/DL330P/DL340 CPU Specifications

## DL340 CPU Setup

### Installing the optional UVPROM or EEPROM in the DL340 CPU

Complete the following steps to install the optional memory.

1. Disconnect the power from the base and allow approximately 60 seconds for the capacitor to discharge before removing the CPU.
2. Disconnect the battery wires from the CPU.
3. Align the UVPROM/EEPROM notch with the IC socket notch on the CPU.
4. Carefully insert the UVPROM/EEPROM into the IC socket.
5. Set dipswitch SW1, bit 1 and the short Jumpers N/C - 4 for the option you have installed.
6. Reconnect the battery wires to the CPU.

Memory Type Switch	RAM	EEPROM	EEPROM (WRITE PROTECTED)	UVPROM (ROM)
DIPSWITCH SW1 - Bit 1				
SHORT PIN JUMPERS				

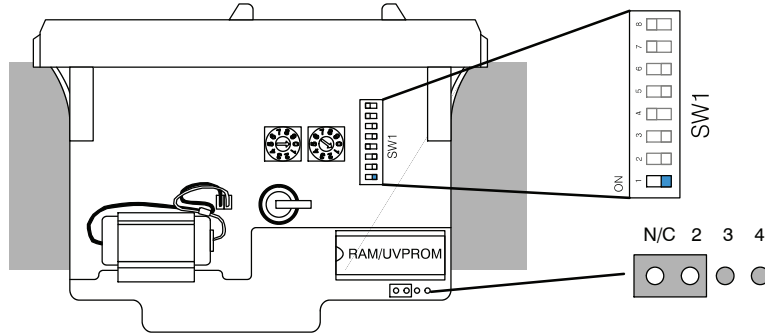

DL330/DL330P/DL340 CPU Specifications

**Selecting Retentive Memory for the DL340**

The DL340 uses the same dipswitch for selecting memory retention as was used for memory type selection. Dipswitch SW1, bit 2 is used to set memory retention for the ranges of internal relays shown in the following diagram.

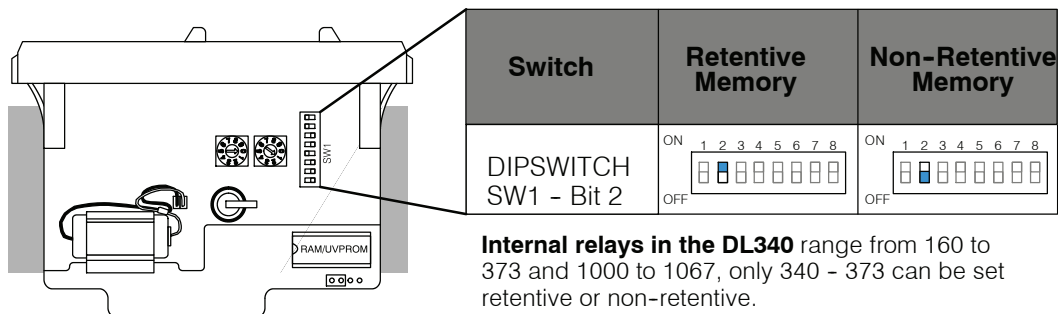

### DL340 Port Setup

#### DL340 Baud Rate Selection

The following chart shows how to configure the baud rate for Port 1 (RS232C) of the DL340 using dipswitch SW1, switches 3, 4 and 5. Port 2 baud rate is set by using a programming device to enter the baud rate in address R773 (in BCD or HEX).

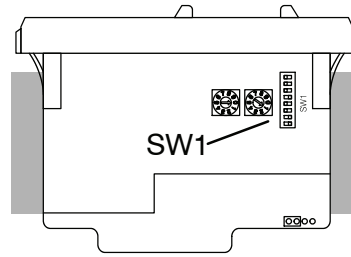
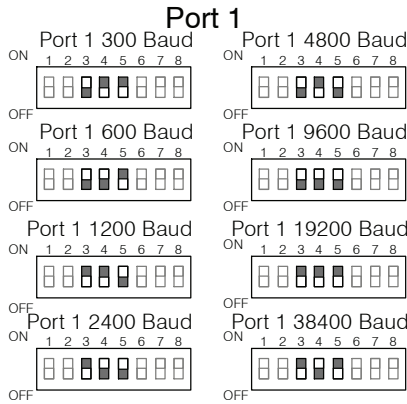

Port 2	
Baud	R773
300	1
600	2
1200	3
2400	4
4800	5
9600	6
19200	7
38400	8
9600	0, 9 to FF

#### Sample Setup Ladder Logic

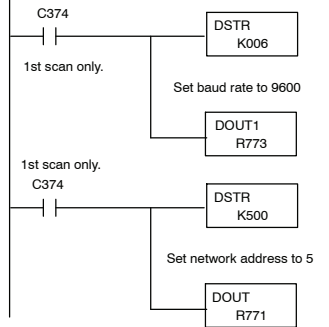

#### DL340 Network Address Selection

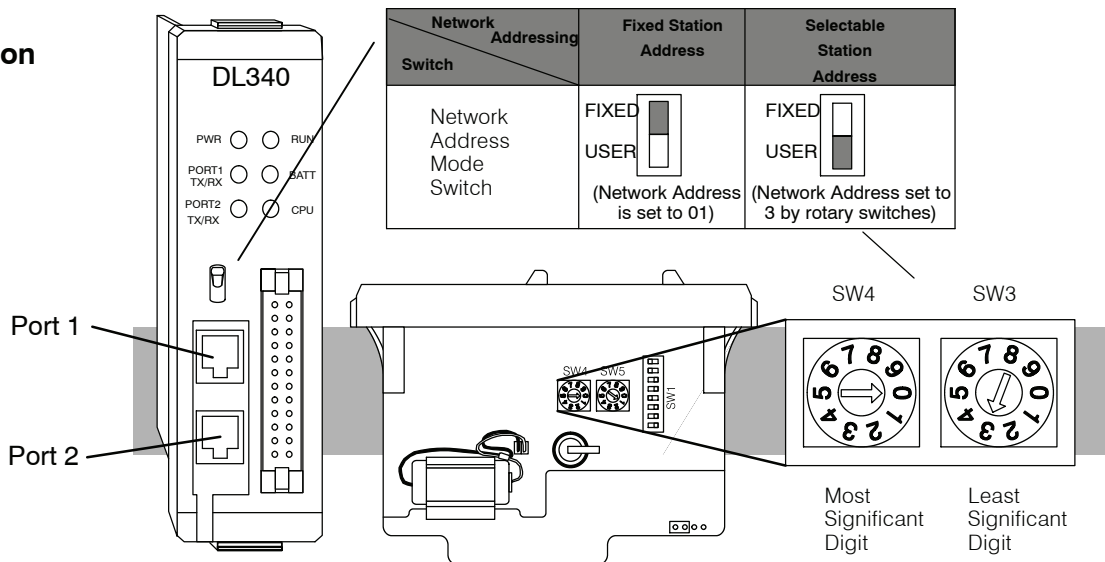

**Port 1 (RS232C):** Network address selection is accomplished with the Network Address Mode Switch and the two rotary switches 3 and 4. The address is set in BCD.

Network Address Mode Switch sets fixed or selectable network address.

Rotary Switch 3 sets the least significant decimal digit of the network address.

Rotary Switch 4 sets the most significant decimal digit of the network address.

In the example above, when the Network mode switch is set to FIXED the network address will default to 01, when the Network mode switch is set to USER the network address (set with the rotary switches) is 03. Note, if the rotary switches are set to 00, the network address will default to 01.

**Port 2 (RS232C):** Network address selection is set by using a programming device to enter the value for the most significant digit and least significant digit in addresses R771 and R772 respectively. The address is set in BCD.

If you're using MODBUS RTU protocol on Port 2, the MODBUS address is set in decimal, not BCD. Load the lower two digits in R771 and the upper two digit(s) in R772.

**DL340 RS232C Port (1 and 2) Pin Outs**

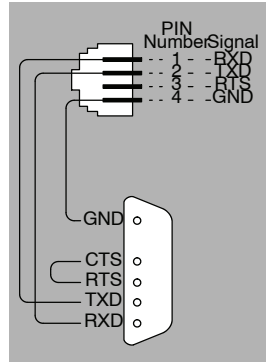

RS232C Communication Port Specifications	
Connector	-----RJ11 (handset connector)
Network Address	-----01 to 90
Baud Rate	-----38400, 19200, 9600, 4800, 2400, 1200, 600, 300
Parity	-----None / Odd
Transfer Mode	-----Hex / ASCII
	-----Half-duplex
	-----Asynchronous
Data bits	-----8
Start bits	-----1
Stop bits	-----1
Turn Around Delay	-----0 to 1980 in 20 ms intervals (preset with R777)

**DL340 Station Type Selection and Address Ranges**

The station type for Port 1 is fixed as a Slave and cannot be changed. The station type for Port 2 can be selected by setting the appropriate switch positions (6 and 7) on the SW1 switch bank.

Port	Bit 6	Bit 7	Protocol	Address Range
1	N/A	N/A	Slave	1 - 90
2	Off	Off	Slave/ <i>DirectNET</i>	1 - 90
	Off	On	Master/ <i>DirectNET</i>	1 - 90
	On	Off	Peer/ <i>DirectNET</i>	1 - 90
	On	On	Modbus®/RTU	1 - 247

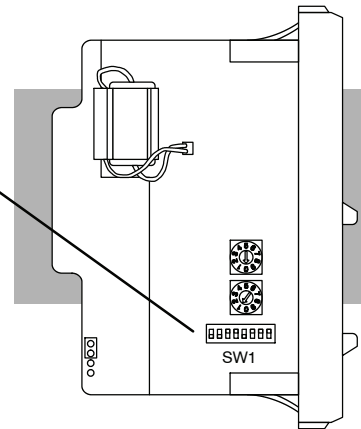

**DL340 Selecting the Response Delay Time**

You can use the Handheld Programmer or *DirectSOFT* to select an on and off response delay time of up to 1980 ms. The time delay is calculated based on a preset number that is loaded into two memory locations. These presets indicate the number of 20 ms intervals that will be used as the delay. For example, an entry of 2 would result in a 40 ms response delay time.

Port	On Delay	Off Delay
Port 1	R776	R777
Port 2	R774	R775

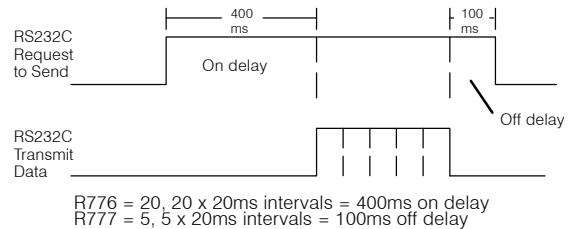

**DL340 Selecting Data Format (ASCII/HEX)**

A special propose control relay is used to select between ASCII and HEX transmission modes on the *DirectNET* network. When this relay is off, HEX mode is used. When this relay is turned on, ASCII mode is used. Off is the default state.

- Port 1 C1077
- Port 2 C1076

**DL340 Selecting Parity for Port 2**

DL340 CPUs with firmware V2.7 or later allow you to select the parity for Port 2. The default setting is none. A special propose control relay (C1072) is used to select between odd parity (relay is on) and no parity (relay is off).

- Port 2 C1072

DL330/DL330P/DL340 CPU Specifications

## Battery Backup

### Memory Battery Backup

The DL305 CPUs have a lithium battery to retain the application program and retentive memory when the system is not receiving power from the power supply. Typical battery life is five years. This time period includes PLC runtime and normal shutdown periods such as preventative maintenance and power outages.

The CPU has indicators which tell when it is necessary to change the battery. However, if your battery has been in your system for an extended period of time, you may wish to take added precautions to ensure that the system memory will be retained by installing a new battery when shutting the system down for a period of more than ten days.



**NOTE:** Before replacing your CPU battery, you should back-up your application program. This can be done by saving the program to hard/floppy disk on a personal computer or using the handheld programmer along with a cassette tape recorder. The CPU has a built-in capacitor to retain the memory for several minutes while the battery is being replaced.



**WARNING:** If the battery connector is not connected to the PC board or the battery is not installed, the indicator will not notify you of the error. Be sure the battery is in place and the connector is firmly seated before you install the CPU into the base.

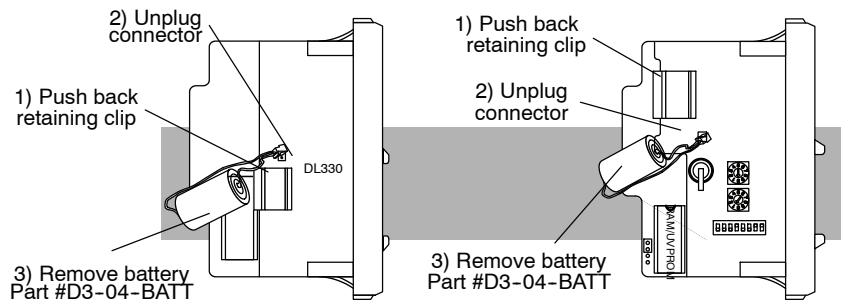

### DL330, DL330P, DL340 CPU Battery Replacement

To replace the CPU battery:

1. Turn power off to the system.
2. Wait 60 seconds then remove the CPU. Do not short any connectors or components on the CPU since it may alter the program memory.
3. Unlatch and tilt the clip covering the battery.
4. Pull the two wire battery connector from the PC board and remove the battery.



**WARNING:** Do not attempt to recharge the battery or dispose of it by fire. The battery may explode or release hazardous materials.

To install the CPU battery:

1. Plug the (keyed) two wire battery connector on the battery into the connector on the PC board.
2. Push gently till the connector snaps closed
3. Slide the battery under the battery retaining clip till the battery is positioned in the socket.
4. Push the retaining clip down over the battery snapping the clip over the edge of the PC board.
5. Note the date the battery was changed.

## Installing the CPU

Before you complete these steps, make sure you have set the dipswitches and/or jumpers needed to support your application.

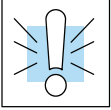

**WARNING:** To minimize the risk of electrical shock, personal injury, or equipment damage, always disconnect the system power before installing or removing any system component.

When inserting the CPU into the base, align the PC board with the grooves on the top and bottom of the base. Push the CPU straight into the base until it is firmly seated in the backplane connector.

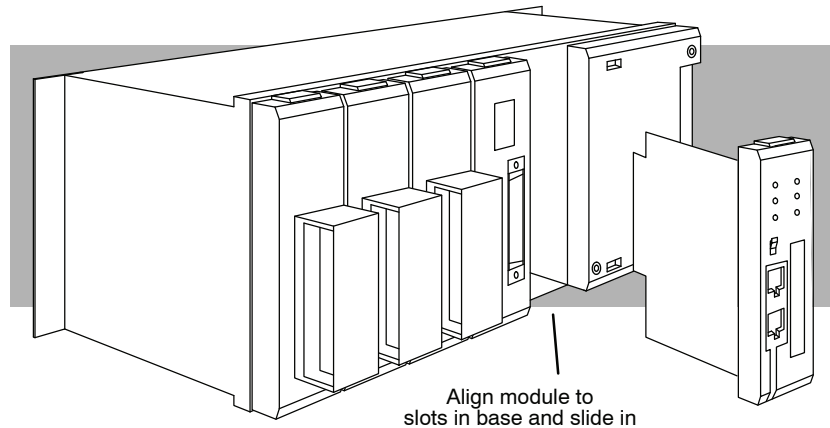

## CPU Setup and System Functions

### A Few Things to Know

Even if you have years of experience using PLCs, there are a few things you need to do before you can start entering programs. This section includes some basic things, such as changing the CPU mode and connecting a programming device. Here is a list of the items that are discussed.

- Auxiliary Functions
- Connecting a Programming Device
- Changing the CPU Modes
- Clearing the CPU memory

The following paragraphs provide the setup information necessary to get the CPU ready for programming. The actual setup information depends on the type of programming device you are using. For example, the DL305 Handheld Programmer manual provides the Handheld keystrokes required to perform all of these operations. The *DirectSOFT* manual provides a description of the menus and keystrokes required to perform the setup procedures via *DirectSOFT*.

## What are Auxiliary Functions?

Many CPU tasks involve the use of predefined functions. These are often called Auxiliary (AUX) Functions. The AUX Functions perform many different operations, ranging from simple operating mode changes to determining the firmware revision number.

You can access all of the AUX Functions from *DirectSOFT* menu options, but not from the DL305 Handheld Programmer. You can still perform some of the operations with the Handheld Programmer, but they are accomplished by using a certain series of keystrokes rather than by entering a specific AUX function.



**NOTE:** Neither *DirectSOFT* or the Handheld Programmer utilize the numbers shown for the AUX functions. These numbers have been included because many of you may already have existing software packages that can be used with these CPUs. If you do already have an existing software package, remember that any additional features (such as added I/O, CRs, etc. available with the DL340 CPU) may not be accessible.

AUX Function and Description		DL330, DL330P, DL340	
<b>AUX 1* — Diagnostics and PLC Modes</b>		<b>Software</b>	<b>HP</b>
10	Program Syntax Check (Grammar check)	○	○
11	Compare PLC to Disk	○	×
12	PLC Operational Mode	○	○
13	Revision Number	○	×
<b>AUX 3* — Clear PLC Memory</b>		<b>Software</b>	<b>HP</b>
31	Ladders	○	○
32	Data Registers	○	×
33	Timer / Counter Accumulators	○	×
<b>AUX 6* — Save Data from PLC</b>		<b>Software</b>	<b>HP</b>
61	Ladders	○	○
62	Data Registers	○	×
<b>AUX 9* — Load Data to PLC</b>			
91	Ladders	○	○
92	Data Registers	○	×
<b>Password Operations</b>			
None	Password	○	○

○ — Function or keystrokes available

× — Not available

**Connecting the  
Programming  
Devices**

You can mount the Handheld directly to the port of the CPU, or you can use a cable. The cable, part number D3-HPCBL, is approximately 4.5 feet (1.5m) in length and provides more flexibility. There are two different handheld programmers for the DL305 CPUs. The D3-HP can be used with either the DL330 or the DL340. The D3-HPP can only be used with the DL330P. The D3-HPP supports the RLL<sup>PLUS</sup> features.

If you're using a Personal Computer with the **DirectSOFT** programming package, a Data Communications Unit (either RS232C or RS422) must be used to interface to the DL330/DL330P CPUs. DCUs may also be used to establish a connection between the DL305 and an operator interface or a network.

The DL340 CPU provides two built-in RS232C ports which can be used to directly connect to a personal computer, operator interface or network. The DCU may also be used with the DL340 if the built-in ports are otherwise occupied.

**Programming the DL340 CPU with either the Handheld programmer or the PC**

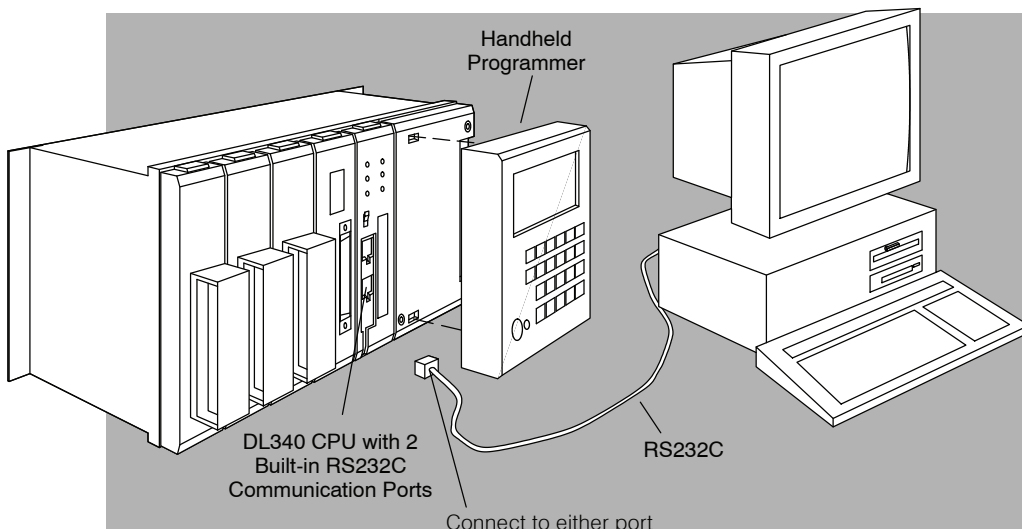

**Programming the DL330 CPU with either the Handheld programmer or the PC (using a Data Communication Unit)**

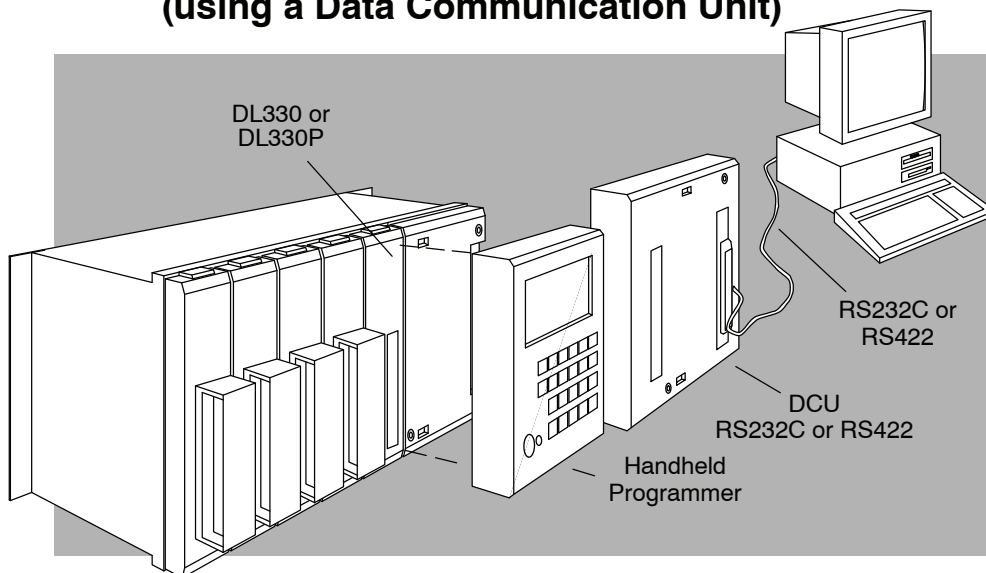

DL330/DL330P/DL340 CPU Specifications

### Changing the CPU Mode of Operation

There are two modes of operation for the DL305 CPUs:

- RUN — executes the application program and updates I/O modules
- PGM — allows program entry, does not execute the application program or update I/O modules

The CPU modes for all DL305 CPUs can be changed by using either a Handheld Programmer or *DirectSOFT*. The DL330 and DL330P require a Data Communications Unit when using *DirectSOFT*. This is discussed later in this chapter.

Since the DL340 has the possibility of being accessed through multiple ports at the same time, the Handheld Programmer and DCU have priority over the built-in RS232C ports during mode change operations. If no Handheld Programmer or DCU is online, *DirectSOFT* can perform mode changes through either of the built-in ports. When the Handheld Programmer or DCU is online and a mode change is attempted with *DirectSOFT*, the Handheld Programmer or DCU will immediately change the mode back to the original mode. This forces the CPU mode to always correspond with the keyswitch position on the Handheld Programmer.



**WARNING:** The CPU will automatically change modes when you connect the Handheld Programmer if the keyswitch is set for a different mode of operation. For example, if the CPU is in Run mode and the Handheld Programmer keyswitch is set to the PRG (Program) position, the CPU will automatically enter Program mode when the Handheld is connected.

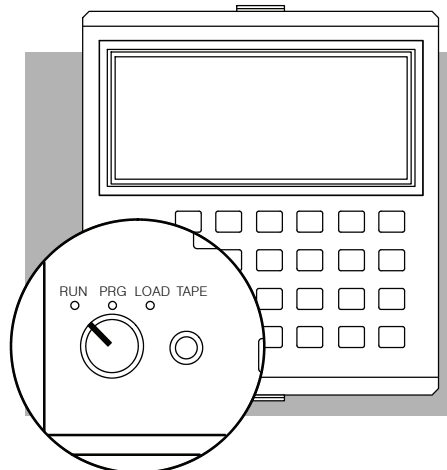

The LOAD position is used for uploading a program from CPU memory to a cassette tape, or downloading a program from cassette tape to CPU memory.

**Clearing the CPU Memory**

Before you enter a new program, you should always clear the CPU memory. Only a few keystrokes are required. The next few steps show how to clear the CPU memory using the handheld programmer.

Put the handheld programmer's key switch in the PRG position. Attach the handheld programmer directly to the front of the CPU making sure that the port on the back of the programmer aligns properly with the port on the CPU and the programmer's latches connect with the slots in the base power supply. Apply power to the base. LED's on the programmer will display indicating a good connection.

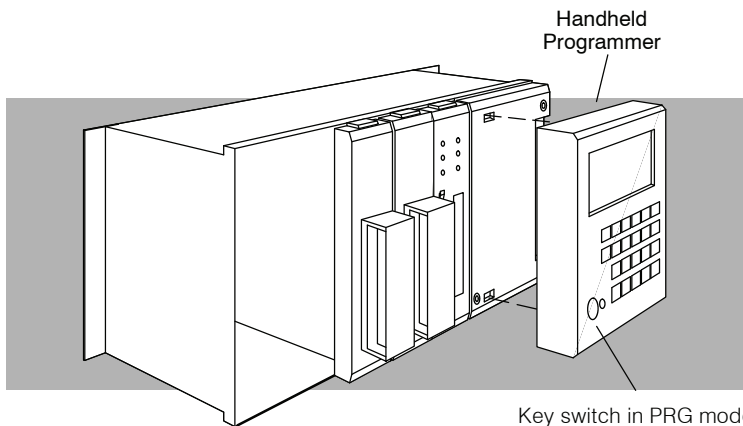

You can clear the memory by using the PLC/Clear PLC sub-menu from within *DirectSOFT*, or you can use the following Handheld Programmer keystrokes.

<b>CLR</b>	0	4	0	4
	(AND)	(OUT)	(MCS)	(ADR)
	1	5	1	5
	(OR)	(TMR)	(MCR)	(SHF)
ON/OFF	RUN	BATT		
	2	6	2	6
	(STR)	(CNT)	(SET)	(DATA)
PWR	CPU			
	3	7	3	7
	(NOT)	(SR)	(RST)	(REG)

CLR SHF 3 4 8 DEL NXT (Clears the CPU memory)

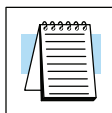

**CPU Checklist**

Before you proceed with the I/O configuration or programming information, make sure you have:

- set the CPU dipswitches
- selected and installed the EEPROM/UVPROM (if chosen.)
- a good understanding of the various system functions needed to setup the CPU.

DL330/DL330P/DL340 CPU Specifications

