

I/O Module Selection & Wiring Guidelines

In This Chapter. . . .

- I/O Selection Considerations
 - Sinking and Sourcing Circuits
 - DL305 Input Module Configuration Chart
 - DL305 Output Module Configuration Chart
 - Configuration #1 DL305 DC Current Sourcing Input Module
 - Configuration #2 DL305 DC Current Sinking/Sourcing Input Module
 - Configuration #3 DL305 DC Current Sinking Input Module
 - Configuration #4 DL305 AC/DC Input Module
 - Configuration #5 DL305 AC Input Module
 - Configuration #6 DL305 DC Current Sinking Output Module
 - Configuration #7 DL305 DC Current Sourcing Output Module
 - Configuration #8 DL305 AC/DC Current Sink/Source (Relay) Output Module
 - Configuration #9 DL305 AC Output Module
 - Solid State Field Device Wiring to DC Input Modules
 - Derating Characteristics
 - I/O Wiring Guidelines
 - Fuse Protection
-

I/O Selection Considerations

I/O Module Selection

The DL305 product family offers various types of I/O modules for interfacing many different field devices to the PLC system. There are several electrical characteristics that should be considered when choosing the proper I/O module for a field device or for obtaining required system performance. Electrical characteristics for discrete input modules and discrete output modules are discussed in Chapters 6 and 7. The DL305 family also offers several specialized modules such as analog, ASCII BASIC modules, network interface modules, high speed counter modules, etc. These modules have their own manuals, so if you are using them you should supplement this manual with the manual specifically designed for the special module.

Sinking and Sourcing Circuits

The charts on the following page supply information on the current sinking and current sourcing configurations using DL305 discrete I/O modules. If you have a question about the type of device required to connect to a particular module please refer to the following charts. The charts show nine common input and output module configurations. Match the module part number you are considering to the applicable configuration(s) to ensure the module type will work in your application.

For additional clarification we have included nine diagrams depicting the configurations listed in the charts. These diagrams show the module category, type of device and how they are connected to each other. The diagrams and two examples of wiring a solid state switch to an input module follow the charts on the next page.

DL305 Input Module Configuration Chart

DL305 Input Module Type	Config #1 DC Current Sourcing Input	Config #2 DC Current Sink/Source Input	Config #3 DC Current Sinking Input	Config #4 AC/DC Input	Config #5 AC Input
D3-16ND2-1	✓				
D3-16ND2-2*	✓				
D3-16ND2F	✓				
F3-16ND3F		✓			
D3-08ND2	✓				
D3-08NA-1					✓
D3-08NA-2					✓
D3-16NA					✓
D3-08NE3	✓	✓	✓	✓	✓
D3-16NE3	✓	✓	✓	✓	✓

DL305 Output Module Configuration Chart

DL305 Output Module Type	Config #6 DC Current Sinking Output	Config #7 DC Current Sourcing Output	Config #8 AC/DC Current Sink/Source Output	Config #9 AC Output
D3-04TD1	✓			
D3-08TD1	✓			
D3-08TD2		✓		
D3-16TD1-1	✓			
D3-16TD1-2*	✓			
D3-16TD2		✓		
D3-08TA-1				✓
D3-08TA-2				✓
F3-16TA-1*				✓
F3-16TA-2				✓
D3-16TA-2				✓
D3-08TR			✓	
F3-08TRS-1			✓	
F3-08TRS-2			✓	
F3-08TRS-4			✓	
D3-16TR			✓	
D3-04TAS				✓
F3-08TAS*				✓
F3-08TAS-1				✓

* Obsolete

Configuration #1 DL305 DC Current Sourcing Input Module

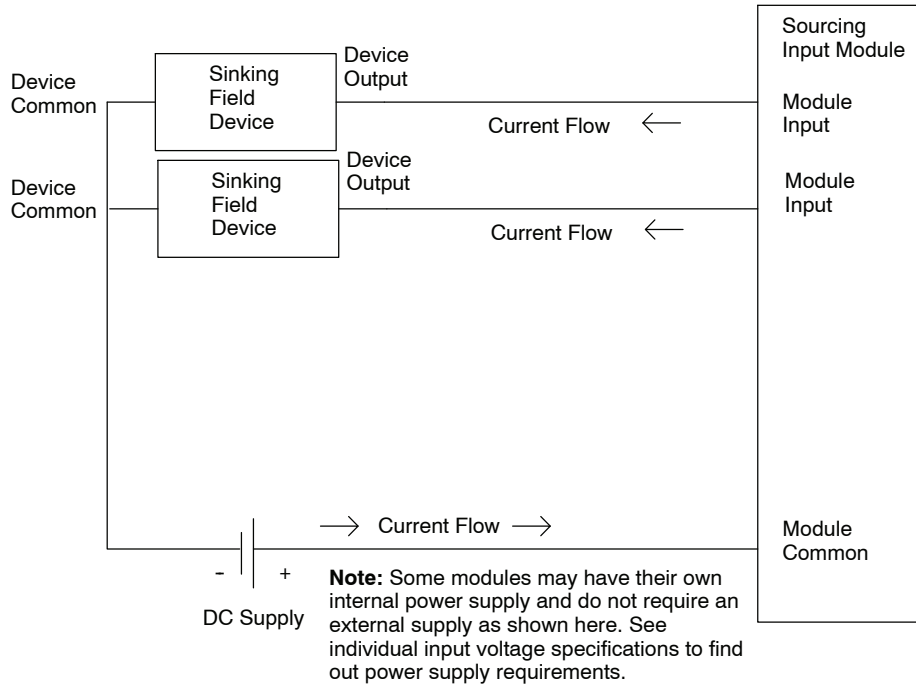

Configuration #2 DL305 DC Current Sinking/Sourcing Input Module

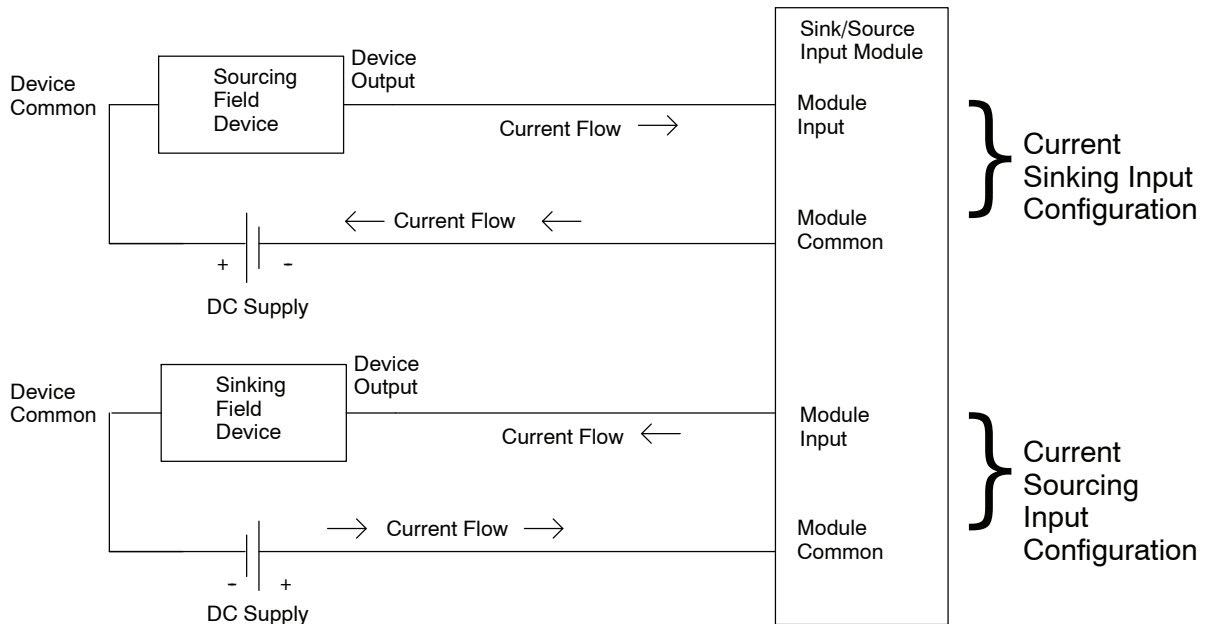

Configuration #3 DL305 DC Current Sinking Input Module

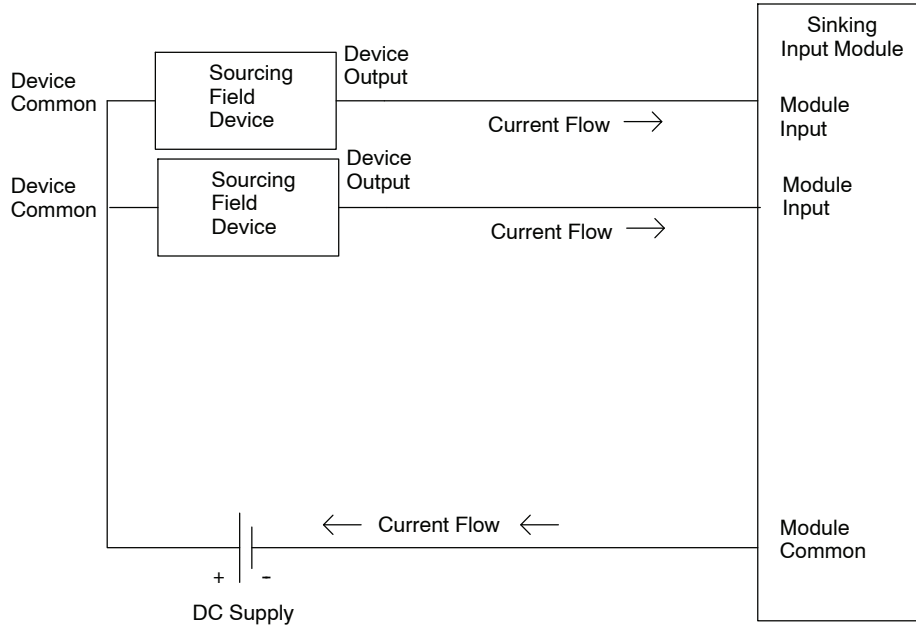

Configuration #4 DL305 AC/DC Input Module

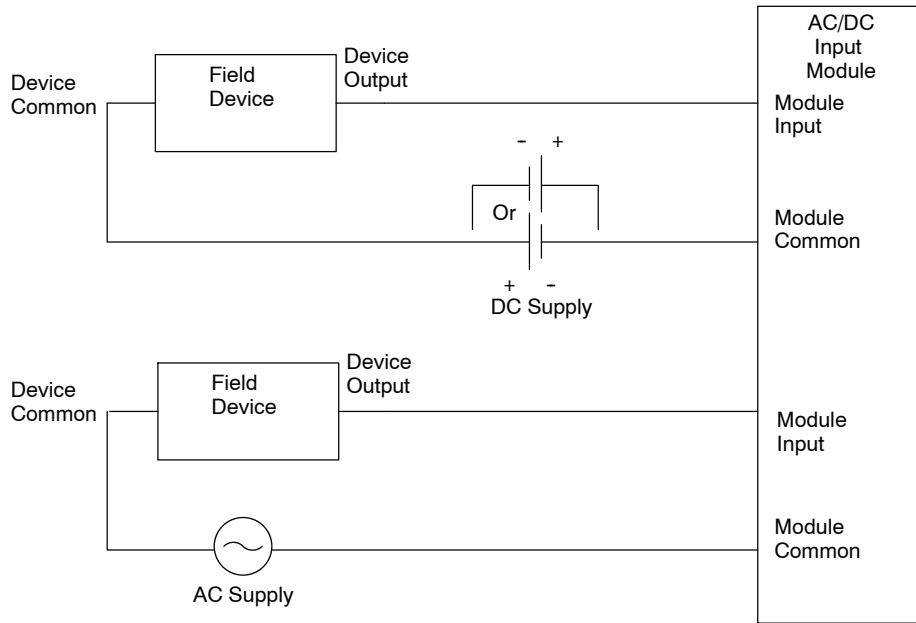

Configuration #5 DL305 AC Input Module

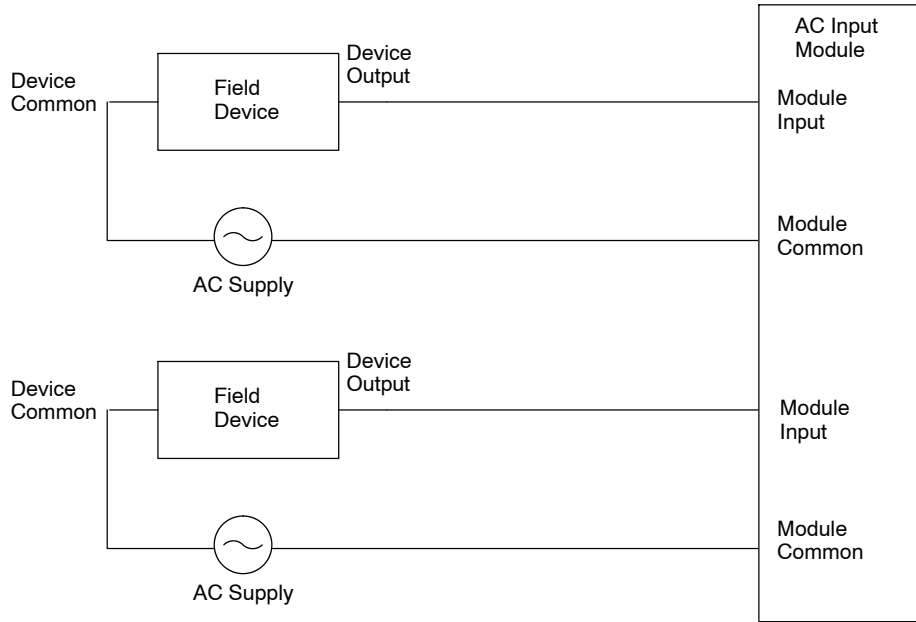

Configuration #6 DL305 DC Current Sinking Output Module

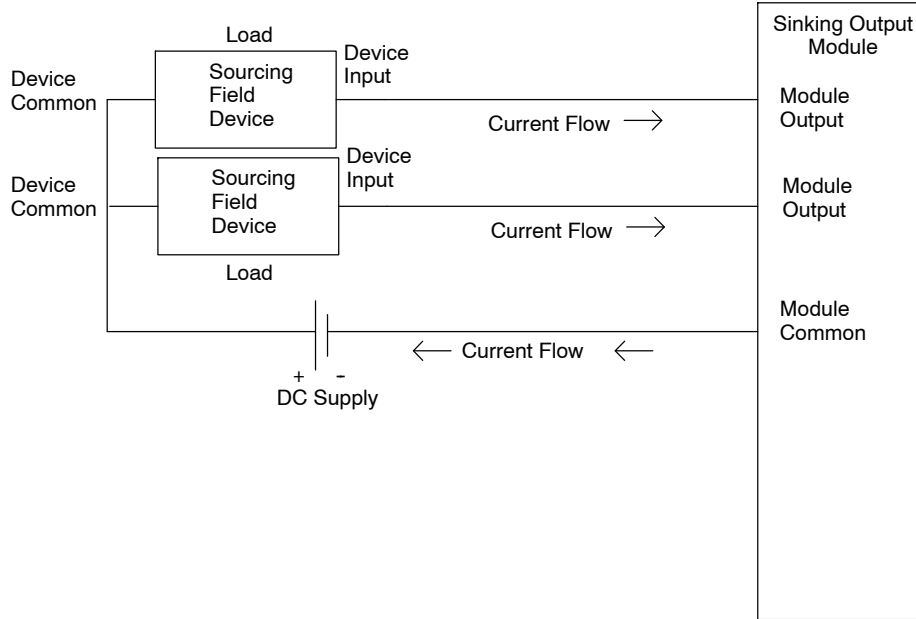

Configuration #7 DL305 DC Current Sourcing Output Module

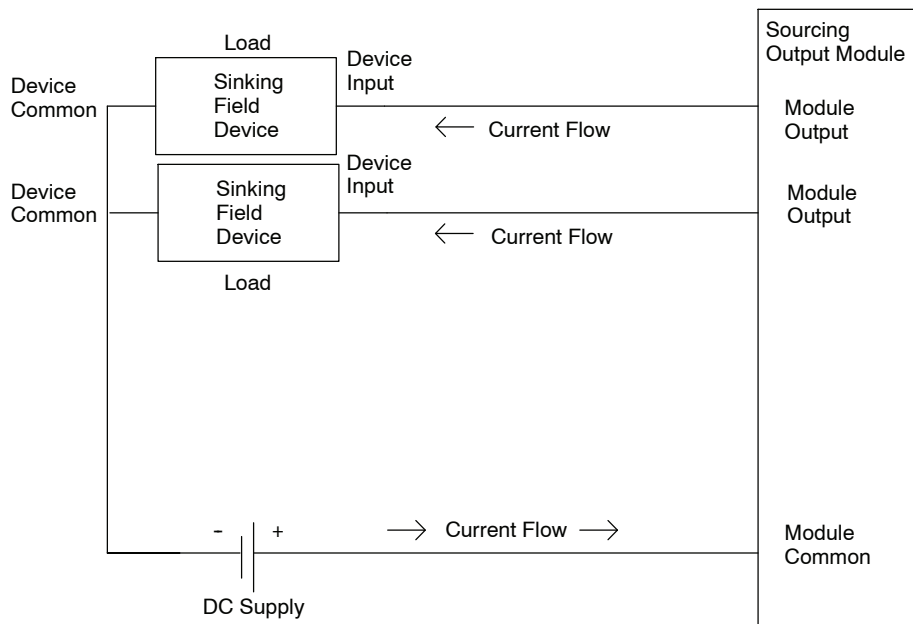

Configuration #8 DL305 AC/DC Current Sink/Source (Relay) Output Module

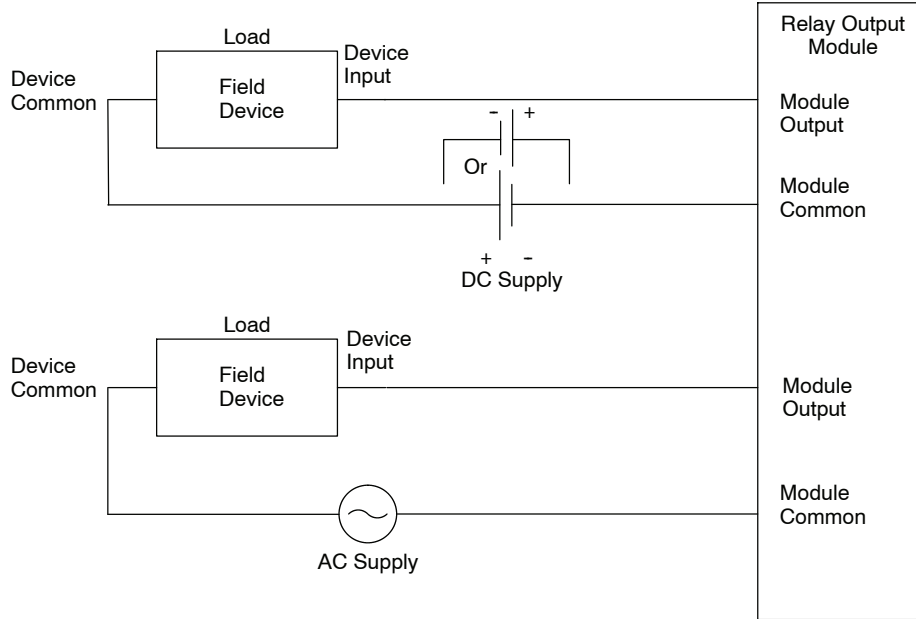

Configuration #9 DL305 AC Output Module

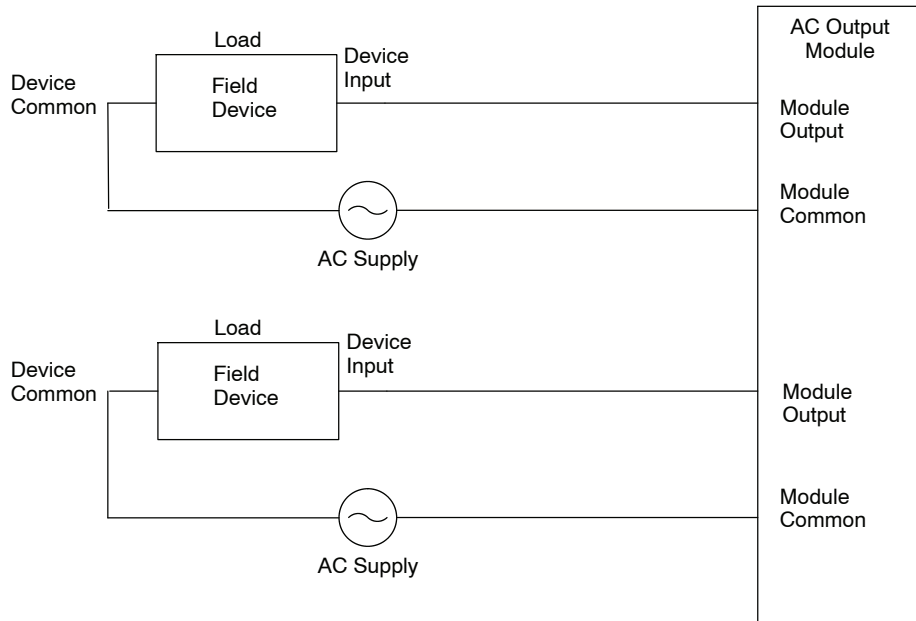

Solid State Field Device Wiring to DC Input Modules

NPN Field Device Example

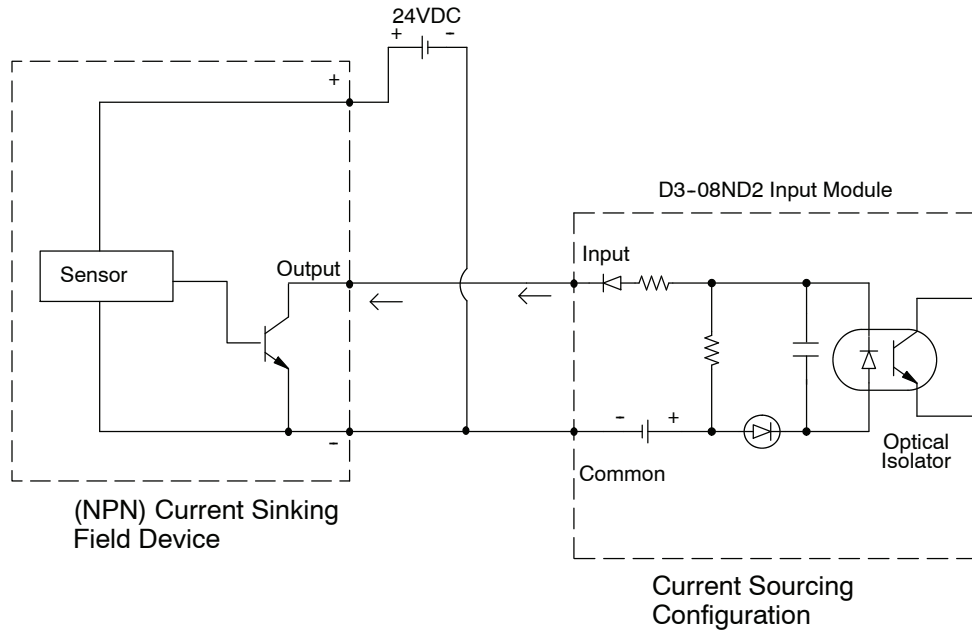

PNP Field Device Example

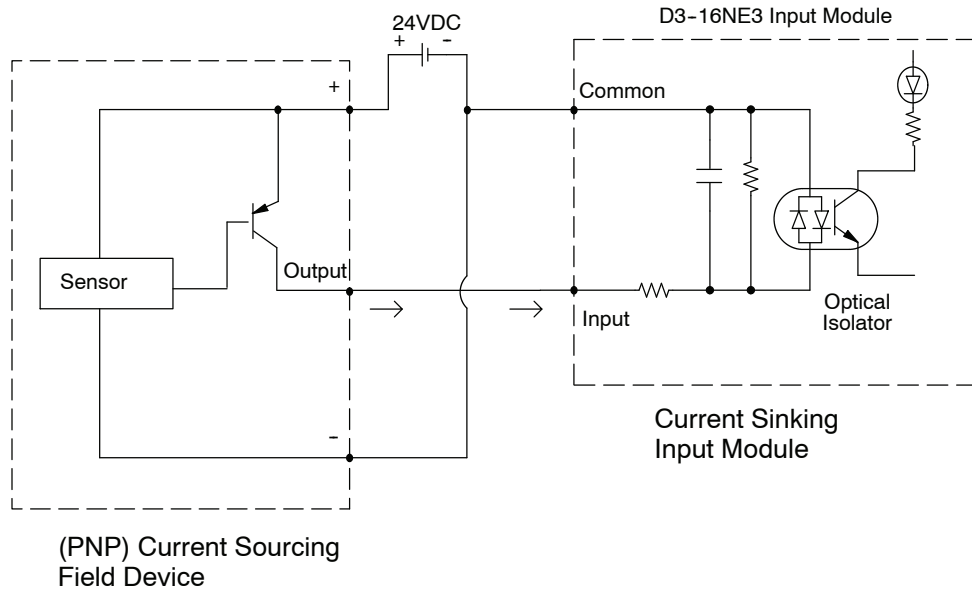

Derating Characteristics

The DL305 input and output module operating specifications change depending on ambient temperature. The I/O specifications have a derating chart for each module which shows functionality in respect to ambient temperature.

The example below shows a derating curve for a D3-08ND2 discrete input module where the operating specifications do not change within the specified temperature operating range.

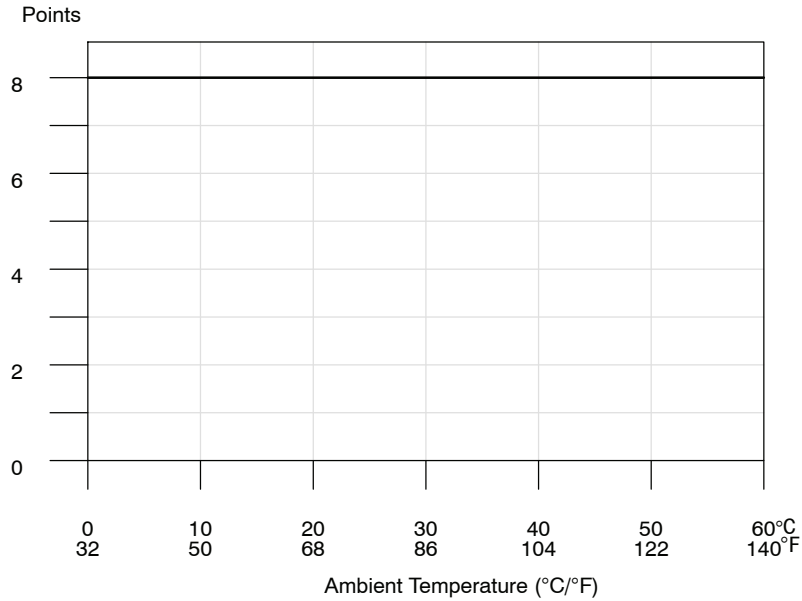

The example below shows a derating curve for a D3-16TD-1 discrete output module where the operating specifications are affected depending on ambient temperature.

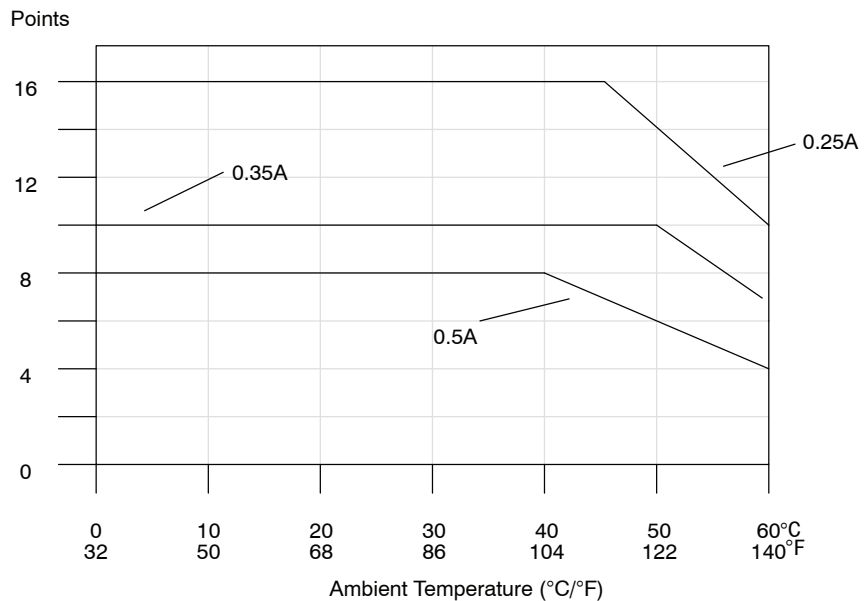

I/O Wiring Guidelines

General Considerations

The following information is to give you a general idea on how to wire the different types of modules in the DL305 system. For specific information on wiring a particular module refer to the specification sheet in the appropriate I/O chapter.

Consider the following guidelines when connecting the field wiring.

1. There is a maximum AWG the modules can accept. You can use a smaller AWG than is noted in the table below.

Module type	Maximum AWG
8 point	12
16 point	16

2. Always use a continuous length of wire, do not combine wires to attain a desired length.
3. Use the shortest possible cable length.
4. Use wire trays for routing where possible.
5. Avoid running wires near high energy wiring.
6. Avoid running input wiring in close proximity to output wiring where possible.
7. To minimize voltage drops when wires must run a long distance, consider using multiple wires for the return line.
8. Avoid running DC wiring in close proximity to AC wiring where possible.
9. Avoid creating sharp bends in the wires.

Wiring the Different Module Types

There are three main types of module faces for the DL305 I/O. These module faces are: lift covers over terminal blocks, flip covers over terminal blocks and D-shell compatible sockets. If the module you are using has a cover you can remove the cover either by lifting from the bottom or by flipping the door open. Some of the modules have removable terminal blocks. These modules can be recognized by the squeeze tabs on the top and bottom of the terminal block. To remove the terminal block, press the squeeze tabs and pull the block away from the module.

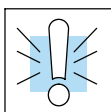

WARNING: For some modules, field device power may still be present on the terminal block even though the PLC system is turned off. To minimize the risk of electrical shock, check all field device power *before* you remove the connector.

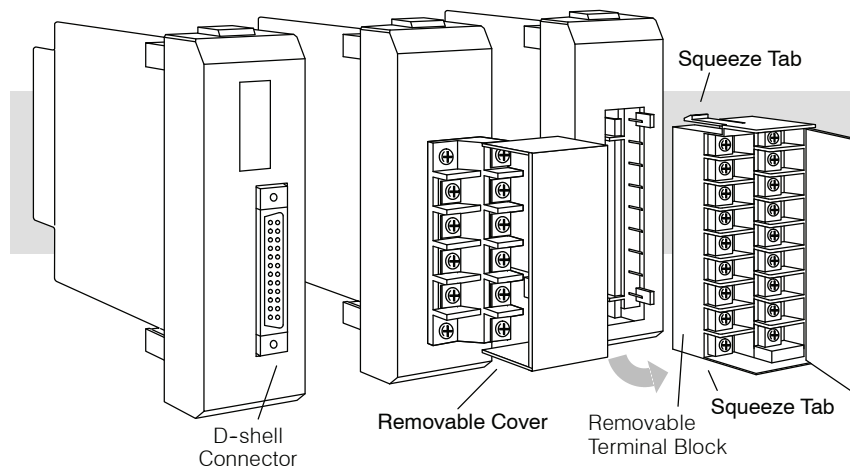

Fuse Protection

To help avoid blowing the internal module fuses, we suggest you add external fuses to your I/O wiring. A fast blow fuse with a lower current rating than the I/O module fuse can be added to each common. Or, you can add a fuse with a rating of slightly less than the maximum current per output point to each output. Refer to the I/O module specification sheets to find the maximum current per point or per common for output modules. Adding the external fuse does not guarantee the prevention of module damage, but it will provide added protection.

External Fuse Example

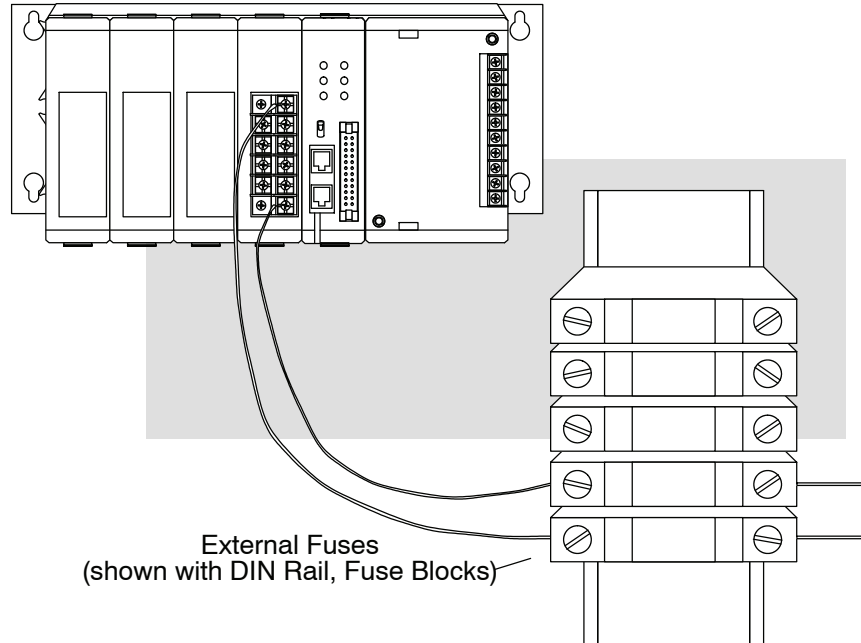

WARNING: For modules which have soldered-in or non-replaceable fuses, we recommend that you return the module to us and let us replace your blown fuse(s) since the module fuses are attached to the board and disassembling the module will void your warranty.