

Special Features

In This Chapter. . . .

- Planning a Home Search Application
- Using Sampling

Planning a Home Search Application

Requirements for Home Search

We discussed briefly in Chapter 1 some of the basics concerning the automatic home search feature of the HSC. Here we will elaborate further.

The built-in algorithm of the HSC assumes that you have specified certain types of field devices for your home search system. It also assumes they have been physically configured in a certain manner. Let's take a closer look:

- LS2 must be a negative logic switch (i.e. turn OFF when work is near).
- The status of LS1 must always be ON during Home Search. An actual physical device is not required as long as the input point (LS1) is always HIGH during Home Search. If you attach a switch to LS1, make sure it is the negative logic type also.
- LD must be a positive logic switch (i.e. turn ON when work is near).
- In relationship to the motor and its shaft rotation, the LS1 switch must be located so that when the motor turns clockwise, the moving work apparatus travels in the direction of the LS1 switch. Likewise, when the motor moves counter-clockwise, the work apparatus moves toward the LS2 switch.
- LS1 and LS2 define the two ends of the work area. The Home Search algorithm uses the status of these two input points while locating home position.
- Home position is defined to be **near** LD on the LS2 side.

Example of Home Search Application

In the diagram on the opposite page, assume that the drill head has just performed its last task on the work piece and has been raised. Your ladder logic has invoked home search (OFF to ON transition of Ym+15). The status of all your outputs are stored in memory, because when Home Search is complete the outputs will be returned to their original state. We will assume that the pitch of the lead screw is such that CCW movement is to the left toward LS2:

Step1 – CCW turns ON and moves the drill head toward LS2 at full speed.

Step2 – When LS2 detects the drill head and turns OFF, CW is turned ON (CCW OFF), and movement is back toward LD at full speed.

Step3 – When LD turns ON, OUT1 (deceleration) turns ON.

Step4 – The drill head moves slowly past LD until LD turns OFF.

Step5 – When LD has turned OFF, CCW is once again turned ON, and with OUT1 still ON, it moves slowly toward LD again. LD turns ON. Drill head continues moving until LD turns OFF.

Step6 – If you were in the UP/DOWN mode of counting, the drill head would stop as soon as LD turns OFF. Home is defined as that position. This would be the end of Home Search for the UP/DOWN mode. Read the note below for use of Ym+27 (enabling OUT2, the brake) to assure that momentum does not cause overshoot.

Step7 – If you were in the Quadrature mode of counting, the drill head would not stop when LD turns OFF. It would, continue until INZ turns ON. It would stop at this point and the Home Search would be finished. Read the note below for use of Ym+27 (enabling OUT2, the brake) to assure that momentum does not cause overshoot.

NOTE: If you want the brake (OUT2) to turn ON when Home is found, then you must turn ON Ym+27 before invoking Home Search. This feature is only supported in HSC modules with date codes 9502 (Feb. '95) or later. You will find this production date on the bar coded label located on the side of the module.

Example Home Search Setup

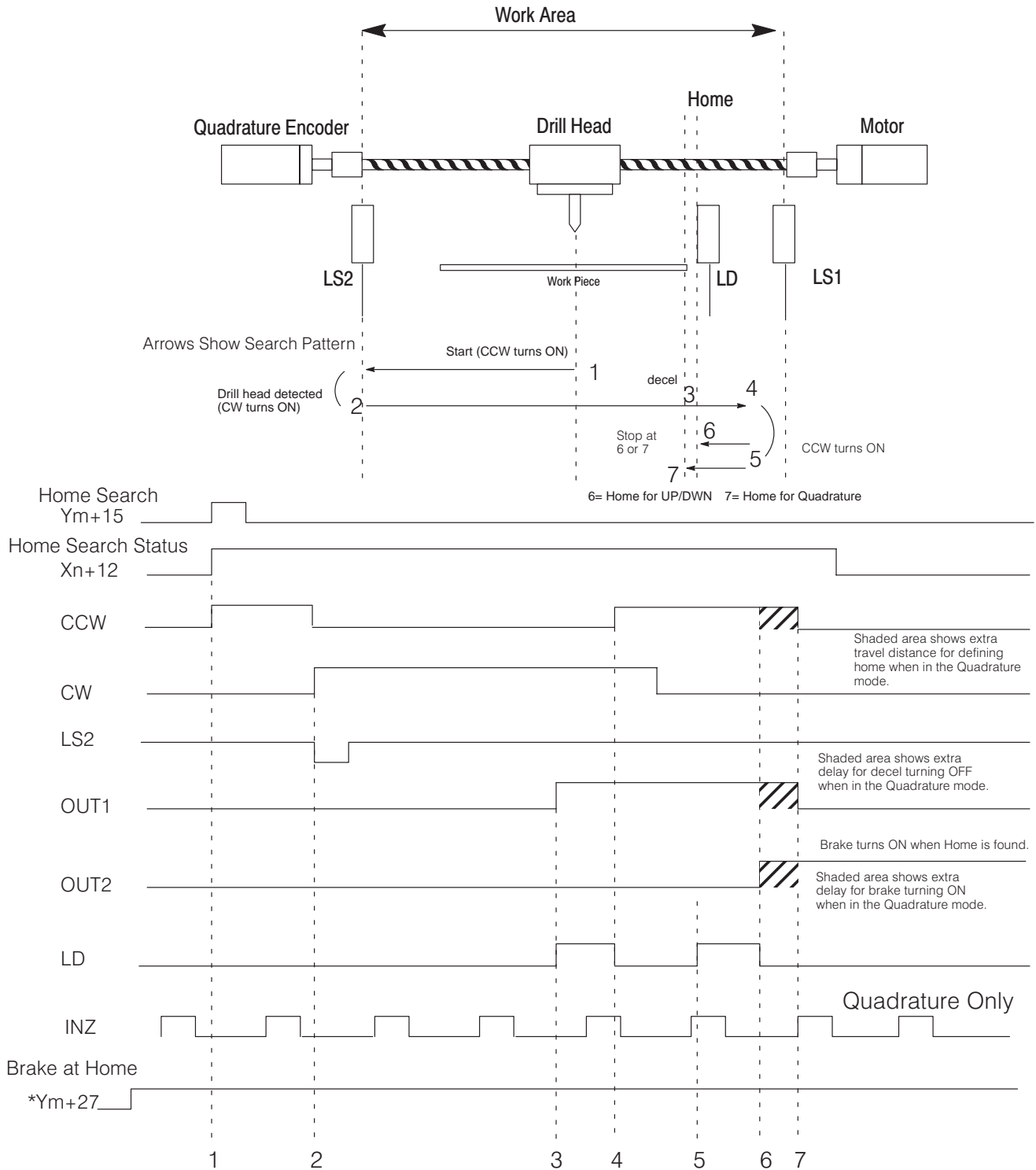

***Note:** Ym+27 only affects the status of OUT2. The rest of the Home Search algorithm operates regardless of the status of Ym+27.

Using Sampling

Why Use Sampling?

The D4-HSC allows you to determine the difference in the current count over a specified time period in the range of 3 to 29997ms. This is *sampling*. By knowing how many pulses have been counted in a specified period of time, sampling can be useful for determining flow rate, the speed of a rotating shaft, etc. Sampling uses two shared memory locations:

- Step1 – **Timebase** (length of measuring period)–Address hex 14 through 15
 Step2 – **Sampled Count** (number of pulses counted)–Address hex 16 through 19

The timebase is entered into shared memory (hex 14-15) by your ladder logic. You don't enter the actual time, such as 3-29997ms. Instead, the value actually entered is a number in the range 1 through 9999 (BCD). The HSC multiplies this number by 3ms in order to convert it to the actual timebase. That is, if your program writes a 4 there, then the sampling timebase is $4 \times 3\text{ms} = 12\text{ms}$. When executed, the counter will count for 12 ms and then the HSC will store the count for that time period into hex 16 through 19.

Enabling and Monitoring the Sampling

The act of sampling with the HSC is invoked by using $Ym+21$. $Xn+13$ will turn ON when sampling is initiated and remain ON until it is complete. The short example logic shown below illustrates how to enable the sampling feature and then use the status flag to initiate a reading of the sampled count into V-memory.

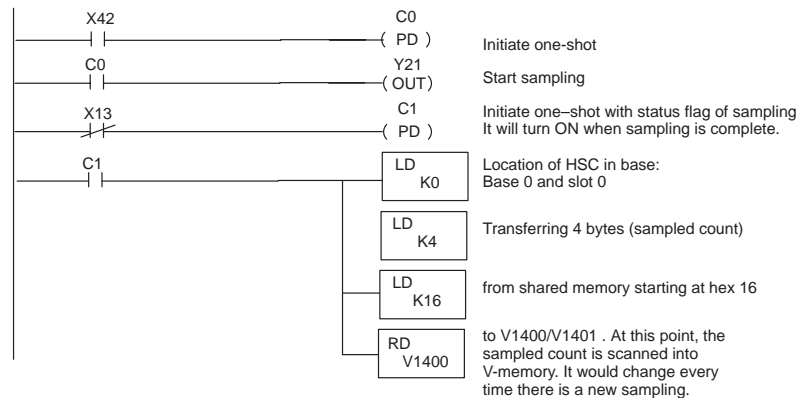

You should probably take note that $Ym+21$ does not have to stay ON. If $Ym+21$ is turned OFF, the sampling process would continue until completion anyway.

NOTE: When using sampling, be aware that any other function of the HSC that alters or inhibits the current count (i.e reset, offset, count inhibit) will affect the sampling.

How to Calculate the Timebase

As mentioned, if you want to compute the value of the number to store in shared memory for your timebase, then you will have to divide your actual timebase value by 3ms. For example, suppose you wanted a time base of 300ms. You would store 300ms/3ms in shared memory hex 14 thru 15:

$$300\text{ms} \div 3\text{ms} = 100$$

What Happens If You Want to Enter a Value with Decimal Points?

Not every timebase computation is going to come out with integer values. For example, if you want a time base of 1000ms, here is the math:

$$1000\text{ms} \div 3\text{ms} = 333.33$$

A normal question at this juncture is “How do I enter a value with ladder logic that has a decimal point?”. The answer is: You can’t. You will have to enter the nearest integer, which is 333. This means your actual time base is 999ms.

In most cases, this will not cause you any problems. You could, for example, in most cases accomplish whatever you want with the sampling even though it is missing 1ms of sampling time. However, with very high speed counting and a need to use this feature to determine frequency, you could experience difficulty. You should be aware of this when planning your application.

Summary of Input and Output Relays for Sampling

The chart below summarizes the X and Y output assignments for sampling.

X or Y No.	Function
Xn+13	Reports the status of sampling process. ON during the process. OFF when sampling is finished or not taking place.
Ym+21	Transition from OFF to ON enables the sampling process. Turning this relay OFF will not stop the sampling process. It continues to completion.