

GETTING STARTED



CHAPTER 1

Contents of this Chapter...

Manual Overview	1-2
Overview of this Publication	1-2
Who Should Read This Manual	1-2
Supplemental Publications	1-2
Technical Support	1-2
Special Symbols	1-2
GS1 AC Drive Introduction	1-3
Purpose of AC Drives	1-3
Drive Package Contents	1-3
Nameplate Information	1-3
Model Explanation	1-3
External Parts and Labels	1-4
GS1 AC Drive Specifications	1-5

Manual Overview

Overview of this Publication

The GS1 AC Drive User Manual describes the installation, configuration, and methods of operation of the GS1 Series AC Drive.

Who Should Read This Manual

This manual contains important information for those who will install, maintain, and/or operate any of the GS1 Series AC Drives.

Supplemental Publications

The National Electrical Manufacturers Association (NEMA) publishes many different documents that discuss standards for industrial control equipment. Global Engineering Documents handles the sale of NEMA documents. For more information, you can contact Global Engineering Documents at:

**15 Inverness Way East
Englewood, CO 80112-5776
1-800-854-7179 (within the U.S.)
303-397-7956 (international)
www.global.ihs.com**

NEMA documents that might assist with your AC drive systems are:

- **Application Guide for AC Adjustable Speed Drive Systems**
- **Safety Standards for Construction and Guide for Selection, Installation, and Operation of Adjustable Speed Drive Systems.**

Technical Support

By Telephone: 770-844-4200
(Mon.-Fri., 9:00 a.m.-6:00 p.m. E.T.)

On the Web: www.automationdirect.com

Our technical support group is glad to work with you in answering your questions. If you cannot find the solution to your particular application, or, if for any reason you need additional technical assistance, please call technical support at **770-844-4200**. We are available weekdays from 9:00 a.m. to 6:00 p.m. Eastern Time.

We also encourage you to visit our web site where you can find technical and non-technical information about our products and our company. Visit us at **www.automationdirect.com**.

Special Symbols



When you see the “notepad” icon in the left-hand margin, the paragraph to its immediate right will be a special note.



When you see the “exclamation mark” icon in the left-hand margin, the paragraph to its immediate right will be a WARNING. This information could prevent injury, loss of property, or even death (in extreme cases).

GS1 AC Drive Introduction

Purpose of AC Drives

AC drives are generally known by many different names: Adjustable Frequency Drives (AFD), Variable Frequency Drives (VFD), and Inverters. Drives are used primarily to vary the speed of three phase AC induction motors, and they also provide non-emergency start and stop control, acceleration and deceleration, and overload protection. By gradually accelerating the motor, drives can reduce the amount of motor startup inrush current.

AC drives function by converting incoming AC power to DC, which is then synthesized back into three phase output power. The voltage and frequency of this synthesized output power is directly varied by the drive, where the frequency determines the speed of the three phase AC induction motor.

Drive Package Contents

After receiving the AC motor drive, please check for the following:

- Make sure that the package includes an AC drive, the GS1 Series AC Drive User Manual, and the GS1 Series AC Drive Quick Reference.
- Inspect the unit to insure it was not damaged during shipment.
- Make sure that the part number indicated on the nameplate corresponds with the part number of your order.

Nameplate Information

Example of 0.5 hp 115 VAC drive

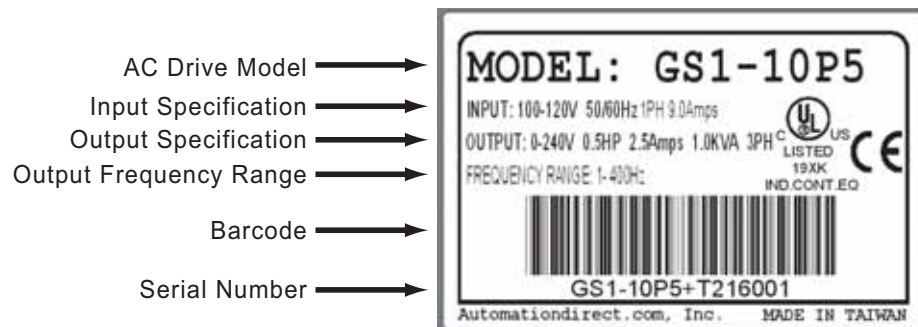

Model Explanation

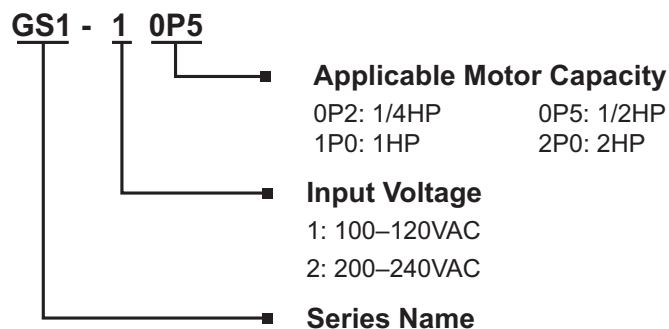

External Parts and Labels



- ① Digital Keypad
- ② Ventilation Slots
- ③ Mounting Screw Holes
- ④ Nameplate Label
- ⑤ Input Power Terminals
- ⑥ Control Input/Output Terminals
- ⑦ Output Power Terminals

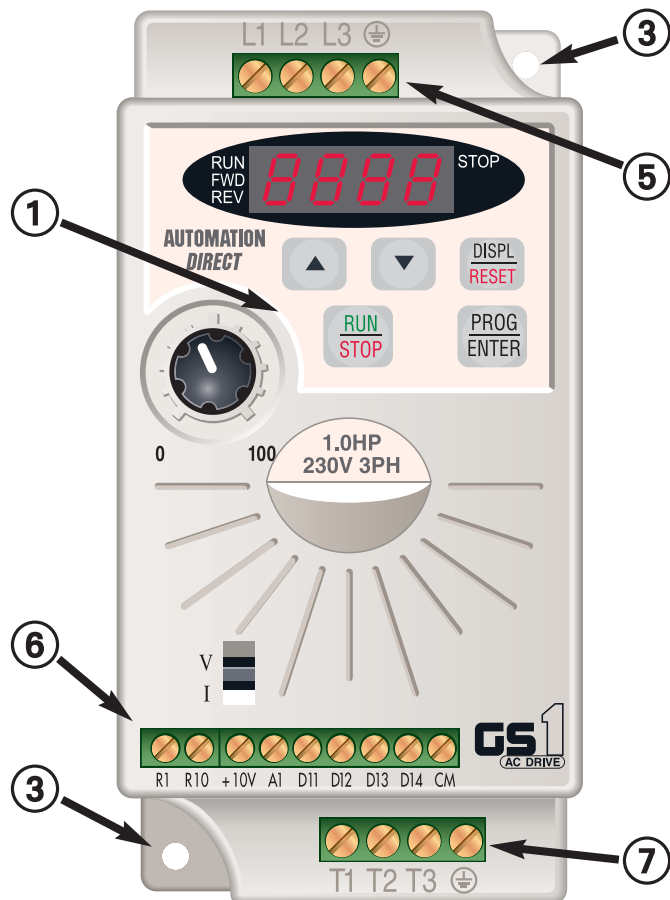

GS1 AC Drive Specifications

115V Class			
Model Name		GS1-10P2	GS1-10P5
Motor Rating	HP	1/4 hp	1/2 hp
	kW	0.2 kW	0.4 kW
Rated Input Voltage	Single-phase: 100–120 VAC $\pm 10\%$, 50/60 Hz, $\pm 5\%$		
Maximum Output Voltage	Three-phase: 200–240 VAC (x2 of input voltage)		
Rated Input Current (A)	6		9
Rated Output Current (A)	1.6		2.5
Short Circuit Withstand (A, rms symmetrical)	5kA @ 120 VAC		
Watt Loss 100% I (W)	19.2		19.2
Weight (lb)	2.16		2.24
Dimensions (HxWxD)	132.0 mm [5.20 in] x 68.0 mm [2.68 in] x 128.1 mm [5.04 in]		

230V Class					
Model Name		GS1-20P2	GS1-20P5	GS1-21P0	GS1-22P0
Motor Rating	HP	1/4 hp	1/2 hp	1 hp	2 hp
	kW	0.2 kW	0.4 kW	0.7 kW	1.5 kW
Rated Input Voltage	Single/three-phase: 200–240 VAC $\pm 10\%$, 50/60 Hz $\pm 5\%$			Three-phase: 200–240VAC $\pm 10\%$, 50/60Hz $\pm 5\%$	
Maximum Output Voltage	Three-phase: 200–240VAC (proportional to input voltage)				
Rated Input Current (A)	4.9/1.9	6.5/2.7	9.7/5.1	9	
Rated Output Current (A)	1.6	2.5	4.2	7.0	
Short Circuit Withstand (A, rms symmetrical)	5kA @ 240 VAC				
Watt Loss 100% I (W)	18.4	26.8	44.6	73	
Weight (lb)	2.06	2.2	2.26	2.2	
Dimensions (HxWxD)	132.0 mm [5.20 in] x 68.0 mm [2.68 in] x 128.1 mm [5.04 in]				

General Specifications			
Control Characteristics			
Control System		Sinusoidal Pulse Width Modulation, carrier frequency 3–10 kHz	
Rated Output Frequency		1.0 to 400.0 Hz	
Output Frequency Resolution		0.1 Hz	
Overload Capacity		150% of rated current for 1 minute	
Torque Characteristics		Includes auto-slip compensation and starting torque 150% @ 5.0 Hz	
DC Braking		Operation frequency: 0 to 60 Hz, 0–30% rated voltage. Start time 0.0–5.0 seconds. Stop time 0.0–25.0 seconds	
Acceleration/Deceleration Time		0.1 to 600 seconds (can be set individually)	
Voltage/Frequency Pattern		V/F pattern adjustable. Settings available for Constant Torque - low and high starting torque, Variable Torque - low and high starting torque, and user configured	
Stall Prevention Level		20 to 200% or rated current	
Operation Specifications			
Inputs	Frequency Setting	Keypad	Setting by <UP> or <DOWN> buttons or potentiometer
		External Signal	Potentiometer - 3 to 5k Ω , 0.5W; 0 to 10 VDC (input impedance 10 k Ω); 0 to 20 mA / 4 to 20 mA (input impedance 250 Ω); Multi-function inputs 3 and 4 (3 steps, JOG, UP/DOWN command); RS-485 communication setting
	Operation Setting	Keypad	Setting by <RUN>, <STOP> buttons
		External Signal	DI1, DI2, DI3, DI4 can be combined to offer various modes of operation, RS-485 communication port
	Input Terminals	Digital	4 user-programmable: FWD/STOP, REV/STOP, RUN/STOP, REV/FWD, RUN momentary (N.O.), STOP momentary (N.C.), External Fault (N.O./N.C.), External Reset, Multi-Speed Bit (1 and 2), Jog, External Base Block (N.O./N.C.), Second Accel/Decel Time, Speed Hold, Increase Speed, Decrease Speed, Reset Speed to Zero, Input Disable
		Analog	1 user-configurable, 10 bit resolution 0 to 10 VAC, (input impedance 10 k Ω), 0 to 20 mA, (input impedance 250 Ω) 4 to 20 mA, (input impedance 250 Ω)
Outputs	Output Terminals	Digital	1 user programmable: AC drive Running, AC drive Fault, At Speed, Zero Speed, Above Desired Frequency (P 3-16), Below Desired Frequency (P 3-16), At Maximum Speed, Over-torque Detected, Above Desired Current (P3-17), Below Desired Current (P 3-17)
	Operating Functions		Automatic voltage regulation, S-curve, Over-voltage stall prevention, DC braking, Fault records, Adjustable carried frequency, Starting frequency setting of DC braking, Over-current stall prevention, Momentary power loss restart, Reverse inhibition, Frequency limits, Parameter lock/reset

General Specifications (continued)		
Protective Functions		Overcurrent, Overvoltage, Undervoltage, Electronic thermal motor overload, Overheating, Overload, Self testing
Operator Interface	Operator Devices	5-key, 4-digit, 7-segment LED, 4 status LEDs, potentiometer
	Programming	Parameter values for setup and review, fault codes
	Status Display	Master Frequency, Output Frequency, Scaled Output Frequency, Output Voltage, DC Bus Voltage, Output Direction, Trip Event Monitor, Trip History Monitor
	Key Functions	RUN/STOP, DISPLAY/RESET, PROGRAM/ENTER, <UP>, <DOWN>
Environment	Enclosure Rating	Protected chassis, IP20
	Ambient Temperature	-10° to 40°C (14°F to 104°F) w/o derating
	Ambient Humidity	0 to 90% RH (non-condensing)
	Vibration	9.8 m/s ² (1G), less than 10 Hz; 5.88 m/s ² (0.6G) 20 to 50 Hz
	Installation Location	Altitude 1000m or lower above sea level, keep from corrosive gas, liquid and dust

**BLANK
PAGE**