

# INSTALLATION AND FIELD WIRING

---



## In This Chapter...

Installing the H0-CTRIO Module .....	2-2
Setting the H0-CTRIO Jumpers .....	2-3
Wiring the H0-CTRIO Module .....	2-4
H0-CTRIO Quadrature Encoder Wiring Example .....	2-5
H0-CTRIO TTL Quadrature Encoder Wiring Example .....	2-6
H0-CTRIO TTL Input Wiring Example .....	2-7
H0-CTRIO Output Wiring Schematic .....	2-8
H0-CTRIO Stepper Drive Wiring Example .....	2-9
Installing the H2-CTRIO Module .....	2-10
Setting the H2-CTRIO Jumpers .....	2-11
Wiring the H2-CTRIO Module .....	2-12
H2-CTRIO Quadrature Encoder Wiring Example .....	2-13
H2-CTRIO TTL Quadrature Encoder Wiring Example .....	2-14
H2-CTRIO TTL Input Wiring Example .....	2-15
H2-CTRIO Output Wiring Schematic .....	2-16
H2-CTRIO Stepper Drive Wiring Example .....	2-17
Installing the H4-CTRIO Module .....	2-18
Wiring the H4-CTRIO Module .....	2-19
H4-CTRIO Quadrature Encoder Wiring Example .....	2-20
H4-CTRIO TTL Quadrature Encoder Wiring Example .....	2-21
H4-CTRIO TTL Input Wiring Example .....	2-22
H4-CTRIO Output Wiring Schematic .....	2-23
H4-CTRIO Stepper Drive Wiring Example .....	2-24
Installing the T1H-CTRIO Module .....	2-25
Wiring the T1H-CTRIO Module .....	2-26
T1H-CTRIO Quadrature Encoder Wiring Example .....	2-28
T1H-CTRIO TTL Quadrature Encoder Wiring Example .....	2-29
T1H-CTRIO TTL Input Wiring Example .....	2-30
T1H-CTRIO Output Wiring Schematic .....	2-31
T1H-CTRIO Stepper Drive Wiring Example .....	2-32
Solid State Input Device Wiring to H0/H2/H4/T1H-CTRIO .....	2-33

### Installing the H0-CTRIO Module

The H0-CTRIO module is compatible with *DirectLogic* DL05 and DL06 PLCs. Consideration must be given to the firmware versions of the PLCs to assure their compatibility with the H0-CTRIO. (see chart below).

The H0-CTRIO module plugs into any option card slot of any DL05 and DL06 PLC.

For installation instructions, refer to the:

- DL05 or DL06 User Manual (D0-USER-M or D0-06USER-M)

The first time you power-up the CTRIO module, you should see the OK LED blinking. The blinking LED indicates that the module is in program mode.

#### CPU and CTRIO Compatibility Chart

PLC CPU	Firmware	<i>DirectSOFT32</i>
DL05	v. 4.60 or later	v. 4.0, Build 16 or later
DL06	v. 1.40 or later	v. 4.0, Build 16 or later

Updated firmware versions can be downloaded from our web site at [www.automationdirect.com](http://www.automationdirect.com)

## Setting H0-CTRIO Jumpers

The module's internal jumpers must be set to the High Side Common position for high side switching (sourcing) outputs or to the Low Side Common position for low side switching (sinking) outputs. The sink/source jumper selection sets both outputs to the same option. Source operation is the factory default setting.

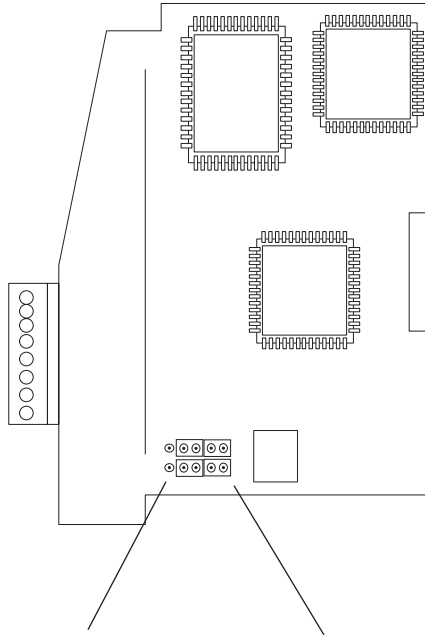

### Jumper Selections

#### Sourcing Outputs

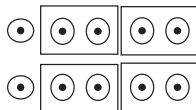

High Common position for switching the high side of a DC load.

#### Sinking Outputs

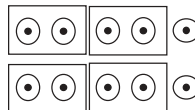

Low Common position for switching the low side of a DC load.

## Wiring the H0-CTRIO Module

The H0-CTRIO module has one input channel, consisting of 4 optically isolated input points (pts. A-D on common M). The inputs can be wired to either sink or source current. The module has 2 optically isolated output points (pts. Y0-Y1 on common YC). The outputs can be wired to either sink or source current, but the sink/source jumper selection sets both outputs to the same option. Sourcing outputs must be wired so positive current flows into the YC terminal and then out of the Yn terminal. Sinking outputs must be wired so positive current flows into Yn terminal and then out of the YC terminal (see the diagram to the right and the schematic on page 2-8).

Source operation is the factory default setting for the outputs.

The module is configured, using CTRIO Workbench, to accommodate the user's application. The function of each input (counting, timing, reset, etc.) and output (pulse output, discrete output, etc.) is defined in the configuration of the module.

Refer to Chapters 4 and 5 to determine what input and output configurations are possible.



*Field device wiring must be compatible with the module configuration.*

See the notes below for further details about power source considerations, circuit polarities, and field devices. Also, refer to the specifications on pages 1-5 and 1-6 for more information.

### Notes:

1. **Inputs (A, B, C, and D) require user-provided 9-30VDC power sources. Terminal M is the commons for the inputs. Maximum current consumption is 12mA per input point.**
2. **Polarity of the input power sources (shown above) can be reversed. Consideration must be given, however, to the polarity of the field device. Many field devices are designed for only one polarity and can be damaged if power wiring is reversed.**
3. **The maximum allowable current per output circuit is 1A.**

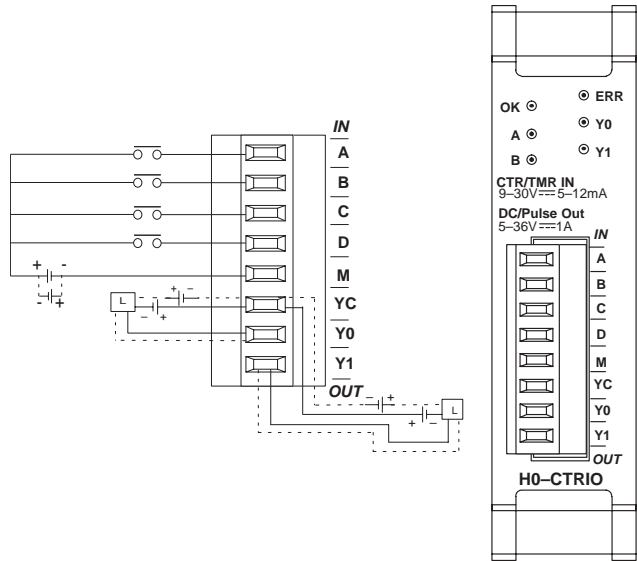

# H0- CTRIO Quadrature Encoder Wiring Example

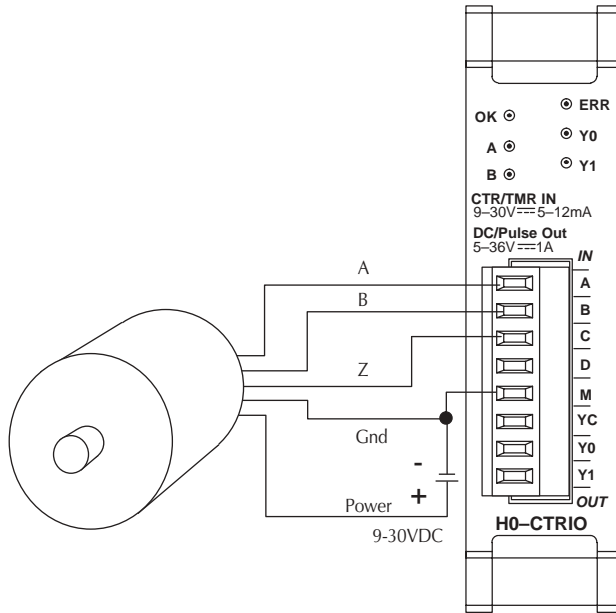

# H0-CTRIO TTL Quadrature Encoder Field Wiring

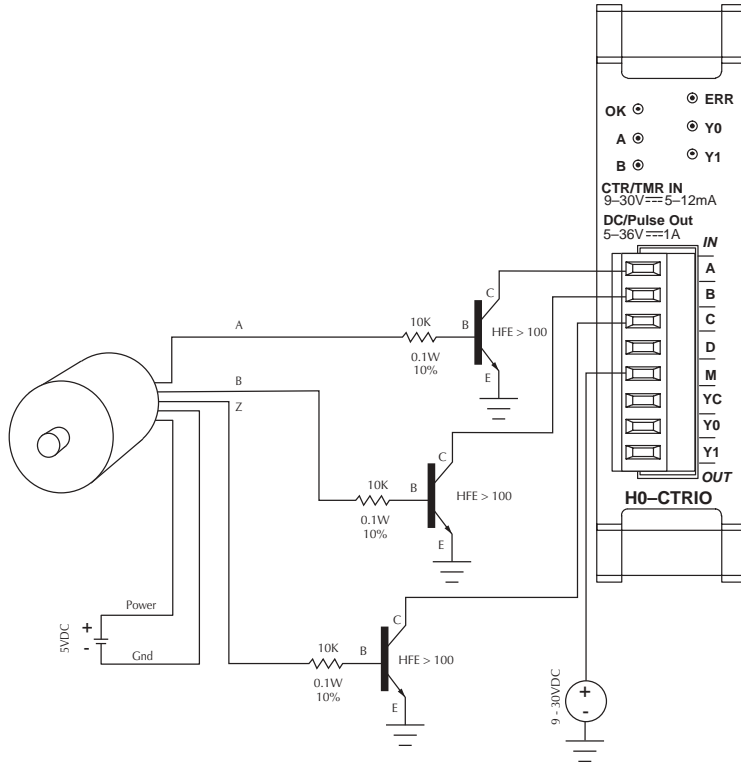

# H0-CTRIO TTL Input Wiring

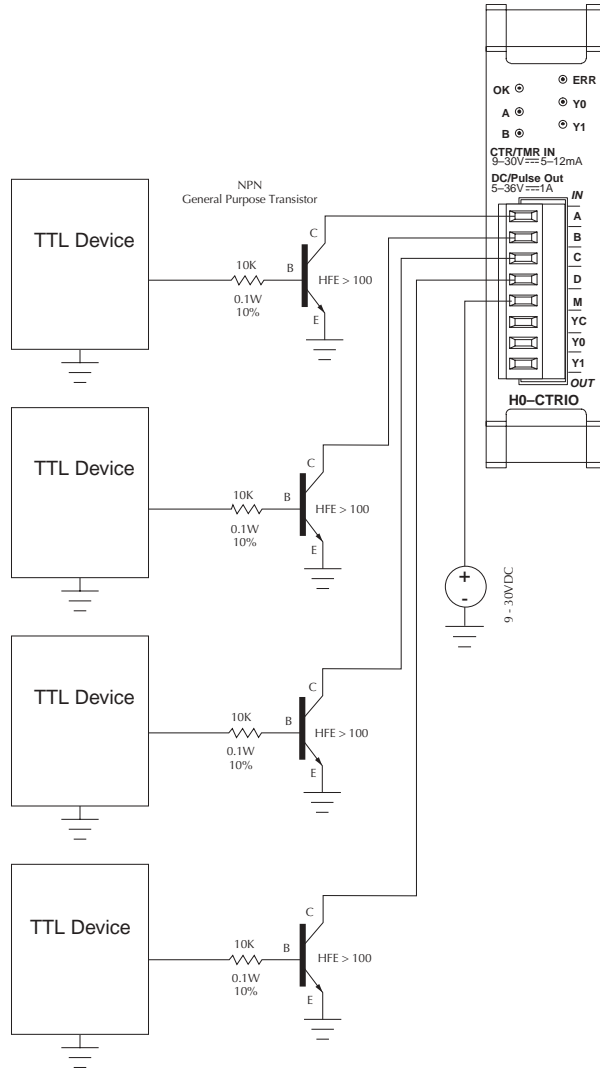

# H0- CTRIO Output Wiring Schematic

See page 2-3 for locating and setting the jumpers

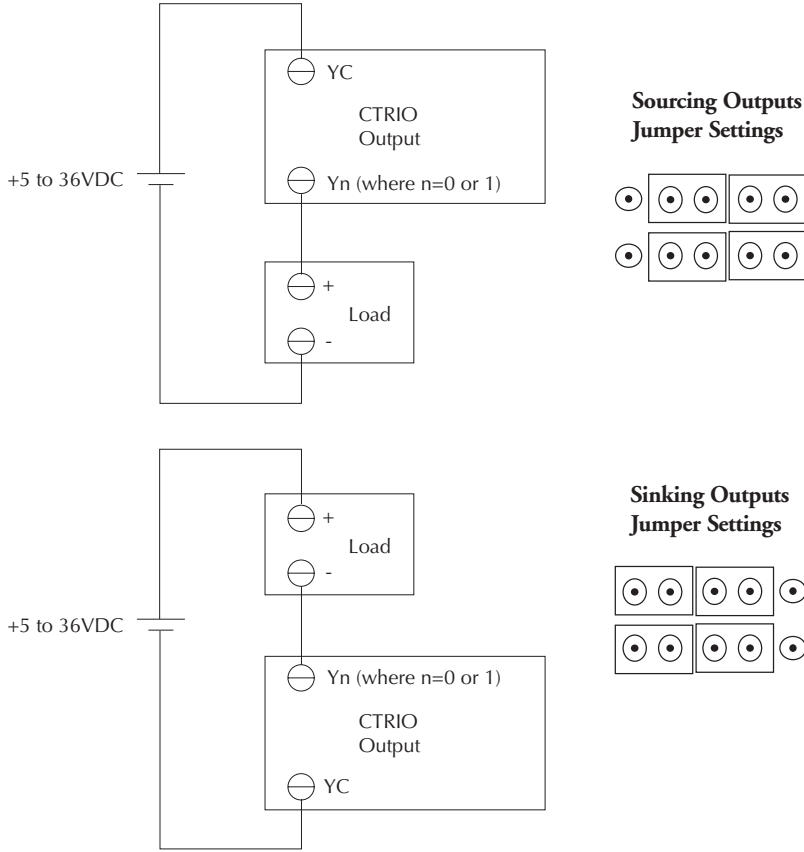

# H0-CTRIO Stepper/Servo Drive Wiring Example

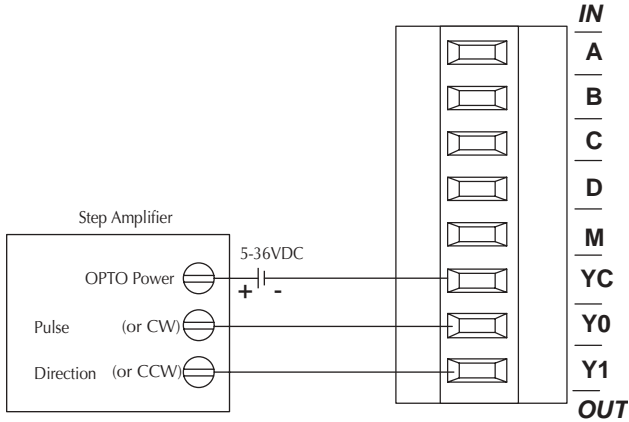

## Sinking Outputs Jumper Settings

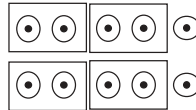

See page 2-3 for locating and setting the jumpers

# Installing the H2-CTRIO Module

The H2-CTRIO module is compatible with several DL205 CPU-slot interface devices. Consideration must be given to the firmware versions of the CPU-slot interfaces to assure their compatibility with the H2-CTRIO. (see chart below).

The H2-CTRIO module plugs into any I/O slot of any *DirectLogic* 205 base except slot 0 when using a *DirectLogic* PLC or H2-PBC controller. Slot 0 is available for the H2-CTRIO module when using the WinPLC or H2-EBC interface devices. (Slot 0 is the I/O slot adjacent to the CPU). The H2-CTRIO cannot be used in DL205 local expansion bases or in Serial Remote I/O bases.

For installation instructions, refer to the:

- DL205 User Manual (D2-USER-M) if using a *DirectLogic* PLC
- DL205 Installation and I/O Manual (D2-INST-M) if using a WinPLC, EBC, Profibus slave interface module

The first time you power-up the CTRIO module, you should see the OK LED blinking. The blinking LED indicates that the module is in program mode.

### CPU and CTRIO Compatibility Chart

CPU-slot Device	Firmware	Hardware	<i>DirectSOFT32</i>	Slot Restrictions
D2-240	v. 3.22 or later	-	v. 3.0C, Build 71 or later	any I/O slot except 0
D2-250	v. 1.56 or later	-	v. 3.0C, Build 71 or later	any I/O slot except 0
D2-250-1	v. 3.5 or later	-	v. 3.0C, Build 71 or later	any I/O slot except 0
D2-260	v. 1.2 or later	-	v. 4.0 or later	any I/O slot except 0
H2-WinPLC	-	xK or later	-	any I/O slot
H2-EBC	v. 2.1.357 or later	-	-	prior to Rev 9A any I/O slot except 0; Rev 9A or later any I/O slot
H2-PBC	-	-	-	prior to Rev 4A any I/O slot except 0; Rev 4A or later any I/O slot

Updated firmware versions can be downloaded from our web site at [www.automationdirect.com](http://www.automationdirect.com)

**Note:** for applications requiring multiple CTRIO modules, *DirectLOGIC* CPUs, and dynamic access (in ladder logic) to CTRIO data, we recommend using the D2-250-1 or D2-260 CPU. These CPUs support Bit-of-Word addressing, 32 bit math instructions and have adequate memory for multiple CTRIO applications.

## Setting H2-CTRIO Jumpers

Jumpers are provided to connect input commons or outputs/output commons. Use of these jumpers is not necessary to set up the CTRIO module. The jumpers are provided solely for convenience in wiring.

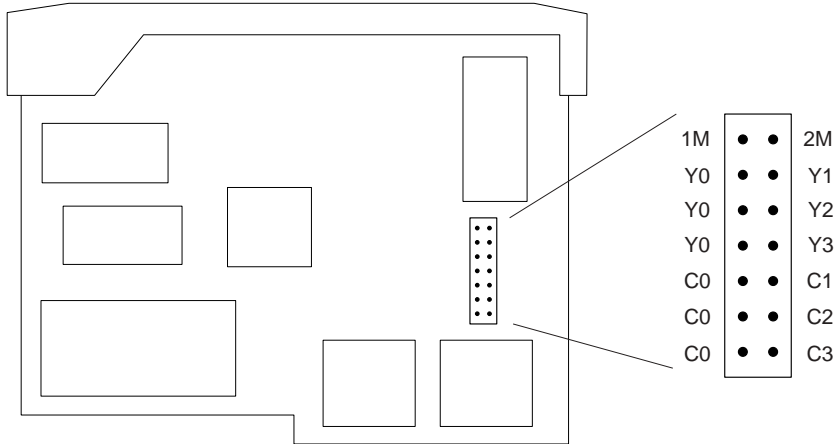

Jumper Settings	
<b>1M to 2M</b>	Share input commons between Ch 1 & Ch 2 Example: for High Side (sourcing) outputs on Y0-Y3, use the C0 to C1, C0 to C2, and C0 to C3 jumpers. Wire 5-36VDC to any of the C terminals. Example: for Low Side (sinking) outputs on C0-C3, use the Y0 to Y1, Y0 to Y2 and Y0 to Y3 jumpers. Wire 0VDC (GND) to any one of the Y terminals.
<b>Y0 to Y1, Y2, Y3</b>	Share commons between high or low side of outputs when isolation is not required
<b>C0 to C1, C2, C3</b>	

## Wiring the H2-CTRIO Module

The H2-CTRIO module has two independent input channels, each consisting of 4 optically isolated input points (pts. 1A-1D on common 1M and pts. 2A-2D on common 2M). The inputs can be wired to either sink or source current.

The module has 4 optically isolated output points (pts. Y0-Y3 with isolated commons C0-C3, respectively). The outputs must be wired so positive current flows into Cn terminal and then out of the Yn terminal (see the diagram below and the schematic on page 2–16).

Remember that the internal jumpers can be used to connect the input commons or outputs/output commons together.

The module is configured, using CTRIO Workbench, to accommodate the user's application. The function of each input (counting, timing, reset, etc.) and output (pulse output, discrete output, etc.) is defined in the configuration of the module.

Refer to Chapters 4 and 5 to determine what input and output configurations are possible.

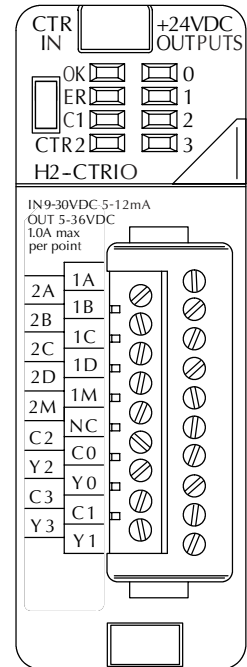
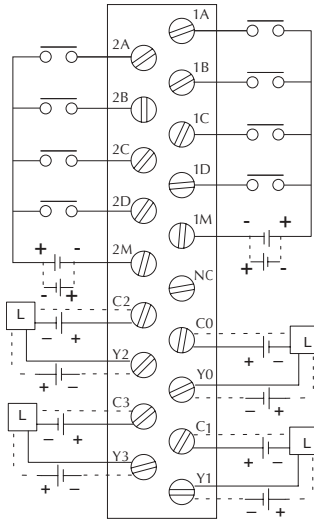

*Field device wiring must be compatible with the module configuration.*

See the notes below for further details about power source considerations, circuit polarities, and field devices. Also, refer to the specifications on pages 1-5 and 1-6 for more information.

### Notes:

1. **Inputs (1A, 1B, 1C, 1D and 2A, 2B, 2C, 2D) require user-provided 9-30VDC power sources. Terminals 1M and 2M are the commons for Channel 1 and Channel 2 inputs. Maximum current consumption is 12mA per input point.**
2. **Polarity of the input power sources (shown above) can be reversed. Consideration must be given, however, to the polarity of the field device. Many field devices are designed for only one polarity and can be damaged if power wiring is reversed.**
3. **Outputs have one polarity only (as shown above) and are powered by user-provided 5-36VDC power sources. The maximum allowable current per output circuit is 1A.**

## H2- CTRIO Quadrature Encoder Wiring Example

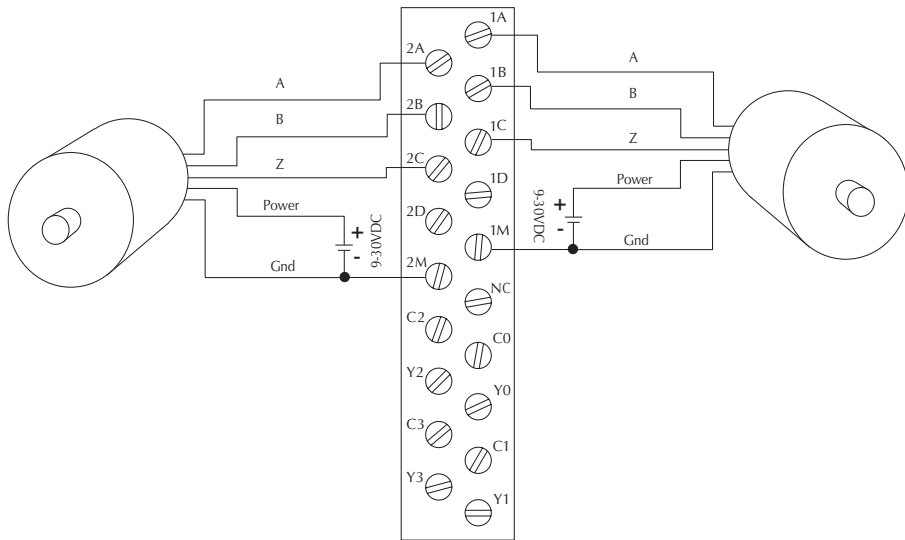

## H2-CTRIO TTL Quadrature Encoder Field Wiring

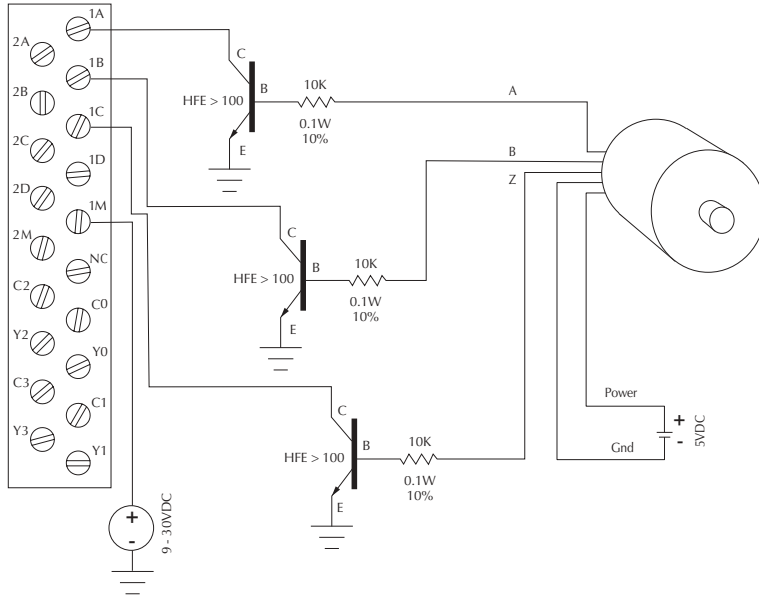

# H2-CTRIO TTL Input Wiring

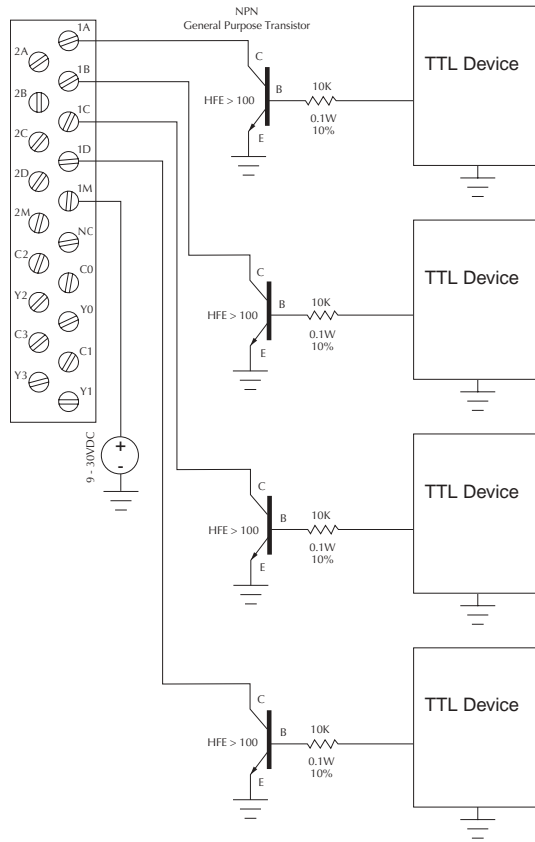

## H2- CTRIO Output Wiring Schematic

The CTRIO outputs are individually isolated DC switches that can be used to break the high or the low side of a DC load.

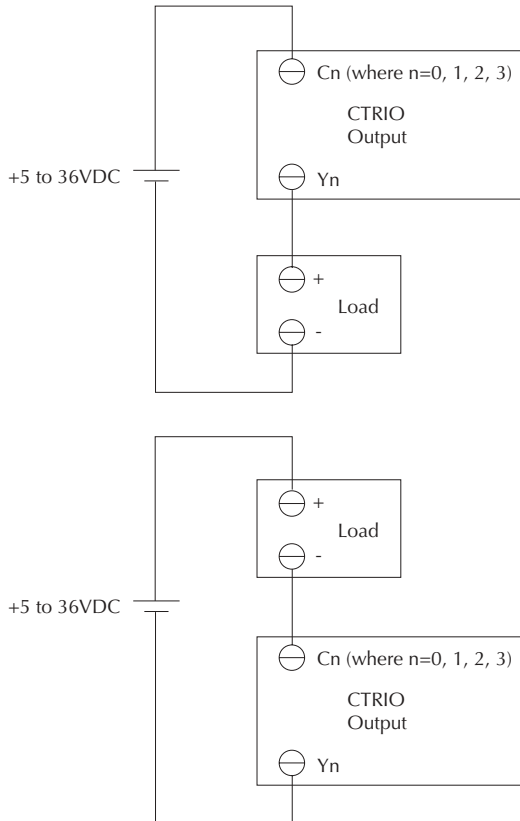

## H2-CTRIO Stepper/Servo Drive Wiring Example

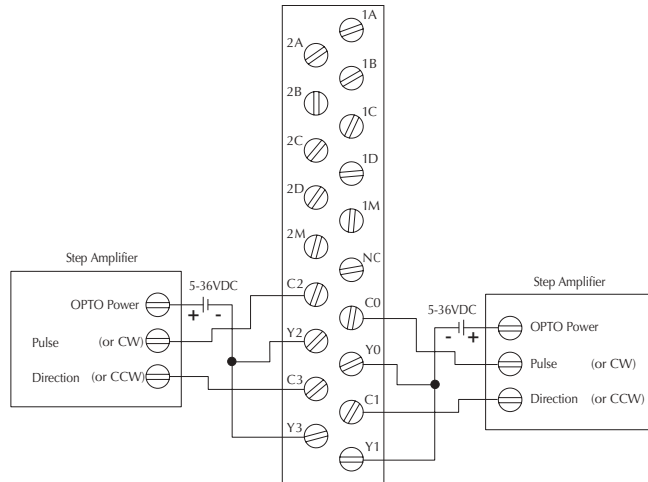

This example assumes that the Step Amplifier interface to be optocoupler LEDs (common anodes at the “OPTO Power” terminal) with internal current limiting resistors. This is a standard method, but you must consult your step amplifier documentation to ensure that this method is applicable.

# Installing the H4-CTRIO

The H4-CTRIO module is compatible with two DL405 CPU-slot interface devices. Consideration must be given to the firmware versions of the CPU-slot interfaces to assure their compatibility with the H4-CTRIO. (see chart below).

The H4-CTRIO module plugs into any I/O slot of any *DirectLogic* 405 base. H4-EBCs support the use of the H4-CTRIO in DL405 local expansion bases. The H4-CTRIO cannot be used in Serial Remote I/O bases.

For installation instructions, refer to the:

- DL405 User Manual (D4-USER-M) if using a *DirectLogic* PLC
- DL405 Installation and I/O Manual (D4-INST-M) if using an H4-EBC interface

The first time you power-up the CTRIO module, you should see the OK LED blinking. The blinking LED indicates that the module is in program mode.

### CPU and CTRIO Compatibility Chart

CPU-slot Device	Firmware	Hardware	<i>DirectSOFT32</i>
D4-450	April 2000 or earlier: H8 (CISC) v. 2.00 SH (RISC) v. 1.500 May 2000 or later: H8 (CISC) v. 2.00 SH (RISC) v. 2.500	-	v. 4.0, Build 16 or later
H4-EBC	2.1.328 or later	v. 4F or later	-

Updated firmware versions can be downloaded from our web site at [www.automationdirect.com](http://www.automationdirect.com)

## Wiring the H4-CTRIO Module

The H4-CTRIO module has two independent input channels, each consisting of 4 optically isolated input points (pts. 1A-1D on common 1M and pts. 2A-2D on common 2M). The inputs can be wired to either sink or source current.

The module has 4 optically isolated output points (pts. Y0-Y3 on isolated commons C0-C3, respectively). The outputs must be wired so that positive current flows into Cn terminal and then out of the Yn terminal (see the diagram below and the schematic on page 2-23).

The module is configured, using CTRIO Workbench, to accommodate the user's application. The function of each input (counting, timing, reset, etc.) and output (pulse output, discrete output, etc.) is defined in the configuration of the module.

Refer to Chapters 4 and 5 to determine what input and output configurations are possible.



*Field device wiring must be compatible with the module configuration.*

See the notes below for further details about power source considerations, circuit polarities, and field devices. Also, refer to the specifications on pages 1-5 and 1-6 for more information.

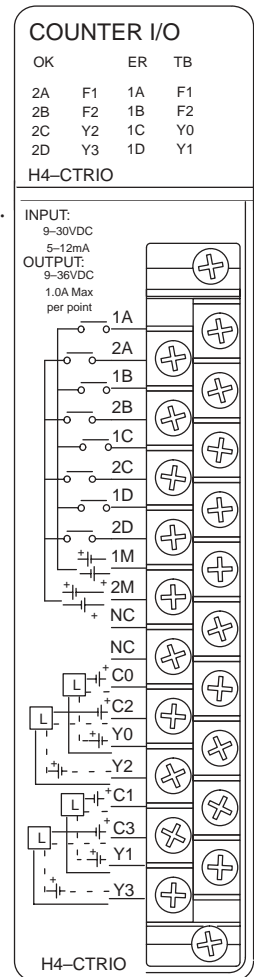
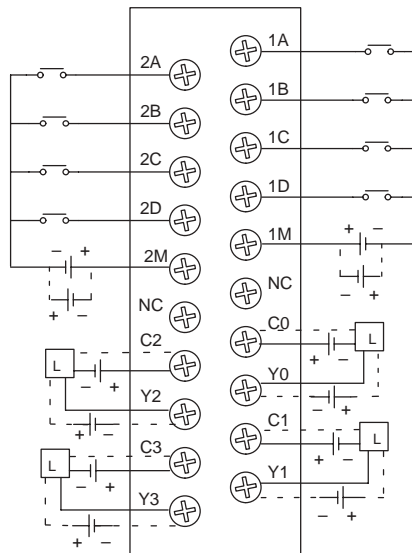

### Notes:

1. Inputs (1A, 1B, 1C, 1D and 2A, 2B, 2C, 2D) require user-provided 9-30VDC power sources. Terminals 1M and 2M are the commons for Channel 1 and Channel 2 inputs. Maximum current consumption is 12mA per input point.
2. Polarity of the input power sources (shown above) can be reversed. Consideration must be given, however, to the polarity of the field device. Many field devices are designed for only one polarity and can be damaged if power wiring is reversed.
3. Outputs have one polarity only (as shown above) and are powered by user-provided 5-36VDC power sources. The maximum allowable current per output circuit is 1A.

## H4-CTRIO Quadrature Encoder Wiring Example

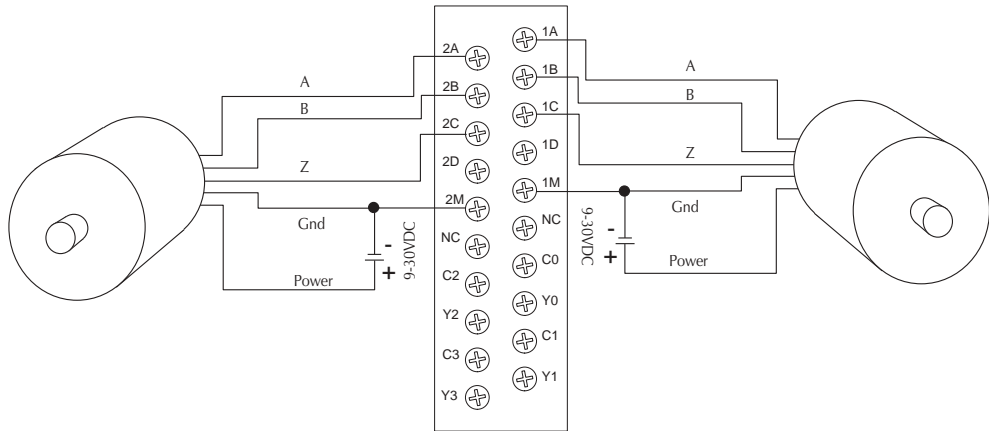

# H4-CTRIO TTL Quadrature Encoder Field Wiring

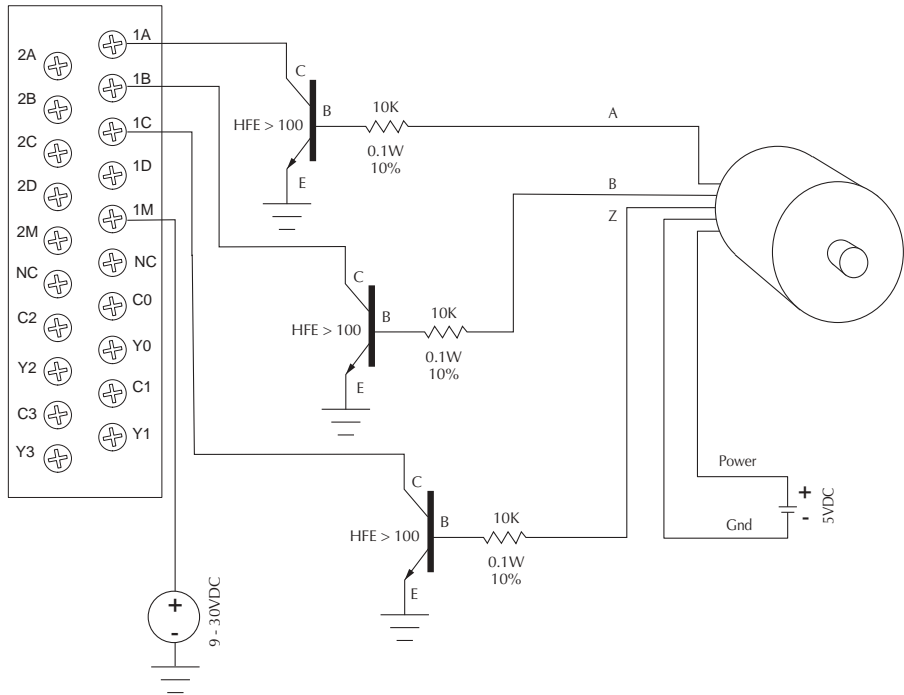

# H4-CTRIO TTL Input Wiring

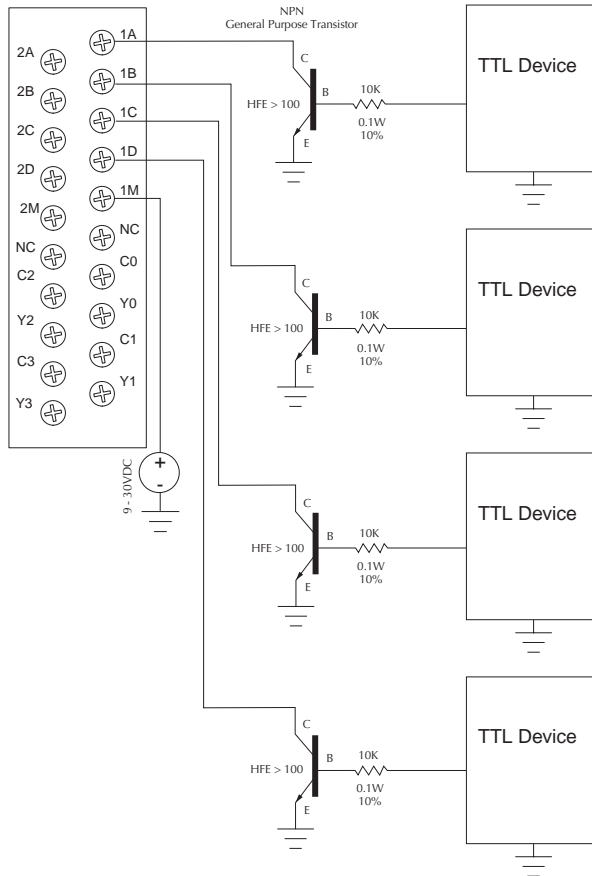

## H4-CTRIO Output Wiring Schematic

The CTRIO outputs are individually isolated DC switches that can be used to break the high or the low side of a DC load.

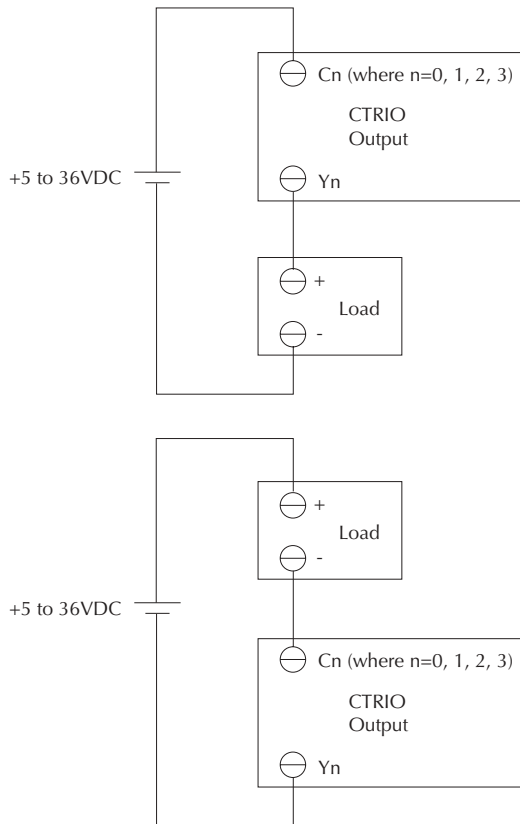

## H4-CTRIO Stepper/Servo Drive Wiring Example

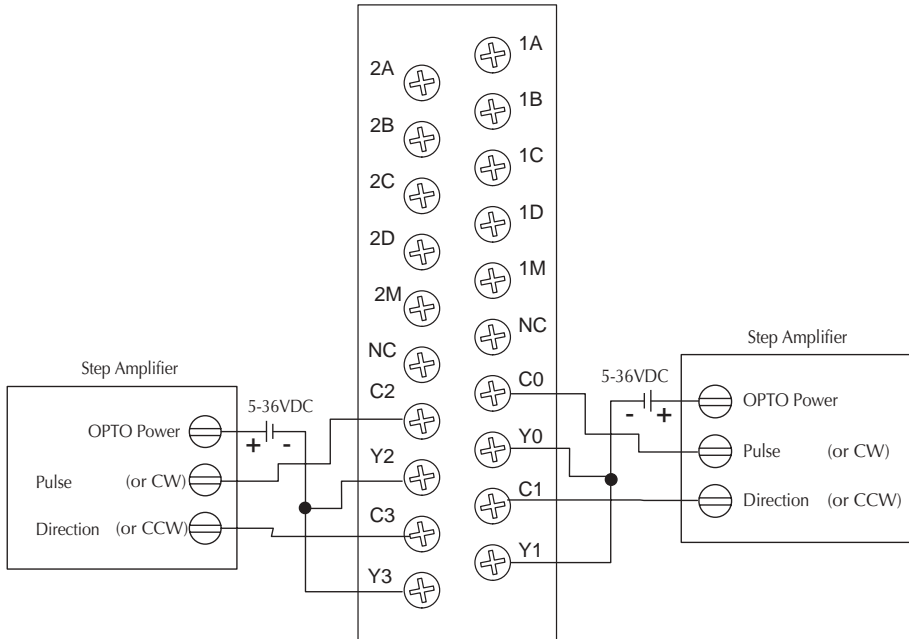

This example assumes that the Step Amplifier interface to be optocoupler LEDs (common anodes at the “OPTO Power” terminal) with internal current limiting resistors. This is a standard method, but you must consult you step amplifier documentation to ensure that this method is applicable.

## Installing the T1H-CTRIO

The T1H-CTRIO module is compatible with several Terminator I/O Network interface devices. Consideration must be given to the firmware versions of the Network interfaces to assure their compatibility with the T1H-CTRIO. (see chart below).

The T1H-CTRIO module plugs into any valid I/O slot in a Terminator I/O system. The T1H-CTRIO cannot be used in Serial Remote I/O bases (T1K-RSSS).

For installation instructions, refer to the:

- Terminator I/O Installation and I/O Manual (T1K-INST-M)

The first time you power-up the CTRIO module, you should see the OK LED blinking. The blinking LED indicates that the module is in program mode.

### CPU and CTRIO Compatibility Chart

CPU-slot Device*	Firmware	Hardware
T1H-EBC	v. 1.0.444 or later	v. 2I or later
T1H-PBC	v. 1.1.10 or later	v. 2D or later
T1K-DEVNETS	v. 1.80 or later	-
T1K-MODBUS	v. 1.80 or later	-

Updated firmware versions can be downloaded from our web site at [www.automationdirect.com](http://www.automationdirect.com)

## Wiring the T1H-CTRIO Module

The T1H-CTRIO module has two independent input channels, each consisting of 4 optically isolated input points (pts. 1A-1D on common 1M and pts. 2A-2D on common 2M). The inputs can be wired to either sink or source current.

The module has 4 optically isolated output points (pts. Y0-Y3 on isolated commons C0-C3, respectively). The outputs must be wired so that positive current flows into Cn terminal and then out of the Yn terminal. (see the diagram on the following page and the schematic on page 2-31)

The module is configured, using CTRIO Workbench, to accommodate the user's application. The function of each input (counting, timing, reset, etc.) and output (pulse output, discrete output, etc.) is defined in the configuration of the module.

Refer to Chapters 4 and 5 to determine what input and output configurations are possible.



*Field device wiring must be compatible with the module configuration.*

See the notes below for further details about power source considerations, circuit polarities, and field devices. Also, refer to the specifications on pages 1-5 and 1-6 for more information.

Apply the labels that come with the I/O module to the I/O base terminals to properly identify the base terminal points.

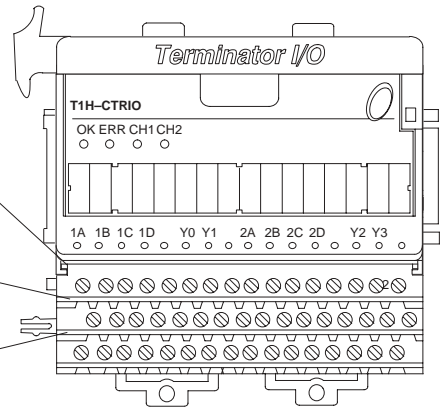
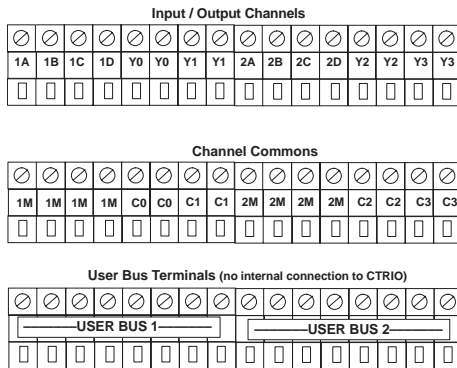

**Notes:**

- Inputs (1A, 1B, 1C, 1D and 2A, 2B, 2C, 2D) require user-provided 9-30VDC power sources. Terminals 1M and 2M are the commons for Channel 1 and Channel 2 inputs. Maximum current consumption is 12mA per input point.
- Polarity of the input power sources can be reversed. Consideration must be given, however, to the polarity of the field device. Many field devices are designed for only one polarity and can be damaged if power wiring is reversed.
- Outputs have one polarity only and are powered by user-provided 5-36VDC power sources. The maximum allowable current per output circuit is 1A.
- User Bus 1 and User Bus 2 are each an independent 8 wiring terminal bus. They can be used for additional power rail connections.

## T1H-CTRIO Input Field Wiring

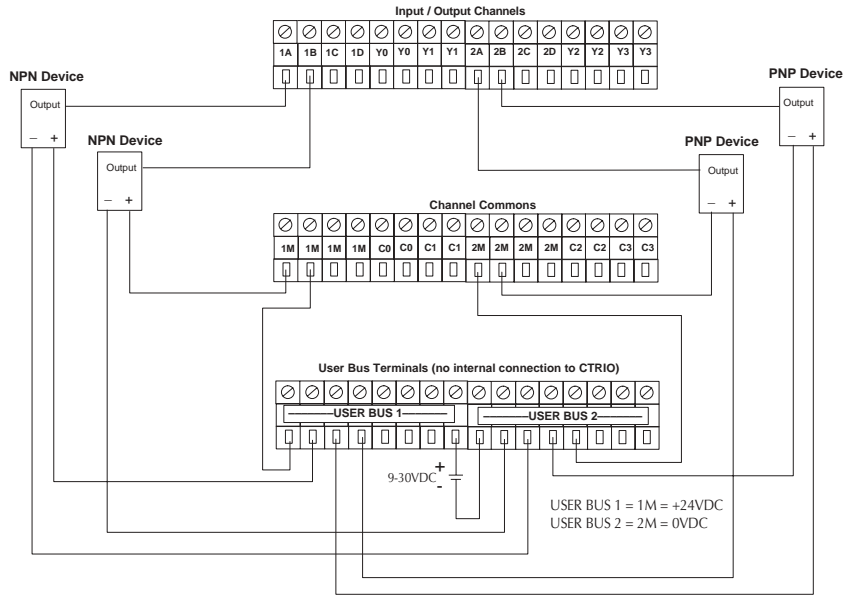

## T1H-CTRIO Output Field Wiring

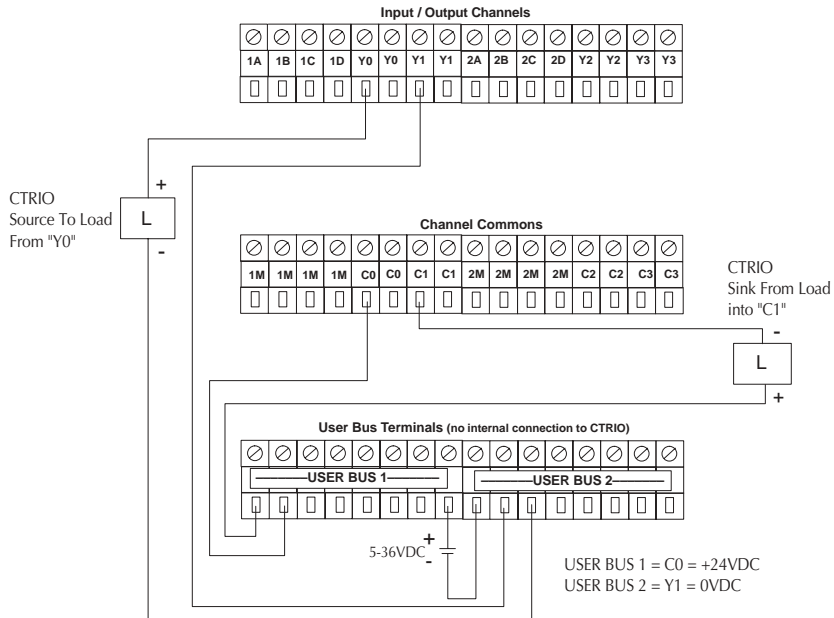

# T1H-CTRIO Quadrature Encoder Wiring Example

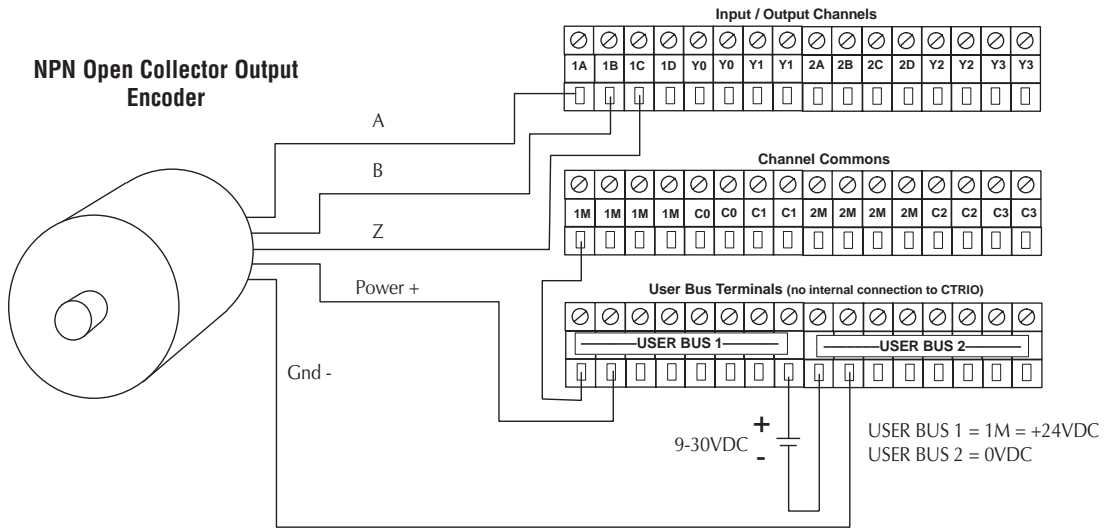

# T1H-CTRIO TTL Quadrature Encoder Field Wiring

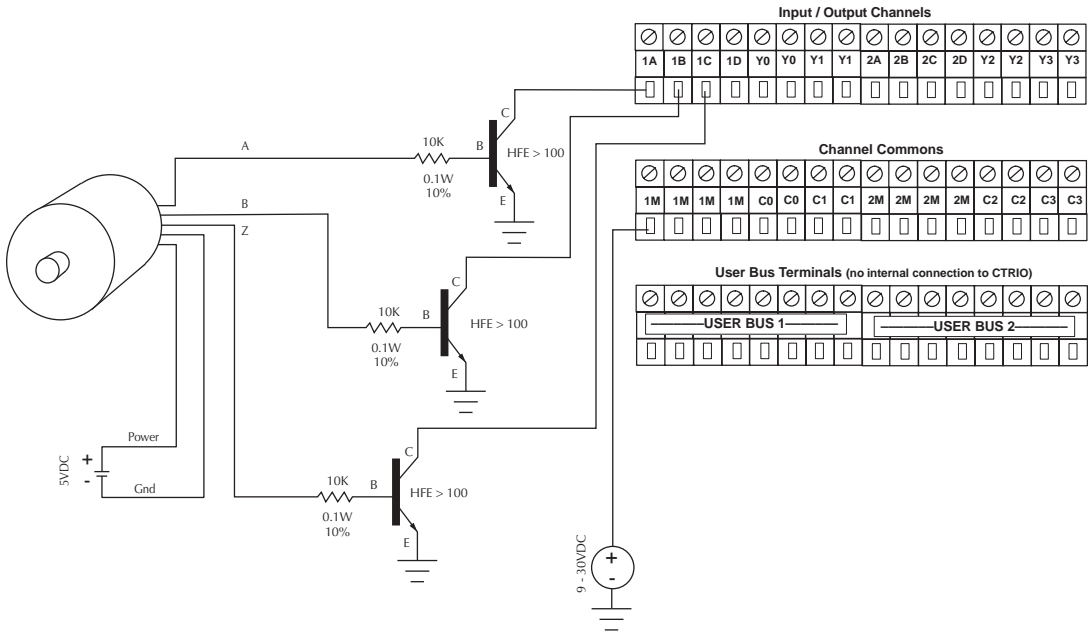

# T1H-CTRIO TTL Input Wiring

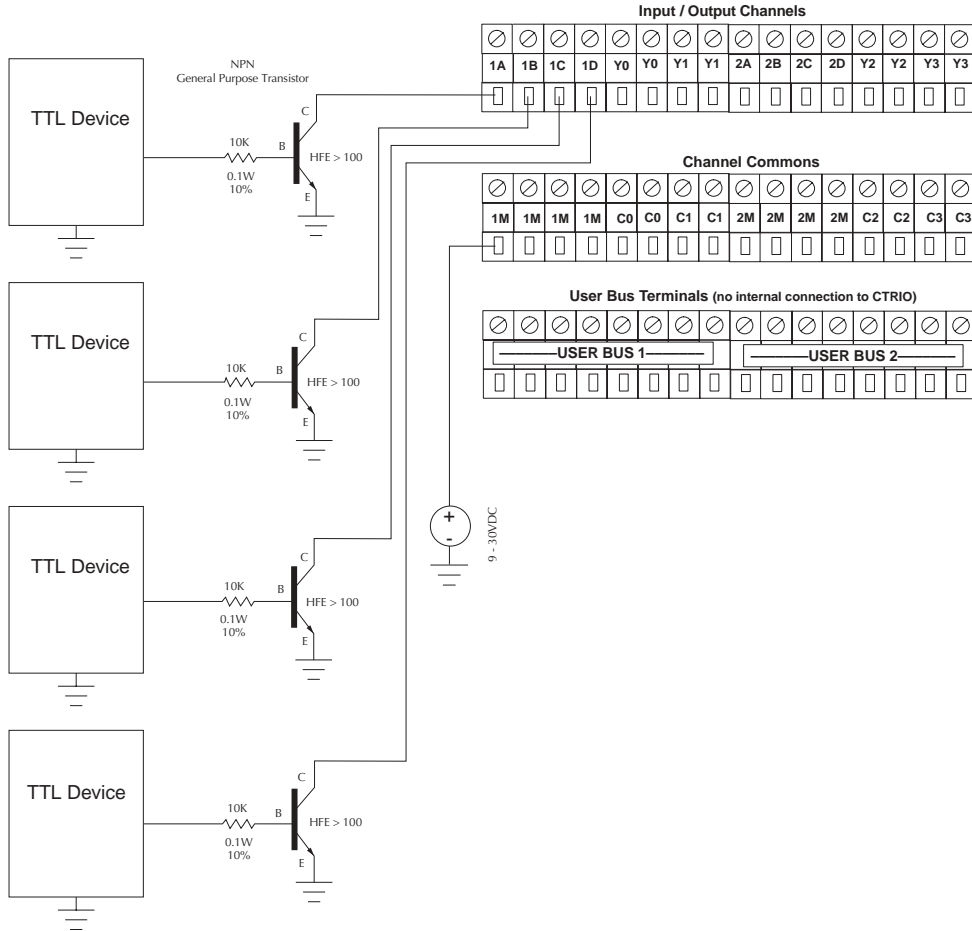

## T1H-CTRIO Output Wiring Schematic

The CTRIO outputs are individually isolated DC switches that can be used to break the high or the low side of a DC load.

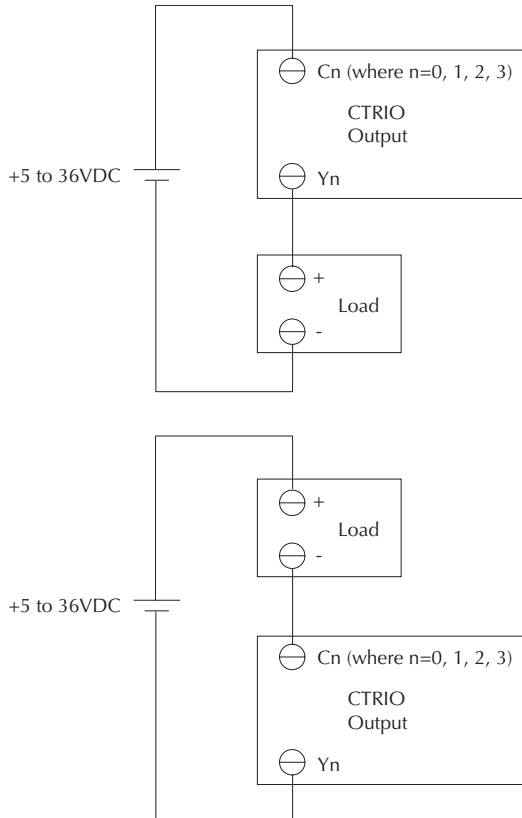

# T1H-CTRIO Stepper/Servo Drive Wiring Example

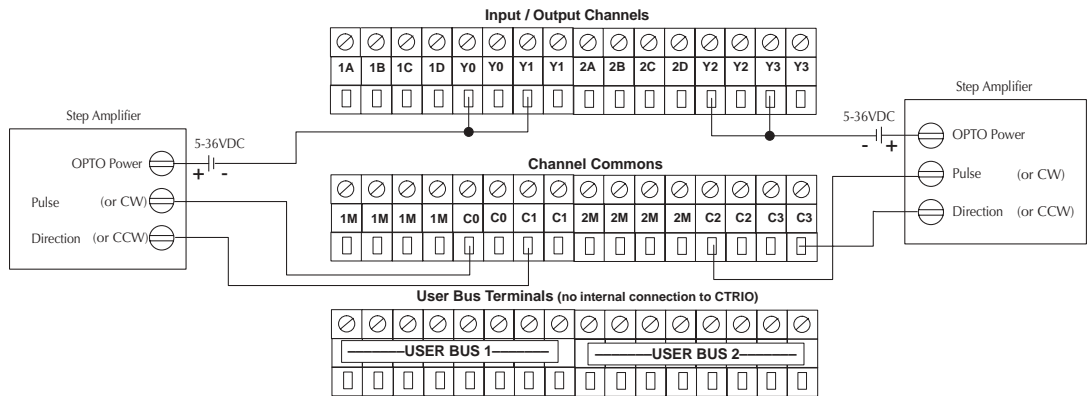

This example assumes that the Step Amplifier interface to be optocoupler LEDs (common anodes at the “OPTO Power” terminal) with internal current limiting resistors. This is a standard method, but you must consult you step amplifier documentation to ensure that this method is applicable.

# Solid State Input Device Wiring to H0/H2/H4/T1H-CTRIO

## NPN Field Device

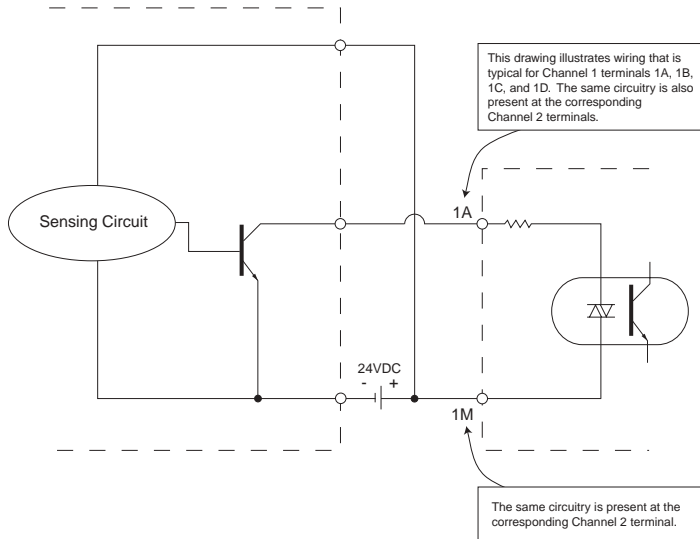

## PNP Field Device

