

PROGRAM CONTROL



In This Chapter...

Input Memory Map for Data Transfers from CTRIO to CPU	6-2
Output Memory Map for Data Transfers from CPU to CTRIO	6-4
I/O Map Dialog	6-7
Addressing Conventions (with V-memory Examples for DirectLOGIC PLCs)	6-12
Input Function Status/Control Bits and Parameters	6-13
Input Functions	6-16
Runtime Changes to CTRIO Configured Preset Tables	6-20
Pulse Output Status/Control Bits and Command Codes	6-24
Pulse Output Profiles	6-28
System Functions	6-45

Input Memory Map for Data Transfers from CTRIO to CPU

The following table shows which memory locations are used for memory transfers from the CTRIO module to the CPU. The starting memory location is defined by the user in the I/O Map within CTRIO Workbench. If you are using the *DirectLOGIC* CPU, you will use the memory address offsets in the second column. If you are using an H2-WinPLC, EBC, PBC, MODBUS, or DEVNETS in the CPU slot, you will use the non-PLC offsets in column one.

Data Type and Offset WinPLC, EBC, PBC, DEVNETS, MODBUS	Address for Inputs (DirectLOGIC)	Definition	Format	Bytes
dwX0	n+0	Ch 1/Fn 1 Parameter 1	DWord	4
dwX1	n+2	Ch 1/Fn 1 Parameter 2	DWord	4
dwX2	n+4	Ch 1/Fn 2 Parameter 1	DWord	4
dwX3	n+6	Ch 1/Fn 2 Parameter 2	DWord	4
dwX4	n+10	Ch 2/Fn 1 Parameter 1	DWord	4
dwX5	n+12	Ch 2/Fn 1 Parameter 2	DWord	4
dwX6	n+14	Ch 2/Fn 2 Parameter 1	DWord	4
dwX7	n+16	Ch 2/Fn 2 Parameter 2	DWord	4
bX0...7 bX8...15	n+20	Ch 1/Fn 1 Status (Low Byte) Ch 1/Fn 2 Status (High Byte)	Word	2
bX16...23 bX24...31	n+21	Ch 2/Fn 1 Status (Low Byte) Ch 2/Fn 2 Status (High Byte)	Word	2
bX32...39 bX40...47	n+22	Output 0 Status (Low Byte) Output 1 Status (High Byte)	Word	2
bX48...55 bX56...63	n+23	Output 2 Status (Low Byte) Output 3 Status (High Byte)	Word	2
bX64...71 bX72...79 bX80...87 bX88 95	n+24	System Functions Read/Write CTRIO Internal Registers (see p. 6-6 for bit definitions)	DWord	4

Input (n) Parameter Definitions

44 Total
Bytes

Parameter values are in Decimal format.

Configured Function from CTRIO Workbench	Parameter 1 Contents DWORD	Parameter 2 Contents DWORD
Non-scaled Counter	Raw Input Value	Not Used
Scaled Counter	Scaled Value (pos. or rate)	Raw Value
Non-scaled Counter with Capture	Raw Value	Captured Value
Scaled Counter with Capture	Scaled Value (pos. or rate)	Captured Value
Non-scaled Timer	Previous Time (us)	In Progress Time (us)
Scaled Timer	Scaled Interval (rate)	In Progress Time (us)
Pulse Catch	Not Used	Not Used



NOTE: For *DirectSOFT* users: the *I/O Map* dialog displays the exact memory locations in use by the *CTRIO* module. Within the *I/O Map* dialog you can print out a report of memory locations in use.

Input Function Status Bit Definitions

Input function offsets are listed in the order of Ch1/Fn1, Ch1/Fn2, Ch2/Fn1, Ch2/Fn2

Ch(x)/Fn(x) Status Bits (transfers from CTRIO to CPU)	Bit Offsets: WinPLC, EBC, PBC, DEVNETS, MODBUS	V-memory Offsets DirectLOGIC PLCs
Count Capture Complete Bit	0, 8, 16, 24	20.0, 20.8, 21.0, 21.8
Timer Capture Start	0, 8, 16, 24	20.0, 20.8, 21.0, 21.8
Timer Capture Complete (Timing) OR At Reset Value (Counting)	1, 9, 17, 25	20.1, 20.9, 21.1, 21.9
Timer "Timed Out" Bit	2, 10, 18, 29	20.2, 20.10, 21.2, 21.10
Pulse Catch Output Pulse State	0, 8, 16, 24	20.0, 20.8, 21.0, 21.8
Pulse Catch Start	1, 9, 17, 25	20.1, 20.9, 21.1, 21.9

Output Status Bit Definitions (for Preset Table Control)

Output Status Offsets are listed in the order of the Output 0 - Output 3.

Output(x) Status Bits (transfers from CTRIO to CPU)	Bit Offsets: WinPLC, EBC, PBC, DEVNETS, MODBUS	V-memory Offsets DirectLOGIC PLCs
Command Error	38, 46, 54, 62	22.6, 22.14, 23.6, 23.14
Command Complete	39, 47, 55, 63	22.7, 22.15, 23.7, 23.15

Output Status Bit Definitions (Pulse Output)

Output Status Offsets are listed in the order of the Output 0/1, 2/3.

Status Bit CTRIO to CPU	Bit Offsets: WinPLC, EBC, PBC, DEVNETS, MODBUS	V memory Offsets from Input Start (octal)
Output Enabled	32, 48	22.0, 23.0
Position Loaded	33, 49	22.1, 23.1
Output Suspended	34, 50	22.2, 23.2
Output Active	36, 52	22.4, 23.4
Output Stalled	37, 53	22.5, 23.5
Command Error	38, 54	22.6, 23.6
Command Complete	39, 55	22.7, 23.7

Output Memory Map for Data Transfers from CPU to CTRIO

The following table shows which memory locations are used for memory transfers from the CPU module to the CTRIO. The starting memory location is defined by the user in the I/O Map within CTRIO Workbench. If you are using a *DirectLOGIC* CPU, you will use the memory address offsets in the second column. If you are using a WinPLC, EBC, PBC, DEVNETS or MODBUS interface, you will use the non-PLC offsets in column one.

Data Type and Offset: WinPLC, EBC, PBC, DEVNETS, MODBUS	Address for Inputs (DirectLOGIC)	Definition	Format	Bytes
dwY0	n+0	Output 0 Parameter 3	DWord	4
dwY1	n+2	Output 1 Parameter 3	DWord	4
dwY2	n+4	Output 2 Parameter 3	DWord	4
dwY3	n+6	Output 3 Parameter 3	DWord	4
wY0	n+10	Output 0 Command	Word	2
wY1	n+11	Output 0 Parameter 1	Word	2
wY2	n+12	Output 0 Parameter 2	Word	2
wY3	n+13	Output 1 Command	Word	2
wY4	n+14	Output 1 Parameter 1	Word	2
wY5	n+15	Output 1 Parameter 2	Word	2
wY6	n+16	Output 2 Command	Word	2
wY7	n+17	Output 2 Parameter 1	Word	2
wY8	n+20	Output 2 Parameter 2	Word	2
wY9	n+21	Output 3 Command	Word	2
wY10	n+22	Output 3 Parameter 1	Word	2
wY11	n+23	Output 3 Parameter 2	Word	2
bY0...7 bY8...15	n+24	Ch 1/Fn 1 Control (Low Byte) Ch 1/Fn 2 Control (High Byte)	Word	2
bY16...23 bY24...31	n+25	Ch 2/Fn 1 Control (Low Byte) Ch 2/Fn 2 Control (High Byte)	Word	2
bY32...39 bY40...47	n+26	Output 0 Control (Low Byte) Output 1 Control (High Byte)	Word	2
bY48...55 bY56...63	n+27	Output 2 Control (Low Byte) Output 3 Control (High Byte)	Word	2
bX64...71 bX72...79 bX80...87 bX88 95	n+30	System Functions Read/Write CTRIO Internal Registers (see p. 6-6 for bit definitions)	DWord	4

Output (n) Parameter Definitions (Parameters are in decimal format)

52 Total Bytes

Configured Profile from CTRIO Workbench	Parameter 1 Contents WORD	Parameter 2 Contents WORD	Parameter 3 Contents DWORD
Trapezoidal	File # of stored profile	Not Used	Not Used
S-Curve, Symmetrical S-Curve	File # of stored profile	Not Used	Not Used
Dynamic Positioning	File # of stored profile	Not Used	Target Position
Dynamic Velocity	File # of stored profile	Not Used	Target Velocity
Home Search	File # of stored profile	Not Used	Not Used



NOTE: For *DirectSOFT* users: the I/O Map dialog displays the exact memory locations in use by the CTRIO module. Within the I/O Map dialog you can print out a report of memory locations in use.

Output (n) Parameter Definitions (Parameters are in decimal format unless specified)

Profiles Completely Controlled by User Program	Parameter 1 Contents WORD	Parameter 2 Contents WORD	Parameter 3 Contents DWORD
Velocity Mode	Initial Frequency	Duty Cycle	Number of Pulses (Hex)
Run to Limit Mode	Initial Frequency	Input Edge / Duty Cycle(Hex)	Not Used
Run to Position mode	Initial Frequency	Input Function Comparison and Duty Cycle (Hex)	Input Function Comparison Value

Input Function Control Bit Definitions

Input function offsets are listed in the order of Ch1/Fn1, Ch1/Fn2, Ch2/Fn1, Ch2/Fn2

Ch(n)/Fn(n) Control Bits (transfers from CPU to CTRIO)	Bit Offsets: WinPLC, EBC, PBC, DEVNETS, MODBUS	V-memory Offsets DirectLOGIC PLCs
Enable Count Capture	0, 8, 16, 24	24.0, 24.8, 25.0, 25.8
Enable Timer Capture	0, 8, 16, 24	24.0, 24.8, 25.0, 25.8
Enable Pulse Catch	0, 8, 16, 24	24.0, 24.8, 25.0, 25.8
Reset	1, 9, 17, 25	24.1, 24.9, 25.1, 25.9

Output Control Bit Definitions (for Preset Table Control)

Output Control Offsets are listed in the order of the Output 0 - Output 3.

Output(n) Control Bits (transfers from CPU to CTRIO)	Bit Offsets: WinPLC, EBC, PBC, DEVNETS, MODBUS	V-memory Offsets DirectLOGIC PLCs
Enable Output	32, 40, 48, 56	26.0, 26.8, 27.0, 27.8
Process Command	39, 47, 55, 63	26.7, 26.15, 27.7, 27.15

Output Control Bit Definitions (Pulse Output)

Pulse output control Offsets are listed in the order of Outputs 0/1, 2/3.

Output Control Bit transfers from CPU to CTRIO	Bit Offsets: WinPLC, EBC, PBC, DEVNETS, MODBUS	V memory Offsets from Output Start (octal)	Read as:
Enable Output	32, 48	26.0, 27.0	Level
Go to Position	33, 49	26.1, 27.1	Rising Edge
Suspend Output	34, 50	26.2, 27.2	Level
Direction	36, 52	26.4, 27.4	Level
Process Command	39, 55	26.7, 27.7	Rising Edge

Output Control Bit Definitions (Raw Mode)

Output Control Offsets are listed in the order of the Output 0 - Output 3.

Output(n) Control Bits (transfers from CPU to CTRIO)	Bit Offsets: WinPLC, EBC, PBC, DEVNETS, MODBUS	V-memory Offsets DirectLOGIC PLCs
Enable Output	32, 40, 48, 56	26.0, 26.8, 27.0, 27.8

System Functions Status Bit Definitions

From Table on page 6-2, *Direct*LOGIC Offset (n+24)

Status Bits (transfers from CTRIO to CPU)	V-memory Offsets DirectLOGIC PLCs
System Command Error	24.6
System Command Complete	24.7
Ch1 A	25.0
Ch1 B	25.1
Ch1C	25.2
Ch1D	25.3
Ch2 A	25.4
Ch2 B	25.5
Ch2 C	25.6
Ch2 D	25.7
Out 0 Active	25.8
Out 0 Mode	25.9
Out 1 Active	25.10
Out 1 Mode	25.11
Out 2 Active	25.12
Out 2 Mode	25.13
Out 3 Active	25.14
Out 3 Mode	25.15

System Functions Control Bit Definitions

From Table on page 6-4, *Direct*LOGIC Offset (n+30)

Control Bits (transfers from CPU to CTRIO)	V-memory Offsets DirectLOGIC PLCs
Process System Command	30.7

I/O Map Dialog

The I/O Map dialog is accessible from the main Workbench dialog. On the main Workbench dialog, click the button labeled I/O Map.

The I/O Map dialog divides the controller I/O memory used by the CTRIO module into three groups: Input Functions, Output Functions and System Functions.

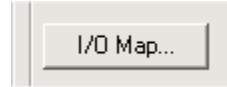

Just below the Map Display Mode field, you will see tabs to switch between Input Functions, Output Functions and System Functions.

Click on the Input Functions tab or Output Functions tab to display the CTRIO module's assigned input or output functions (quad counter, pulse catch, pulse out, discrete out, etc.). For each input and/or output function assigned, the I/O Map dialog displays the Input Data (CTRIO > Controller) addresses and Output Data (Controller > CTRIO) addresses based on the Map Display Mode and the starting I/O addresses specified. The memory map addresses displayed correspond to the offset addresses shown in the tables on the previous pages.

Click on the System Functions tab to display the System Functions addressing. The command bits are used when reading from and writing to the CTRIO's internal registers. The other bits can be used to monitor the status of each individual I/O point on the module.

I/O Map with *DirectLOGIC* PLC (2 ranges mode)

When using the CTRIO module with a *DirectLOGIC* PLC, enter the starting V memory location for the inputs and outputs in the appropriate fields at the top of the IO Map dialog. In the I/O Map dialog shown below, note that the Input, Output and Systems Functions addresses shown are in word and bit-of-word formats. Thus, word and bit-of-word addressing will need to be used in the ladder logic program to address the CTRIO's control and status words/bits.

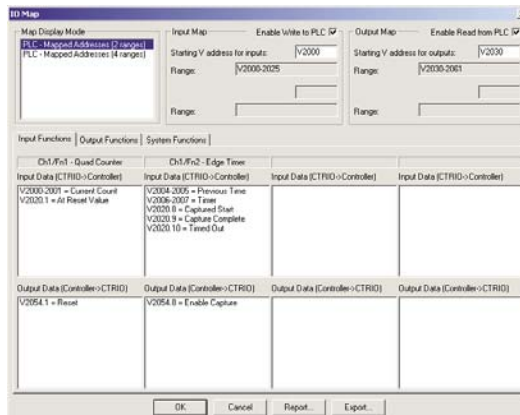

I/O Map with *Direct*LOGIC PLC (4 ranges mode)

When using the CTRIO module with a *Direct*LOGIC PLC in 4 ranges mode, enter the starting V-memory location for the *word* inputs and outputs and the starting V memory location for the *bit* inputs and outputs. Control relays (V40600 range) would usually be used for bit control.

In the I/O Map dialog below, note that Input, Output and Systems Functions addresses shown are in word and Control Relay formats. Thus, word and Control Relay addressing will need to be used in the ladder logic program to address the CTRIO control and status words/bits. Remember that the CTRIO will consume the address ranges listed in all four range fields.

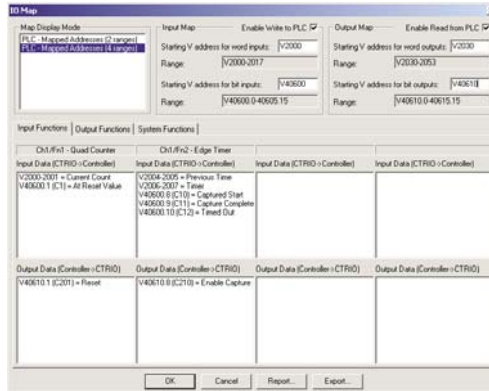

I/O Map with *Direct*LOGIC PLC with CTRIO in ERM/EBC Network

When using the CTRIO module with a *Direct*LOGIC PLC with the CTRIO module in an ERM/EBC network, first configure the ERM network using the ERM Workbench utility. Then, from ERM Workbench, enter the CTRIO's starting input and output V-Map addresses into the CTRIO Workbench's I/O Map starting V memory location for the *bit* inputs and outputs.



NOTE: If there is an 8-pt. discrete I/O module preceding the CTRIO module in the EBC base, enter the the appropriate starting V-memory bit I/O address in CTRIO Workbench with a V40xxx.8 address as shown in I/O Map example below to the right. This corrects the word offset created by the 8-pt. discrete I/O module. In the example below to the left, note that V40416 Hi(8-15) is the starting ERM Workbench CTRIO input V-Map location due to the 8-pt. discrete input module preceding the CTRIO module.

See Note Above

6

I/O Map with EBC/WinPLC

When using the CTRIO module in an EBC/WinPLC system (non PLC system), the addressing will be shown as Native EBC/WinPLC addresses or if using Think & Do, the addressing can be shown as Native Think & Do addresses. Just click on the desired mode in the Map Display Mode field. The 8-pt module offset described in the note above does not apply to EBC/WinPLC or EBC/Think&Do systems.

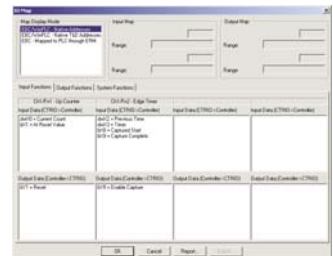

I/O Map with an H2-PBC or T1H-PBC Profibus DP Controller

When using the CTRIO module with an H2-PBC or T1H-PBC native Profibus addressing will be displayed in the I/O Map as shown below. For the T1H-PBC, the first two output bytes of memory are automatically reserved for the Hot Swap base-rescan feature. The H2-PBC does not support the Hot Swap feature.

H2-PBC IO Map

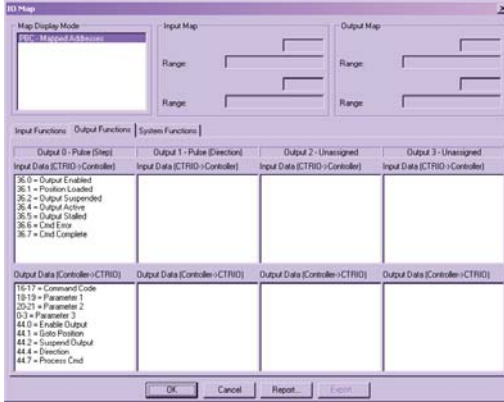

T1H-PBC IO Map

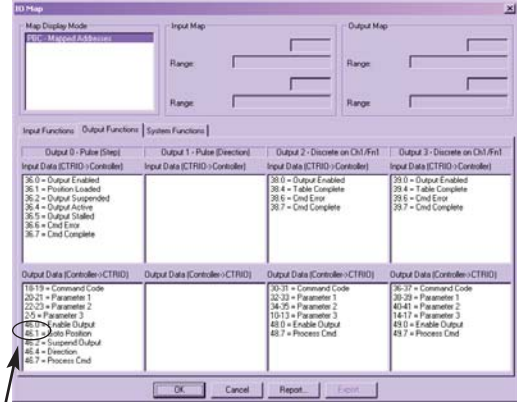

Note that output bytes 0-1 are reserved for the Hot Swap base rescan feature.

Creating an offline file for H2/T1H-CTRIO module

For the T1H-PBC, enter a 2 byte Output Offset to accommodate memory used by the Hot Swap base-rescan feature. This does not apply to an H2-PBC system. The example shown below assumes the T1H-CTRIO module is the first module in the system.

The CTRIO modules consume 44 bytes of input memory and 52 bytes of output memory. The maximum amount of I/O memory per H2/T1H-PBC station is 244 input bytes and 242 output bytes. You may need to refer to the Profibus User Manuals (H2-PBC-M / T1H-PBC-M) for information on bytes used by discrete and/or analog I/O modules to be able to determine the appropriate Starting input and output byte offset addresses for the CTRIO module.

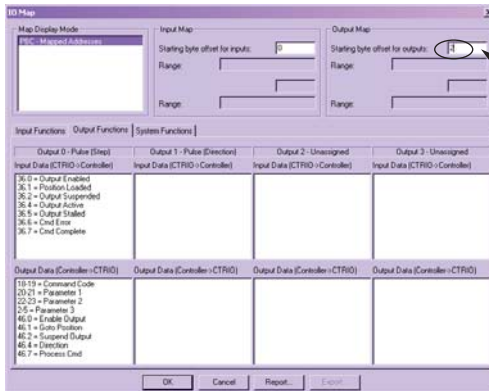

For the T1H-PBC, enter a 2 byte Output Offset to accommodate memory used by the Hot Swap base-rescan feature.

Printing a Memory Map Report

You can print an I/O Memory Map Report from the I/O Map dialog or save as a (.txt) file. Click on the Report button located near the bottom of the I/O Map dialog to display the Memory Map Report dialog.

The addresses listed in the Memory Map Report are a combination of the Input Functions, Output Functions and Systems Functions addresses shown in the I/O Map dialog. It is very convenient to have a printed list of the CPU/controller I/O memory used by the CTRIO module when attempting to write the control program.

Report...

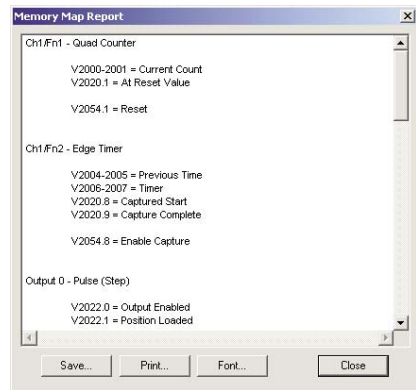

Exporting to DirectSOFT

You can export a (.csv) file containing addressing and nicknames used in the I/O Map dialog. Click on the Export button located near the bottom of the I/O Map dialog to display the Export to *DirectSOFT* dialog shown below on the left.

Export...

The (.csv) file (shown below on right) contains a combination of the Input Functions, Output Functions and Systems Functions addressing and nicknames shown in the I/O Map dialog. This file can be imported into your *DirectSOFT* ladder logic program (*DirectSOFT*>File>Import>Element Documentation).

If you have more than one CTRIO module in a system and intend to create a (.csv) file for more than one module, use the Add Prefix or Add Suffix option to distinguish one module's nicknames from the others. For example, add add prefix or suffix "S1" to identify the CTRIO module's nicknames in slot 1.

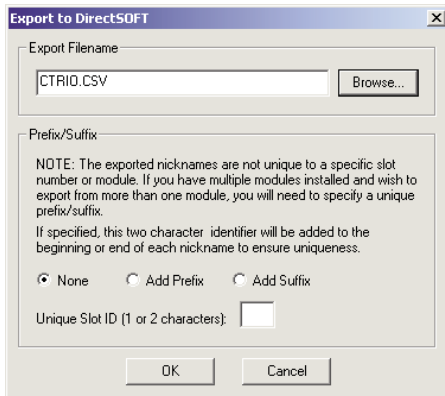

	A	B	C	D	E	F	G	H	I
1	V2000	C1F1_CurCount	Current Count						
2	B0020.1	C1F1_AtRstVal	At Reset Value						
3	B0054.1	C1F1_Reset	Reset						
4	V2004	C1F2_PrvTime	Previous Time						
5	V2006	C1F2_Timer	Timer						
6	B0020.8	C1F2_CaptStt	Captured Start						
7	B0020.9	C1F2_CptCmpl	Capture Complete						
8	B0020.10	C1F2_TimedOut	Timed Out						
9	B0054.8	C1F2_EnblCpt	Enable Capture						
10	B0022.0	Out0_OutEnbl	Output Enabled						
11	B0022.1	Out0_PosLoaded	Position Loaded						
12	B0022.2	Out0_OutSuspend	Output Suspended						
13	B0022.4	Out0_OutActiv	Output Active						
14	B0022.5	Out0_OutStall	Output Stalled						
15	B0022.6	Out0_CmdEmrr	Cmd Error						
16	B0022.7	Out0_CmdCmpl	Cmd Complete						
17	V2040	Out0_CmdCode	Command Code						
18	V2041	Out0_Param1	Parameter 1						
19	V2042	Out0_Param2	Parameter 2						
20	V2043	Out0_Param3	Parameter 3						
21	B0056.0	Out0_EnblOut	Enable Output						
22	B0056.1	Out0_GotoPos	Goto Position						
23	B0056.2	Out0_SuspOut	Suspend Output						
24	B0056.4	Out0_Direction	Direction						

Addressing Conventions

(with V-memory Examples for *Direct*LOGIC PLCs)

Example for Bit-accessed Data in PLC CPUs

In this example, the V-memory location V2524 contains a value equal to 514 in decimal.

514 decimal = 0202 Hex = 0000 0010 0000 0010 binary

The bit V2524.1 refers to the 2nd to the least significant bit (set to 1 in this example).

Likewise, V2524.9 refers to bit number 9, the 10th from the least significant bit (also set to 1 in this example).

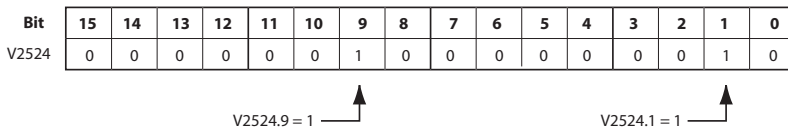

Addressing High and Low Byte of Word Parameters

In the following example, the V-memory location V2510 contains a value equal to 3 (decimal) in the high byte and 10 (decimal) in the low byte.

3 decimal = 03 Hex = 0000 0011 binary in the high byte, and

10 decimal = 0A Hex = 0000 1010 binary in the low byte.

This example could represent the Command Code “Edit Table Entry.” The value 03 (Hex) would represent the File number in the high byte, and the 0A (Hex) would represent the remainder of the Command Code in the low byte.

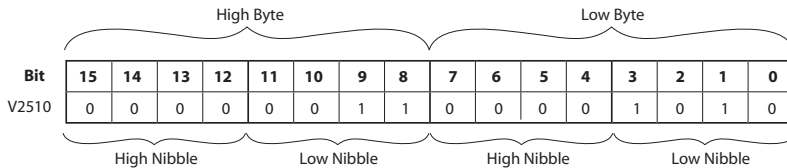

Addressing High and Low Word of DWord Parameters

Double Word parameters are addressed in a similar fashion to the high and low bytes of a Word Parameter. For example, a DWord that begins in V2300 consumes both V2300 and V2301. The Low Word is V2300, and the High Word is V2301.

Input Function Status/Control Bits and Parameters

Input Function Status Bit Definitions

Input function offsets are listed in the order of Ch1/Fn1, Ch1/Fn2, Ch2/Fn1, Ch2/Fn2

Ch(x)/Fn(x) Status Bits (transfers from CTRIO to CPU)	Bit Offsets: WinPLC, EBC, PBC, DEVNETS, MODBUS	V-memory Offsets DirectLOGIC PLCs
Count Capture Complete Bit	0, 8, 16, 24	20.0, 20.8, 21.0, 21.8
Timer Capture Start	0, 8, 16, 24	20.0, 20.8, 21.0, 21.8
Timer Capture Complete (Timing) OR At Reset Value (Counting)	1, 9, 17, 25	20.1, 20.9, 21.1, 21.9
Timer "Timed Out" Bit	2, 10, 18, 29	20.2, 20.10, 21.2, 21.10
Pulse Catch Output Pulse State	0, 8, 16, 24	20.0, 20.8, 21.0, 21.8
Pulse Catch Start	1, 9, 17, 25	20.1, 20.9, 21.1, 21.9

Input Function Control Bit Definitions

Input function offsets are listed in the order of Ch1/Fn1, Ch1/Fn2, Ch2/Fn1, Ch2/Fn2

Ch(n)/Fn(n) Control Bits (transfers from CPU to CTRIO)	Bit Offsets: WinPLC, EBC, PBC, DEVNETS, MODBUS	V-memory Offsets DirectLOGIC PLCs
Enable Count Capture	0, 8, 16, 24	24.0, 24.8, 25.0, 25.8
Enable Timer Capture	0, 8, 16, 24	24.0, 24.8, 25.0, 25.8
Enable Pulse Catch	0, 8, 16, 24	24.0, 24.8, 25.0, 25.8
Reset	1, 9, 17, 25	24.1, 24.9, 25.1, 25.9

Input Function Status DWord Parameters

Input function offsets are listed in the order of Ch1/Fn1, Ch1/Fn2, Ch2/Fn1, Ch2/Fn2 and are in decimal format.

DWord Status CTRIO to CPU	DWord Offsets: WinPLC, EBC, PBC, DEVNETS, MODBUS	V-memory Offsets from Output Start (octal)
DWord Parameter 1	0, 2, 4, 6	0, 4, 10, 14
DWord Parameter 2	1, 3, 5, 7	2, 6, 12, 16

Configured Function from CTRIO Workbench	Parameter 1 Contents DWORD	Parameter 2 Contents DWORD
Non-scaled Counter	Raw Input Value	Not Used
Scaled Counter	Scaled Value (pos. or rate)	Raw Value
Non-scaled Counter with Capture	Raw Value	Captured Value
Scaled Counter with Capture	Scaled Value (pos. or rate)	Captured Value
Non-scaled Timer	Previous Time (us)	In Progress Time (us)
Scaled Timer	Scaled Interval (rate)	In Progress Time (us)
Pulse Catch	Not Used	Not Used



NOTE: If you select the 'discrete on chx/fnx' option for an input channel using pulse catch mode, you will get a message when you exit the IO config screen noting 'pulse follower mode' or 'Pulse extension mode' for this output channel. This means only that the output will pulse for the specified duration when the input receives a sufficiently long pulse input.

Example Input Control/Status Bits and Parameter Register Addresses

The following tables provide example addresses based on V2000 selected for the base input address and V2030 selected for the base output address. The Input Functions discussed on the following pages use these example addresses.

Status Registers: Example using V2000 as base input address for Input Channel 1 (Status bits and DWords received from CTRIO to CPU)

Name	PLC Example 1: Bit-of-Word (see note 2) D2-250-1/260, D4-450	PLC Example 2: Control Relay (see note 1) D2-240	Value
Counter Capture Complete Bit	V2020.0	C160	ON when Capture is complete
Timer Capture Starting	V2020.0	C160	On when Timer Capture begins
Timer Capture Complete (Timing) OR At Reset Value (Counting)	V2020.1	C161	ON when Timer Capture complete
Timer "Timed Out" Bit	V2020.2	C162	On when specified Timer "Time Out" period is exceeded
Pulse Catch Output Pulse State	V2020.0	C160	ON for the specified pulse time if input pulse qualifies as a valid pulse
Pulse Catch Starting	V2020.1	C161	ON when pulse edge occurs
Parameter 1	V2001-V2000	V2001-V2000	Decimal
Parameter 2	V2003-V2002	V2003-V2002	Decimal

Control Registers: Example using V2030 as base output address for Input Channel 1 (Control bits sent from CPU to CTRIO)

Name	PLC Example 1: Bit-of-Word (see note 2), D2-250-1/260, D4-450	PLC Example 2: Control Relay (see note 1), D2-240 CPU	# Format
Enable Counter Capture	V2054.0	C260	Bit
Enable Timer Capture	V2054.0	C260	Bit
Enable Pulse Catch	V2054.0	C260	Bit
Reset	V2054.1	C261	Bit

Memory Mapping Example for D2-240 CPU



NOTE 1: The D2-240 CPU does not support bit-of-word addressing. The status and control bits must be mapped to control relay words. An example of mapping code is shown below.

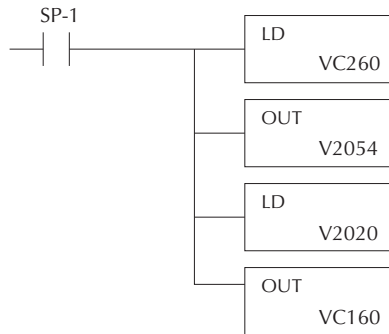

NOTE 2: For example, *DirectSOFT* uses *B2020.1* in the ladder code to indicate that you are addressing the second bit of V-memory register 2020. The “B” prefix indicates bit-of-word addressing.

Input Functions

Counter & Quadrature Counter

Parameters 1 and 2 are explained on page 6-16 and will be mapped to V2000 - V2003 in this example. If input D is configured for count Capture, the Enable Count Capture bit must be ON in order for input D to be able to snapshot the current count. The Count Capture Complete bit is used to indicate the acquisition has occurred. The program will need to turn OFF the Enable Capture and confirm the Capture Complete bit resets before attempting the next count capture. The Reset bit will reset raw and scaled values to the specified reset value. The last captured value, if applicable, will remain.

Name	PLC Control Outputs Base Addr = V2030 (Bit-of-Word)	PLC Status Inputs Base Addr = V2000 (Bit-of-Word)	PLC Control Outputs Base Addr = V2030 (Control Relay) D2-240	PLC Status Inputs Base Addr = V2000 (Control Relay) D2-240	Description
Parameter 1		V2001-V2000		V2001-V2000	refer to table on page 6-16
Parameter 2		V2003-V2002		V2003-V2002	refer to table on page 6-16
Counter Capture Complete		V2020.0		C160	On when Count Capture is complete (Available only when input D is configured for Capture input)
Enable Count Capture	V2054.0		C260		Turn ON to Capture Count (Available only when input D is configured for Capture input)
Reset	V2054.1		C261		Turn ON to Reset Counter Value to Reset Value
At Reset Value		V2020.1		C161	On when Counter is at Reset Value

Edge Timer and Dual Edge Timer

Parameters 1 and 2 are explained on page 6-16 and will be mapped to V2000 - V2003 in this example.

Standard Timers:

When the Enable Timer Capture bit is ON and the configured input edge occurs, the CTRIO will begin timing. The Timer Capture Starting bit will be ON while the timing is in progress and will turn OFF when the next configured input edge occurs and the Timer Capture Complete bit turns ON. The program will need to turn off the Enable Timer Capture bit, and confirm the Timer Capture Starting and Timer Capture Complete bits reset before attempting the next time capture cycle. Turning OFF the Enable Timer Capture bit resets the timers register values to zero.

Free Run Timers:

If the Free Run Timer option was configured, the Enable Timer Capture bit is not available. When the configured input edge occurs, the CTRIO will begin timing. The Timer Capture Starting bit will be ON while the timing is in progress and will turn OFF when the next configured input edge occurs. When this edge occurs, the Timer “in progress time” register resets to zero. The “previous time” register will always retain the most recent captured time value.

Name	PLC Control Outputs Base Addr = V2030 (Bit-of-Word)	PLC Status Inputs Base Addr = V2000 (Bit-of-Word)	PLC Control Outputs Base Addr = V2030 (Control Relay) D2-240	PLCStatus Inputs Base Addr = V2000 (Control Relay) D2-240	Description
Parameter 1		V2001-V2000		V2001-V2000	Previous Time
Parameter 2		V2003-V2002		V2003-V2002	In Progress Time
Timer Capture Starting		V2020.0		C160	On when Time Capture is in progress
Enable Timer Capture	V2054.0		C260		Turn ON to Enable Timer Capture Function (Not available when Free Run Timer option is selected)
Timer Capture Complete		V2020.1		C161	On when Timing is complete
Timer Timeout Bit		V2020.2		C162	

Edge and Dual Edge Timer Timeout Function

The Timer Timeout Function is available for use with standard and Free Run Timers. It is primarily used in Free Run timing of recurring events (rate, velocity calculations, etc.). The specified Timeout Period is in effect once the timer is enabled until receiving the first configured input edge. Then it is in effect until receiving the next edge of the timing input to complete the timing cycle.

Standard Timers:

Once the timer is enabled, the Timeout Bit is set if the time that it takes the CTRIO to see the configured input edge exceeds the specified Timeout Period. The program will need to turn off the Enable Timer Capture bit, and confirm the Timer Capture Complete bit and Timeout bit resets before attempting the next time capture cycle.

Once timing has been initiated, if the time before the CTRIO sees the next configured edge exceeds the specified Timeout Period, the Timeout bit is set. The Timer register values are reset to zero. The program will need to turn off the Enable Timer Capture bit, and confirm the Timer Capture Starting bit, Timer Capture Complete bit and the Timeout bit reset before attempting the next time capture cycle.

Free Run Timers:

The Timeout Bit is set if the time that it takes the CTRIO to see the configured input edge exceeds the specified Timeout Period. The Timeout bit resets when the next timing cycle begins. The “Previous Time” register value is reset to zero.

Once timing has been initiated, if the time before the CTRIO sees the next configured edge exceeds the specified Timeout Period, the Timeout bit is set. The Timer register values are reset to zero. The Timeout bit resets when the next timing cycle begins.

Pulse Catch Input Function

When the Enable Pulse Catch bit is ON and the configured input edge occurs, the CTRIO will begin timing and the Pulse Catch Starting bit will turn ON. If the input signal remains active for the specified qualification period, the Pulse Catch Output Pulse State bit will turn ON for the configured duration. If a discrete output is assigned to follow the pulse state, it will also turn ON for the configured duration. Unlike the Count or Time capture, the Pulse Catch function is automatically reset as long as the Enable Pulse Catch bit remains ON.

Name	PLC Control Outputs Base Addr = V2030 (Bit-of-Word)	PLC Status Inputs Base Addr = V2000 (Bit-of-Word)	PLC Control Outputs Base Addr = V2030 (Control Relay) D2-240	PLCStatus Inputs Base Addr = V2000 (Control Relay) D2-240	Description
Pulse Catch Starting		V2020.0		C160	On when Pulse Catch is in progress
Enable Pulse Catch	V2054.0		C260		Turn ON to Enable Pulse Catch Function
Pulse Catch Output Pulse State		V2020.1		C161	ON for the Pulse Output Width duration specified in Configure I/O



NOTE: The CTRIO will not recognize any input pulses while the Output Pulse is active. Take this into consideration when configuring the Pulse Output Width time.

Runtime Changes to CTRIO Configured Preset Tables

Presets and preset tables can be set up entirely within CTRIO Workbench so that no program control is necessary to assign discrete Preset Tables to CTRIO Input Functions.

You can make runtime edits to presets / preset tables from your control program. To make a runtime change, a series of commands must be executed which will pass new values to a preset table or call a different preconfigured table.

Command Codes are passed to the CTRIO module to effect the required edit. Each Command Code has its own syntax, and all Command Codes must be presented in a particular sequence:

The command code and associated parameters must be loaded into the appropriate memory locations.

A Process Command instruction must be passed to the CTRIO module.

A Command Complete signal must be received and the Command Error bit must stay at zero.

Finally, the Enable Output instruction must be passed to the CTRIO module.

Some changes require a combination of Command Codes so those changes must follow the steps above for each Command Code processed.

(Output Control and Status Offsets are listed in order of Output 0 - Output 3)

Control Bit (transfers from CPU to CTRIO)	Bit Offsets: WinPLC, EBC, PBC, DEVNETS, MODBUS	V-memory Offsets DirectLOGIC PLCs
Enable Output	32, 40, 48, 56	26.0, 26.8, 27.0, 27.8
Process Command	39, 47, 55, 63	26.7, 26.15, 27.7, 27.15

Status Bit (transfers from CTRIO to CPU)	Bit Offsets: WinPLC, EBC, PBC, DEVNETS, MODBUS	V-memory Offsets DirectLOGIC PLCs
Command Error	38, 46, 54, 62	22.6, 22.14, 23.6, 23.14
Command Complete	39, 47, 55, 63	22.7, 22.15, 23.7, 23.15

In order to process a command, first the program must load the Command and Required Word and DWord Parameters. Then the program should drive the Process Command bit to a 1 and look for the CTRIO to acknowledge the command with the Command Complete bit. Finally the program should remove the Process Command bit and set the Enable Output bit when appropriate. If the Command Error bit is received, the CTRIO was unable to process the command due to an illegal value in either the Command Code or Parameter fields.

Word Control CPU to CTRIO	Word Offsets: WinPLC, EBC, PBC, DEVNETS, MODBUS	V-memory Offsets from Output Start (octal)
Command Code	0, 6	10, 16
Word Parameter 1	1, 7	11, 17
Word Parameter 2	2, 8	12, 20

DWord Control CPU to CTRIO	DWord Offsets: WinPLC, EBC, PBC, DEVNETS, MODBUS	V-memory Offsets from Output Start (octal)
DWord Parameter 3	0, 2	0, 4

Command DirectLOGIC n+10	Code Hex/BCD	Parameter 1 (Word) DirectLOGIC n+11	Parameter 2 (Word) DirectLOGIC n+12 (decimal)	Parameter 3 (DWord) DirectLOGIC n+0/n+1 (decimal)
Load Table from RAM	10	File Number (decimal)	-	-
Clear RAM Table ⁶	11	-	-	-
Initialize RAM Table	12	Entry Type (decimal)	Pulse Time ¹	Preset Count/Time ⁴
Add Table Entry ⁶	13	Entry Type (decimal)	Pulse Time ¹	Preset Count/Time ⁴
Edit Table Entry ⁶	File & ² 14	Entry Num. & ² Entry Type ³ (Hex/BCD)	Pulse Time ¹	Preset Count/Time ⁴
Write RAM to ROM ⁶	99 ⁵	-	-	-
Edit and Reload ⁶	File & ² 15	Entry Num. & ² Entry Type ³ (Hex/BCD)	Pulse Time ¹	Preset Count/Time ⁴
Initialize Table on Reset ⁶	16	Entry Type (decimal)	Pulse Time ¹	Preset Count/Time ⁴
Run to Position ⁶	22	-	-	Target Position
Edit Level Response ⁶	30	Level Behavior (decimal)	Deadband	Level Rate Setting

¹ If appropriate for Entry Type (in ms).

² Field entries separated by an “&” are to be loaded in the high byte and low byte of that word. See example on page 6-7.

³ Entry types are defined below.

⁴ Follows format of Input DWord Parameter 1.

⁵ Flash ROM is rated for 100,000 writes.

⁶ Counter/Quad Counter Reset must be ON to perform the Edit.

Entry Number for Edit Table Entry Commands

The Entry Number refers to the position of the preset in the table sequence. The first preset is Entry Number “0,” the second preset is “1,” and so forth.

Entry Type for Edit Table Entry Commands

The Entry Type is defined according to the table below.

Entry Type	Code	Notes
Write Output ON (Set)	0	-
Write Output OFF (Reset)	1	-
Pulse Output ON	2	-
Pulse Output OFF	3	-
Toggle Output	4	-
Reset Function	5	Edits preset that resets count

Discrete Outputs Driven from a Scaled level (Edit Level Response: Command Code 30)

If a Counter or Timer function is scaled to produce a rate, alarm level settings can be used to trigger discrete outputs at values predetermined by the user. The alarm levels can be set within CTRIO Workbench or from the user's control program.

Additionally, a deadband percentage (in tenths of a percent) can be set to prevent the output from changing too frequently near the Rate Level threshold.

“ON when greater” condition example:

Consider a Discrete Output set to turn ON when a level gets to 100 with a 10% deadband. The output will turn ON when the level gets to 100. If the level drops, the output will stay on until the level drops below 90, where it will turn OFF.

“OFF when less” condition example:

Consider a Discrete Output set to turn “OFF when less” at 100. When the level gets to 100, the output turns OFF. If the level rises again, the output will stay OFF until the level gets to 110, where it will turn ON.

Edit the behavior of a Discrete Output triggered by a Rate Level by using the “Edit Level Response Command” (Command Code 30Hex).

The Level Behavior setting for Parameter 1 is given in the table below:

Level Behavior for Discrete Output	Parameter 1 Contents
ON when greater than Level Rate setting	0000 Hex
ON when less than Level Rate setting	0080 Hex
OFF when greater than Level Rate setting	0001 Hex
OFF when less than Level Rate setting	0081 Hex

The Deadband is written to Parameter 2 as a x10 integer (one implied decimal position). To achieve a 10.0% deadband, the control program needs to write 100 decimal (64 Hex) to Parameter 2.

The Level Rate setting is written to Parameter 3 in the same format as Input Parameter 1 of the CTRIO Function to which this Discrete Output has been assigned.

Load Preset Table Flowchart

The flowchart below provides the logical sequence necessary to load and execute a discrete output preset table.

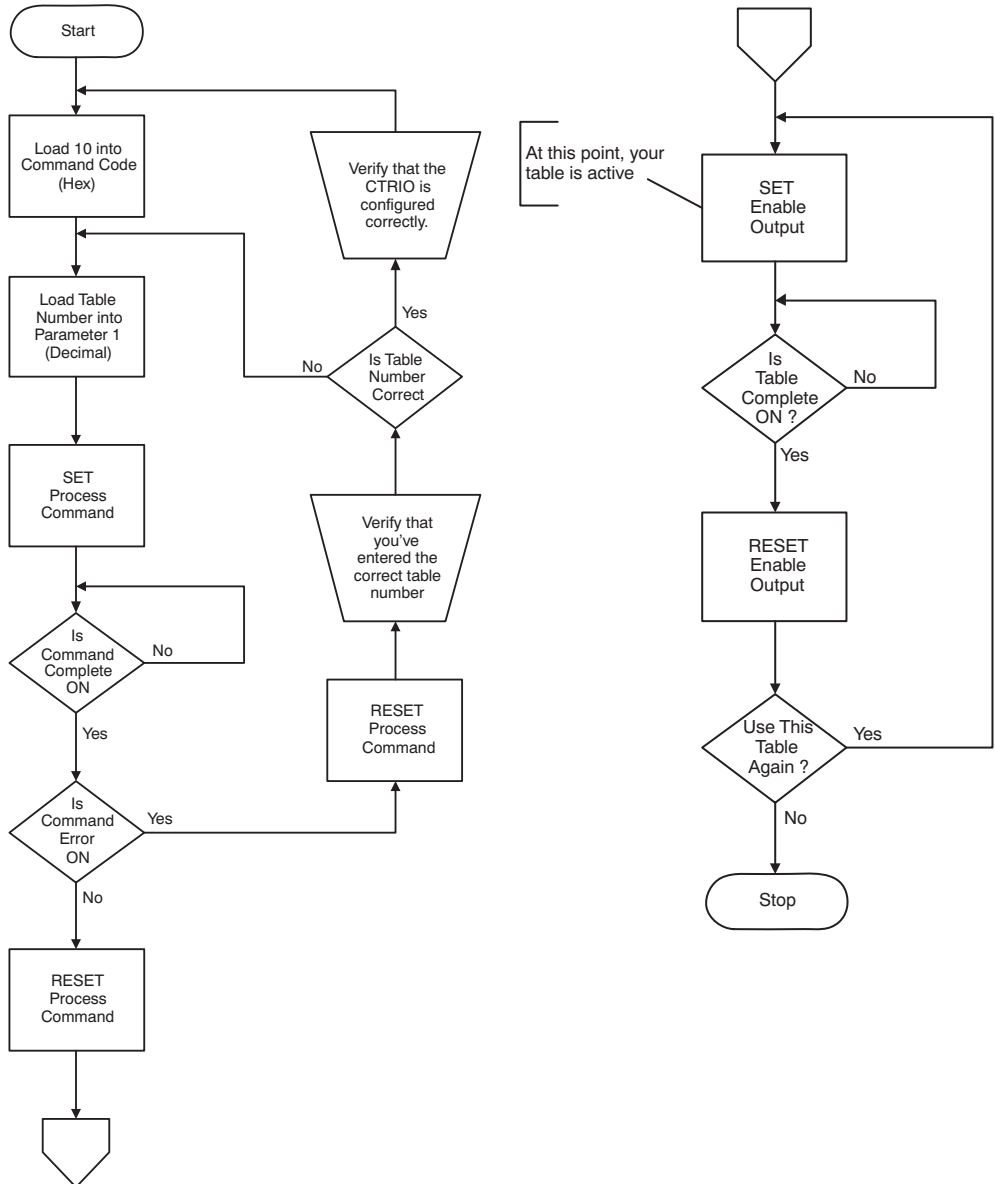

Pulse Output Status/Control Bits and Command Codes

Output Status Bit Definitions (Pulse Output)

Pulse output control Offsets are listed in the order of Outputs 0/1, 2/3.

Status Bit CTRIO to CPU	Bit Offsets: WinPLC, EBC, PBC, DEVNETS, MODBUS	V memory Offsets from Input Start (octal)
Output Enabled	32, 48	22.0, 23.0
Position Loaded	33, 49	22.1, 23.1
Output Suspended	34, 50	22.2, 23.2
Output Active	36, 52	22.4, 23.4
Output Stalled	37, 53	22.5, 23.5
Command Error	38, 54	22.6, 23.6
Command Complete	39, 55	22.7, 23.7

Output Control Bit Definitions (Pulse Output)

Pulse output control Offsets are listed in the order of Outputs 0/1, 2/3.

Control Bit CPU to CTRIO	Bit Offsets: WinPLC, EBC, PBC, DEVNETS, MODBUS	V memory Offsets from Output Start (octal)	Read as:
Enable Output	32, 48	26.0, 27.0	Level
Go to Position	33, 49	26.1, 27.1	Rising Edge
Suspend Output	34, 50	26.2, 27.2	Level
Direction	36, 52	26.4, 27.4	Level
Process Command	39, 55	26.7, 27.7	Rising Edge

Output Control (D)Words (Pulse Output)

Pulse output control Offsets are listed in the order of Outputs 0/1, 2/3.

Word Control CPU to CTRIO	Word Offsets: WinPLC, EBC, PBC, DEVNETS, MODBUS	V-memory Offsets from Output Start (octal)
Command Code	0, 6	10, 16
Word Parameter 1	1, 7	11, 17
Word Parameter 2	2, 8	12, 20

DWord Control CPU to CTRIO	Word Offsets: WinPLC, EBC, PBC, DEVNETS, MODBUS	V-memory Offsets from Output Start (octal)
DWord Parameter 3	0, 2	0, 4

Command Code and Parameter Definitions

Command	Code (Hex/BCD)	Word Parameter 1 (decimal)	Word Parameter 2	DWord Parameter 3
Load Table from ROM	10	Trapezoid or S-curve Symmetrical S-Curve Home Search File Number	-	-
Load Table from ROM	10	Dynamic Positioning File Number	-	Target Position (decimal)
Load Table from ROM	10	Dynamic Velocity File Number	-	Target Velocity (decimal)
Velocity Mode	20	Run Frequency (20Hz - 25KHz)	Duty Cycle (0 to 99)* (decimal)	Number of Pulses (BCD/Hex)
Run to Limit Mode	21	Run Frequency (20Hz - 25KHz)	Edge & Duty Cycle (0 to 99)* (Hex/BCD)	-
Run to Position Mode	22	Run Frequency (20Hz - 25KHz)	Compare Function & Duty Cycle (0 to 99)* (Hex/BCD)	Desired Input Function Value (decimal)

* A value of 0 will generate a duty cycle of 50%

Fields above separated by an “&” indicate a code with different definitions for each byte (high byte and low byte). For example, to enter the Pulse Output to Limit command, set the high byte of the Word Parameter 2 to the edge you wish to terminate the output pulses (see definition following), and set the low byte to the desired duty cycle.

In order to process a command, first the program must load the Command Code and required DWord, Word, and bit parameters. Then the program should drive the Process Command bit to a 1 and look for the CTRIO to acknowledge the command with the Command Complete bit. Finally, the program should remove the Process Command bit and set the Enable Output bit when appropriate. If the Command Error bit is received, the CTRIO was unable to process the command due to an illegal value in either the Command Code or parameter files.

DWord and Word values for pulse outputs are unsigned integers.

Status Bits: Example using V2000 as base input address For Output Channel 1 (Status bits received from CTRIO to CPU)

Name	PLC Example 1: Bit-of-Word (see note 2) D2-250-1/260, D4-450	PLC Example 2: Control Relay (see note 1) D2-240	Value
Output Enabled	V2022.0	C120	ON when Enable Output is ON
Position Loaded	V2022.1	C121	Used for Dynamic Positioning
Output Suspended	V2022.2	C122	ON when Output pulse is suspended
Output Active	V2022.4	C124	ON when Output is Pulsing
Output Stalled	V2022.5	C125	CTRIO Output Fault (should never be ON)
Command Error	V2022.6	C126	ON if Command or Parameters are invalid
Command Complete	V2022.7	C127	ON if Module Receives Process Command

Control Bits/Registers: Example using V2030 as base output address for Output Channel 1 (Control DWords, Words, and bits sent from CPU to CTRIO)

Name	PLC Example 1: Bit-of-Word (see note 2), D2-250-1/260, D4-450	PLC Example 2: Control Relay (see note 1), D2-240 CPU
Command Code	V2040	V2040
Parameter 1	V2041	V2041
Parameter 2	V2042	V2042
Parameter 3	V2031 - V2030	V2031 - V2030
Enable Output	V2056.0	C220
Go to Position	V2056.1	C221
Suspend Output	V2056.2	C222
Direction	V2056.4	C224
Process Command	V2056.7	C227

Memory Mapping Example for D2-240 CPU



NOTE 1: The D2-240 CPU does not support bit-of-word addressing. The status and control bits must be mapped to control relay words. An example of mapping code is shown below.

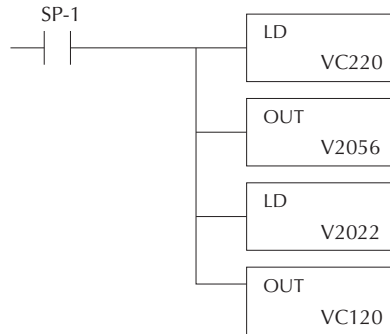

NOTE 2: For example, *DirectSOFT* uses *B2022.2* in the ladder code to indicate that you are addressing the third bit of V-memory register 2022. The “B” prefix indicates bit-of-word addressing.

Pulse Output Profiles

Loading a pre-defined Pulse Profile is the easiest method for pulse output motion control (Command Code = 0010 Hex/BCD). For the Trapezoid, S-Curve, Symmetrical S-Curve and Home Search profiles, all of the required characteristics of acceleration, run frequency, and total pulse count, etc. are entered in the CTRIO Workbench Pulse Profile entry window. For Dynamic Positioning and Dynamic Velocity profiles, the target position and target velocity are stored in a memory location in the controller. All other profile characteristics are entered in the CTRIO Workbench Pulse Profile entry window.

For Velocity Mode (Command Code = 0020 Hex/BCD), Run to Limit Mode (Command Code = 21 Hex/BCD) and Run to Position Mode (Command Code = 22 Hex/BCD) all profile parameters are stored in the controller's memory registers. No CTRIO Workbench Pulse Profile is required.

In order to process a command, first the program must load the Command Code and required DWord, Word, and bit parameters. Then the program should drive the Process Command bit to a 1 and look for the CTRIO to acknowledge the command with the Command Complete bit. Finally, the program should remove the Process Command bit and set the Enable Output bit when appropriate. If the Command Error bit is received, the CTRIO was unable to process the command due to an illegal value in either the Command Code or parameter files.

On the pages that follow, Pulse Profile and System Functions flowcharts are provided to give an overview of the steps needed to execute a pulse output profile or a SystemFunctions command. *Direct*LOGIC PLC addressing tables are also provided with CTRIO I/O data mapped in the word and CR bit areas of CPU memory shown on page 6-29.

Trapezoid, S-Curve, Symmetrical S-Curve, Home Search Profiles

For predefined Trapezoid, S-Curve, Symmetrical S-Curve and Home Search profiles, the program needs to prepare the Load Table command by selecting Command Code = 0010 Hex/BCD and setting Word Parameter 1 to the File number of the profile (example: File 1 Trapezoid 1). Then the program can set the Process Command bit and watch for the Command Complete bit. Then the program should clear the Process Command bit and set the Direction bit (if necessary) and finally the Enable Output bit to start the output pulses. Clearing the Enable Output bit will always suspend pulsing and reset any profile in progress to its beginning. Once complete, the profile remains loaded and can be restarted by clearing the Enable Output, changing the direction bit (if desired), and again setting the Enable Output. The flowchart on the next page provides the logical sequence necessary to execute a Trapezoidal, S-Curve, Symmetrical S-Curve or Home Search pulse profile.

For the Home Search routine, a CTRIO input must be assigned to Limit by the CTRIO Workbench Configure I/O dialog.

See Chapter 8 for a *Direct*LOGIC programming example that loads and runs a pulse profile using the bit/(D)word addressing in the table on the page 6-34.



NOTE: For a Home Search Profile: if you are at the home position and the Home Search profile is initiated, there will not be any pulse outputs.

Trapezoid, S-Curve, Symmetrical S-Curve and Home Search Flowchart

The flowchart below provides the logical sequence necessary to execute a Trapezoid, S-Curve, Symmetrical S-Curve or Home Search pulse profile.

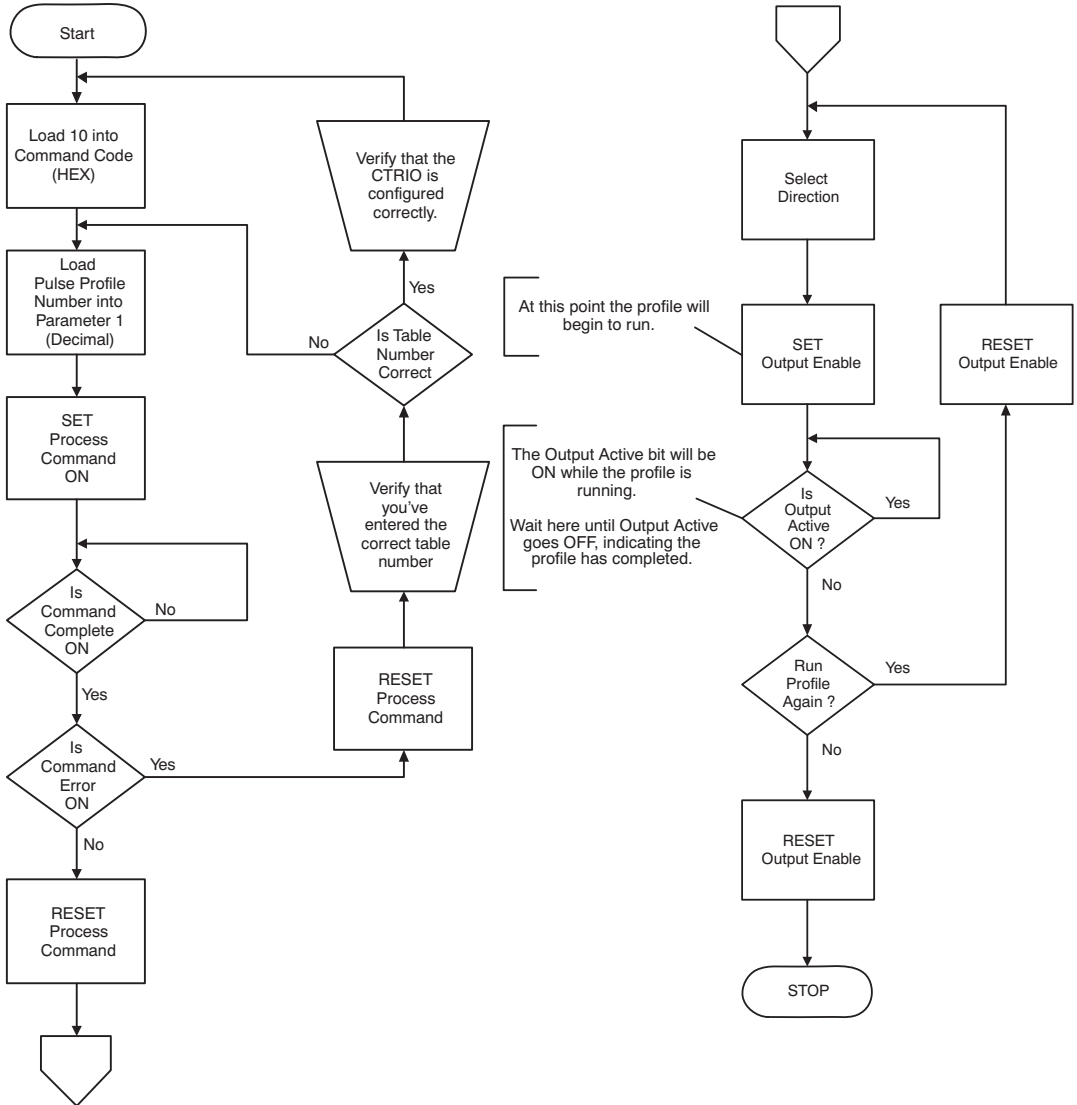

Running a Trapezoid, S-Curve, Symmetrical S-Curve Profile or Home Search Profile on CTRIO Y0 & Y1

Steps	Name	PLC Control Outputs Base Addr = V2030 (Bit-of-Word)	PLC Status Inputs Base Addr = V2000 (Bit-of-Word)	PLC Control Outputs Base Addr = V2030 (Control Relay) D2-240	PLC Status Inputs Base Addr = V2000 (Control Relay) D2-240	Action
1	Command Code	V2040		V2040		Set to 10 (Load Stored Profile)
2	Parameter 1	V2041		V2041		File # of stored profile, determined by user
3	Process Command	V2056.7		C227		Turn ON until Command Complete status bit is returned (see step 4)
4	Command Complete Status		V2022.7		C127	When ON, Profile is now loaded, clear Process Command bit (step 3)
5	Command Error		V2022.6		C126	ON if Command or Parameters are invalid
6	Set Direction	V2056.4		C224		Set ON or OFF for Direction of Rotation
7	Enable Output	V2056.0		C220		Turn ON to start pulses
8	Output Enable Status		V2022.0		C120	When ON, module is confirming Enable Output
9	Output Active Status		V2022.4		C124	When ON, module is pulsing. OFF with Enable Status ON = profile has completed
10	Disable Output	V2056.0		C220		Turn OFF when pulse status is OFF and Enable Status is ON
11	Suspend Output	V2056.2		C222		Turn ON to "pause" output pulses without resetting pulse count
12	Output Suspended		V2022.2		C122	ON when out pulse train has been suspended

Dynamic Positioning

For Dynamic Positioning, only the motion limits of Min Frequency, Max Frequency, and Acceleration rate come from the CTRIO Workbench Profile. After loading a Dynamic Position Profile, setting the Enable Output causes the CTRIO module to assume a position of 0 pulses. The program should write the next target position in DWord Parameter 3, and set the Go to Position bit. This will cause the CTRIO to set both the Pulses Active and the New Position Loaded bit and begin to output pulses. The number of pulses and direction are determined by the CTRIO based on the difference between the current location and the specified target location. The flowchart on the following page provides the logical sequence necessary to execute a Dynamic Positioning pulse profile.

The program can monitor the state of the Pulses Active bit and the New Position Loaded bit to determine when the new position has been attained. The New Position Loaded status bit will always follow the state of the Load/Seek New Position control bit. This status bit should be used to signal the program that the CTRIO has received the new state of the control bit.

Position Loaded Status Bit V40622.1 or C441	Pulses Active Status Bit V40622.0 or c440	CTRIO Dynamic Position Pulse Output State
0	0	Idle
1	1	Go To Position Acknowledged, Pulsing
0	1	Still Pulsing, Go To Position Control Bit is OFF
1	0	Go To Position Acknowledged, Position Attained

You do not have to wait on the CTRIO to complete a move that is in progress before loading the next target location. After the GoTo Position is acknowledged, the program can load the next position into the DWord Parameter 3. When Pulses Active Status goes to 0, then setting the GoTo Position control bit will again start the output toward the new position. The CTRIO moves to the new position relative to its previous position as long as the Enable Output control bit remains set. Clearing the Enable Output bit will disable output pulsing and reset the current position to 0.

See Chapter 8 for a *DirectLOGIC* programming example that executes a Dynamic Positioning pulse profile using the bit/(D)word addressing in the table on page 6-37.

The sign of the value in the Target Position register (Parameter 3) determines the direction of the pulse train output. In the *DirectLOGIC* programming example to the right, BCD 5000 is converted to decimal -5000 when C0 is turned ON. You could load (LD) a V memory location instead of using a constant as shown in the example.

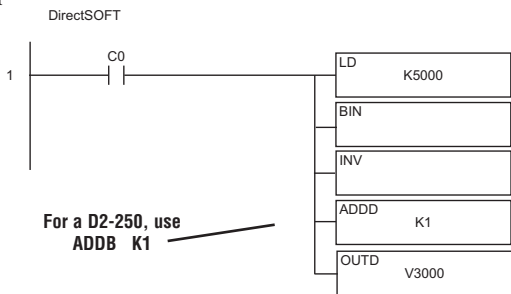

Dynamic Positioning Flowchart

The flowchart below provides the logical sequence necessary to execute a Dynamic Positioning pulse profile.

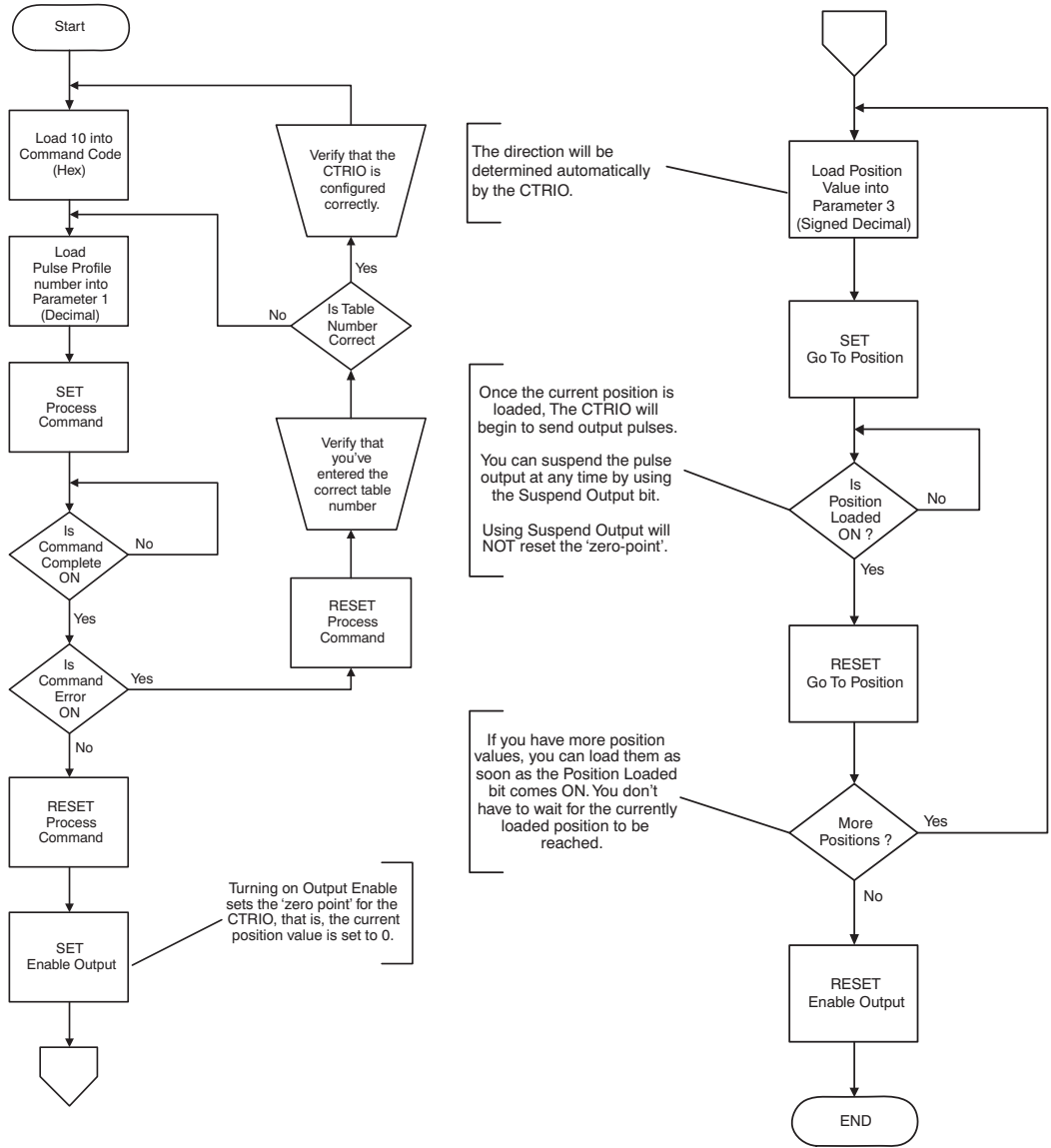

Dynamic Positioning using the CTRIO Y0 and Y1

Steps	Name	PLC Control Outputs Base Addr = V2030 (Bit-of-Word)	PLC Status Inputs Base Addr = V2000 (Bit-of-Word)	PLC Control Outputs Base Addr = V2030 (Control Relay) D2-240	PLC Status Inputs Base Addr = V2000 (Control Relay) D2-240	Action
1	Command Code	V2040		V2040		Set to 10 (Load Stored Profile)
2	Parameter 1	V2041		V2041		File # of desired Dynamic Positioning Profile
3	Process Command	V2056.7		C227		Turn ON until Command Complete status bit is returned (see step 4)
4	Command Complete Status		V2022.7		C127	When ON, Profile is now loaded, clear Process Command bit (step 3)
5	Command Error		V2022.6		C126	ON if Command or Parameters are invalid
6	Enable Output	V2056.0		C220		Turn ON to assume 0 position, Turn OFF to disable pulses and zero position
7	Output Enable Status		V2022.0		C127	When ON, pulses are now enabled and last position is retained
8	Parameter 3	V2031 / V2030		V2031 / V2030		Target position: User defined (DWord)
9	Go To Position	V2056.1		C221		Starts pulses with direction to obtain the new position relative to previous position.
10	Position Loaded Status		V2022.1		C121	When ON, Go To position is acknowledged
11	Output Active Status		V2022.4		C124	When ON, module is pulsing, OFF with Position Loaded status ON = new position move has completed
12	Go To Position	V2056.1		C221		Turn OFF to be ready to load a new position
13	Suspend Output	V2056.2		C222		Turn ON to "pause" output pulses without resetting pulse count
14	Output Suspend		V2022.2		C122	ON when out pulse train has been suspended

To seek the next position, repeat steps 7-10.

Dynamic Velocity

For Dynamic Velocity, the motion limits of clockwise acceleration and deceleration, and counter clockwise acceleration and deceleration come from the CTRIO Workbench Profile.

The target velocity is stored in a register in the CPU/controller.

The program needs to prepare the Load Table command by selecting Command Code = 0010 Hex/BCD, set Word Parameter 1 to the File number of the profile (example: File 3 Dynamic Velocity 1) and set Word Parameter 3 to the desired target velocity. Then the program can set the Process Command bit and watch for the Command Complete bit. Then the program should clear the Process Command bit. Set the Enable Output bit to start the output pulses. The velocity can be changed “on the fly” by entering a different value into the target velocity register. The velocity will ramp up/down to the new target velocity at the specified accel/decel rates. Clearing the Enable Output bit will always suspend pulsing.

See Chapter 8 for a *DirectLOGIC* programming example that executes a Dynamic Velocity pulse profile using the bit/(D)word addressing in the table below.

Dynamic Velocity using the CTRIO Y0 and Y1

Steps	Name	PLC Control Outputs Base Addr = V2030 (Bit-of-Word)	PLC Status Inputs Base Addr = V2000 (Bit-of-Word)	PLC Control Outputs Base Addr = V2030 (Control Relay) D2-240	PLC Status Inputs Base Addr = V2000 (Control Relay) D2-240	Action
1	Command Code	V2040		V2040		Set to 10 (Load Stored Profile)
2	Parameter 1	V2041		V2041		File # containing cw accel/decel and ccw accel/decel
3	Process Command	V2056.7		C227		Turn ON until Command Complete status bit is returned
4	Command Complete Status		V2022.7		C127	When ON, Profile is now loaded, clear Process Command bit
5	Command Error		V2022.6		C126	ON if Command or Parameters are invalid
6	Enable Output	V2056.0		C220		Turn ON to ramp to target velocity, Turn OFF to disable pulses.
7	Parameter 3	V2031 / V2030		V2031 / V2030		Target velocity: User defined (DWord)
8	Output Active Status		V2022.4		C124	When ON, module is pulsing
9	Suspend Output	V2056.2		C222		Turn ON to “pause” output pulses without resetting pulse count
10	Output Suspended		V2022.2		C122	ON when out pulse train has been suspended

The sign of the value in the Target Velocity register (Parameter 3) determines the direction of the pulse train output. In the DirectLOGIC programming example to the right, BCD 5000 is converted to decimal -5000 when C0 is turned ON. You could load (LD) a V memory location instead of using a constant as shown in the example.

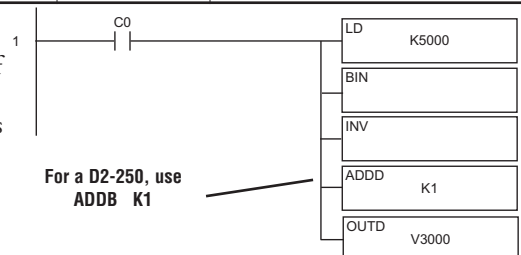

Dynamic Velocity Mode Flowchart

The flowchart below provides the logical sequence necessary to execute a Dynamic Velocity pulse profile.

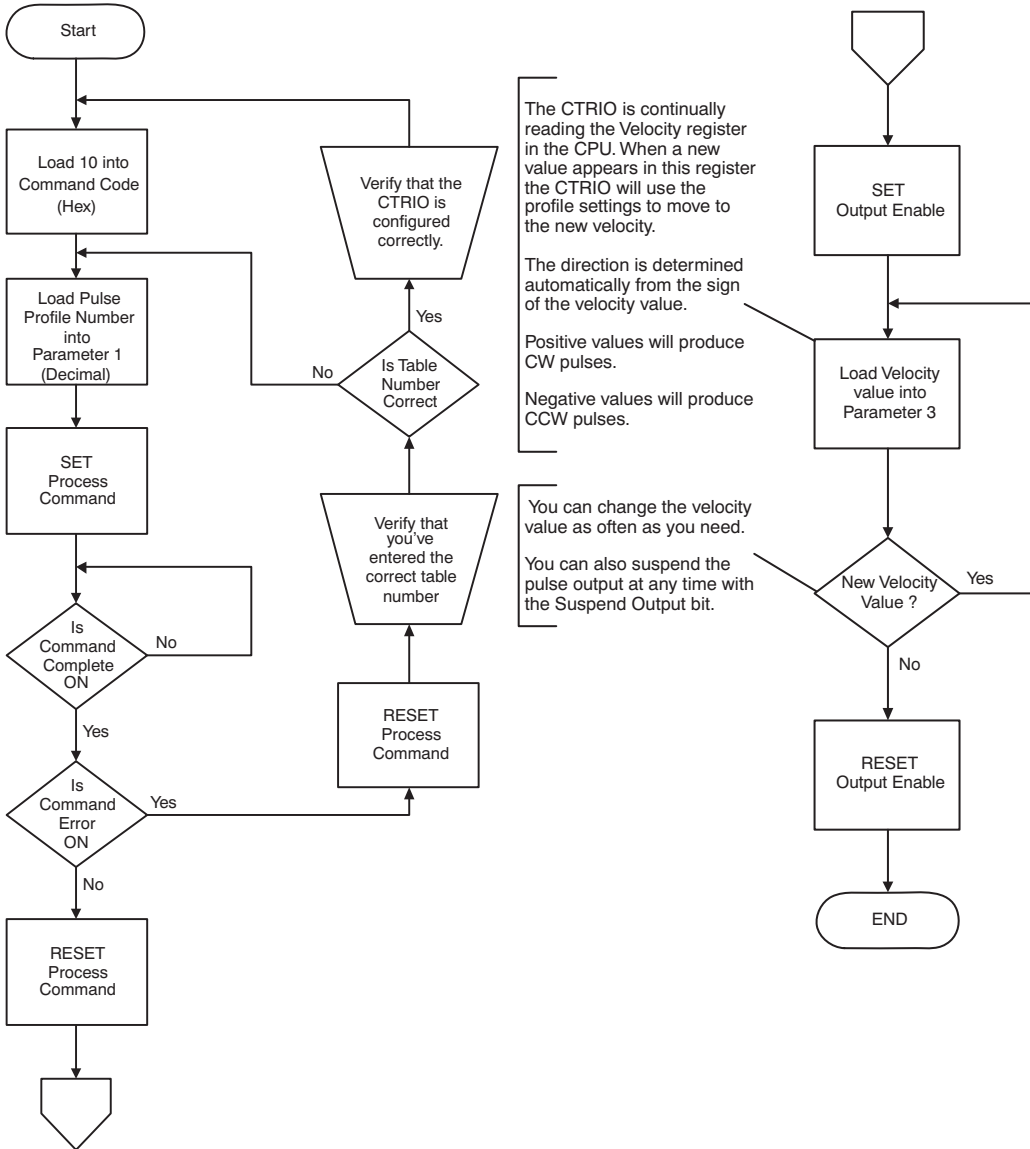

Velocity Mode



NOTE: Velocity Mode controls the pulse outputs directly from the CPU/controller program. No CTRIO Workbench Pulse Profile is required for this mode.

Velocity Mode command (Command = 0020 Hex/BCD) allows a specified number of pulse output counts or the number of Pulses can be set to “FFFFFFF” in Hex for unlimited pulse counts. Leaving the Duty Cycle set to 0 achieves the default (50%), otherwise it can be set in 1% increments by writing this value from 1 to 99 decimal. After this command is processed, the Run Frequency and Duty Cycle fields can be adjusted by direct access. In order to change directions from Pulse Output in “Velocity” mode, the Enable Output bit must first be cleared (which stops the Pulse Outputs). Then after the new direction bit is written, the Enable Output bit can be set to resume pulsing. The flowchart on the following page provides the logical sequence necessary to execute a Velocity Mode pulse profile.

See Chapter 8 for a *Direct*LOGIC programming example that executes a Velocity Mode pulse profile using the bit/(D)word addressing in the table below.

Velocity Mode control on CTRIO Y0 & Y1

Steps	Name	PLC Control Outputs Base Addr = V2030 (Bit-of-Word)	PLC Status Inputs Base Addr = V2000 (Bit-of-Word)	PLC Control Outputs Base Addr = V2030 (Control Relay) D2-240	PLC Status Inputs Base Addr = V2000 (Control Relay) D2-240	Action
1	Command Code	V2040		V2040		Set to 20 Hex (Pulse at Velocity)
2	Parameter 1	V2041		V2041		Set initial run frequency (20Hz-25000Hz) decimal
3	Parameter 2	V2042		V2042		Duty cycle (1-99) (can leave 0 for 50%) decimal
4	Parameter 3	V2031 / V2030		V2031 / V2030		Number of pulses (DWord); set to FFFF FFFF for no limit, Hex
5	Set Direction	V2056.4		C224		Set ON or OFF for Direction of Rotation
6	Process Command	V2056.7		C227		Turn ON Command Complete status bit is returned (see step 4)
7	Command Status		V2022.7		C127	When ON, command has been accepted, clear Process Command bit (step 3)
8	Command Error		V2022.6		C126	ON if Command or Parameters are invalid
9	Enable Output	V2056.0		C220		Turn ON to start pulses
10	Disable Output	V2056.0		C220		Turn OFF to start pulses
11	Suspend Output	V2056.2		C222		Turn ON to “pause” output pulses without resetting pulse count
12	Output Suspended		V2022.2		C122	ON when out pulse train has been suspended

While Velocity Mode Control is running, Run Frequency (step 2) and Duty Cycle (step 3) may be actively changed simply by writing a new Parameter value. Since no accel/decel parameters are specified in this profile, the output change is a step response.

Velocity Mode Flowchart

The flowchart below provides the logical sequence necessary to execute a Velocity Mode pulse profile.

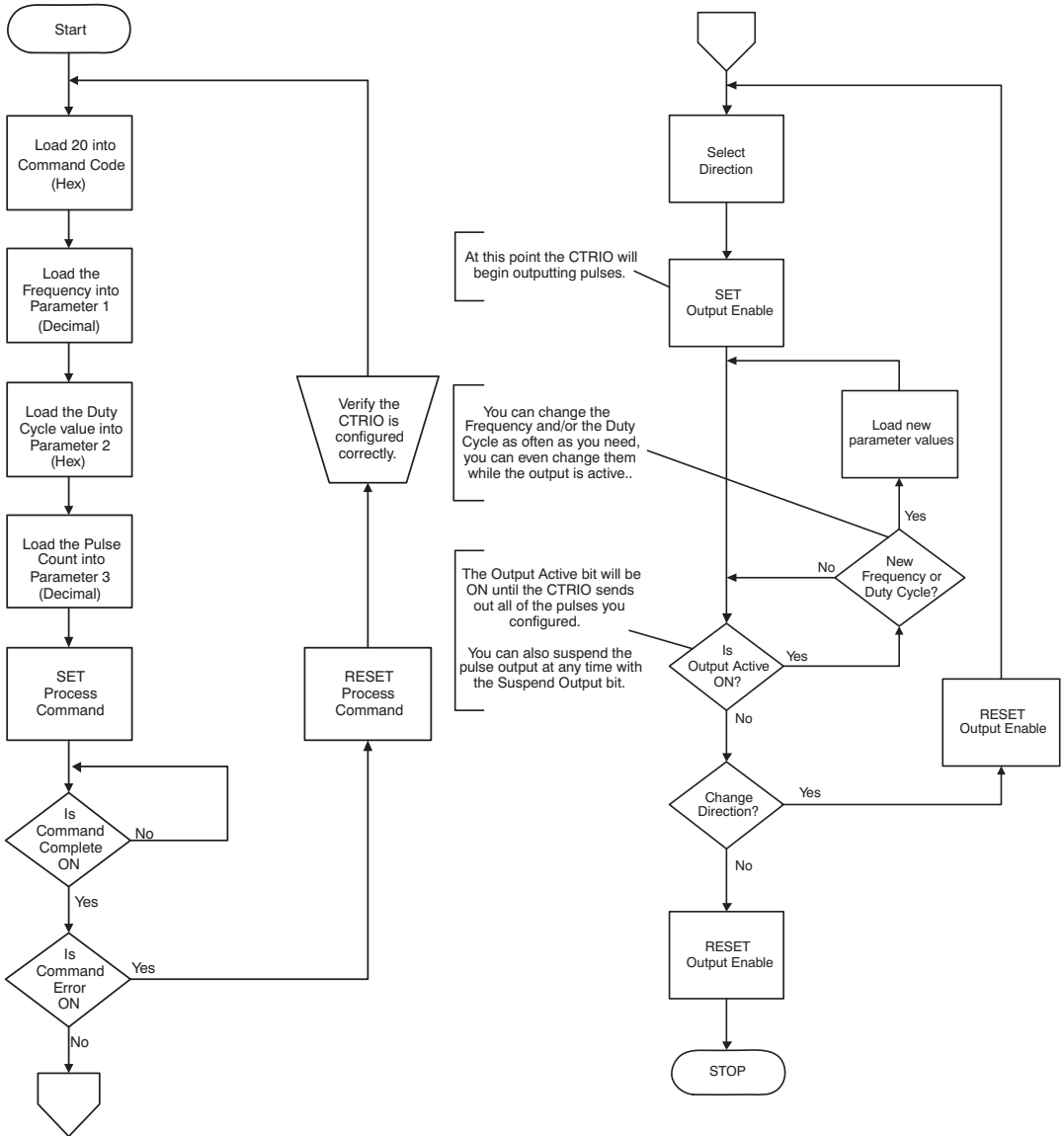

Run to Limit Mode



NOTE: Run to Limit Mode controls the pulse outputs directly from the CPU/controller program. No CTRIO Workbench Pulse Profile is required for this mode.

The Run to Limit (Command = 0021Hex/BCD) can be used to seek limit positions or for Home Search routines. You may want to consider using the Home Search Pulse Profile(s) created using Workbench unless you need the CPU/controller to control the entire profile and parameters, etc. The CTRIO input must be assigned for Limit by the CTRIO Workbench utility.

Set Word Parameter 1 to the desired Frequency. Set Word Parameter 2 Low Byte to the Duty Cycle and the High Byte to the Edge to Seek as defined below. Leaving the Duty Cycle set to 0 achieves the default (50%), otherwise it can be set in 1% increments by writing this value from 1 to 99 Hex/BCD.

The flowchart on the following page provides the logical sequence necessary to execute a Run to Limit pulse profile.

See Chapter 8 for a *Direct*LOGIC programming example that executes a Run to Limit Mode pulse profile using the bit/(D)word addressing in the table on page 6-44.

Parameter 2

Word Parameter 2 defines three elements of the Run to Limit routine. Bits 13 and 12 determine which edge(s) to terminate Output Pulses and Bits 9 and 8 determine which CTRIO Input terminal to use for the limit. The low byte specifies the duty cycle.

Edge to Seek	Parameter 2 Bits 13 & 12	Parameter 2 Bits 9 & 8	Parameter 2 (Hex) (Duty cycle at 50%)
Rising Edge Ch1 C	00	00	0000
Falling Edge Ch1 C	01	00	1000
Both Edge Ch1 C	10	00	2000
Rising Edge Ch1 D	00	01	0100
Falling Edge Ch1 D	01	01	1100
Both Edge Ch1 D	10	01	2100
Rising Edge Ch2 C	00	10	0200
Falling Edge Ch2 C	01	10	1200
Both Edge Ch2 C	10	10	2200
Rising Edge Ch2 D	00	11	0300
Falling Edge Ch2 D	01	11	1300
Both Edge Ch2 D	10	11	2300

Edge(s)	Bits 15..12	CTRIO Input	Bits 11..8
Rising	0000, 0Hex	Ch 1 C	0000, 0Hex
Falling	0001, 1Hex	Ch 1 D	0001, 1Hex
Both	0010, 2Hex	Ch 2 C	0010, 2Hex
		Ch 2 D	0011, 3Hex

Run to Limit Mode Flowchart

The flowchart below provides the logical sequence necessary to execute a Run to Limit Mode pulse profile.

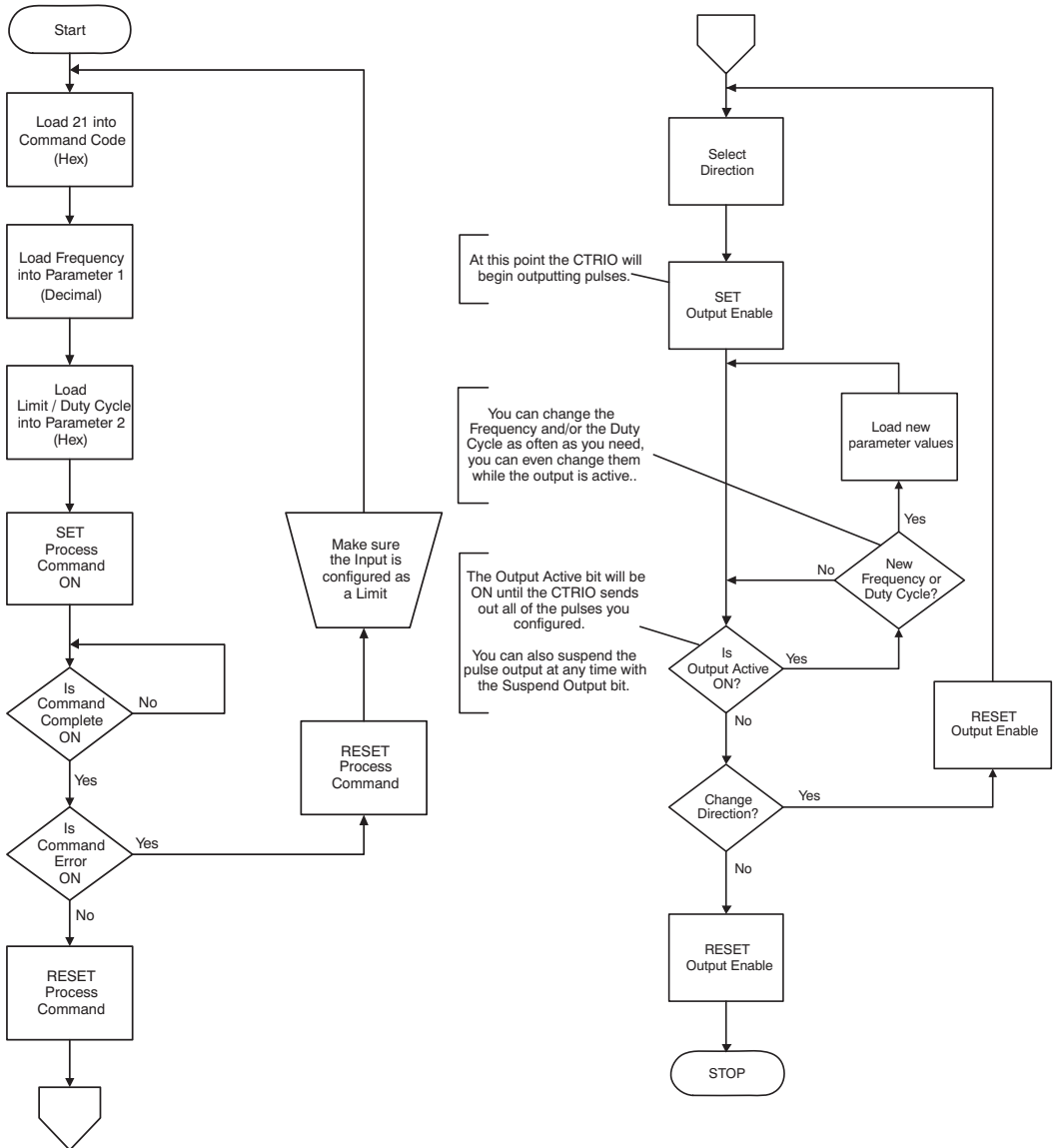

Run at Velocity on CTRIO Y0 & Y1 until Discrete Input Limit

Steps	Name	PLC Control Outputs Base Addr = V2030 (Bit-of-Word)	PLC Status Inputs Base Addr = V2000 (Bit-of-Word)	PLC Control Outputs Base Addr = V2030 (Control Relay) D2-240	PLC Status Inputs Base Addr = V2000 (Control Relay) D2-240	Action
1	Command Code	V2040		V2040		Set to 21 Hex (Run to Limit Mode)
2	Parameter 1	V2041		V2041		Set initial run frequency (20Hz-25000Hz) decimal
3	Parameter 2	V2042		V2042		Select discrete input edge in high byte, low byte = duty cycle (1-99) Example: rising input 1D at Duty = 45%, set this parameter to 212D Hex
4	Set Direction	V2056.4		C224		Set ON or OFF for Direction of Rotation
5	Process Command	V2056.7		C227		Turn ON Command Complete status bit is returned (see step 4)
6	Command Status		V2022.7		C127	When ON, command has been accepted, clear Process Command bit (step 3)
7	Command Error		V2022.6		C126	ON if Command or Parameters are invalid
8	Enable Output	V2056.0		C220		Turn ON to start pulses
9	Output Active Status		V2022.4		C124	ON while pulsing, OFF when limit has stopped pulsing
10	Suspend Output	V2056.2		C222		Turn ON to "pause" output pulses without resetting pulse count
11	Output Suspended		V2022.2		C122	ON when out pulse train has been suspended

Run to Position Mode



NOTE: Run to Position Mode controls the pulse outputs directly from the CPU/controller program. No CTRIO Workbench Pulse Profile is required for this mode.

The Run to Position Mode command (Command = 0022Hex/BCD) allows Pulse Outputs that terminate when the specified Input Function Value position count is reached. Set Word Parameter 1 to the desired Frequency. Set Word Parameter 2 Low Byte to the Duty Cycle and the High Byte to the Compare Functions as defined below. Leaving the Duty Cycle set to 0 achieves the default (50%), otherwise it can be set in 1% increments by writing this value from 1 to 99 Hex/BCD.

Word Parameter 3 specifies the value that Input Function will compare against.

The flowchart on the following page provides the logical sequence necessary to execute a Run to Position pulse profile.

See Chapter 8 for a *DirectLOGIC* programming example that executes a Run to Position pulse profile using the bit/(D)word addressing in the table on page 6-47.

Parameter 2

Word Parameter 2 defines three elements of the Run to Position routine. Bit 12 determines if the specified position is “greater than or equal” or “less than” the current Input Function position value. Bits 9 and 8 determine which Input Function to use for the comparison. The low byte specifies the duty cycle.

Specified Position (Parameter 3) is:	Parameter 2 Bit 12	Parameter 2 Bits 9 & 8	Parameter 2 (Hex) (Duty cycle at 50%)
less than Ch1/Fn1	0	00	0000
greater than Ch1/Fn1	1	00	1000
less than Ch1/Fn2	0	01	0100
greater than Ch1/Fn2	1	01	1100
less than Ch2/Fn1	0	10	0200
greater than Ch2/Fn1	1	10	1200
less than Ch2/Fn2	0	11	0300
greater than Ch2/Fn2	1	11	1300

Comparison	Bits 15..12	Input Function	Bits 11..8
Greater Than or Equal	0001, 1Hex	Ch 1 Fn 1	0000, 0Hex
Less Than	0000, 0Hex	Ch 1 Fn 2	0001, 1Hex
		Ch 2 Fn 1	0010, 2Hex
		Ch 2 Fn 2	0011, 3Hex

Run to Position Mode Flowchart

The flowchart below provides the logical sequence necessary to execute a Run to Position Mode pulse profile.

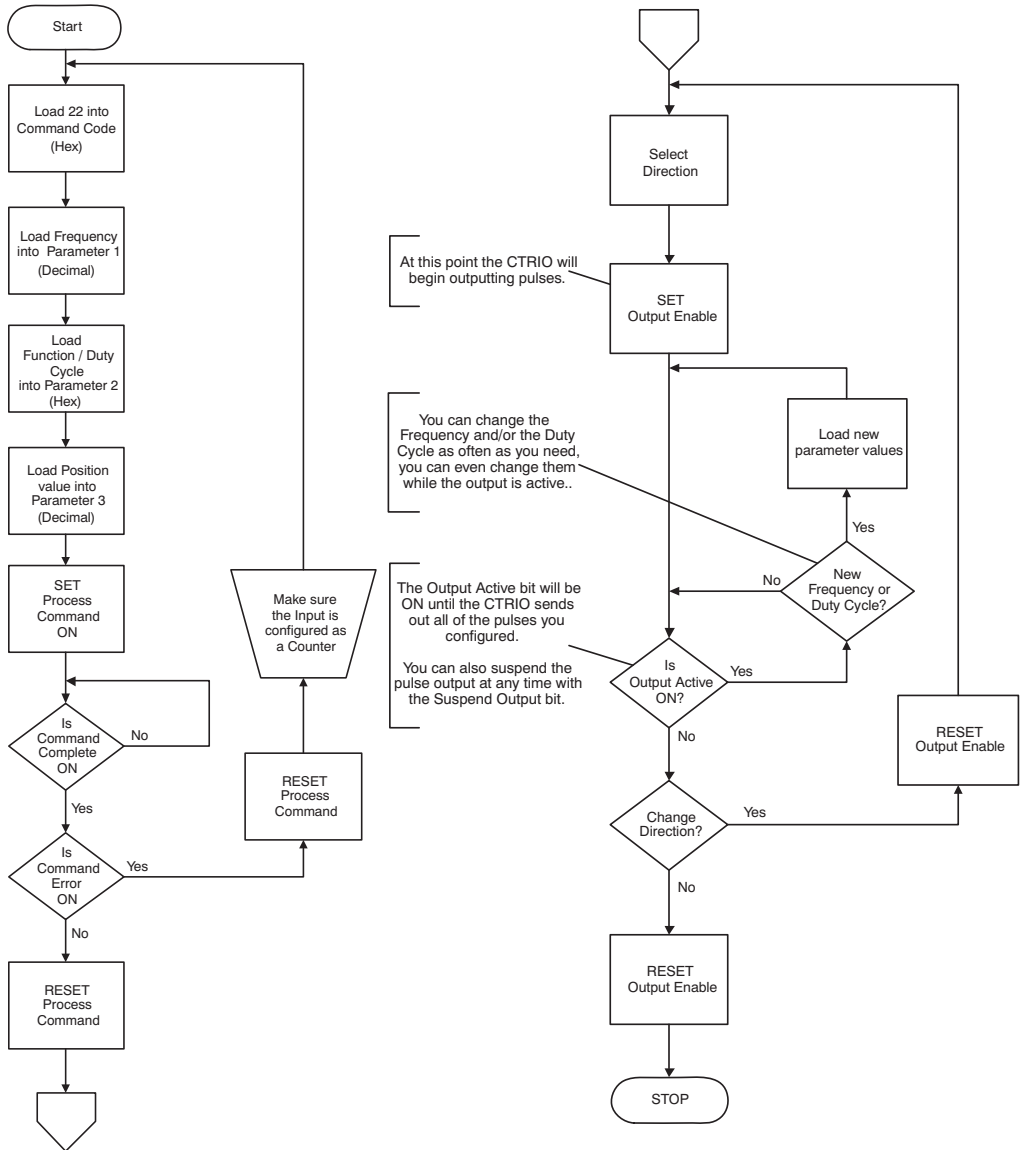

Run at Velocity on CTRIO until Input Function Value Position

Steps	Name	PLC Control Outputs Base Addr = V2030 (Bit-of-Word)	PLC Status Inputs Base Addr = V2000 (Bit-of-Word)	PLC Control Outputs Base Addr = V2030 (Control Relay) D2-240	PLC Status Inputs Base Addr = V2000 (Control Relay) D2-240	Action
1	Command Code	V2040		V2040		Set to 22 Hex (Pulse at velocity until Function Input Limit)
2	Parameter 1	V2041		V2041		Set initial run frequency (20Hz-25000Hz) decimal
3	Parameter 2	V2042		V2042		Bits 15-12: Comparison Bits 11-8: Input Function to use Low Byte:Duty cycle (1-99) (can leave 0 for 50%) Hex
4	Parameter 3	V2031 / V2030		V2031 / V2030		Specified position for Input Function DWord to compare against, decimal
5	Set Direction	V2056.4		C224		Set ON or OFF for Direction of Rotation
6	Process Command	V2056.7		C227		Turn ON Command Complete status bit is returned (see step 4)
7	Command Status		V2022.7		C127	When ON, command has been accepted, clear Process Command bit (step 3)
8	Command Error		V2022.6		C126	ON if Command or Parameters are invalid
9	Enable Output	V2056.0		C220		Turn ON to start pulses
10	Output Active Status		V2022.4		C124	ON while pulsing, OFF when position is reached
11	Suspend Output	V2056.2		C222		Turn ON to "pause" output pulses without resetting pulse count
12	Output Suspended		V2022.2		C122	ON when out pulse train has been suspended

System Functions

System Functions Commands are primarily used to read from and write to the CTRIO's internal registers. The flowcharts on the following pages provide *DirectLOGIC* and ThinknDo users the logical sequence necessary to read from and write to the CTRIO's internal registers.

The CTRIO's internal current count register can be read from or written to if the input is configured for a Counter or Quadrature Counter. Timer values are not accessible.

The CTRIO's internal current output pulse count can be read from or written to only if the pulse output is running Dynamic Velocity or Dynamic Positioning profiles.

See Chapter 8 for *DirectLOGIC* programming examples that use the RD and WT

Steps	Name	PLC Control Outputs Base Addr = V2030 (Bit-of-Word)	PLC Status Inputs Base Addr = V2000 (Bit-of-Word)	PLC Control Outputs Base Addr = V2030 (Control Relay) D2-240	PLC Status Inputs Base Addr = V2000 (Control Relay) D2-240	Action
1	Command Code	User Specified to use with RD/WT Instruction		User Specified to use with RD/WT Instruction		1 Hex: Read All Registers 2 Hex: Write All Registers 4 Hex: Write One Register 5 Hex: Write Reset Value
2	System Command Error		V2024.6		C106	ON if Command or Parameters are invalid
3	System Command Complete		V2024.7		C107	When ON, command has been accepted, clear Process Command bit
6	Process Command	V2060.7		C207		Turn ON Command Complete status bit is returned



NOTE 1: The D2-240 CPU does not support bit-of-word addressing. The status and control bits must be mapped to control relay words. An example of mapping code is shown below.

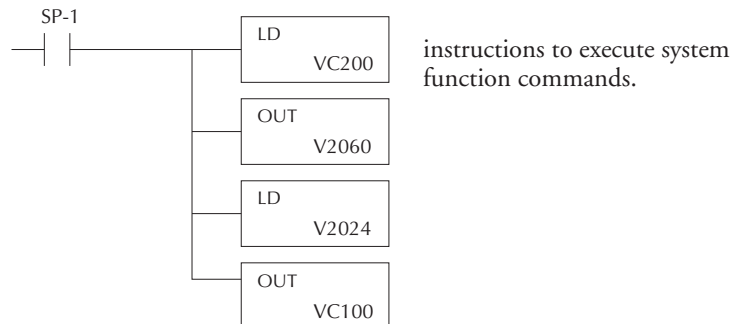

NOTE 2: For example, *DirectSOFT* uses B2020.1 in the ladder code to indicate that you are addressing the second bit of V-memory register 2020. The "B" prefix indicates bit-of-word addressing.

Reading All CTRIO's Internal Registers Flowcharts

The flowcharts below provide the logical sequence necessary to Read the CTRIO's internal registers. Reading the CTRIO's internal registers is a two-step process.

- 1) Ask the CTRIO to transfer the internal register values to its shared RAM.
- 2) Transfer the values from the CTRIO's shared RAM to the controller's memory.

DirectLOGIC Read from CTRIO

ThinknDo Read from CTRIO

6

- 1 -
This command tells the CTRIO to copy all 8 of it's internal register values (4 bytes per value) into it's shared RAM, making them accessible to the CPU.

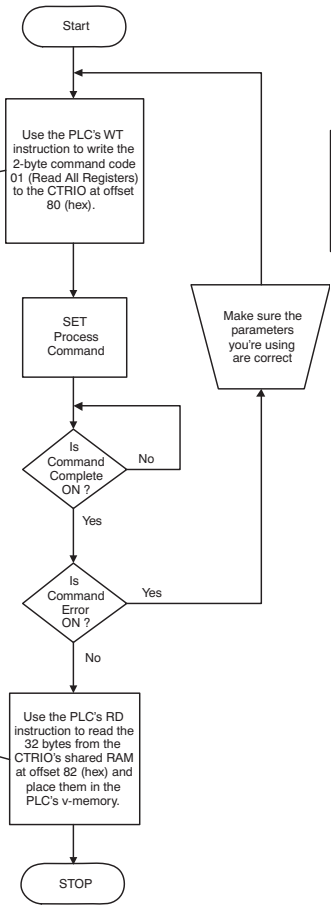

- 2 -
The 32 bytes of data make up the 8 CTRIO register values. They are arranged as follows:
Bytes 0/3 - Ch1/Fn1
Bytes 4/7 - Ch1/Fn2
Bytes 8/11 - Ch2/Fn1
Bytes 12/15 - Ch2/Fn2
Bytes 16/19 - Output 0
Bytes 20/23 - Output 1
Bytes 24/27 - Output 2
Bytes 28/31 - Output 3

- 1 -
This command tells the CTRIO to copy all 8 of it's internal register values into it's shared RAM, making them accessible.

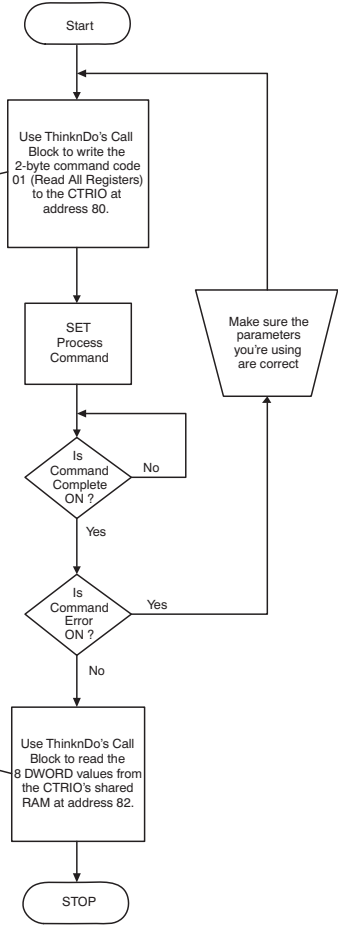

- 2 -
The 8 CTRIO register values are arranged as follows:
DWORD 0 - Ch1/Fn1
DWORD 1 - Ch1/Fn2
DWORD 2 - Ch2/Fn1
DWORD 3 - Ch2/Fn2
DWORD 4 - Output 0
DWORD 5 - Output 1
DWORD 6 - Output 2
DWORD 7 - Output 3

Writing to All CTRIO's Internal Registers Flowcharts

The flowcharts below provide the logical sequence necessary to Write to all of the CTRIO's internal registers. Writing to the CTRIO's internal registers is a two-step process.

- 1) Transfer the data values from the controller's memory to the CTRIO's shared RAM.
- 2) Ask the CTRIO to transfer these values from its shared RAM to its internal registers.

DirectLOGIC Write to CTRIO

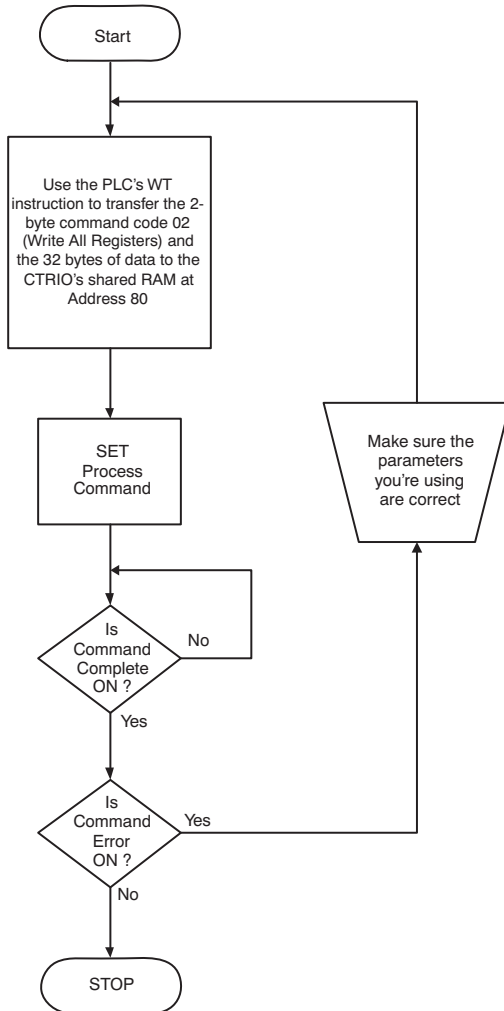

ThinknDo Write to CTRIO

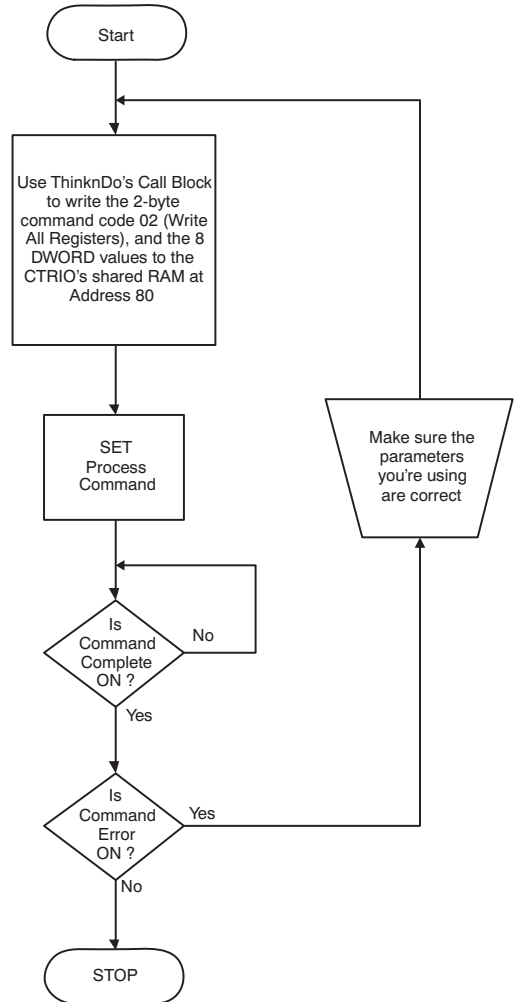

Writing to One CTRIO Internal Register Flowcharts

The flowcharts below provide the logical sequence necessary to Write to one of the CTRIO's internal registers. Writing to a CTRIO internal register is a two-step process.

- 1) Transfer the data value from the controller's memory to the CTRIO's shared RAM.
- 2) Ask the CTRIO to transfer this value from its shared RAM to its internal registers.

DirectLOGIC Write to CTRIO

ThinknDo Write to CTRIO

6

The Destination Register values are as follows:
 0 - Ch1/Fn1
 1 - Ch1/Fn2
 2 - Ch2/Fn1
 3 - Ch2/Fn2
 4 - Ouput 0
 5 - Ouput 1
 6 - Ouput 2
 7 - Ouput 3

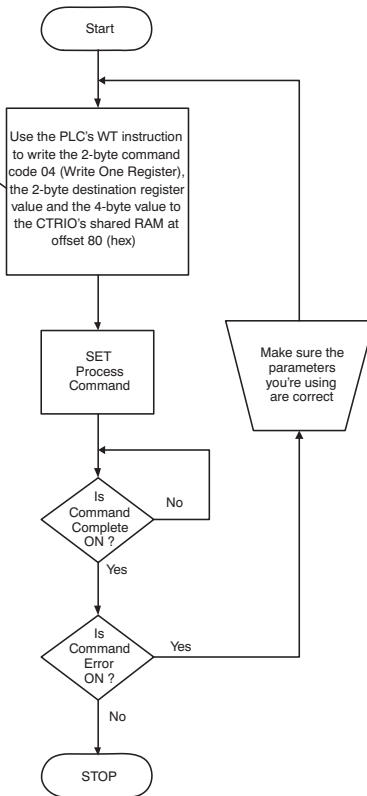

The Destination Register values are as follows:
 0 - Ch1/Fn1
 1 - Ch1/Fn2
 2 - Ch2/Fn1
 3 - Ch2/Fn2
 4 - Ouput 0
 5 - Ouput 1
 6 - Ouput 2
 7 - Ouput 3

