

Installation and Setup

In This Chapter. . . .

- Installing the H0–PSCM
 - The Profibus Network
 - Configuring the Module
-

Installing the H0-PSCM

Remove the Slot Cover

The first step in installing the option module is to remove the protective option slot cover. Remove the cover by squeezing the pinch tabs and lifting the cover off.

Installation and Setup

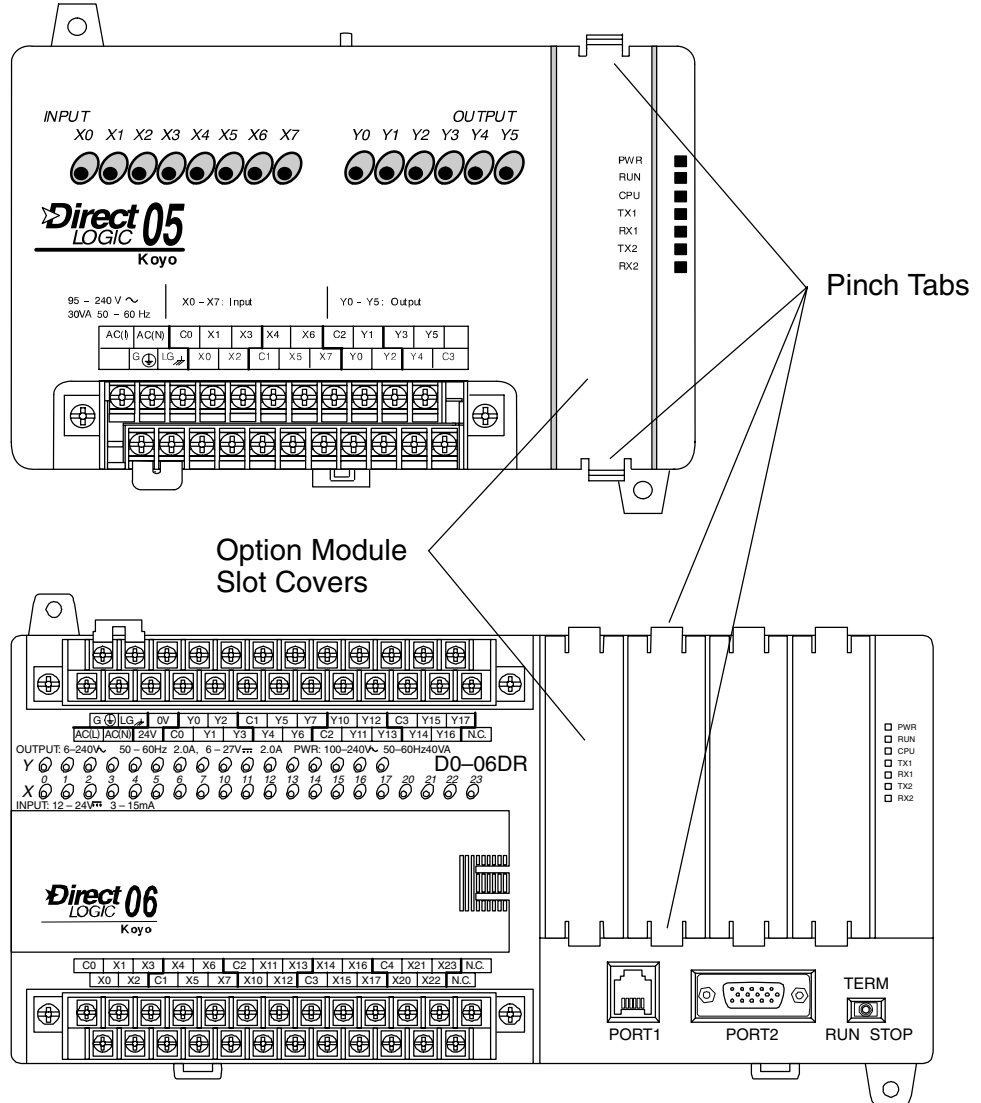

Insert the Module

Now, insert the module into the open slot. Locate the module so the printed information is oriented in the same direction as the markings on the PLC. Be careful to align the female connector on the printed circuit board of the module with the male connector on the PLC mother board. Press the module into the slot until the front of the module is flush with the front of the PLC and secure the locking tabs. Install the remaining modules in the PLC. Once the modules are in place the PLC is ready to be programmed.



WARNING: Power to the PLCs must be disconnected before inserting or removing a module. Failure to disconnect power could result in serious damage to a module, the PLC or both.

Set the Node Address

Once the H0-PSCM is installed in the option slot, set the Node Address. The Node Address rotary switches are accessed by removing the cover located to the right of Port1 and Port2 on the DL05.

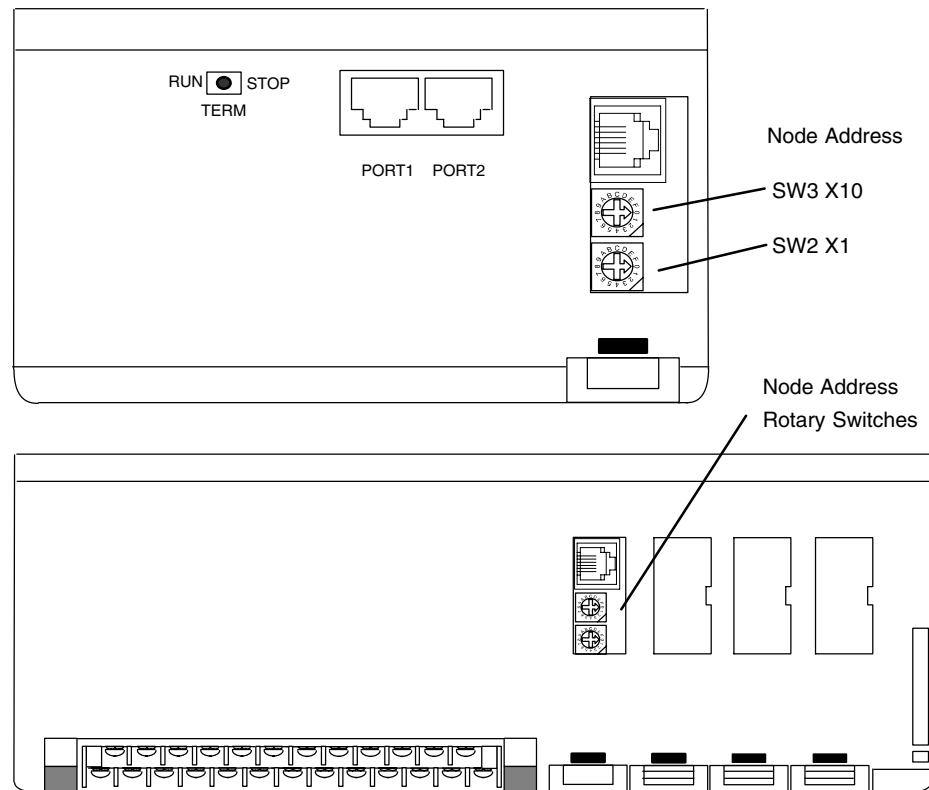

Remove the cover associated with the option slot where the H0-PSCM is installed in the DL06. Once the access cover is removed, use a small, flat, screwdriver to set the Node Address to an available address, from 3–125. Node Address 0 is normally reserved for the Profibus network master. Note that SW3 sets the tens and SW2 sets the units.

Profibus DP is usually a mono master system. Since Profibus is based on a token principle, more than one active station (masters) is allowed. The overall controlling master of the network should be node address “1”. The master should be placed at the beginning of the network. Network address “0” should be reserved for monitoring and diagnostic devices.

It is recommended that slave devices begin with address “3”. The slave devices need to be addressed in consecutive order by bus location moving away from the master.

The Profibus Network

RS-485 serial communication is most frequently used by Profibus. Twisted pair shielded copper cable with one conductor pair is the most common cable used for the Profibus network. Installation of this cable does not require expert knowledge. The bus structure permits addition and removal of stations or step-by-step commissioning of the system without interfering with the other stations. Later expansions will not effect the stations which are already in operation. It is important to follow the RS-485 installation guidelines, for 90% of the problems which occur with Profibus networks can be attributed to incorrect wiring and installation.

All devices are connected in a bus structure (line) in a Profibus network. It can be built in several segments with a segment consisting of the maximum number of stations (32) and/or the maximum length of the network. A repeater must be added if there is a need to have more than 32 stations (126 maximum). The bus is terminated by an active bus terminator at the beginning and end of each segment. See the diagram of the termination network below. Both bus terminators should be powered at all times to insure error-free operation. The bus terminator can usually be switched at the device or in the bus terminator connections.

Wiring the Controller to a PROFIBUS Network

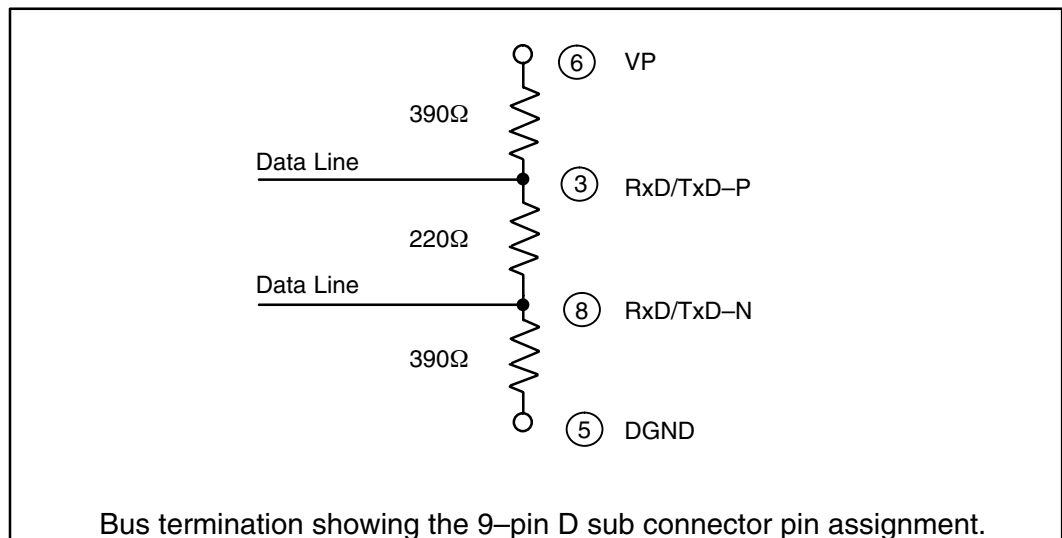

Communication speeds between 9.6 kbps and 12 Mbps are available. One unique baud rate is selected for all devices on the bus when the system is commissioned. The baud rate selected will depend upon the cable length.

The following table shows the maximum network cable lengths for the available baud rates that can be obtained with copper wire.

Baud Rate (bits per second)	Max. Segment Length	Max. Expansion
9.6k	1,000m / 3,278 feet	10,000m / 32,786 feet
19.2k	1,000m / 3,278 feet	10,000m / 32,786 feet
93.75k	1,000m / 3,278 feet	10,000m / 32,786 feet
187.5k	1,000m / 3,278 feet	10,000m / 32,786 feet
500.0k	400m / 1,311 feet	4,000m / 13,114 feet
1,500.0k	200m / 655 feet	2,000m / 6,557 feet
3,000.0k	100m / 327 feet	1,000m / 3,270 feet
6,000.0k	100m / 327 feet	1,000m / 3,270 feet
12,000.0k	100m / 327 feet	1,000m / 3,270 feet

To use baud rates greater than 1.5 Mbps, special connectors are required. The connectors have built in inductors in order to run with higher baud rates (refer to the diagram on page 2-9). Branch lines are not permitted when using baud rates greater than 1.5 Mbps. The minimum recommended cable length between two stations is 1m/3 feet.

The standard EN 50170 specifies the cable for use with Profibus. The following table specifications must be met for Profibus cables.

Cable Specification – Profibus DP	
Impedance	135 to 165 Ω / 3 to 20 MHz
Capacitance	< 30 pf / m
Resistance	< 110 Ω / km
Wire gauge	> 0.64 mm
Conductor area	> 0.34 mm ²

There are several types of Profibus cable available. The most common cable used has solid conductors for the Profibus line. Some recommended cables are: two with solid conductors, Belden Profibus 3079A and Siemens 6XV1 830 0AH10, one with flexible conductors, Bosch Comnet DP #913 548.

The Profibus network is generally connected with a shielded, twisted pair, cable. The shield must to be connected to the protective housing of the connector which is then brought to ground through the connection on the device. Care must be taken when connecting the wires to the connectors that the shield and wires are properly installed.

In many automation control systems, the I/O bus cables are the most important connections between individual components in the system. Damage to the cable or improper cable installation can lead to problems and often to a breakdown of the entire control system.

To avoid damage to the Profibus cables, install them where they will be clearly visible and separate from all other cables. This will improve EMC characteristics. Install the cables in their own cable trays or conduit separate from all A/C power wiring.

The standard Profibus cable is intended for permanent installation in buildings or in an environment which is protected from the climate. The cable should only be used in applications where there is a minimum of cable flexing and where it will not be exposed to a wet environment.

A 9-pin D-sub connector is required for connecting to Profibus networks using RS-485 for communication. The connector pin assignment and the wiring is shown in the following diagram.

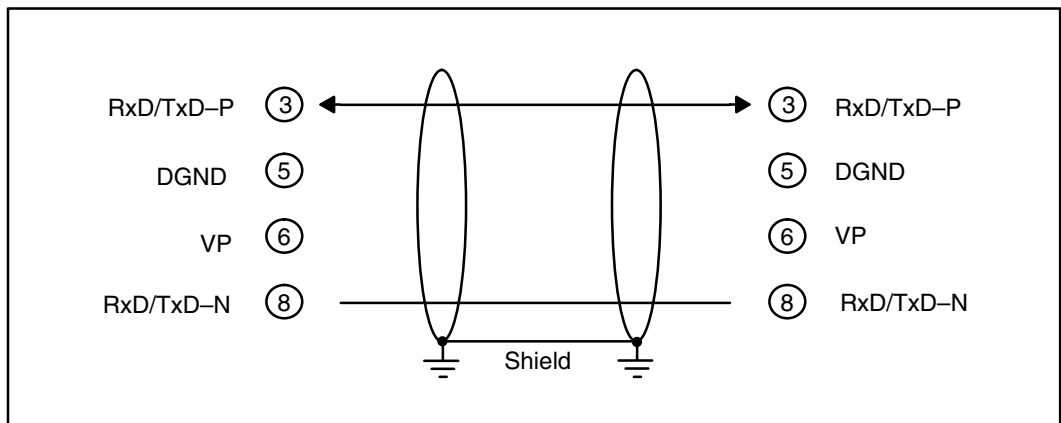

The two wires are usually color coded. Typically red and green are used. Red is used for the **B** Transmit/Receive line and Green for the **A** transmit/receive line. It is important to keep A and B line consistent throughout the network to avoid improper operation. ***This is the most common connection mistake in the field.***

It is recommended that a IP20 protective connector, such as, the Vertical Termination shown in the diagram on the next page, be used for making all terminations for the Profibus network. This is the best way for a quick and easy solution to terminating each end of your Profibus network. AutomationDirect offers two certified connectors for the Profibus Base Controller, one for a standard termination and one for a node termination.

Reverse vertical termination
AutomationDirect Part No. 103659.

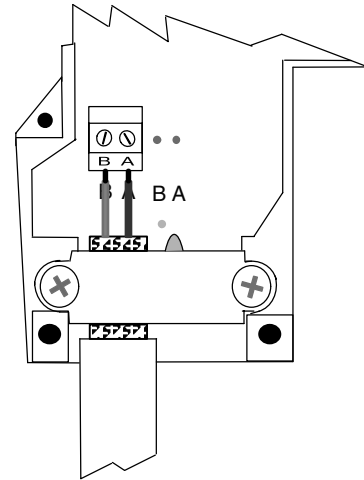

Termination showing the cable connection to points A (Red) and B (Green).

Note: The insulation has been removed exposing the shield. It is connected to ground by the metal clamp holding the cable in place.

Proper preparation of the cable is important for good Profibus network installation. When removing the cable insulation cover, make sure that the braided cable shield is not damaged. Strip the ends of the cable conductors as shown below.

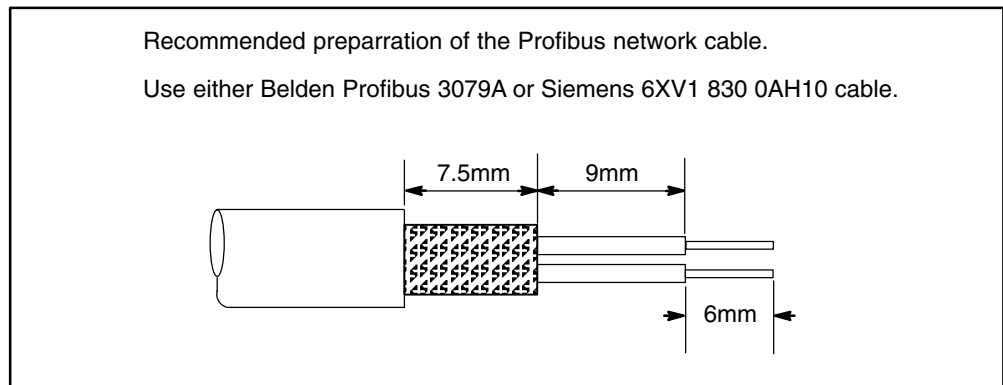

After preparing the cable, insert the green and the red conductors in the appropriate screw terminals of the bus connector.

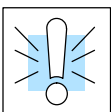

WARNING: The cable shield is not always connected to protective ground within all Profibus devices; therefore, make sure the cable shield is connected to ground before it enters the enclosure.

One important point when setting up a Profibus network is where and how to place the termination. Each Profibus peer-to-peer network, or last segment, needs to be terminated at the beginning and end of a segment (must be at the last device). The termination is usually built into the connector. Power must be supplied to the terminating resistors at the device. This means the last device needs to be powered at all times. If you have to replace the last device, the whole network could become unstable. It is preferred that the master device be installed at the beginning of the network and as a termination point.

Each segment is allowed to have a maximum of 32 stations, and a maximum of 9 segments is possible.

For installation applications where there is electromagnetic interference or to cover longer distances, fiber optic cable can be used for the Profibus field bus networks. Refer to Profibus guideline 2.022 for the specification of the Profibus fiber optic transmission method. For an overview of the fiber optic components available for Profibus, refer to a current Profibus Product Guide which can be found at the Profibus website, www.profibus.com.

Status Indicators

The H0-PSCM Profibus Slave Communication Module has four Status Indicators: STA, ERR, LINK and ACT.



Indicator	Action	Status
STA (STATUS)	ON	Powerup check passed
	OFF	Powerup check failed
ACT (ACTIVE)	ON	Connected to network
	OFF	Not connected to network or incorrect configuration
LINK	ON	Correct configuration and running
	OFF	Incorrect configuration and running
ERR (ERROR)	ON	Watchdog timer timeout

Configuring the Module

Use the Profibus configuration tool (this should come with the master unit) to configure the master and the H0-PSCM for your network. **Refer to the software Help file and/or the manual for assistance with the configuration.** Appendix D illustrates a step-by-step configuration using a SST Profibus PCI Master card.

GSD File

The actual configuration of the H0-PSCM takes place whenever the Profibus master is configured. The characteristic communication features of the H0-PSCM are defined in the form of an electronic device data sheet, GSD file. The defined file format permits the configuration system to simply read in the GSD files of the H0-PSCM and automatically use this information when configuring the bus system. The GSD file is installed in the Profibus master during the configuration of the master.

H0-PSCM Configuration

The configuration tool made available with the master controller will allow you to achieve a simple Plug and Play configuration for your Profibus network. Based on the GSD files, the network can be set up with devices from different manufacturers.

- 1. Set the module Node Address:**
Make sure that the H0-PSCM Slave module node address is set to an available node number on the Profibus network (from 3 to 125).
- 2. Configure the Profibus master:**
Configure the Profibus master with the Profibus Configuration Tool that was supplied with the master controller to configure the H0-PSCM and the DL05/06 I/O.
- 3. Add the GSD file:**
When configuring the Profibus master, add the H0-PSCM slave GSD file from the disk which came with this manual or from our web site www.automationdirect.com.
- 4. Commission the Node:**
Use the Profibus Configuration Tool to configure the master to put the system on line.
- 5. Scan the I/O:**
Use the monitor utility that comes with the configuration tool to scan the DL05/06 I/O.
- 6. View Indicators on the H0-PSCM module:**
Refer to the Status Indicators when connecting to the network.

H0-PSCM Memory Map

The H0-PSCM Profibus Slave Communications Module will transfer up to four blocks of data. The data blocks can range in size from 1 byte to 32 words and can be either input or output data. The data blocks can be mapped to real I/O within the PLC or user areas of memory.

Calculating the Power Budget for the DL06 with H0-PSCM

Managing your Power Resource

When determining which I/O modules you will be using in the H0-PSCM system, it is important to remember that there is a limited amount of power available from the power supply. A table has been provided here showing the power available from the various DL06 base units and a table showing the maximum power consumed by the H0-PSCM and each of the I/O modules supported by the H0-PSCM. Following these two tables is an example of a completed power budgeting worksheet and then a blank worksheet you can use for your own calculations.

If the I/O modules you choose exceed the maximum power available from the smaller DL06 base units, you will need to adjust the configuration.

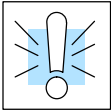

WARNING: It is *extremely* important to calculate the power budget. If you exceed the power budget, the system may operate in an unpredictable manner which may result in a risk of personal injury or equipment damage.

PSCM Power Specifications

The following table shows the amount of electrical current available at the two voltages supplied from the DL06 base unit. Use these values when calculating the power budget for you system.

The Auxiliary 24V power source mentioned in the table is available at the base terminal strip. You can connect to external devices or DL06 I/O modules that require 24VDC, but be sure not to exceed the maximum current supplied.

DL06 Power Supplied by Base Units		
Part Number	5 VDC (mA)	24 VDC (mA)
D0-06xx	<1500 mA	300 mA
	<2000 mA	200 mA
D0-06xx-D	1500 mA	none

Module Power Requirements

The chart on the next page shows the maximum amount of electrical current required to power the H0-PSCM or each I/O module. Use these values when calculating the power budget for your system.

DL06 Power Consumed by Option Cards

Part Number	5VDC	24 VDC
PBC Module		
H0-PSCM	530 mA	None
Input Modules		
D0-10ND3	35 mA	None
D0-16ND3	35 mA	None
Output Modules		
D0-10TD1	150 mA	None
D0-16TD1	200 mA	None
D0-10TD2	150 mA	None
D0-16TD2	200 mA	None
Relay Output Modules		
D0-08TR	280 mA	None
Combination Modules		
D0-07CDR	130 mA	None
D0-08CDD1	100 mA	None
Analog Modules		
F0-04AD-1	50 mA	None
F0-04AD2DA-1	100 mA	40 mA
F0-2AD2DA-2	50 mA	30 mA
F0-4AD2DA-2	100 mA	None
Specialty Modules		
H0-ECOM	25 mA	None

Power Budget Calculation Example

The following example shows how to calculate the power budget for the H0-PSCM system.

Base #	Base Unit	5 VDC (mA)	24 VDC Output (mA)
<u>1</u>			
Available Base Power	D0-06AA	<1500	300
Slot 1	D0-10TD1	150	0
Slot 2	D0-08CDD1	100	0
Slot 3	F0-2AD2DA-2	50	30
Slot 4	H0-PSCM	530	
Other			
Maximum Power Required		830	180
Remaining Power Available		1500-830= 670	300 - 170 = 120

- Using the table on the previous page, fill in the information for the base unit, the H0-PSCM, I/O modules, and any other devices that will use system power including devices that use the 24 VDC output.
- Add the current columns starting with the row for Slot 0 and working your way down to the "Other" category. Put the total in the row labeled "Maximum power required".
- Subtract the row labeled "Maximum power required" from the row labeled "Available Base Power". Place the difference in the row labeled "Remaining Power Available".
- If "Maximum Power Required" is greater than "Available Base Power" in either of the two columns, the power budget will be exceeded. It will be unsafe to use this configuration, and you will need to restructure your I/O.

Power Budget Calculation Worksheet

This blank chart is provided for you to copy and use in your power budget calculations.

Base #	Module Type	5 VDC (mA)	Auxiliary Power Source 24 VDC Output (mA)
<u>0</u>			
Available Base Power			
CPU Slot			
Slot 0			
Slot 1			
Slot 2			
Slot 3			
Slot 4			
Slot 5			
Slot 6			
Slot 7			
Other			
Total Power Required			
Remaining Power Available			

1. Using the table on the previous page, fill in the information for the base power supply, the H0-PSCM, I/O modules, and any other devices that will use system power including devices that use the 24 VDC output.
2. Add the current columns starting with the row for Slot 0 and working your way down to the "Other" category. Put the total in the row labeled "Maximum power required".
3. Subtract the row labeled "Maximum power required" from the row labeled "Available Base Power". Place the difference in the row labeled "Remaining Power Available".
4. If "Maximum Power Required" is greater than "Available Base Power" in either of the two columns, the power budget will be exceeded. It will be unsafe to use this configuration, and you will need to restructure your I/O.