

HARDWARE



In This Chapter...

Hardware Overview	2-2
Specifications	2-3
Dimensional Drawings	2-4
Installation	2-5
Mounting	2-5
Wiring	2-6
Operation	2-7
Front Panel Indicators	2-8
Recovery Mode	2-8

Introduction

The Purpose of This User's Manual

Thank you for purchasing our Stride® MQTT Gateway for your Industrial Internet of Things (IIoT) data logging. This manual describes our MQTT Gateway, its specifications and included components, and provides you with important information for installation, connectivity and setup.

Technical Support

We strive to make our manuals the best in the industry. We rely on your feedback to let us know if we are reaching our goal. If you cannot find the solution to your particular application, or, if for any reason you need technical assistance, please call us at:

770-844-4200

Our technical support group will work with you to answer your questions. They are available Monday through Friday from 9:00 a.m. to 6:00 p.m. Eastern Time. We also encourage you to visit our web site where you can find technical and non-technical information about our products and our company.

<https://www.AutomationDirect.com>

If you have a comment, question or suggestion about any of our products, services, or manuals, please let us know.

Conventions Used



*When you see the “notepad” icon in the left-hand margin, the paragraph to its immediate right will be a special note. The word **NOTE**: in boldface will mark the beginning of the text.*



*When you see the “exclamation mark” icon in the left-hand margin, the paragraph to its immediate right will be a warning or a caution. This information could prevent injury, loss of property, or even death (in extreme cases). The words **WARNING** or **CAUTION**: in boldface will mark the beginning of the text.*

Hardware Overview

The Stride MQTT Gateway is an industrial device specifically designed to implement an Industrial Internet of Things (IIoT) data collection system. It allows bidirectional communication between Modbus field equipment and an MQTT broker. It provides a Modbus RTU master interface on RS-485 and Modbus TCP over Ethernet. Variables can be read from Modbus slave devices on change or at fixed time intervals and are sent to the MQTT broker with optional SSL/TLS client certificate authentication.

The Wi-Fi model (Part No. SGW-MQ1611-WF) uses 802.11 a/b/g/n/ac in 2400MHz or 5500MHz bands.

Setup of the device is through a built-in web interface. The MQTT message structure can be configured to better adapt to different MQTT brokers (e.g., Amazon AWS, IBM Watson IoT, Mosquitto, etc.). It is possible to remotely update the firmware through the web interface.

The gateway has a low-profile format, suitable for DIN rail mounting inside industrial electrical cabinets. The full galvanic isolation ensures a good protection against interference present in industrial environments. A dedicated hardware Watchdog manages the automatic reset of the device. Signaling LEDs allow an immediate diagnosis of device operation.



SAFETY NOTICE: The Stride MQTT Gateway allows the user to connect to remote industrial controls equipment. The remote user may operate and monitor the local control system and affect the function and control of the application just as the local operator controls it. Proper Control, Security and Safety Procedures should be considered and implemented when writing data to a remote device or system.

Specifications

Stride MQTT Gateway Models			
Part Number	Ethernet	RS-485	WiFi
SGW-MQ1611	✓	✓	
SGW-MQ1611-WF	✓	✓	✓

RS-485 Specifications	
Connector	Removable screw terminals, 5.08 mm pitch
Baud rate	Up to 115.2 kbps
Parity	Even, odd or none
Stop bit	1 or 2
Number of Serial Devices	32 max.
Switching Time TX/RX (RS-485)	150µs
Termination Resistance	120Ω

Ethernet Specifications	
Connector	RJ-45
Ethernet Port Speed	10/100Mbps auto-detected
Protocol	MQTT, Modbus TCP
Simultaneous Ethernet Connections	8

WiFi Specifications (Model SGW-MQ1611-WF Only)	
WiFi Standards	802.11 a/b/g/n/ac
Frequency Bands	2400MHz / 5500MHz
Antenna	Internal

Network Ports	
Web User Interface	80
Modbus	502 (default, software configurable)
MQTT	Software configurable, determined by MQTT Broker

Electrical Specifications	
Power Supply Connector	Removable screw terminals, 5.08 mm pitch
Input Voltage Range	10–30VDC
Current Consumption	max 300mA @ 24VDC
Isolation	
Ethernet / RS-485	1500VAC, 50Hz, 1 min.
Ethernet / Power Supply	1000VAC, 50Hz, 1 min.
Power Supply / RS-485	1500VAC, 50Hz, 1 min.
Reverse Polarity Protection	Yes

Mechanical Specifications	
Material	Self-extinguishing plastic
Mounting	DIN rail (EN50022 and EN50035)
Weight	Approximately 200g

Environmental Specifications	
Operating Temperature	0°C to +60°C [32°F to +140°F]
Storage Temperature	-20°C to +70°C [-4°F to +158°F]
Humidity	0–90%, noncondensing
Maximum Altitude	2000m
IP Rating	IP20
Installation	Indoor
Category of Installation	II
Pollution Degree	2
EMC	
Immunity	EN61000-6-2
Emission	EN61000-6-4
Agency Approvals	CE, FCC, RoHS



RoHS



RoHS Compliant

Dimensional Drawings

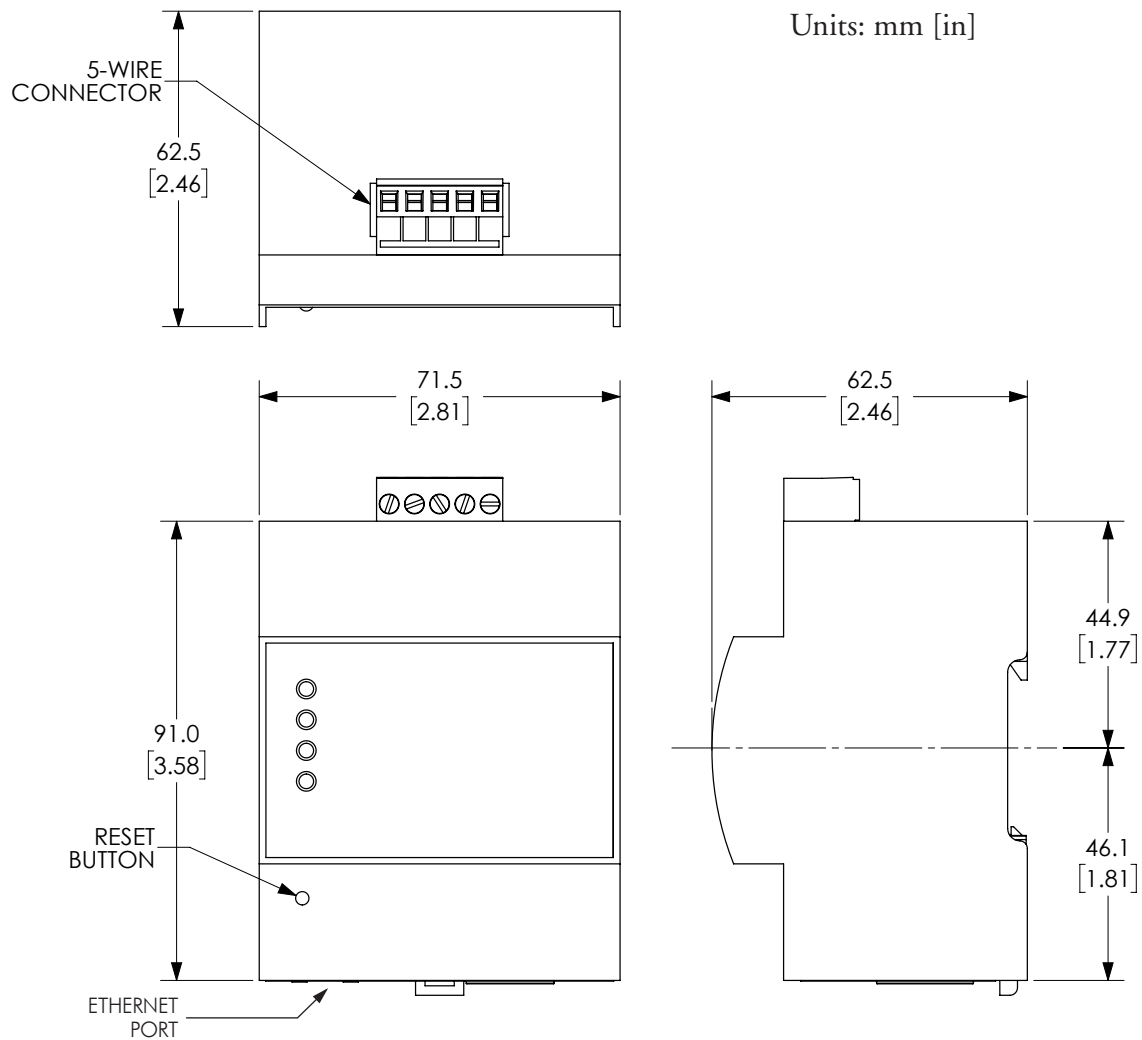

Installation

Mounting

The Stride MQTT Gateway may be used indoors only.

It is designed to be mounted in a vertical position on DIN rail and cooled using natural convection. For proper cooling, you must provide clearance of at least 5mm [0.2 inches] between MQTT Gateway modules and at least 10mm [0.4 inches] between MQTT Gateway modules and power supplies or other devices.

Make sure that sufficient air flow is provided for the gateway. Avoid placing raceways or other objects where airflow could be obstructed. Avoid mounting the gateway above equipment that generates heat; ideally locate the gateway in the lower part of the panel.

Install the gateway in a place without vibrations.

To mount the gateway:

1. Hook the top of the mounting bracket onto the DIN rail.
2. Press the bottom of the gateway inward until it clicks onto the DIN rail.

To remove the gateway:

- A. Pull downward on the mounting clip release.
- B. Swing the bottom of the gateway outward.
- C. Lift the gateway off the DIN rail.

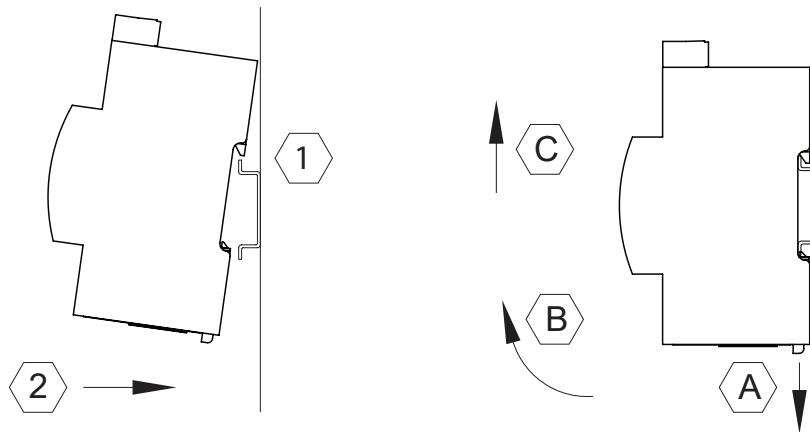

NOTE: Installation of the SGW-MQ1611-WF model in a metal cabinet is not recommended, as the cabinet may block the Wi-Fi signal.

Wiring

Wiring Guidelines



WARNING: To minimize the risk of potential safety problems, you should follow all applicable local and national codes that regulate the installation and operation of your equipment. These codes vary from area to area and it is your responsibility to determine which codes should be followed, and to verify that the equipment, installation, and operation are in compliance with the latest revision of these codes.

Equipment damage or serious injury to personnel can result from the failure to follow all applicable codes and standards. We do not guarantee the products described in this publication are suitable for your particular application, nor do we assume any responsibility for your product design, installation, or operation.

If you have any questions concerning the installation or operation of this equipment, or if you need additional information, please call technical support at 1-800-633-0405 or 770-844-4200.

This publication is based on information that was available at the time it was written. At AutomationDirect.com® we constantly strive to improve our products and services, so we reserve the right to make changes to the products and/or publications at any time without notice and without obligation. This publication may also discuss features that may not be available in certain revisions of the product.

Proper grounding and wiring of all electrical equipment is important to help ensure the optimum operation of the Stride MQTT Gateway and to provide additional electrical noise protection for your application.



WARNING: Do not terminate communication leads while the plug-in connector is connected to a powered device.

Wiring Connections

The Stride MQTT Gateway comes with a female 5-pin plug-in connector for its power and RS-485 connection.

The gateway can be powered from the same 12 to 24 VDC source that is used to power your other devices. Recommended DC power supplies are AutomationDirect.com part number PSL-12-010 or PSL-24-010.

The device uses a 2-wire RS-485 interface. It has an internal terminating resistor, so this device must be at the end of the communications daisy-chain.

Avoid routing signal cables near power cables (motors, induction ovens, inverters, etc.), and use shielded cable to connect signals. We recommend AutomationDirect Part #L19954-1 or equivalent data cable to connect RS-485 serial devices.

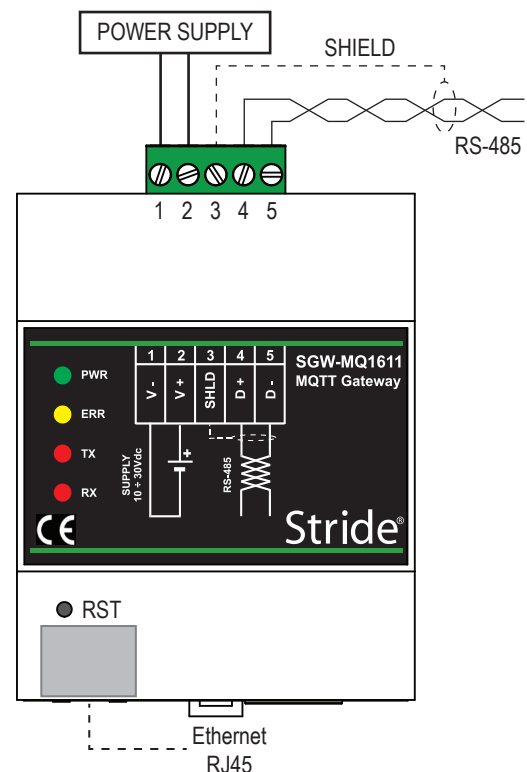

Wiring Connections			
Pin		Description	Notes
1	V-	Power Supply	10–30VDC, 300mA @ 24VDC
2	V+		
3	SHIELD	RS-485 Shield	
4	D+	RS-485 Data	Connection to one or more Modbus RTU servers
5	D-		
RJ45		Ethernet 10/100Base-T	Connection to MQTT broker and one or more Modbus TCP or Modbus RTU over TCP servers
USB (x2)			Future Use

Terminal Connector Wiring Specifications	
Wire Size	0.8–2.1 mm ² 14–18 AWG
Torque	0.5 N·m
Stripping Length	5mm maximum

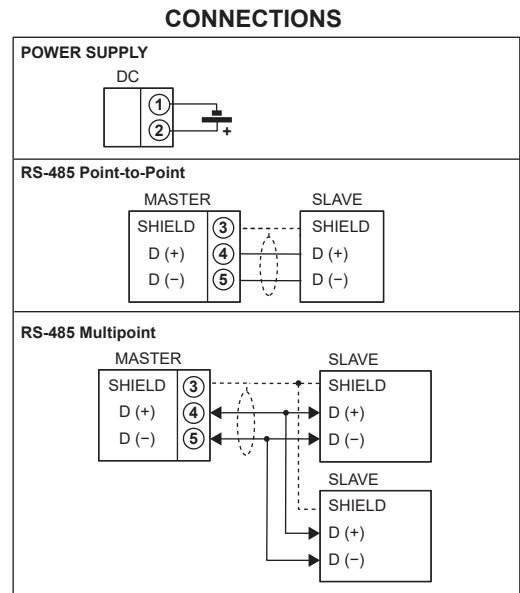

LEDs on the top surface indicate:

- * red, active internal power; green, internal memory activity

Operation

Configuration and operation of the STRIDE MQTT Gateway is primarily conducted using the device's web interface, as discussed in Chapter 2. The hardware indicators and controls are described here.

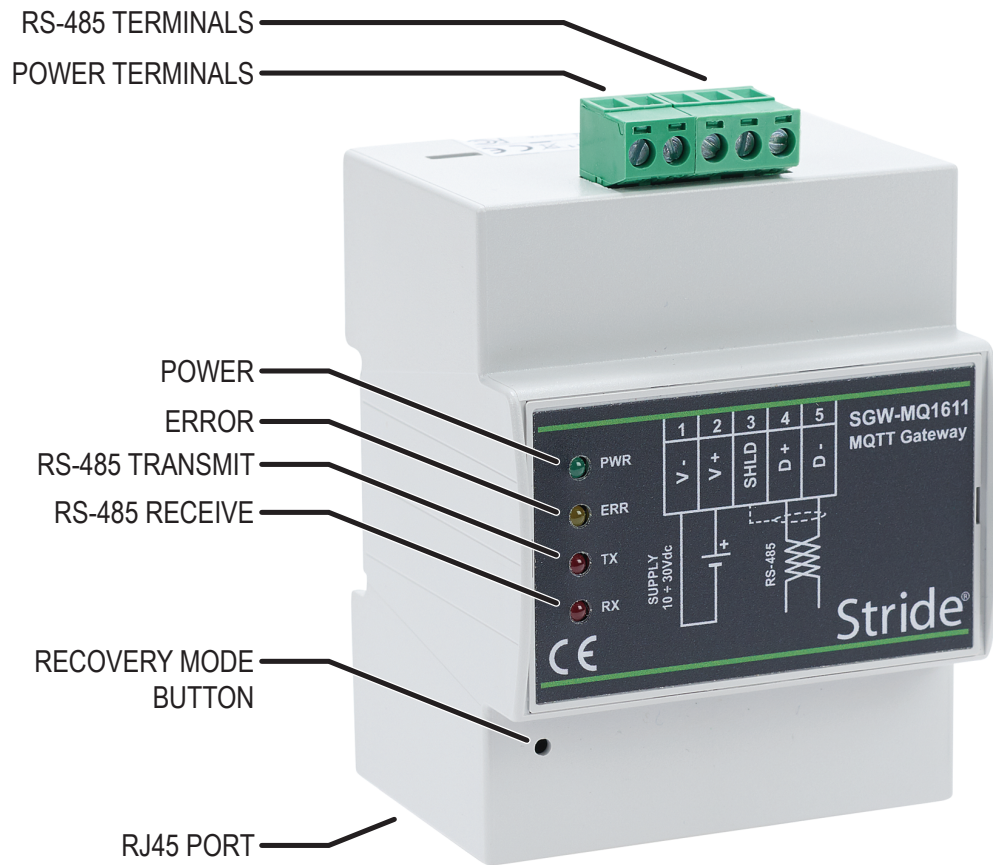

Front Panel Indicators

The Stride MQTT Gateway has four status LEDs, as shown below.

Front Panel LEDs			
LED	Color	State	Description
PWR	GREEN	ON	Device powered
		OFF	Device unpowered
ERR	YELLOW	OFF	No error
		BLINK SLOW-FAST-FAST-FAST	Boot (about 60 sec., few minutes for the first boot)
		BLINK SLOW	Communications error (Modbus, MQTT, etc.)
		BLINK FAST	Watchdog restart
TX	RED	BLINK	Data transmitted over RS-485
		OFF	No data over RS-485
RX	RED	BLINK	Data received over RS-485
		OFF	No data over RS-485



NOTE: LEDs on the top surface indicate: RED = active internal power; GREEN = internal memory activity.

Recovery Mode

The device can be booted into a Recovery Mode to reset portions of the configuration to default or to perform system maintenance and firmware updates.

To enter Recovery Mode, press and hold the recessed reset button on the front of the gateway while applying power. Continue to hold the reset button until the ERR light stops blinking (about 5 seconds after applying power). The gateway will start in Recovery Mode, using the default Ethernet configuration:

- IP address = 192.168.1.100

Details of the features available in recovery mode are discussed in Chapter 2.