

Applying Ladder Logic

General Concepts

Memory Mapping

On Page 1 of this manual, we introduced you to the basic concept of memory mapping. The OP-1124 uses memory mapping in order to link itself to a PLC. Memory mapping is a technique that maps the memory of the OP-1124 into the memory of the PLC. During initial configuration, you indicate where in the PLC memory you want to start the mapping process (See Step 7B on Page 16). By knowing where the data of the specific panel is mapped, this data can be moved, changed or monitored using ladder logic.

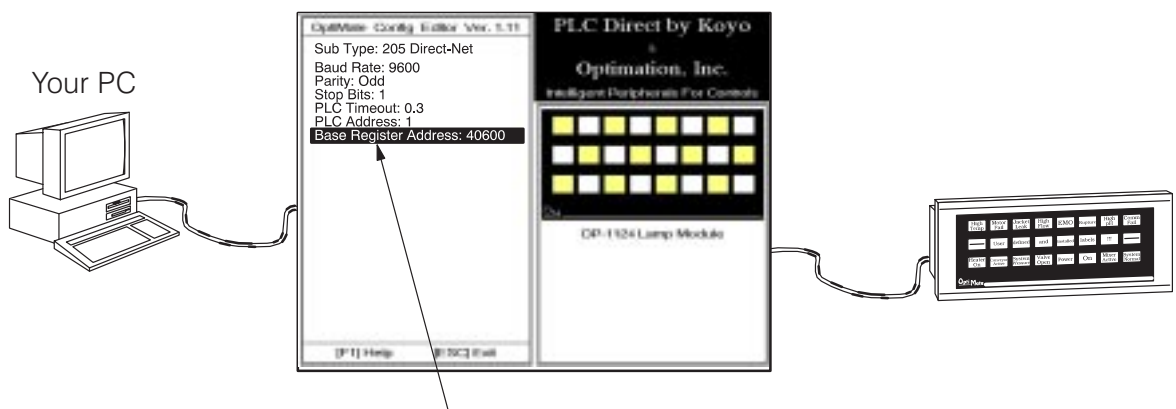

During configuration, you determine the starting address for the memory mapping process.

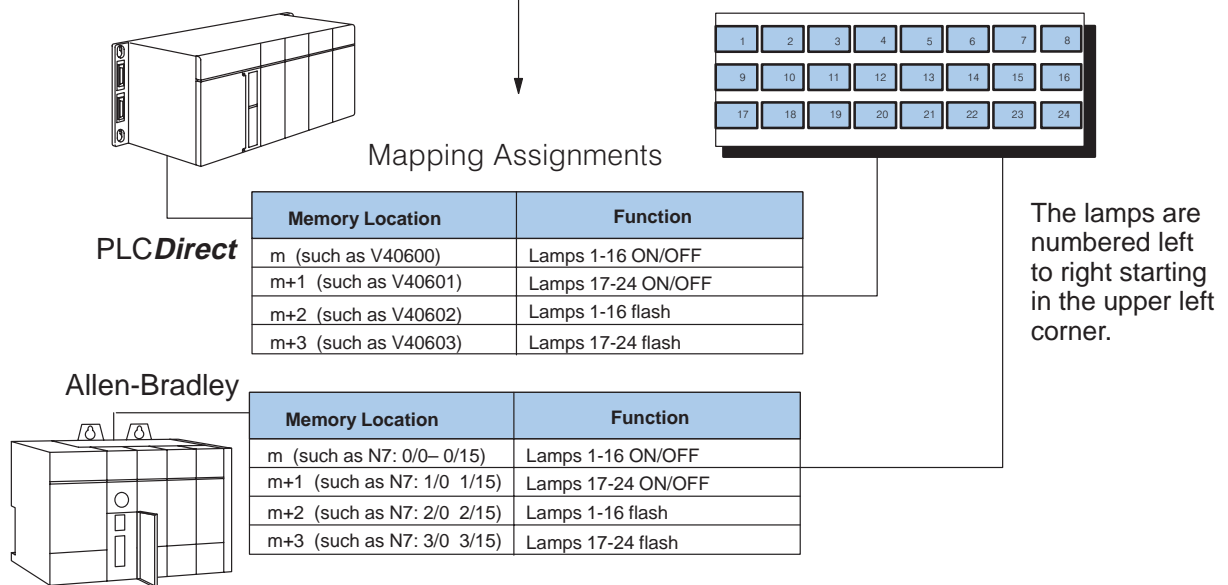

Addressing Conventions

Before we jump into ladder logic programming, let's take a moment to review and compare the addressing conventions used by PLC**Direct** and Allen-Bradley.

PLCDirect** Memory**—A typical address within a PLC**Direct** programmable controller is Vxxxx (such as V40600 for the DL205,DL350 or DL405 families) or Rxxx (such as R16 for the DL330/340 family). The V-memory in the DL205 and DL405 is divided into 16-bit boundaries, and the R-memory in the DL330/340 is divided into 8-bit boundaries. Refer to your individual User Manuals for complete memory information. The two diagrams below show you how the lamps of the OP-1124 could be mapped during configuration. In this example, we have arbitrarily chosen V40600 and R16 as starting boundaries to map the lamps ON/OFF function, but it could actually be any available user or internal relay memory areas as long as they are consecutive:

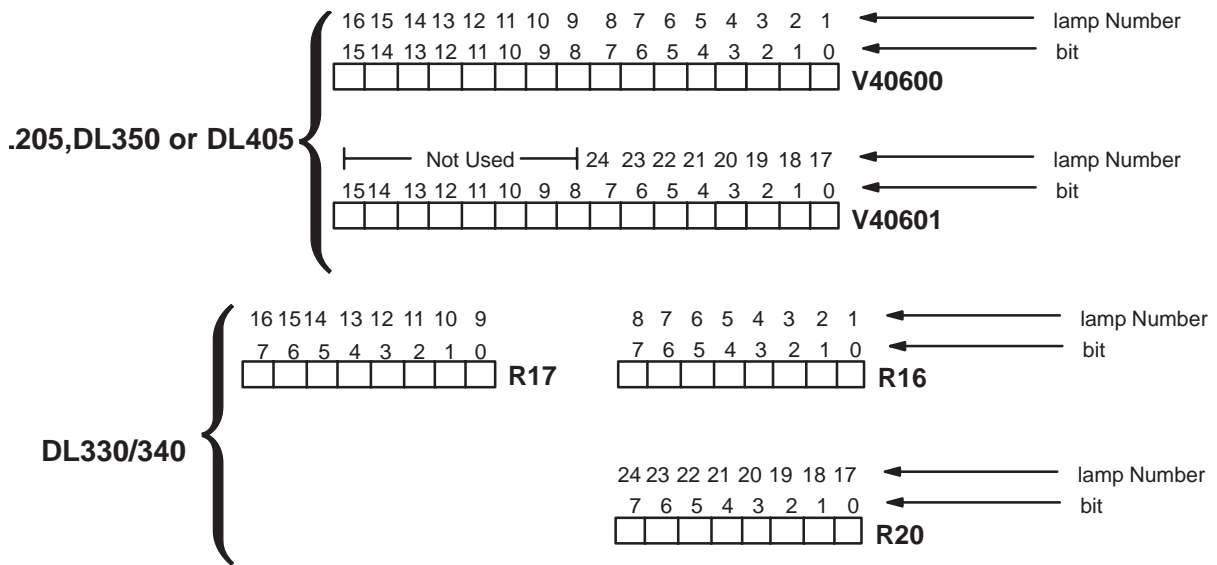

Allen-Bradley Memory—A typical address for Allen-Bradley might be N7:0/0 or N27:0/0. The OP-1124 will allow you to define your starting address for mapping purposes using either Allen-Bradley's integer (N7) file type or user-defined integer file types (N9–N255). *If you plan to use an integer file between N9 and N255, you must define these in the Allen-Bradley memory map before configuring the panel.* Below we have shown you how 16-bit integer files could be used to control the ON/OFF function of the individual lamps.

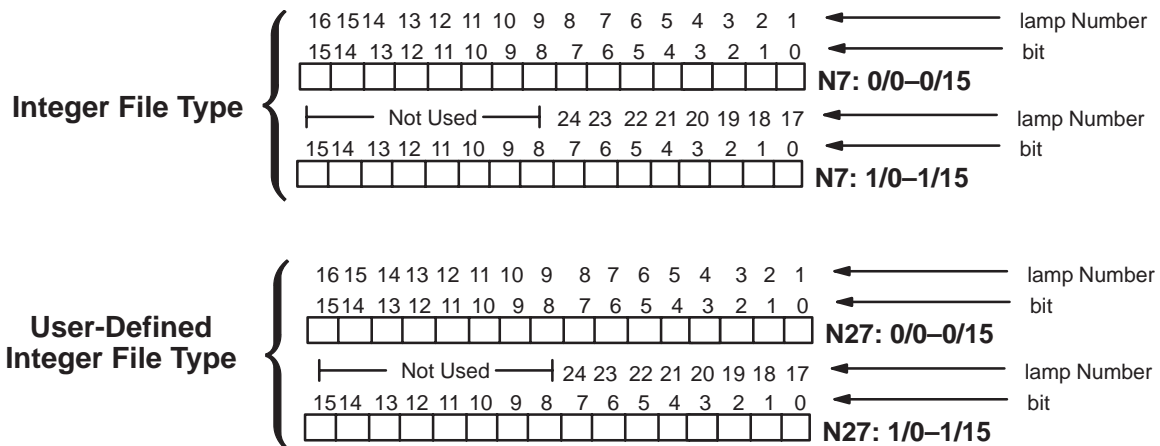

Controlling Lamps with a PLCDirect PLC

PLCDirect Internal Relays Controlling a Single Lamp

When you configure the OP1124, you must choose a base address in the CPU. You can choose any available user memory or control relay memory address. Programming is much easier for the OP-1124 if you choose “control relay memory”. We will show you both the “user memory” and “internal control relay” methods, and then let you choose which method suits your application. Refer to the PLC User Manual for a listing of the total number of internal control relays and their memory locations. The control relays of the DL205 and DL405 families start at V40600 and the control relays of the DL330/340 family start at R16. In the examples below, we have chosen V40600 as the starting address for either a DL205,DL350 or DL405. We have chosen R16 as our starting address for the DL330/340. Notice that the internal control relays are numbered in octal and not decimal.

Example showing how to turn ON Lamp No. 4 with a PLCDirect PLC.

DL205,DL350 or DL405 Families

Example Memory Locations	Function
V40600 (C0 to C17)	Lamps 1-16 ON/OFF
V40601 (C20 to C37)	Lamps 17-24 ON/OFF
V40602 (C40 to C57)	Lamps 1-16 flash
V40603 (C60 to C77)	Lamps 17-24 flash

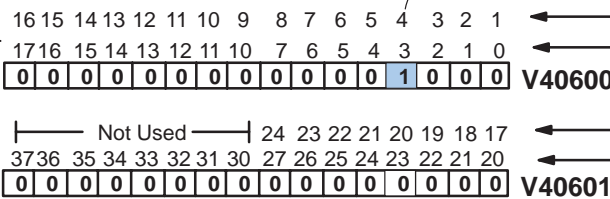
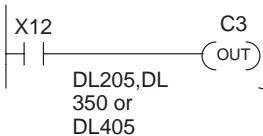
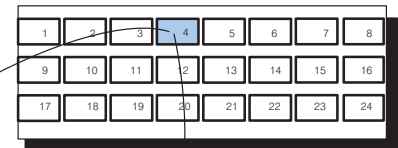

DL330/340 Family

Example Memory Locations	Function
R16 (C160 to C167)	Lamps 1-8 ON/OFF
R17 (C170 to C177)	Lamps 9–16 ON/OFF
R20 (C200 to C207)	Lamps 17–24 ON/OFF
R21 (C210 to C217)	Not Used
R22 (C220 to C227)	Lamps 1–8 flash
R23 (C230 to C237)	Lamps 9–16 flash
R24 (C240 to C247)	Lamps 17–24 flash

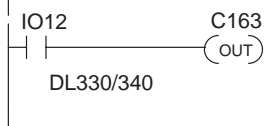

Note: To determine the control relay number, use the register number as the first two digits and the bit number as the last digit. For example, Bit 3 of R16 is referenced as C163.

**PLCDirect
Internal Relays
Controlling Multiple
Lamps**

You control multiple lamps just as you do individual lamps. Each lamp is controlled by an individual internal control relay. The example below shows how to control Lamps 3, 4 and 23.

DL205,DL350 or DL405 Families

Example showing how to turn ON Lamp Nos. 3, 4 and 23 with PLCDirect PLC

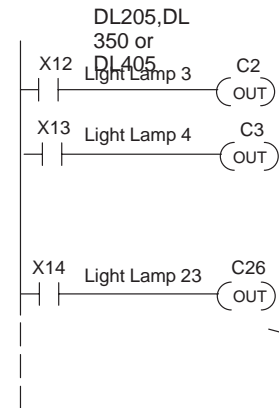

Example Memory Locations	Function
V40600 (C0 to C17)	Lamps 1-16 ON/OFF
V40601 (C20 to C37)	Lamps 17-24 ON/OFF
V40602 (C40 to C57)	Lamps 1-16 flash
V40603 (C60 to C77)	Lamps 17-24 flash

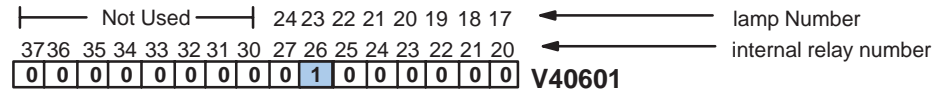
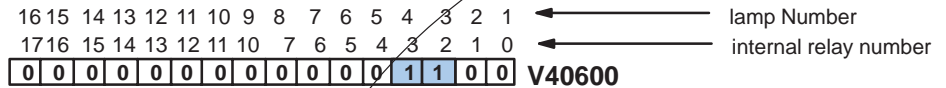

DL330/340 Family

Example Memory Locations	Function
R16 (C160 to C167)	Lamps 1-8 ON/OFF
R17 (C170 to C177)	Lamps 9-16 ON/OFF
R20 (C200 to C207)	Lamps 17-24 ON/OFF
R21 (C210 to C217)	Not Used
R22 (C220 to C227)	Lamps 1-8 / flash
R23 (C230 to C237)	Lamps 9-16 flash
R24 (C240 to C247)	Lamps 17-24 flash

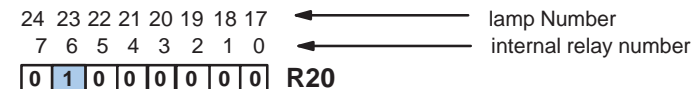
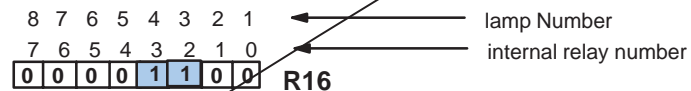
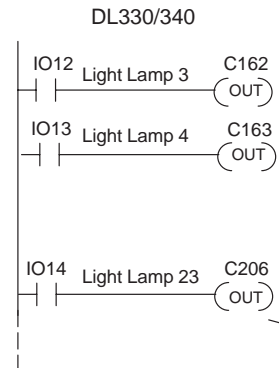
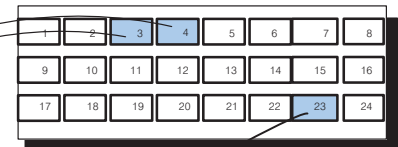

Note: To determine the control relay number, use the register number as the first two digits and the bit number as the last digit. For example, Bit 3 of R16 is referenced as C163.

PLC Direct Internal Relays Used to Add Flashing

In the examples below, we are causing Lamp 4 to flash. Notice we go through two steps to accomplish this. We first turn ON the lamp with C3 or C163 (depending on PLC used), and then we add the flashing with C43 or C213. Which control relay you use in each case, depends on which lamp you are trying to illuminate and the particular PLC you are using.

Example showing how to turn ON Lamp No. 4 and also make it flash using a PLC Direct PLC.

DL205, DL350 or DL405 Families

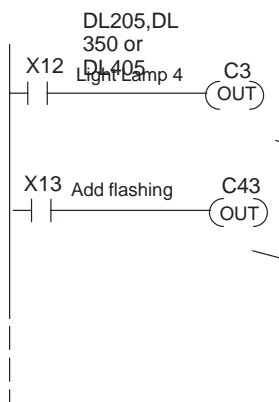

Example Memory Locations	Function
V40600 (C0 to C17)	Lamps 1-16 ON/OFF
V40601 (C20 to C37)	Lamps 17-24 ON/OFF
V40602 (C40 to C57)	Lamps 1-16 flash
V40603 (C60 to C77)	Lamps 17-24 flash

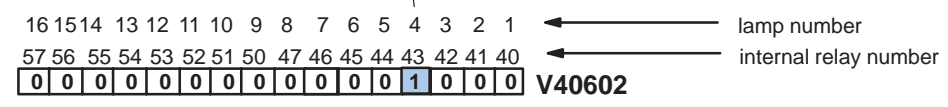
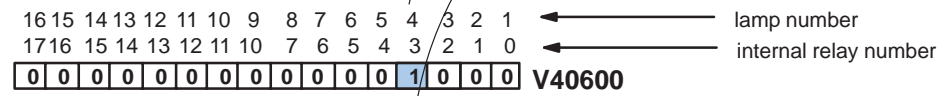
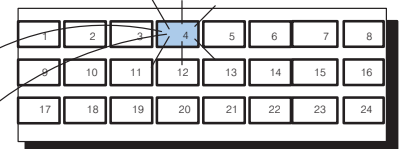

DL330/340 Family

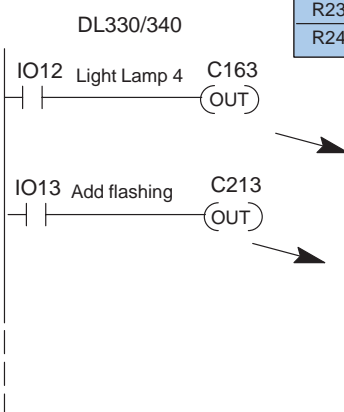

Example Memory Locations	Function
R16 (C160 to C167)	Lamps 1-8 ON/OFF
R17 (C170 to C177)	Lamps 9-16 ON/OFF
R20 (C200 to C207)	Lamps 17-24 ON/OFF
R21 (C210 to C217)	Not Used
R22 (C220 to C227)	Lamps 1-8 flash
R23 (C230 to C237)	Lamps 9-16 flash
R24 (C240 to C247)	Lamps 17-24 flash

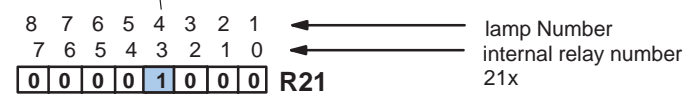
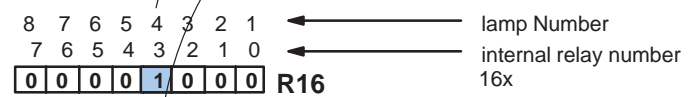
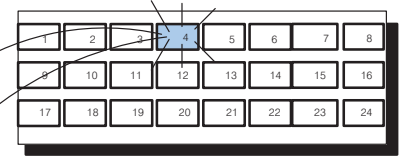

Note: To determine the control relay number, use the register number as the first two digits and the bit number as the last digit. For example, Bit 3 of R16 is referenced as C163.

PLCDirect
Controlling a Lamp
with User Memory
(DL205/DL350/DL405
Only)

If you do not want to use internal control relays, the next six pages show examples of controlling the lamps with user memory locations. In all the examples that follow, we have chosen V2000 to be our base address. The 16-bits belonging to V2000 control the ON/OFF state of the first two rows of lamps. The next three consecutive memory words control the bottom row, and the flashing feature. Notice that the hexadecimal number formed is the sum of all the weights in the 16-bit register that are set to logical 1. For example, the value 0008 hexadecimal stored at V2000 will turn ON bit 3 controlling Lamp No. 4. The ladder logic shown below demonstrates how this takes place.

DL205,DL350 or DL405 Families

Example showing how to turn ON Lamp No. 4 with a PLCDirect PLC.

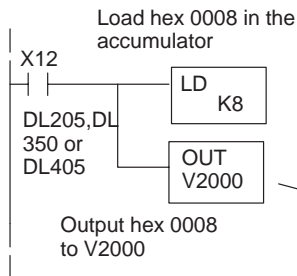

Example Memory Locations	Function
V2000	Lamps 1-16 ON/OFF
V2001	Lamps 17-24 ON/OFF
V2002	Lamps 1-16 flash
V2003	Lamps 17-24 flash

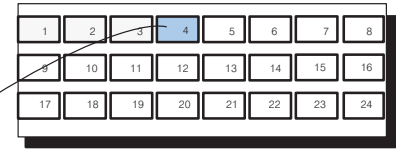

Lamp 4 turns ON

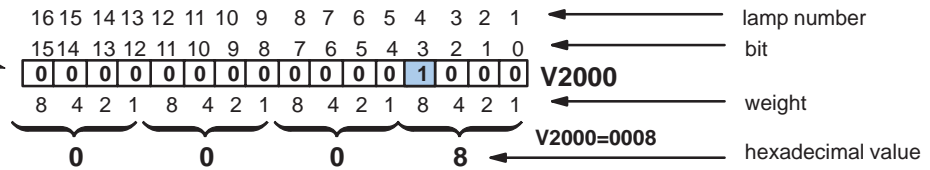

PLCDirect Controlling a Lamp with Bit-of-Word (DL250/350/450 Only)

The DL450 has the additional advantage of allowing “bit-of-word” operations. This allows you to turn on individual bits without the the 2-step process of loading hexadecimal values into an accumulator and then outputting it to memory. With the DL450, you merely use the starting number of the 16-bit memory boundary (i.e. V2000) and then use a decimal point followed by the particular number of the bit you want to turn ON. In this example, we want to turn ON bit number 3 because it controls Lamp No. 4. Remember that bits number right to left starting with 0. You can trigger this output using the usual data types or nicknames for open and closed contacts. Here we have used X12 for example.

DL250/350/450 Only

Example showing how to turn ON Lamp No. 4 with a PLCDirect DL450 PLC.

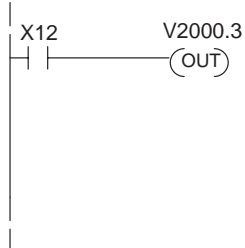

Example Memory Locations	Function
V2000	Lamps 1-16 ON/OFF
V2001	Lamps 17-24 ON/OFF
V2002	Lamps 1-16 flash
V2003	Lamps 17-24 flash

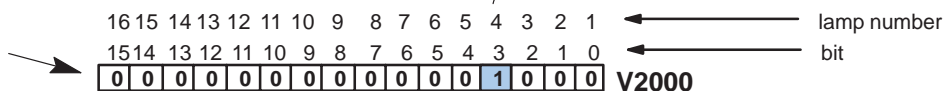
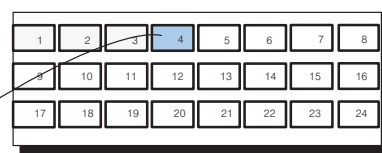

PLCDirect
Controlling Multiple
Lamps with User
Memory
(DL205/DL350/DL405
Only)

The same process is used for turning ON several lamps as for turning on one lamp. Notice that here we are using both words of memory reserved for ON/OFF control, because we are turning ON lamps in both the top row and the bottom row.

Example showing how to turn ON Lamp Nos. 3, 4 and 23 with PLCDirect PLC

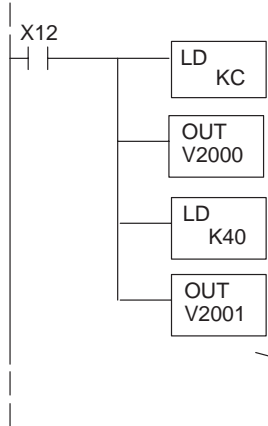

DL205,DL350 or DL405 Families

Example Memory Locations	Function
V2000	Lamps 1-16 ON/OFF
V2001	Lamps 17-24 ON/OFF
V2002	Lamps 1-16 flash
V2003	Lamps 17-24 flash

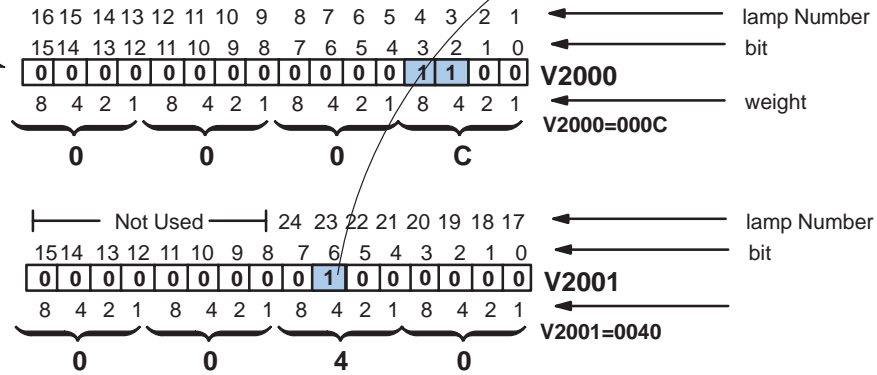
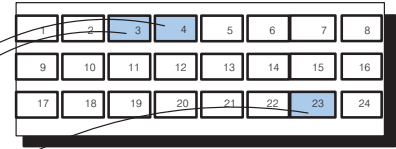

PLCDirect
Controlling Multiple
Lamps with
Bit-of-Word
(DL250/350/450 Only)

Turning ON more than one lamp when using the DL450 greatly simplifies matters. Because it allows you to use “bit-of-word” operations, you do not have to calculate a hexadecimal value that will turn on the correct bits. With the DL450, you merely use the starting number of the 16-bit memory boundary (i.e. V2000) and then use a decimal point followed by the particular number of the bit you want to turn ON. In this example, we want to turn ON bit numbers 2, and 3 of V2000; and bit number 4 of V2001 because they control Lamp Nos. 3, 4 and 23. Remember that bits number right to left starting with 0. You can trigger this output using the usual data types or nicknames for open and closed contacts. Here we have used X12 for example.

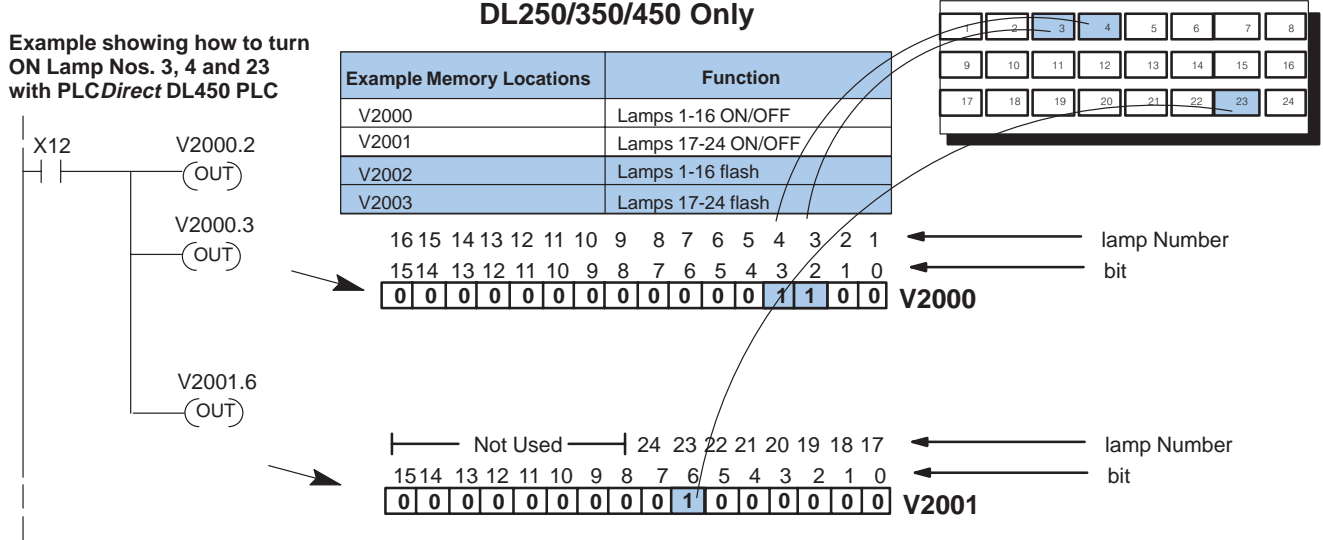

PLCDirect
Adding the Flashing
with User Memory
(DL205/DL350/DL405
Only)

Remember from our table on the previous page that bits in V2002 and V2003 control the flashing feature. Notice that you must first turn ON a lamp before you can also make it flash. In other words, in this example, it would not be enough to just turn ON bit 3 in V2002 in order to have the 4th lamp flash. You have to turn ON the bit in V2000 also.

Example showing how to turn ON Lamp No. 4 and also make it flash using a PLCDirect PLC.

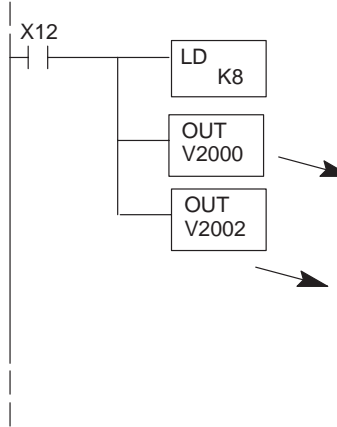

DL205,DL350 or DL405 Families

Example Memory Locations	Function
V2000	Lamps 1-16 ON/OFF
V2001	Lamps 17-24 ON/OFF
V2002	Lamps 1-16 flash
V2003	Lamps 17-24 flash

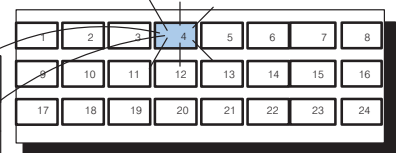

Lamp 4 turns ON and flashes

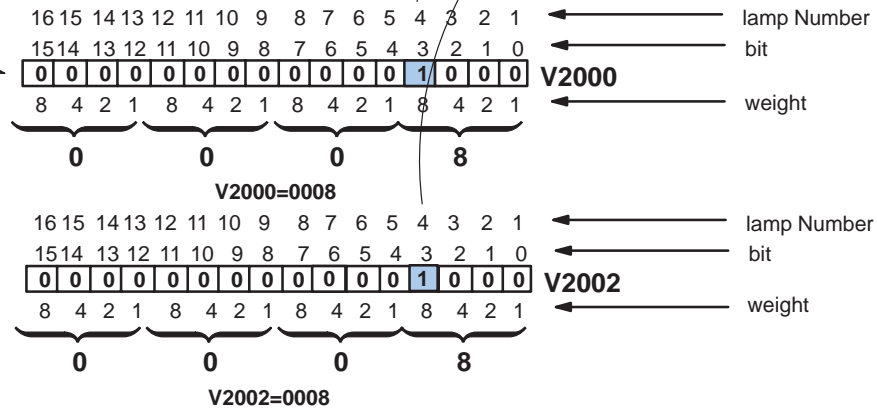

PLCDirect
Adding Flashing with
Bit-of-Word
(DL250/350/450 Only)

To add flashing when using the DL450, you can use the “bit-of-word” operation. This precludes you from having to load a hexadecimal number in the accumulator followed by an output to memory. Instead, you merely use the decimal point convention coupled with the V-memory location to designate the bit you want turned ON. In this example, we want to turn ON bit number 3 of V2000 and bit number 3 of V2002. One memory location controls turning ON the lamp, and the other controls adding the flashing feature.

Example showing how to turn ON Lamp No. 4 and also make it flash using a PLCDirect DL450 PLC.

DL250/350/450 Only

Example Memory Locations	Function
V2000	Lamps 1-16 ON/OFF
V2001	Lamps 17-24 ON/OFF
V2002	Lamps 1-16 flash
V2003	Lamps 17-24 flash

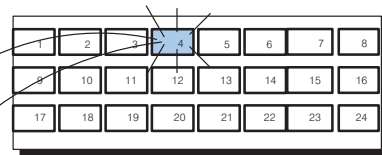

Lamp 4 turns ON and flashes

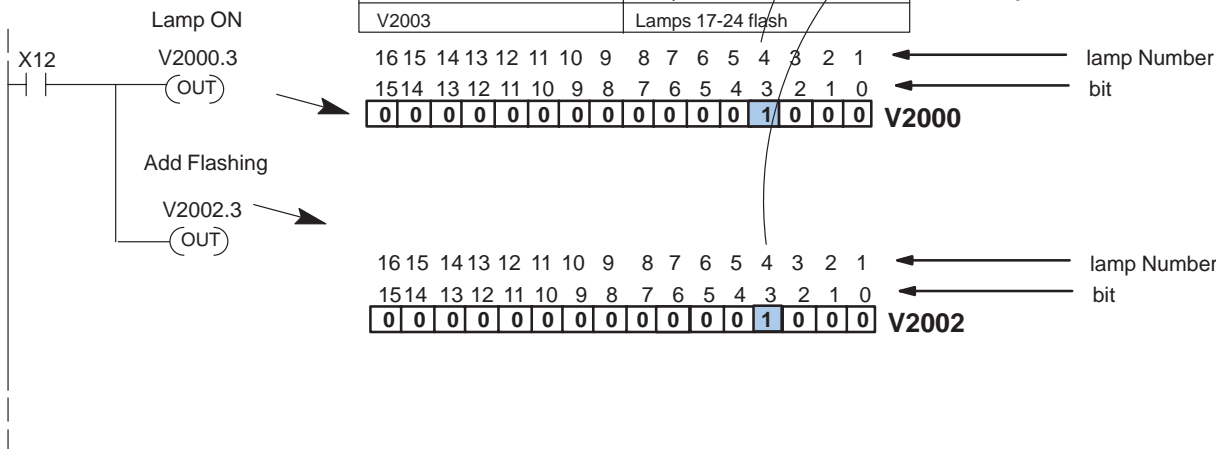

Controlling Lamps with an Allen-Bradley PLC

Allen-Bradley Example

The Allen-Bradley interface works much the same as with PLC *Direct*. Although the addressing conventions are quite different, both systems still use consecutive memory words controlling the ON/OFF and flashing of the lamps. In this Allen-Bradley example, we are using an integer file type (N7) with the starting address at 0/0.

Example showing how to turn ON Lamp No. 4 with an Allen-Bradley PLC.

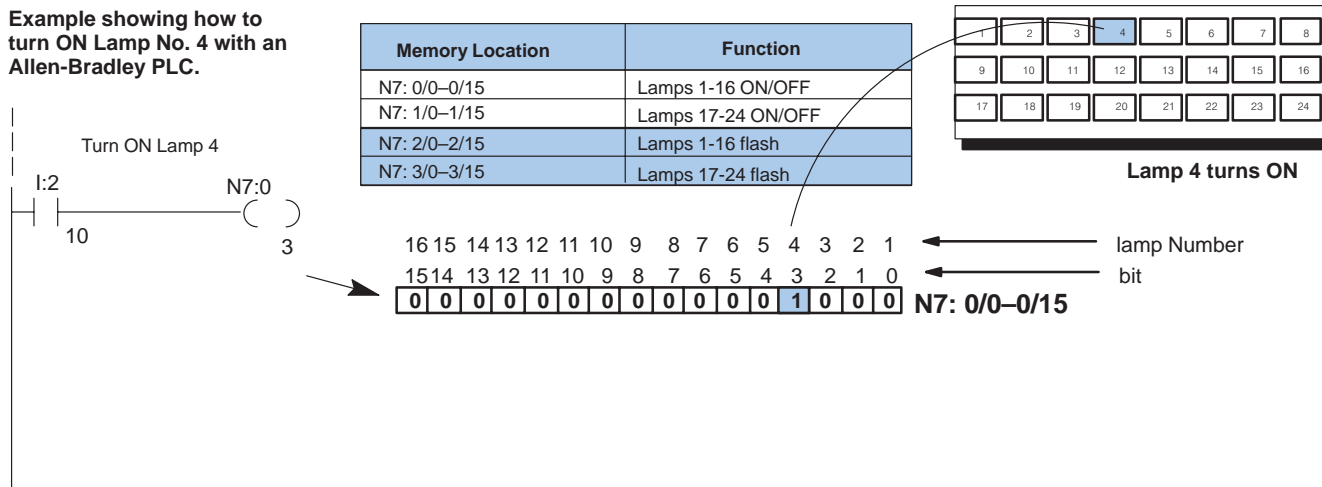

Turning ON Multiple Lamps (Allen-Bradley PLC)

Allen-Bradley Example

You turn ON multiple lamps in the same manner as turning ON individual lamps. In this example, we are turning ON bits 2 and 3 of N7:0 and turning ON bit 6 in N7:1.

Example showing how to turn ON Lamp Nos. 3, 4 and 23 with Allen-Bradley PLC

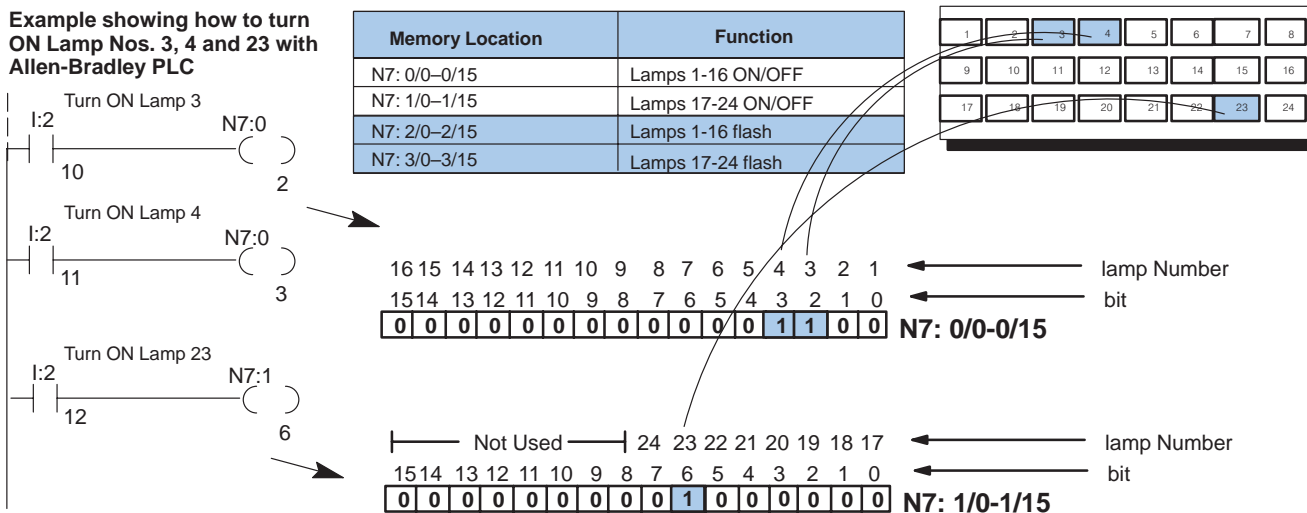

Adding the Flash Option (Allen-Bradley PLC)

Allen-Bradley Example

Bits in N7:2 and N7:3 control the flashing feature. Notice that you must turn ON the lamp before the flash can be added.

Example showing how to turn ON Lamp No. 4 and also make it flash using an Allen-Bradley PLC.

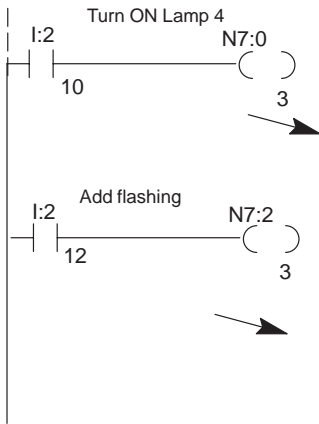

Memory Location	Function
N7: 0/0-0/15	Lamps 1-16 ON/OFF
N7: 1/0-1/15	Lamps 17-24 ON/OFF
N7: 2/0-2/15	Lamps 1-16 flash
N7: 3/0-3/15	Lamps 17-24 flash

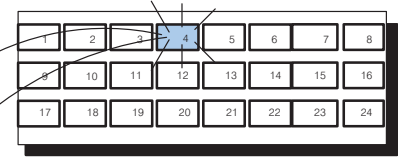

Lamp 4 turns ON and flashes

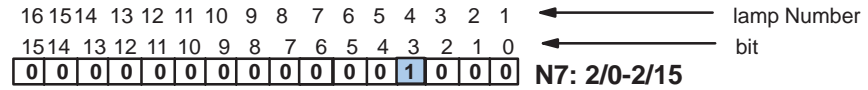
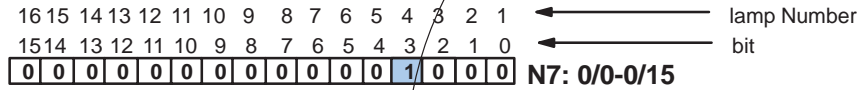

Test Routine for Checking Lamp Operation

This is a simple test routine for checking the lamp operation for your OP-1124 panel. Notice for *PLC Direct* we have chosen to use the starting address V40600 which is the starting address for internal control relays (C0–C17). By using the internal control relays, you can avoid having to load hexadecimal values into an accumulator and outputting to V-memory. When the shift register is turned ON, each lamp should turn ON sequentially starting with Lamp 1 and proceeding to Lamp 24. When the Shift Register finally turns ON C27 (Lamp 24), it resets to zero.

For the Allen-Bradley, we are using a starting address of N7:0/0. We have created a Bit Shift Left Register with 25 bits. We are sequentially turning ON bits from left to right in the shift register. This turns on Lamps 1 through 24 one at a time. When the 25th bit is reached, the shift register is reset by loading 0's in each of the bit positions.

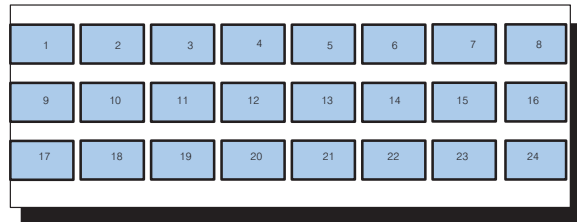

PLC Direct Ladder Logic

Control	Row	Address	Relay Bits
ON/OFF	1 and 2	V40600	C0–C17
	3	V40601	C20–C27

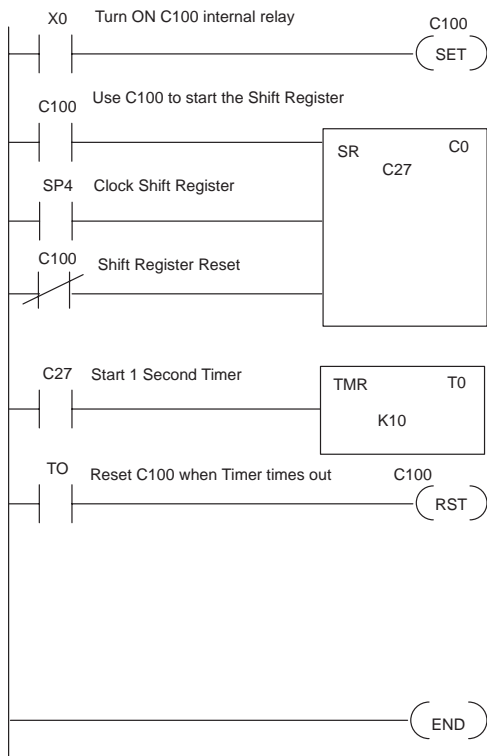

Allen-Bradley Ladder Logic

Control	Row	Address
ON/OFF	1 and 2	N7:0/0–0/15
	3	N7:1/0–1/7

