

Installing the Panel

In this section, you will be given all of the information you need to install the panel. Before actually installing the OP-1224 panel, it may be helpful to examine the specifications and make sure that the requirements of your application are met.

Panel Specifications:

Physical Specifications

Weight	22 ounces
Panel Fasteners	Four 6x32 threaded studs
NEMA Rating	NEMA 4

Environmental Specifications

Operating Temperature	0° to 50° C
Storage Temperature	-20° to 80° C
Operating Humidity	5 to 95% (non-condensing)
Air Composition	No corrosive gases permitted

Operating Specifications

Power Budget Requirement	4 VA @ 8 – 30 VDC
	240 mA @ 12 VDC (all LEDs OFF)
	310 mA @ 12 VDC (all LEDs ON)
	120 mA @ 24 VDC (all LEDs OFF)
	155 mA @ 24 VDC (all LEDs ON)
Power Connector	Removable Terminal Block 2 position
Absolute Maximum Voltage	32 VDC
Diagnostics	Power On, CPU
Communication Link	RS232 or RS422 4800, 9600 and 19200* baud 15 pin female D type connector *Only 4800 and 9600 baud will work with Allen-Bradley PLCs.

Dimensions for Mounting

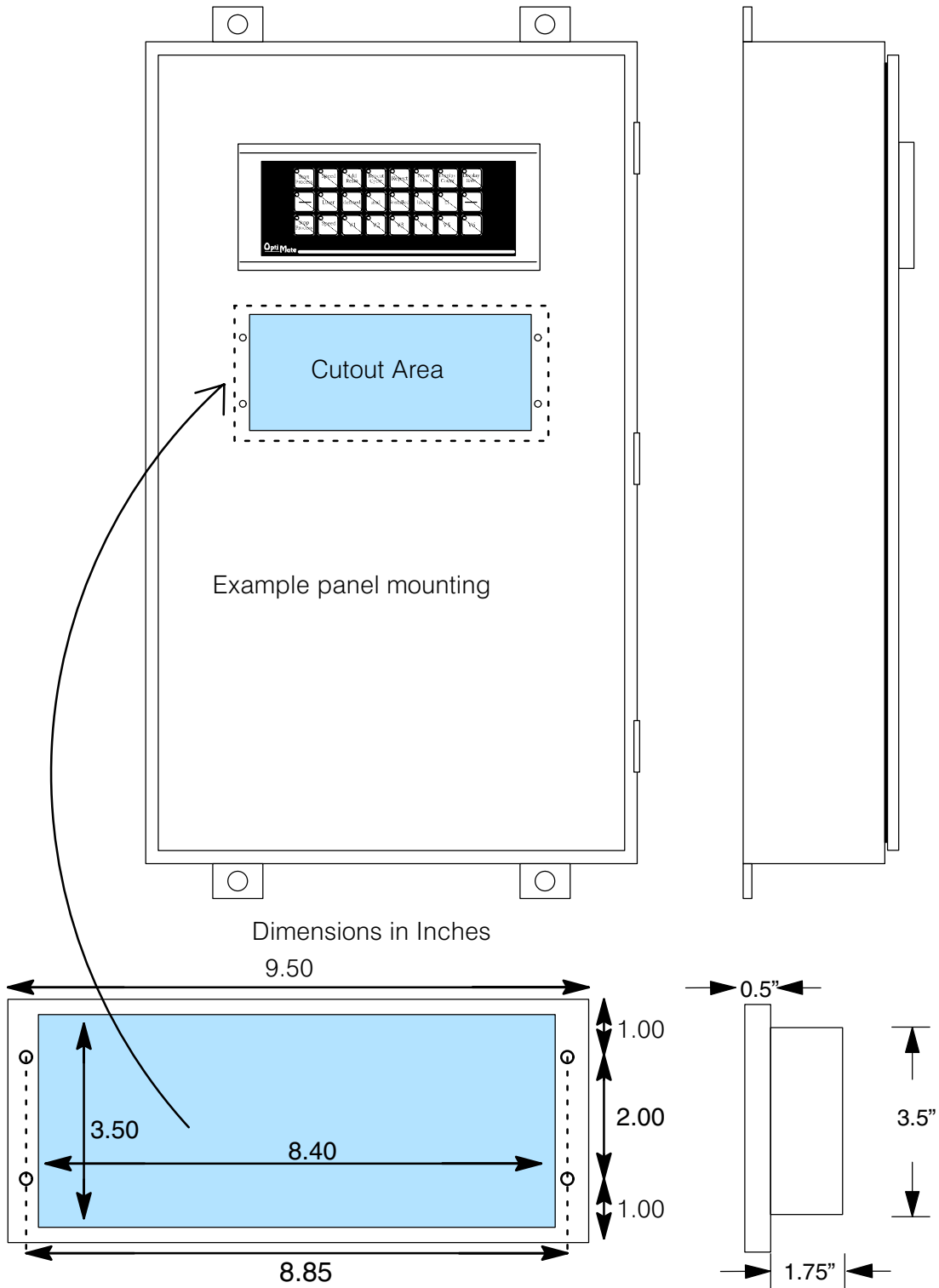

Power and Cabling Requirements

What Are Your Application Needs?

Your communication cable requirements really depend on your particular application. There are two types of configuration possibilities. Point-to-point — a single operator interface connected to a CPU. Multi-drop — multiple operator interfaces connected to a CPU.

- **Point-to-Point** – If you only need one operator interface connected to one CPU, then just choose the appropriate cables from the chart on Page 13, and you're ready to go!
- **Multi-drop** – By using an OptiMate OP-9001 Communications Master, you can connect multiple Optimate units to a single CPU. Up to 31 individual units can be connected in a daisy-chain fashion to the OP-9001. Communications are via RS422 between the OP-9001 and the operator interfaces. If you use a good quality shielded cable, you can have a total distance of up to 4000 feet between the OP-9001 and the last operator interface unit in the chain. If you only have a short distance (up to 30 feet), you can use ribbon cable and easy-to-install crimp-on ribbon connectors.

1. Point-to-Point

A single cable connection from the PLC to the panel gives you access to the PLC's data registers and ladder logic.

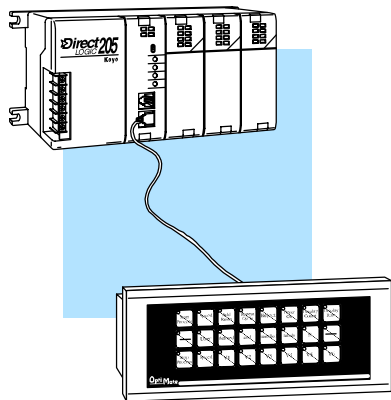

2. Multi-drop

Multiple OP-panels can be interfaced to a single PLC. This requires the use of the OP-9001 Communications Master. With the Communication Master, up to 31 panels can be interfaced to a single CPU port. Each can be programmed for entirely different functions. Panels can be distributed up to 4000 feet* from the OP-9001.

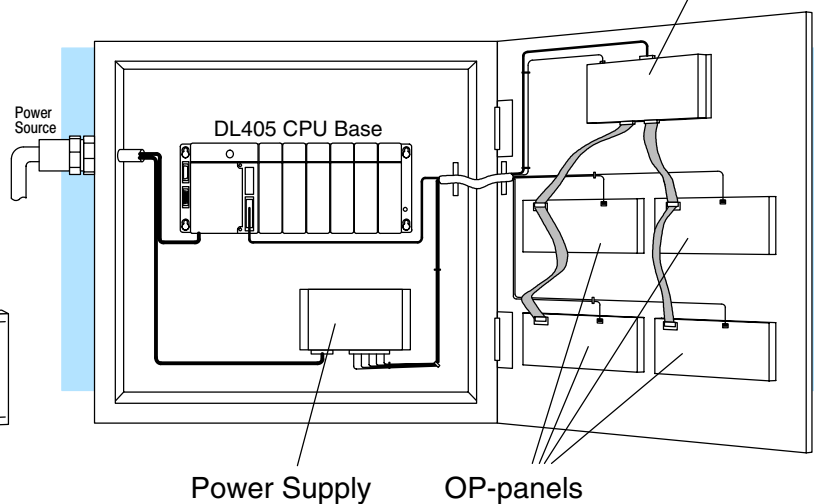

NOTE: Please read and follow the cabling requirements in the OP-9001 User Manual (OP-9001-M) when using multiple panels. Failure to follow the guidelines of the User Manual may affect the integrity of the RS422 link, resulting in communication errors.

Programming Cable The OP-ACBL-1 is used to connect your OP-1224 panel to your computer for programming.

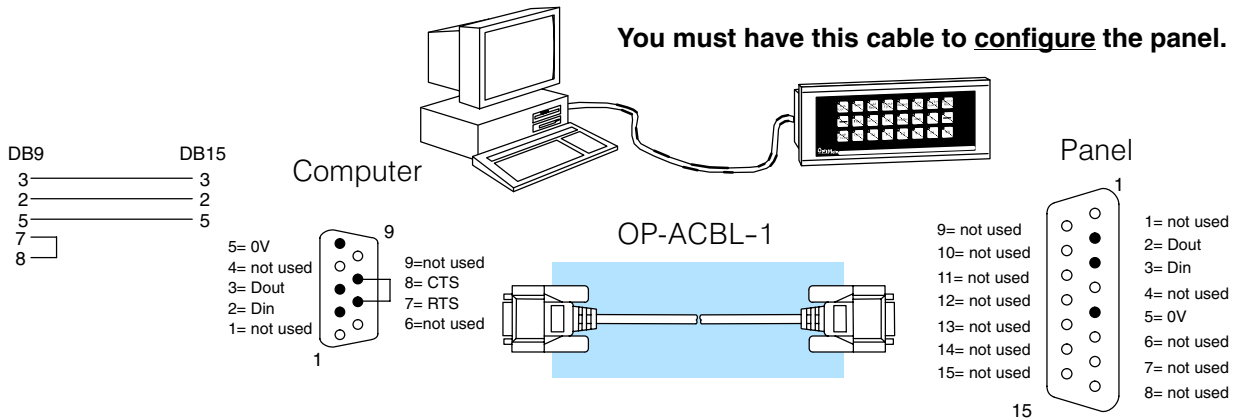

PLC to Panel Cable The OP-ACBL-1 (shown above) is also used to connect Allen-Bradley SLC 5/03 and 5/04 PLCs to an OP-1224 panel. Since the OP-1224 is compatible with all of the **AutomationDirect** and compatible CPUs, your cabling requirements will vary depending on the CPU type you are using. Refer to the table on the next page for matching the proper cable to your PLC. Pin diagrams refer to the ends of the cables and not the communication ports.

See the next page for matching your PLC to the correct cable.

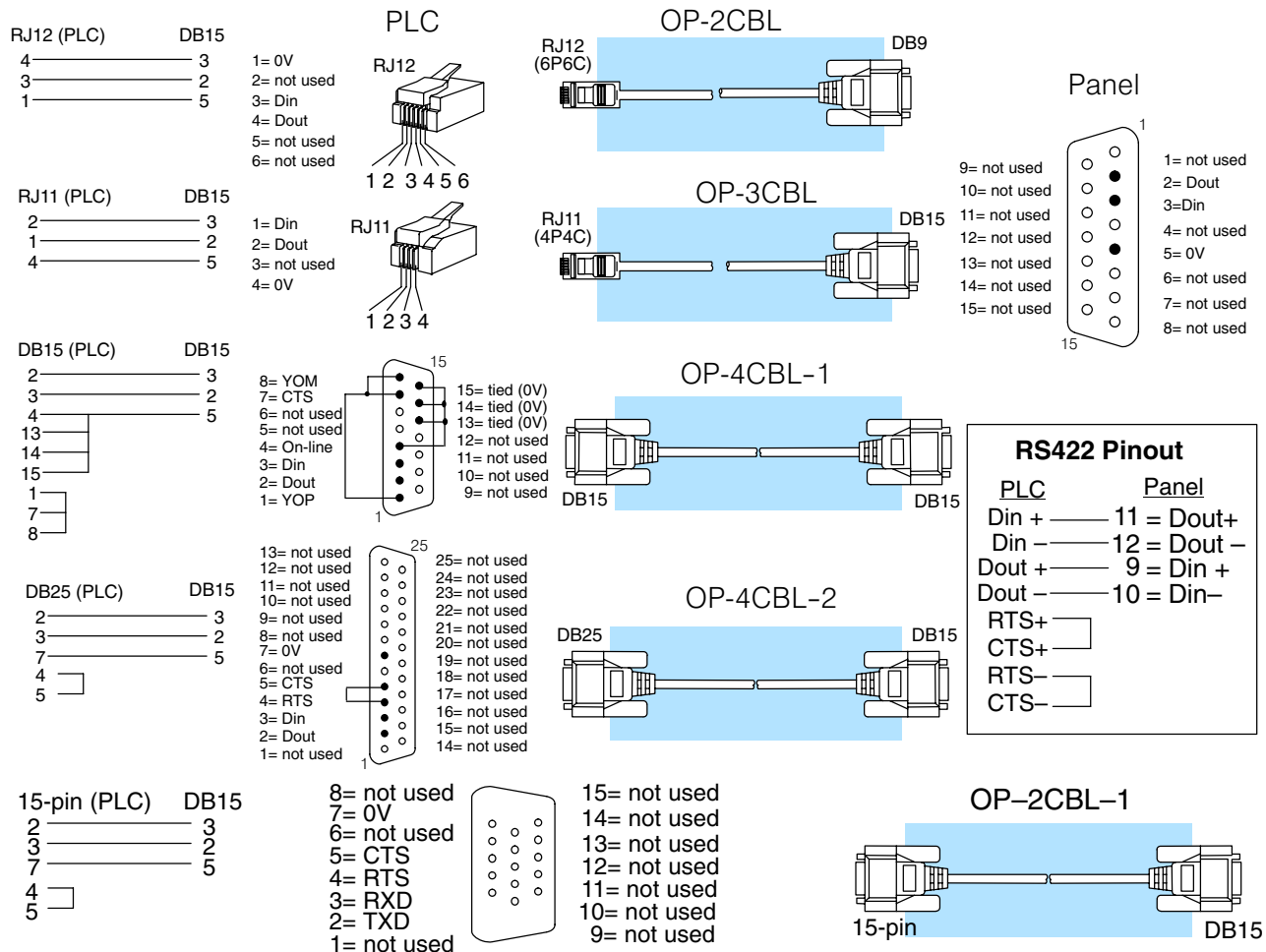

Choosing the Proper Connecting Cables

OptiMate Panel Cables

Depending on which PLC you are using, you may require as many as two cables—one to connect the panel to a personal computer for configuration; and one to connect the panel to the PLC. Here are the requirements:

- **OP-ACBL-1:** *all* units require this cable for configuration. This is a 9-pin male to 15-pin male cable that connects your personal computer to the OptiMate unit. (This cable is also used to connect an OptiMate panel to the Allen-Bradley SLC-500 CPU.
- **CPU Cables:** You will also need the appropriate cable to connect your CPU to the OptiMate unit. Use the chart shown to the right to choose the correct communications cable.

OP-9001 Cable Connectors

If you're planning to use multiple panels and an OP-9001, then you'll need to build your own custom cables. Since the proper cable choice really depends on your application, we offer the following connectors.

- **OP-CMCON-1** — pack of 4 ribbon cable connectors.
- **OP-CMCON-2** — pack of 4 solder-type connectors.

For electrically noisy environments, we recommend a good shielded cable, such as Belden 9729 or equivalent. This type of cable will require the solder-type connectors. If you're going 30 feet or less, you can use ribbon cable. For ribbon cable, we recommend Belden 9L28015 or 3M 3365/15. See Page 14 for more information.

OptiMate Cables			
Family	CPU (or other device)	Port	Cable
<i>Direct</i> LOGIC- DL105	DL130	Only port	OP-2CBL
<i>Direct</i> LOGIC™ DL205	DL230	One port (RJ12)	OP-2CBL
	DL240	Top port (RJ12)	OP-2CBL
		Bottom port (RJ12)	OP-2CBL
<i>Direct</i> LOGIC™ DL305	DL330	Requires DCU*	OP-4CBL-2
	DL330P	Requires DCU*	OP-4CBL-2
	DL340	Top port (RJ11)	OP-3CBL
	DL340	Bottom port (RJ11)	OP-3CBL
	DL350	Top port	OP-2CBL
		Bottom port	OP-4CBL-2
<i>Direct</i> LOGIC™ DL405***	DL430	Top port (15-pin)	OP-4CBL-1
		Bottom port (25-pin)	OP-4CBL-2
	DL440**	Top port (15-pin)	OP-4CBL-1
		Bottom port (25-pin)	OP-4CBL-2
	DL450	Phone Jack (RJ12)	OP-2CBL
		Top port (15-pin)	OP-4CBL-1
		Bottom port (25-pin)	OP-4CBL-2
	D4-DCM (module)	One port (25-pin)	OP-4CBL-2
	Slice I/O panels	One port (15-pin)	OP-4CBL-1
GE® Series 1	IC610CPU105	Requires DCU*	OP-4CBL-2
	IC610CPU106	Requires DCU*	OP-4CBL-2
TI305™ / SIMATIC® TI305™	325-07, PPX:325-07	Requires DCU*	OP-4CBL-2
	330-37, PPX:330-37	Requires DCU*	OP-4CBL-2
	325S-07 (or 325 w/ Stage Kt)	Requires DCU*	OP-4CBL-2
	330S-37, PPX:330S-37	Requires DCU*	OP-4CBL-2
	335-37, PPX:335-37	Phone Jacks (RJ11)	OP-3CBL
If DCU is used*		OP-4CBL-2	
TI405™ / SIMATIC® TI405™	425-CPU, PPX:425-CPU **	One port (15-pin)	OP-4CBL-1
	430-CPU, PPX:430-CPU	Top port (15-pin)	OP-4CBL-1
		Bottom port (25-pin)	OP-4CBL-2
	435-CPU, PPX:435-CPU **	Top port (15-pin)	OP-4CBL-1
		Bottom port (25-pin)	OP-4CBL-2
Smart Slice™ I/O panels	One port (15-pin)	OP-4CBL-1	
Allen-Bradley SLC500	5/03 5/04	Bottom port	OP-ACBL-1
Allen-Bradley	MicroLogix	Only port	OP-ACBL-2

* — requires RS232 Data Communications Unit (D3-232-DCU)

** — also DC versions

Connecting a Power Supply

Power Supply Connections

The OP-1224 panel can operate on DC voltages between 8 and 30 VDC rated at 4 watts. Connect the panel to a power supply (within the required voltage range and wattage) using the terminal block connector supplied. The connector is polarized to prevent reversing the connections. The male receptacle on the rear of the panel will only connect in one way with the female connector that is supplied with your OP-1224 panel. Pin 1 is the positive connection, while Pin 2 is the negative, or ground, connection.

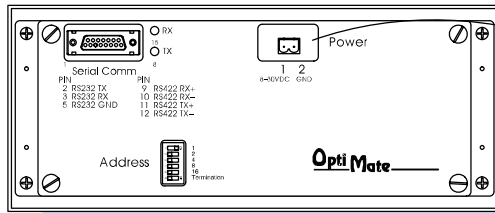

You must use an external power supply that can deliver voltages in the 8 to 30 VDC range, and can supply 4 watts of power.

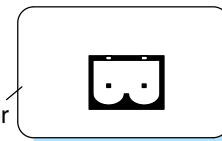

A two-prong male connector is on the rear of the unit. Your OP-panel is shipped with the female connector.

1 2
+ GND

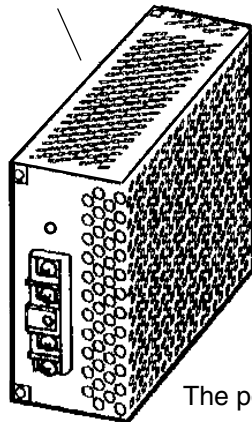

Install the female connector to a cable for attachment to your power supply.

The power supply is not sold by *PLCDirect*.

Model	Current Consumed at 12VDC	Current Consumed at 24VDC
OP-1224	0.24A (all LEDs OFF)	0.12A (all LEDs OFF)
	0.31A (all LEDs ON)	0.16A (all LEDs ON)

Connecting the Panel to your Personal Computer

Assigning an Address to the OP-1224

A 6-position DIP switch on the rear of the OP-1224 allows you to assign a hardware Address to your panel. Each panel must have a unique address. You can use any address between 0 and 30 when communicating between a panel and a PLC or the OP-9001 Master Communications panel. Address 31, however, is reserved. See the note that follows.

NOTE: You must use Address No. 31 when you are using the OPEditor software to download to your OP-1224 panel. No other address will work for the configuration process. In a similar manner, if you are connecting more that one OP-panel to a single CPU (through an OP-9001), then the OP-9001 needs to know which set of configuration parameters belong to which OP-panel. You do this by assigning an address in the range of 0 to 30 to each panel connected. Each panel must have a different address.

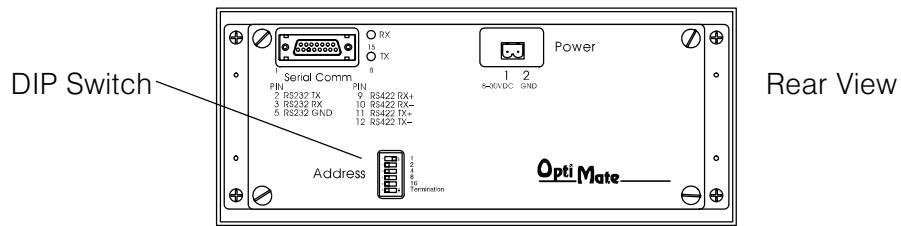

How to Set the Address

To set the address on the OP-1224, simply set the appropriate switches on the dip switch to the desired address. The figure below shows the binary weighting of each switch position. Notice that it is in decimal format. To select address 14 for example, you would press switches 2, 3 and 4 down to the right, and switches 1, 3 and 5 to the left ($2 + 4 + 8 = 14$). Any address between 0 and 30 is valid for the OptiMate-to-CPU (or to OP9001) communications. Address 31, however selects the configuration mode. Use this mode when you connect your personal computer to the panel for configuration. To select address 31, turn switches 1 through 5 ON.

NOTE: Please note that when the dip switches are changed, the OP-1224 must be power cycled before the new settings will take effect.

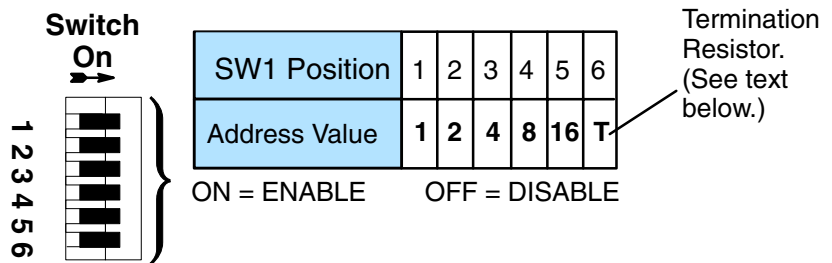

The Termination Resistor

Switch position 6 enables or disables an internal termination resistor. The OptiMate panels communicate via an RS232 or RS422 communications network. If you are using a single panel that will be located less than 50 feet from the CPU, then you can use RS232 and are not required to use a termination resistor (i.e. switch position 6 is turned OFF).

*If a panel will be located more than 50 feet from the CPU or you want to use multiple panels, you **must** use RS422. For single panel installations, this means that switch 6 must be enabled (ON). For multi-drop installations, this means **the last panel only** must have switch 6 enabled (ON). All other panels must have switch 6 disabled (OFF). A more detailed description of multiple panel installations is given in the OP-9001-M User Manual.*

Using the OP-9001 to Connect Multiple Panels

With the addition of the OP-9001 Communications Master panel, you can connect up to 31 panels per a useable CPU port of the PLC. Shown below are the connection requirements. For specifics of the OP-9001 panel itself, please refer to the Communications Master User Manual (OP-9001-M).

NOTE: The OP-9001 must be used in a multiple panel configuration.

Ribbon cable with DB15 male connectors attached.
Panels can be connected directly to the OP-9001 ports or be daisy-chained to other OP-panels.

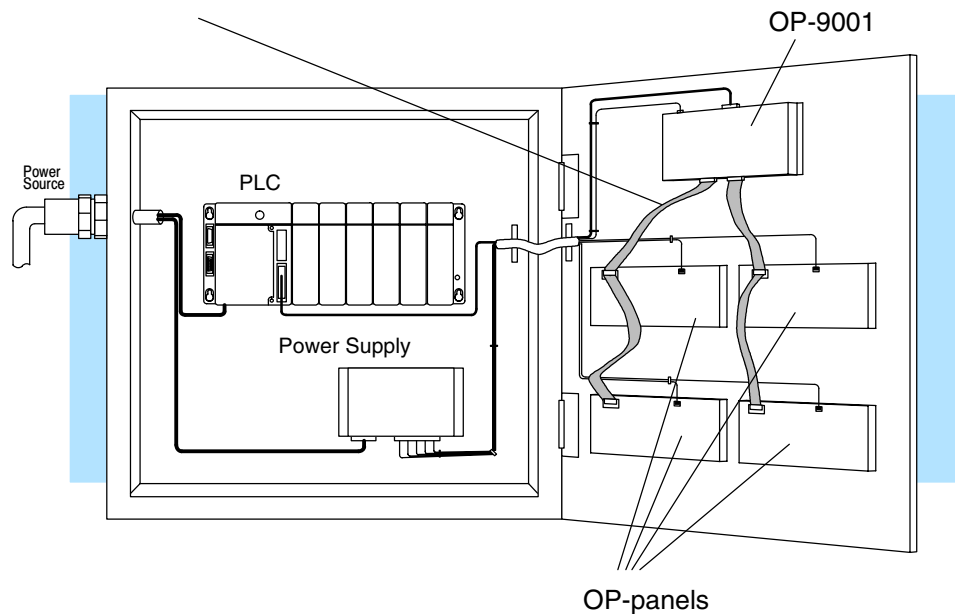

Note: Panels can be located as far away as 4000 feet from the OP-9001 when using shielded cable (Belden 9729 or equivalent). Flat ribbon connections can be used for a distance of 30 feet maximum. For ribbon cable, we recommend Belden 9L28015 or 3M 3365/15.

Belden 9279 Specifications	
No. twisted pairs	2
Nom. Impedance (ohms)	100
Nom. Capacitance (pF/m)	41.0
Wire Gauge (AWG)	24

