

General Overview

The OP-609 Combination Panel features 6 high intensity LED light bars and 9 pushbuttons. Each of the lamps can be individually controlled to be on, off, or flash. Each of the pushbuttons can be individually configured to operate as either a momentary or alternate action pushbutton.

Lamps and pushbuttons can be custom labeled by the user with plastic inserts. The inserts can be legended with text and/or graphics, and slip into protective pockets behind the faceplate.

The OP-609 Lamp/Pushbutton Panel is part of Optimization's **OptiMate**[®] series. Each OptiMate module is designed to connect to a PLC with a single cable connection. OptiMate modules can be used individually, or together with any combination of other OptiMate modules.

When used with a PLC, operation is transparent to the user. Lamps and buttons appear in the PLC ladder logic as coils and contacts. The OP-609 takes care of the rest.

Applications

- Machine control
- Process control
- Security systems
- HVAC
- Plant monitoring/control
- PLC applications

Features

- 6 Plug-In LED Light Bars
- 9 tactile snap membrane pushbuttons
- Independently configurable for momentary or alternate action
- User legenable
- PLC compatible
- RS232/RS422 communications
- Stand alone operation capable
- Multipanel operation capable

OP-609 Combination Panel

Contents

Configuration Options

Stand Alone
PLC Multi-Panel

Use with a PLC

Examples of Use with a PLC
Direct PLC

Examples of Use with an Allen-Bradley PLC

Setup and Interconnect

Legending the Lamps and
Buttons

Connection to the System

Configuration

Configuration Selections Specifications

OptiMate is a registered trademark of
Optimization, Inc.

copyright ©1997, Optimization, Inc.

Configuration Options

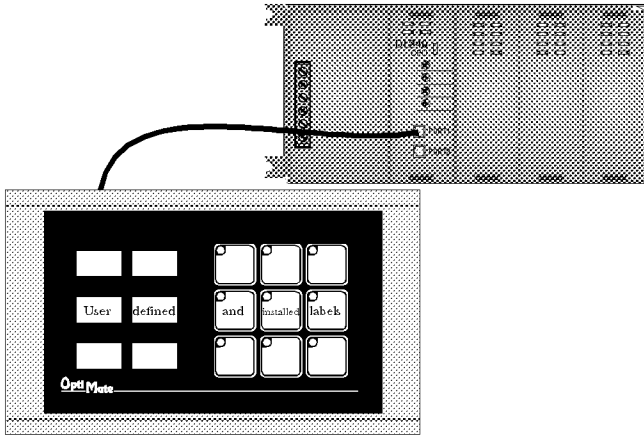

PLC Stand Alone

OptiMate panels plug directly into most PLCs. A simple cable connection allows you to interface and control the OptiMate module via PLC data registers.

The OP-609 Lamp/Pushbutton module uses a bank of four PLC registers to hold pushbutton state, control lights and force pushbutton states. The OP-609 continuously communicates with the PLC registers and updates lamp operation and button status on a real time basis.

PLCs are slave devices on their standard communications ports. This means that a panel attached to the standard port must control the transfer of information by reading and writing the PLC registers. OptiMate panels will perform this communications for most major PLC protocols. Configuration for particular PLC protocols and interconnect cabling is covered in the following pages.

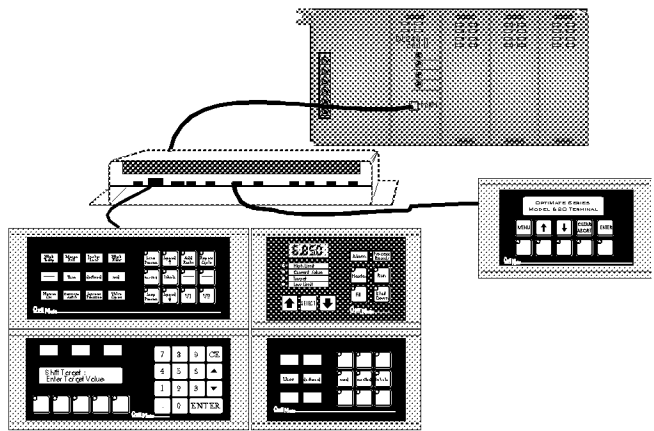

PLC Multi Modules

Larger systems involving operator panels can be successfully addressed using OptiMate modules. These applications utilize the OP-9001 Communications Master to transfer data between the PLC and the individual OptiMate modules. OptiMate panels can be located together to form custom panels or they can be distributed anywhere within 4000 feet.

The OP-9001 Communications Master provides a transparent interface between the PLC and a group of OptiMate modules. The communication interface between modules requires only four wires.

System configuration is simple via OP-WINEDIT configuration software that runs on any IBM PC compatible computer with the Windows operating system. Downloading of the configuration to the module requires a cable connection between the panel and the serial port of the PC.

This modular approach to custom applications provides a nearly limitless number of possibilities.

Use with a PLC

Memory Mapping

Memory mapping is a technique that “maps” the memory of an OptiMate module into the holding registers of the programmable controller. By knowing where the data of the specific OptiMate panel is mapped, this data can be moved, changed or monitored using ladder logic.

The term PLC register is used by for the area of memory within the programmable controller that can be used for data storage. PLC registers are sometimes know as data registers or internal registers.

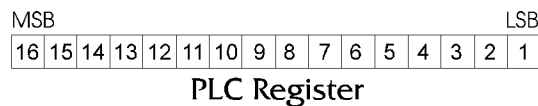

The OP-609 Lamp/Pushbutton Module uses a bank of 4 contiguous holding registers. The register set definition is shown in the table below.

OP-609 Lamp/Pushbutton Panel PLC Register Map	
Holding Register	Register Function
X (first register of bank)	Indicator lamps and button LEDs on/off control
X+1	Indicator lamps and button LEDs flash control
X+2	Button on/off status
X+3	Force pushbutton data & commands

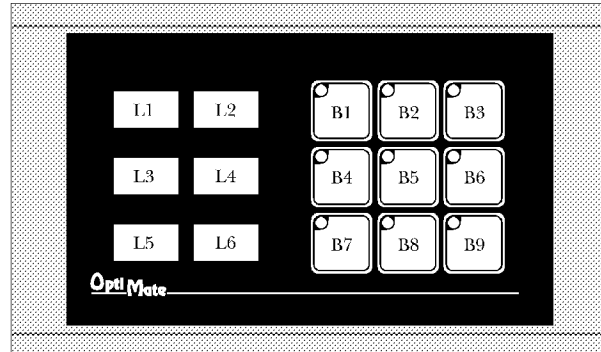

Configuration

Configuration of the OP-609 or system of OptiMate panels is performed via an IBM PC compatible computer. The OP-WINEDIT configuration software will allow you to select module configuration, system configuration and PLC protocol definition.

If the panel is to be operated in stand alone mode, with a PLC, the configuration selections must be made to select the proper PLC protocol information.

If the panel is part of a multi-panel system, the configuration editor will automatically set up communications with between the OP-9001 and the panel via OptiMate Hex. The OP-9001 Communications Master will talk the the module over this protocol and to the PLC over the PLC protocol you select.

Note : When configuring, always remember to set the Run/Pgm DIP switch to PGM (towards the “ON”) before applying power to the module.

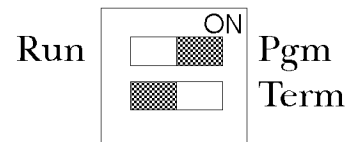

When you are finished downloading configuration, power down the panel and switch to the “Run” position before connecting to the PLC.

Further configuration details are covered in the OP-WINEDIT help screens.

Register	MSB						LSB									
X	L6	L5	L4	L3	L2	L1	B9	B8	B7	B6	B5	B4	B3	B2	B1	Indicator Light/LED On/Off
X+1	L6	L5	L4	L3	L2	L1	B9	B8	B7	B6	B5	B4	B3	B2	B1	Indicator Light/LED Flash Control
X+2							B9	B8	B7	B6	B5	B4	B3	B2	B1	Button On/Off Status
X+3	F1	F2	F3				B9	B8	B7	B6	B5	B4	B3	B2	B1	Force Data & Commands

Register Bit Association

Reading Pushbutton Status

Once the panel is configured and connected to the PLC, reading a button's status simply entails reading the appropriate register bit. In typical applications, a pushbutton appears in PLC ladder logic as a contact. The register bit association is shown in the figure below. The panel will automatically place status into this register. A 1 indicates active or "on" condition.

Turning on a Lamp

When configured for PLC operation, turning on a lamp simply requires the writing of a 1 to the appropriate register bit. With most PLCs this is accomplished by activating a coil in the PLCs ladder logic. The OptiMate panel will automatically retrieve the register data and light any lamps whose bits are set.

A lamp must be turned on in order for the flash control bits to have any effect.

Flashing a Lamp

As shown in the table, the second register will initiate lamp flash. To flash a lamp, the lamp must be on and lamp flash bit must be set.

Lamp flash is approximately .5 seconds on and .25 seconds off.

Turning on the Inset Indicator Light

In most cases, the LED inset in each pushbutton simply provides a visual indication of the status of the pushbutton. However, if a module is configured for LED separation mode, the indicator light can be set directly from the PLC. In LED separation mode, turning on a lamp simply requires the writing of a 1 to the appropriate register bit. The register bit association is shown in the table on the previous page. The OptiMate panel will automatically retrieve the register data and illuminate any lamps whose bits are set.

LED separation is available only for momentary pushbuttons.

Flashing an Inset LED

As shown in the table, the second register will initiate inset LED flash. To flash an LED, the LED must be on and LED flash bit must be set. In normal mode, LED "on" status simply reflects pushbutton status. In LED separation mode, LED "on" status is set directly via PLC register bits.

Lamp flash is approximately .5 seconds on and .25 seconds off.

Register	MSB						LSB									
X	L6	L5	L4	L3	L2	L1									Indicator Light/LED On/Off	
X+1	L6	L5	L4	L3	L2	L1									Indicator Light/LED Flash Control	
X+2							B9	B8	B7	B6	B5	B4	B3	B2	B1	Button On/Off Status
X+3	F1	F2	F3				B9	B8	B7	B6	B5	B4	B3	B2	B1	Force Data & Commands

Register Bit Association

Force Commands

If the OP-609 panel is configured for force capability, the PLC can directly control button status when desired. This may be desirable for initialization purposes.

The force capability also may prove useful for functions initiated from the pushbutton panel. For example, consider a situation where an operator initiates a control process by pressing an alternate action panel button. The button status and inset LED would stay on and lighted to indicate that the function is still in process. At the end of the process, the PLC program could force the button status off.

There are three types of force functions available. These are described below.

Force function	Description
F1 (Force buttons status)	When the F1 bit is set, all buttons will be forced to the status set in the force data registers (x+3). Once these buttons are forced to the status set, the OP-609 will automatically clear F1.
F2 (Force buttons on)	When the F2 bit is set, all buttons matching the bits set in the force data registers (x+3) will be forced on. Once these buttons are forced on, the OP-609 will automatically clear F2.
F3 (Clear buttons)	When the F3 bit is set, all buttons matching the bits set in the force data registers (x+3) will be forced off. Once these buttons are forced off, the OP-609 will automatically clear F3.

Force applies only to alternate action pushbuttons.

Examples of Use with a PLC *Direct* PLC

Defining the Base Register Address

The simplest method of interfacing a PLC *Direct* PLC program to an OP-609 module is to configure the module base address in the PLC's control relay memory. This allows your program to treat pushbuttons as contacts and LEDs as coils. The following table lists these address for various PLC Direct PLCs.

PLC Direct CPU	Control Relay Register address range
DL130	V40600-V40617
DL230	V40600-V40617
DL240	V40600-V40617
DL250	V40600-V40617
DL330	R016-R037
DL330P	R016-R017 and R020-R027
DL340	R016-R037 and R100-R106
DL350	V40600-V40617
DL430	V40600-V40635
DL440	V40600-V40677
DL450	V40600-V40777

The following examples are DL105, DL205, DL350 or DL405 programs with the OP-609 configured for address V40600. The table below shows the control relay correlation for an OP-609 configured for address V40600.

Device	Lamp/LED On/Off	Lamp/LED Flash	Button Status	Force
B1	C0	C20	C40	C60
B2	C1	C21	C41	C61
B3	C2	C22	C42	C62
B4	C3	C23	C43	C63
B5	C4	C24	C44	C64
B6	C5	C25	C45	C65
B7	C6	C26	C46	C66
B8	C7	C27	C47	C67
B9	C10	C30	C50	C70
L1	C12	C32		
L2	C13	C33		
L3	C14	C34		
L4	C15	C35		C75(F3)
L5	C17	C36		C76(F2)
L6	C17	C37		C77(F1)

Turning on a Lamp

Turning on a lamp in the OP-609 simply requires activating its associated control relay coil. In the figure below, lamp 4 will be turned on whenever input X1 is active (energizing C15).

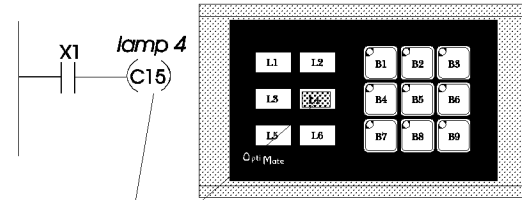

Register	MSB													LSB		
V40600	L6	L5	L4	L3	L2	L1	B9	B8	B7	B6	B5	B4	B3	B2	B1	Indicator Light/LED On/Off Status
V40601	L6	L5	L4	L3	L2	L1	B9	B8	B7	B6	B5	B4	B3	B2	B1	Indicator Light/LED Flash Control
V40602							B9	B8	B7	B6	B5	B4	B3	B2	B1	Button On/Off Status
V40603	F1	F2	F3				B9	B8	B7	B6	B5	B4	B3	B2	B1	Force Data & Commands

Flashing a Lamp

To flash a lamp, you simply need to both turn it on and set the associated flash bit. The example below shows a PLC program used to flash lamp 2 whenever X5 is energized.

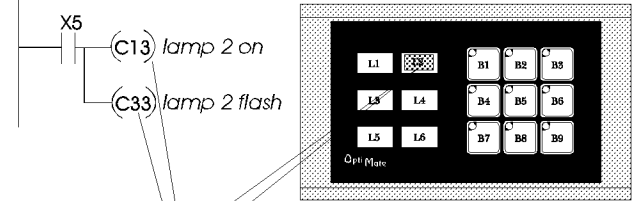

Register	MSB													LSB		
V40600	L6	L5	L4	L3	L2	L1	B9	B8	B7	B6	B5	B4	B3	B2	B1	Indicator Light/LED On/Off Status
V40601	L6	L5	L4	L3	L2	L1	B9	B8	B7	B6	B5	B4	B3	B2	B1	Indicator Light/LED Flash Control
V40602							B9	B8	B7	B6	B5	B4	B3	B2	B1	Button On/Off Status
V40603	F1	F2	F3				B9	B8	B7	B6	B5	B4	B3	B2	B1	Force Data & Commands

Using a Pushbutton

The following example illustrates the use of an OP-609 pushbutton in a program. When pushbutton 3 is activated, C42 will become active and turn on output Y0.

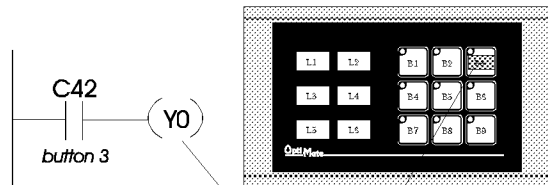

Register	MSB													LSB		
V40600	L6	L5	L4	L3	L2	L1	B9	B8	B7	B6	B5	B4	B3	B2	B1	Indicator Light/LED On/Off Status
V40601	L6	L5	L4	L3	L2	L1	B9	B8	B7	B6	B5	B4	B3	B2	B1	Indicator Light/LED Flash Control
V40602							B9	B8	B7	B6	B5	B4	B3	B2	B1	Button On/Off Status
V40603	F1	F2	F3				B9	B8	B7	B6	B5	B4	B3	B2	B1	Force Data & Commands

Lighting an Inset LED

In LED separation mode, the LEDs in the corner of each momentary pushbutton may be directly controlled by the PLC program. The example on the right shows a segment of a program that will light button 5's inset LED whenever input X7 is energized. *In order for this to work, the panel must be configured for LED separation and button 5 must be a momentary pushbutton.*

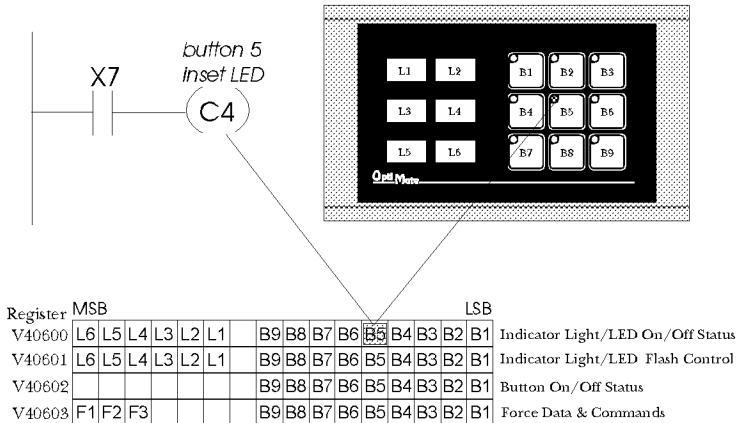

Flashing an Inset LED

To flash an inset LED, you simply need to both turn it on and set the associated flash bit. If the panel is not set up for LED separation, status is simply the button state. For momentary buttons with LED separation enabled, the on/off state is controlled by the PLC as shown in the previous example. For alternate action buttons, on/off state is always the button state.

The example on the right shows a program used to set the LED inset in button 7 to flash whenever X2 is energized. If the panel has been configured with button 7 being an alternate action button, the LED will operate as shown in the table below.

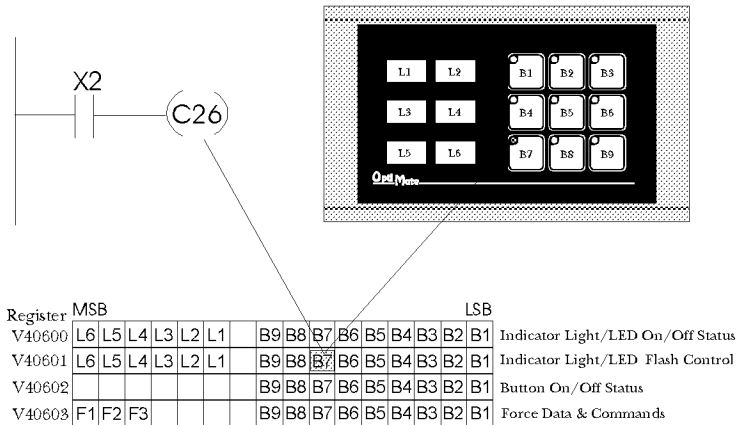

Button State	X2 State	LED operation
Inactive	de-energized	Off
Inactive	energized	Off
Active	de-energized	On solid
Active	energized	Flashing

Forcing Button Status

One of the more advanced capabilities of the OP-609 panel is the ability to force button state from the PLC program. This may be desirable, for example, if an alternate action is used to start a function process. When it is pushed and while the function is active, the button will remain on. You may want the PLC program to clear the button at the end of the function process.

Another example is a system that has individual enable or on/off (alternate action) buttons for several different devices. You may also have other buttons (momentary) that enable a group of these same devices. You may want your program to force on the device enable buttons when the group enable button is pressed.

There are many other cases where button force capability can be useful in a system.

There are three types of force functions available for the OP-609 panel - force status, force on and force off. All three functions require moving appropriate data into the PLC registers defined as Force Data & Commands (see the table below).

Note : Force only applies to Alternate Action pushbuttons

Force Button Status

This function is used to set the state (on or off) of every alternate action pushbutton in the panel. To use the "Force Button Status" function, simply set the F1 bit to 1 and all buttons that you want to be on to 1, while leaving all other bits off. The example below shows buttons 1,5, and 6 being forced on and all other buttons forced off when C377 is active.

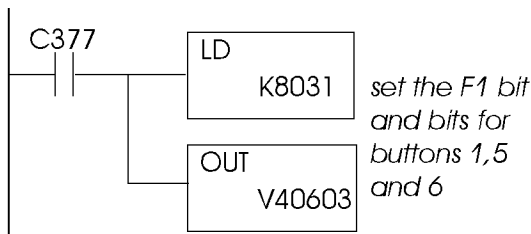

Force Button(s) On

This function is used to turn individual button(s) on without affecting the state of any other buttons. To use the "Force Buttons On" function, set the F2 bit to 1 and all buttons that you want to turn on to 1. Any buttons associated with bits that are left at '0' will not be affected. The following example shows buttons 2 and 7 being forced on when C377 is active.

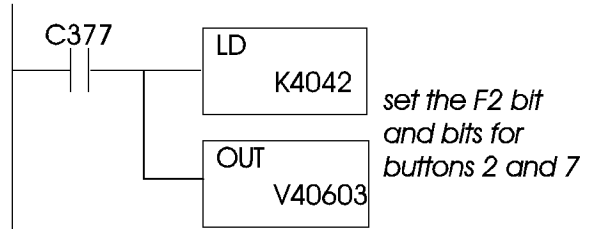

Force Button(s) Off

This function is used to selectively turn individual button(s) off without affecting the state of any other buttons. To use the "Force Buttons Off" function, set the F3 bit to 1 and all buttons that you want to turn off to 1. Any buttons associated with bits that are left as '0' will not be affected. The example below shows buttons 5 and 8 being cleared when C377 is active.

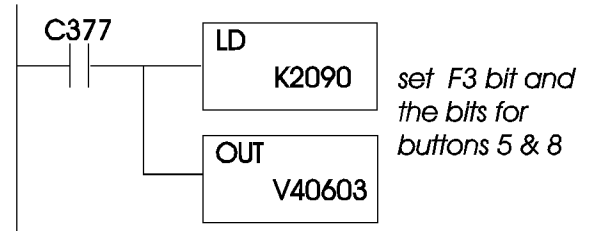

Register	MSB						LSB									
X	L6	L5	L4	L3	L2	L1	B9	B8	B7	B6	B5	B4	B3	B2	B1	Indicator Light/LED On/Off
X+1	L6	L5	L4	L3	L2	L1	B9	B8	B7	B6	B5	B4	B3	B2	B1	Indicator Light/LED Flash Control
X+2							B9	B8	B7	B6	B5	B4	B3	B2	B1	Button On/Off Status
X+3	F1	F2	F3				B9	B8	B7	B6	B5	B4	B3	B2	B1	Force Data & Commands

Register Bit Association

Examples of Use with an Allen Bradley PLC

Interfacing to A/B Memory

OptiMate modules interface to Allen Bradley SLC 5/03, SLC 5/04 and Micrologix PLCs via integer file type N. The 5/03 and 5/04 have file type N7 as standard. Other "N" type files can be created. The Micrologix has a fixed file type N7. Please refer to Allen Bradley programming documentation for information on setting up and using "N" type files. This allows your program to treat pushbuttons as contacts and LEDs as coils.

The following examples are SLC or Micrologix programs with the OP-609 configured for address N7:0. The table below shows the correlation for an OP-609 configured for address N7:00.

Device	Lamp/LED On/Off	Lamp/LED Flash	Button Status	Force
B1	N7:0/0	N7:1/0	N7:2/0	N7:3/0
B2	N7:0/1	N7:1/1	N7:2/1	N7:3/1
B3	N7:0/2	N7:1/2	N7:2/2	N7:3/2
B4	N7:0/3	N7:1/3	N7:2/3	N7:3/3
B5	N7:0/4	N7:1/4	N7:2/4	N7:3/4
B6	N7:0/5	N7:1/5	N7:2/5	N7:3/5
B7	N7:0/6	N7:1/6	N7:2/6	N7:3/6
B8	N7:0/7	N7:1/7	N7:2/7	N7:3/7
B9	N7:0/8	N7:1/8	N7:2/8	N7:3/8
L1	N7:0/10	N7:1/10		
L2	N7:0/11	N7:1/11		
L3	N7:0/12	N7:1/12		
L4	N7:0/13	N7:1/13		N7:3/13(F3)
L5	N7:0/14	N7:1/14		N7:3/14(F2)
L6	N7:0/15	N7:1/15		N7:3/15(F1)

Flashing a Lamp

To flash a lamp, you need to both turn it on and set the associated flash bit. The example below shows a SLC or Micrologix program used to flash lamp 2 whenever I:0.0/4 is energized.

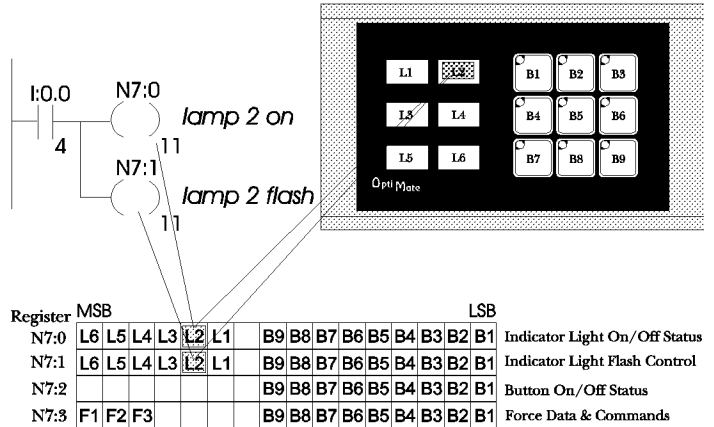

Using a Pushbutton

The following example illustrates the use of an OP-609 with a SLC or Micrologix PLC. When button 5 is activated, N7:2/4 will become active and turn on output O:0.0/5.

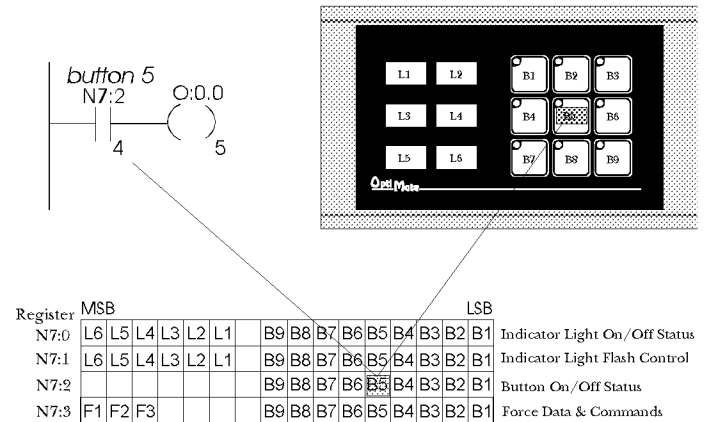

Turning on a Lamp

Turning on a lamp in the OP-609 simply requires activating its associated control relay coil. In the figure below, lamp 4 will be turned on whenever input I:0.0/4 is active (energizing N7:0/13).

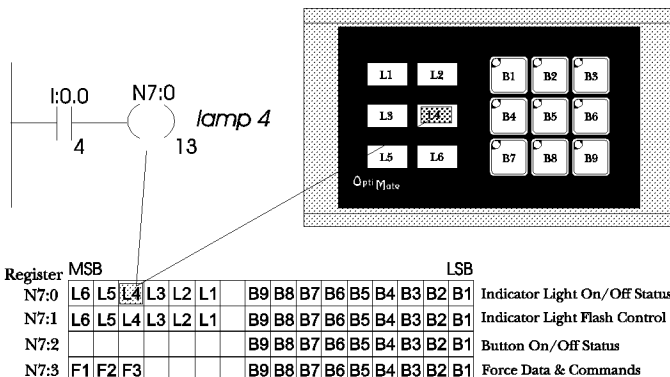

Lighting an Inset LED

In LED separation mode, the LEDs in the corner of each momentary pushbutton may be directly controlled by the PLC program. The example on the right shows a segment of a SLC or Micrologix program that will light button 6's inset LED whenever input I0.2/12 is energized. *In order for this to work, the panel must be configured for LED separation and button 6 must be a momentary pushbutton.*

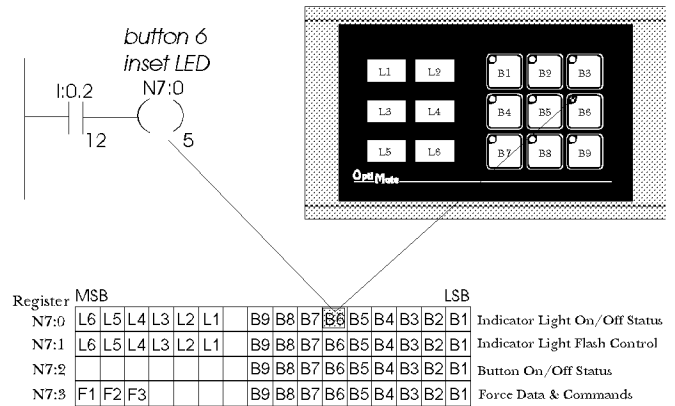

Flashing an Inset LED

To flash an inset LED, you need to both turn it on and set the associated flash bit. If the panel is not set up for LED separation, status is simply the button state. For momentary buttons with LED separation enabled, the on/off state is controlled by the PLC as shown in the previous example. For alternate action buttons, on/off state is always the button state.

The example on the right shows a SLC or Micrologix program used to set the LED inset in button 7 to flash whenever I0.3/4 is energized. If the panel has been configured with button 7 being an alternate action button, the LED will operate as shown in the table below.

Button State	I0.3/4 State	LED operation
Inactive	de-energized	Off
Inactive	energized	Off
Active	de-energized	On solid
Active	energized	Flashing

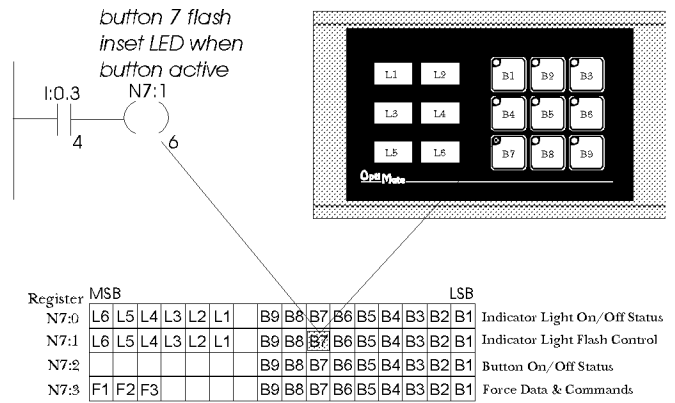

Forcing Button Status

One of the more advanced capabilities of the OP-609 panel is the ability to force button state from the PLC program. This may be desirable, for example, if an alternate action is used to start a function process. When it is pushed and while the function is active, the button will remain on. You may want the PLC program to clear the button at the end of the function process.

Another example is one of a system that has individual enable or on/off (alternate action) buttons for several different devices. You may also have other buttons (probably momentary) that enable a group of these same devices. You may want your program to force on the device enable buttons when the group enable button is pressed.

There are many other cases where button force capability can be useful in a system.

There are three types of force functions available for the OP-609 panel - force status, force on and force off. All three functions require moving appropriate data into the PLC registers defined as Force Data & Commands (see the table below).

Note : Force only applies to Alternate Action pushbuttons

Force Button Status

This function is used to set the state (on or off) of every alternate action pushbutton in the panel. To use the "Force Button Status" function, simply set the F1 bit to 1 and all buttons that you want to be on to 1, while leaving all other bits off. The example below shows buttons 1, 5 and 6 being forced on and all other buttons forced off when B3:4/2 is active.

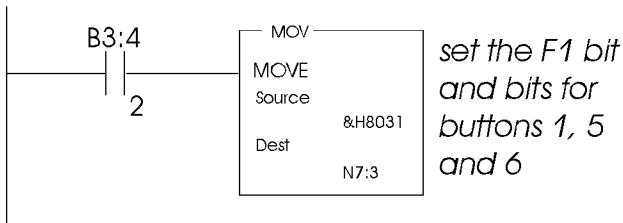

Force Button(s) On

This function is used to turn individual button(s) on without affecting the state of any other buttons. To use the "Force Buttons On" function, set the F2 bit to 1 and all buttons that you want to turn on to 1. Any buttons associated with bits that are left at '0' will not be affected. The following example shows buttons 2 and 7 being forced on when B3:4/2 is active.

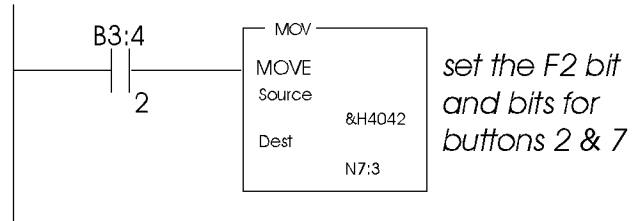

Clear Button(s)

This function is used to selectively turn individual button(s) off without affecting the state of any other buttons. To use the "Clear Buttons" function, set the F3 bit to 1 and all buttons that you want to turn off to 1. Any buttons associated with bits that are left as '0' will not be affected. The example below shows button 5 being cleared when C377 is active.

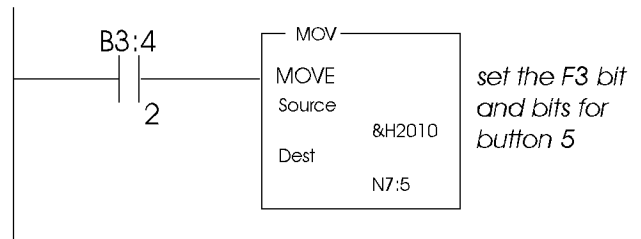

Register	MSB						LSB									
X	L6	L5	L4	L3	L2	L1	B9	B8	B7	B6	B5	B4	B3	B2	B1	Indicator Light/LED On/Off
X+1	L6	L5	L4	L3	L2	L1	B9	B8	B7	B6	B5	B4	B3	B2	B1	Indicator Light/LED Flash Control
X+2							B9	B8	B7	B6	B5	B4	B3	B2	B1	Button On/Off Status
X+3	F1	F2	F3				B9	B8	B7	B6	B5	B4	B3	B2	B1	Force Data & Commands

Register Bit Association

Set Up and Interconnect

Legending the Lamps and Buttons

Legending the OP-609 module is a relatively simple process that basically involves sliding legend transparencies into a pocket in the panel overlay. Use the following procedure.

- Remove the bezel from the module. The bezel snaps to the module box along the top and bottom edges. Pull the bezel out and over the snaps to remove.
- Create a legend transparency. There are a number of available options for doing so. A pattern is provided on the specification sheet of this document.
 - > Use the built in label making capability of the OP-WINEDIT software to create labels. Either print on the transparency directly or print on paper and photocopy onto the transparency. The figure below is a screen from OP-WINEDIT which illustrates the process.

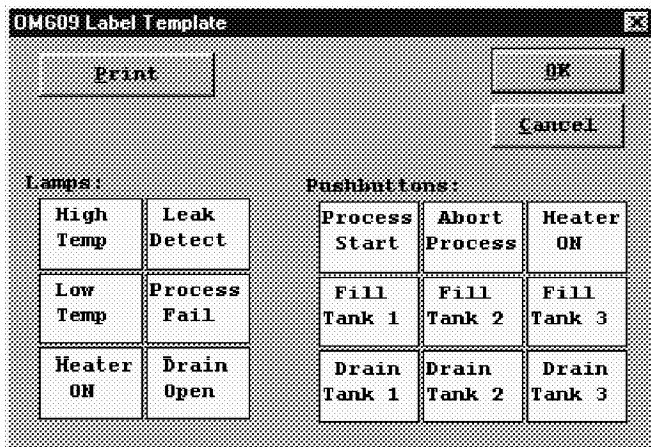
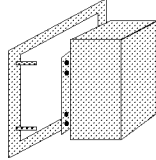

- > Use a computer graphics program and a laser printer to create the transparency directly. Alternately print on paper and photocopy to a transparency.
- > Use press on letters onto a transparency sheet.
- > Use a typewriter or lettering machine to letter onto paper, then photocopy

- Cut along outline. Place into overlay pocket. The OP-609 overlay is not glued to the faceplate. This facilitates changing of LED light bars. The legend transparency should be placed between the overlay and the faceplate. The faceplate and overlay are keyed on both ends to ensure proper alignment when reassembled. (If LED colors do not need to be changed, the overlay may be glued to the faceplate by pulling off the backing and pressing the overlay onto the faceplate).
- Re-attach bezel. Push bezel onto box until it snaps together.

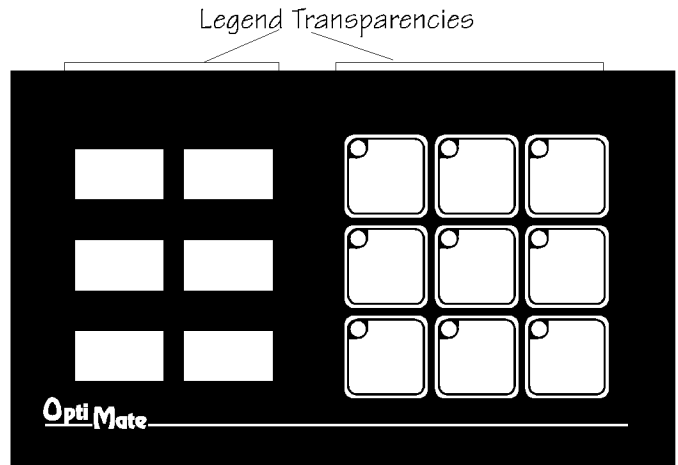

Lamp Colors

OP-609 come with either all red LED light bars or with one row each of red, yellow and green light bars (the -1 option). All light bars are socketed. Light bars are available from Optimization in packets of four.

Replacing a light bar involves removing the bezel and overlay (as in the labeling procedure on the left). Once the bezel and overlay are removed, individual LED light bars may be extracted by use of needle nose pliers. Replacement light bars can be pushed into place. (The light bars are symmetrical, so orientation is not important.)

Configuration

Configuration Selections

OptiMate panels can be configured for the specific application by using the OP-WINEDIT Configuration Editor. The Configuration Editor runs on any IBM PC compatible computer with the Windows operating system. It allows the user to select the exact functionality to meet application requirements.

For the OP-609 panel, the following are important configuration parameters. Further configuration details are covered in the OP-WINEDIT help screens

Single Panel PLC Based Systems

Decision	Selection
Single/Multi Panel	Choose single panel configuration
Configuration starting point	First time configuration start with defaults for module. Subsequent configurations can utilize disk files you create
PLC Type	Select appropriate PLC type
Protocol	Select appropriate baud rate, # data bits, # stop bits & parity. Note that if 8 data bits and even or odd parity selected, only 1 stop bit is available
Momentary/Alternate	Set as required for application
LED Separation	Enable LED separation only if all momentary button inset LEDs are to be controlled from the host PLC
Force Option	Set as required for application

Multi Panel PLC Applications (Uses OP9001 Communications Master)

Decision	Selection
Single/Multi Panel	Choose Multi Panel
PLC Type	This applies to the Communications Master. Choose appropriate type
Protocol	This applies to the Communications Master. Choose appropriate baud rate, # bits, # stop bits & parity. Note that if 8 data bits and even or odd parity are selected, only 1 stop bit is available.
Panel Protocol	Will be OptiMate Hex
Momentary/Alternate	Set as required for application
LED Separation	Enable LED separation only if all momentary buttons are to be controlled from host PLC
Force option	Set as required for application

Configuration must be downloaded from the IBM PC compatible to each panel. This is done over the serial link. Panel must be selected for "Pgm" (DIP switch in back of the module) prior to application of power for panel to accept configuration data. The panel must be powered down and the DIP switch changed from "Pgm" to "Run" before reapplying power for the module to operate with the selected host.

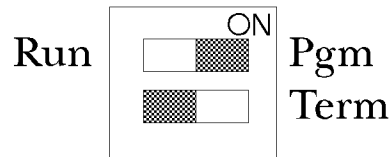

OP-609 Configuration

Panel Address: 0

PLC Base Register Address: V2000

Write to Panel

Close

Labels

Pushbutton Options:

Force Option

LED Separation

Panel:

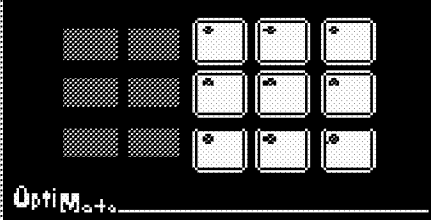

Pushbuttons

	A	M		A	M		A	M
#1:	<input type="radio"/>	<input checked="" type="radio"/>		<input checked="" type="radio"/>	<input type="radio"/>		<input checked="" type="radio"/>	<input type="radio"/>
#2:	<input type="radio"/>	<input checked="" type="radio"/>		<input type="radio"/>	<input checked="" type="radio"/>		<input checked="" type="radio"/>	<input type="radio"/>
#3:	<input type="radio"/>	<input checked="" type="radio"/>		<input checked="" type="radio"/>	<input type="radio"/>		<input checked="" type="radio"/>	<input type="radio"/>
#4:	<input checked="" type="radio"/>	<input type="radio"/>		<input type="radio"/>	<input checked="" type="radio"/>		<input checked="" type="radio"/>	<input type="radio"/>
#5:	<input type="radio"/>	<input checked="" type="radio"/>		<input type="radio"/>	<input checked="" type="radio"/>		<input checked="" type="radio"/>	<input type="radio"/>
#6:	<input checked="" type="radio"/>	<input type="radio"/>		<input checked="" type="radio"/>	<input type="radio"/>		<input checked="" type="radio"/>	<input type="radio"/>
#7:	<input checked="" type="radio"/>	<input type="radio"/>		<input checked="" type="radio"/>	<input type="radio"/>		<input checked="" type="radio"/>	<input type="radio"/>
#8:	<input checked="" type="radio"/>	<input type="radio"/>		<input checked="" type="radio"/>	<input type="radio"/>		<input checked="" type="radio"/>	<input type="radio"/>
#9:	<input checked="" type="radio"/>	<input type="radio"/>		<input checked="" type="radio"/>	<input type="radio"/>		<input checked="" type="radio"/>	<input type="radio"/>

[A = Alternate M = Momentary]

Addressing

Setting the panel address is performed through the OP-WINEDIT editor. The particular address selection for a panel connected directly to a PLC is not important (any address will work). For multi-panel systems, each panel in the system must be assigned a unique address.

Connection to the System

OptiMate panels are designed for communications connection to system devices. The panel can be connected to a computer, PLC or OP-9001 communication master over the serial port (RS232 or RS422).

Connection to a Computer or PLC

Connection of an OptiMate panel to a computer or PLC can be accomplished over either an RS232 or RS422 link. RS232 is limited to one OptiMate panel to one computer serial port. RS422 allows up to 31 panels to be connected to one computer port. Since PLCs are slave devices, the RS422 link for a PLC is limited to one OptiMate panel.

OptiMate Panel RS232		OptiMate Panel RS422	
Host Computer/PLC	OptiMate Panel DB-15 Male	Host Computer/PLC	OptiMate Panel DB-15 Male
TX	3 RS232 RX	TX+	9 RS422 RX+
RX	2 RS232 TX	TX-	10 RS422 RX-
Sig Gnd	5 Sig Gnd	RX+	11 RS422 TX+
		RX-	12 RS422 TX-

Refer to manufacturer's documentation for PLC or computer serial link connector pinouts.

Standard interface cables are available for connection to several different PLCs as well as to IBM PCAT compatible ports.

Serial Connection to Communications Master

Connection to an OP-9001 Communications Master over a serial link is via RS422. The Communication master port connections are reversed from the module ports to enable direct pin to pin connection. For distances under 50 feet (in a low electrical noise environment), a ribbon cable connection works quite well. For longer distances or in noisy environments, a two pair shielded RS422 cable is recommended.

Termination

The termination DIP switch on the back of the module switches in a terminating resistor. This terminating resistor does not apply to an RS232 connection (and should be placed in the OFF position). In an RS422 connected system, the termination should be on in the last, and only the last, panel on the cable.

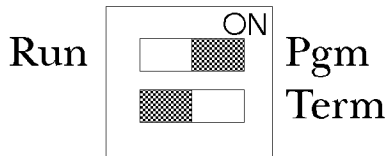

Power

OptiMate modules can operate on any voltage between 8 and 30 VDC. Power must be connected to the terminal plug located on the back of the module.

There is a brief (0.5 to 2 millisecond) power on surge to 2 amps. This is typical of nearly any type of electronic equipment and is due to the initial charging of power capacitors. This surge is not normally a problem for a commercial power supply.

Label Templates

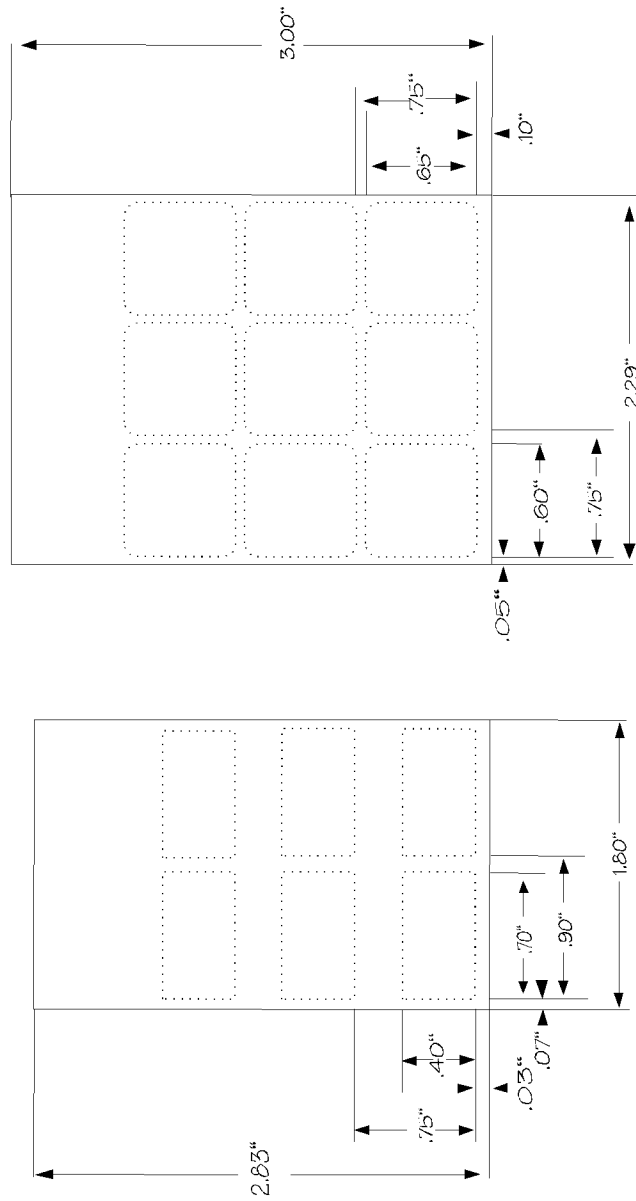

Specifications

Physical

- Recessed Mount Housing 6.6"L x 4.0"H x 1.25"D
- Cutout size for above 3.55"Hx5.8"L
- Panel Fasteners : Four, 6x32 threaded studs, shown above (on ends, symmetrical about center line)
- Weight : 10 ounces
- Colors : Dark gray with black panel
- Pushbutton dimensions : .65 inches square on .75 inch centers
- Pushbutton life : 1,000,000 switch cycles
- Lamp Colors Available : Red, Green, Yellow
- Lamp window size .7" x .4"

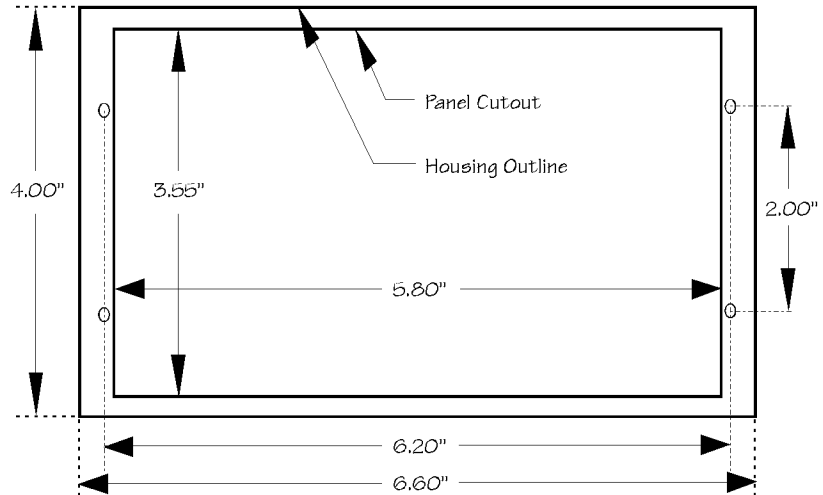

Electrical

- Power (all lamps on) : 8 - 30VDC @ 2.4VA
200 mA @ 12VDC 100 mA @ 24VDC
- Power on surge (see figure below) : 2A for 2 millisecond maximum

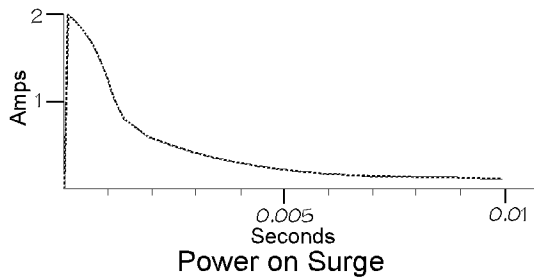

- Power connector : Pluggable terminal block, 2 position

Communications

- RS232 and RS422
- 4800 to 19200 baud
- Compatible with major PLC protocols
- 15 pin female 'D' shell connector (screw terminal adapter available)

Communications Failure Operation

Should the panel (when not selected for configuration) ever fail to communicate successfully for a period of 12 seconds, all lamps and inset LEDs will flash rapidly.

Panel Mounting Dimensions

Environmental

- Enclosure - NEMA 4 recessed mount
- Temperature - 0 to 50 C
- Humidity - 95% Non-condensing