

Programming Examples

In This Chapter. . . .

- Examples Using **DirectLogic** PLCs
 - DL05/105/DL205/D3–350/DL405 Examples
 - D3–330/340 Examples
 - Allen-Bradley™ SLC 5103–5105 and Micrologix Examples
 - Troubleshooting
-

Examples Using *Direct*LOGIC PLCs

Register Usage

The OP-WINEDIT configuration software allows you to configure a panel to use a block of registers at a starting value that you define. For a DL05, DL105, DL205, D3-350 or DL405 CPU the recommended memory to use is the general purpose data words starting at V2000. For the 305 family (except the D3-350) the recommended memory is the registers beginning at R400. Any block of registers within the data word range can be used.

The first eleven PLC registers in the block used by the OP-640 panel are used for numeric information, and this makes them ideally suited for the general purpose data registers. The M+12 and M+13 registers use individual bits for pushbutton status and light control, making it better suited for the control relay register range of memory. The solution to this minor conflict is to define the base register address in general purpose data register memory and place a rung in your PLC program to copy the last register to a control relay register (we show you how to do this later).

The following table lists the data word registers for *Direct*LOGIC™ CPUs.

Data Word Registers for <i>Direct</i> LOGIC™ PLCs		
Family	CPU	Control Relay Registers
<i>Direct</i> LOGIC™ DL05	D0-05	V1200-V7377
<i>Direct</i> LOGIC™ DL105	F1-130	V2000-V2377
<i>Direct</i> LOGIC™ DL205	D2-230	V2000-V2377
	D2-240	V2000-V3777
	D2-250	V1400-V7377 and V10000-V17777
<i>Direct</i> LOGIC™ DL305	D3-330/D3-330P	R400-R563
	D3-340	R400-R563 and R700-R767
	D3-350	V1400-V7377 and V10000-V17777
<i>Direct</i> LOGIC™ DL405	D4-430	V1400-V7377
	D4-440	V1400-V7377 and V10000-V17777
	D4-450	V1400-V7377 and V10000-V37777

DL05, DL105, DL205, D3-350 and DL405 Examples

Defining the Status Register

The following examples assume that the OP-640 is configured for a base address of V2000. When configuring the panel, use the configuration data and messages shown in the following figure.



NOTE: The Example Worksheet in Appendix A also has the configuration data and messages needed for these examples. The example shows how to plan your configurations.

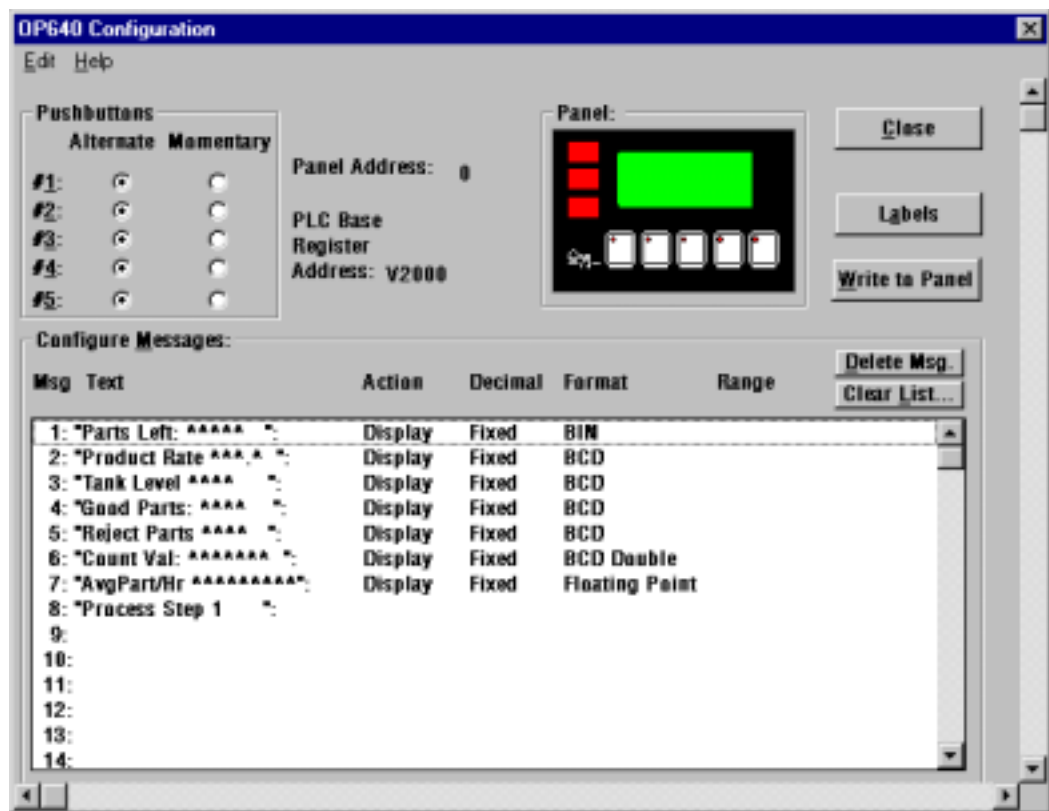

Place the following program rung in the program to copy the status register to memory location V40600 and copy V40601 to the control register. With this rung placed in the PLC program, the status and control bits will be control relays.

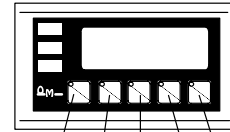
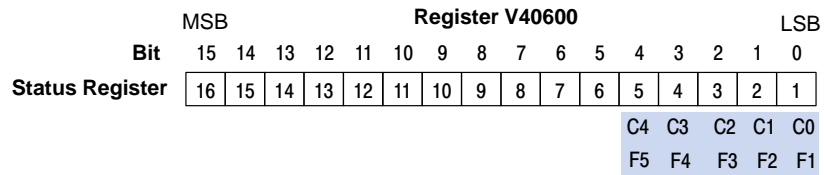
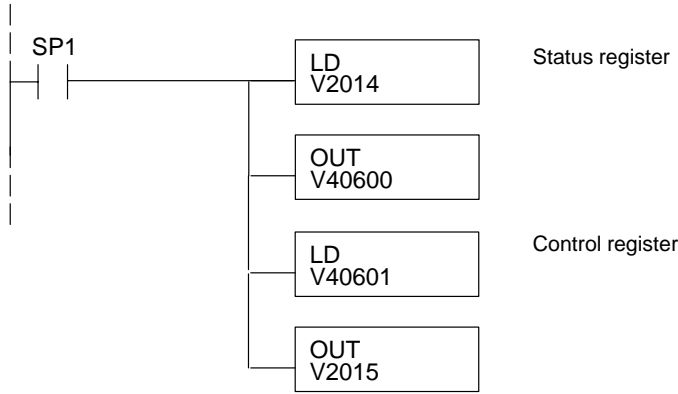

As you can see, control relays C0-C4 will be associated with pushbuttons F1-F5.

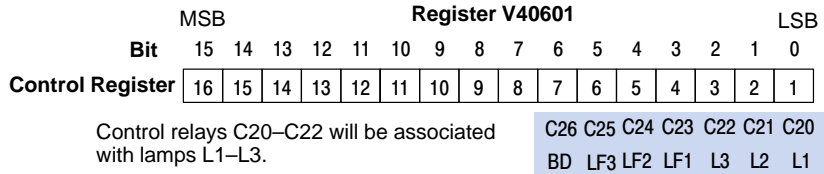

Control relays C20-C22 will be associated with lamps L1-L3.

Control relays C23-C25 will control L1-L3 flashing. C26 controls whether pushbuttons F1-F5 beep when pressed.

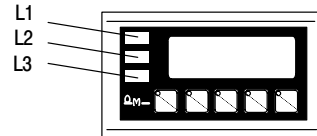

Using a Function Button

The five function buttons will appear as control relay coils in your program (assuming the register copy rung shown previously is in the program).

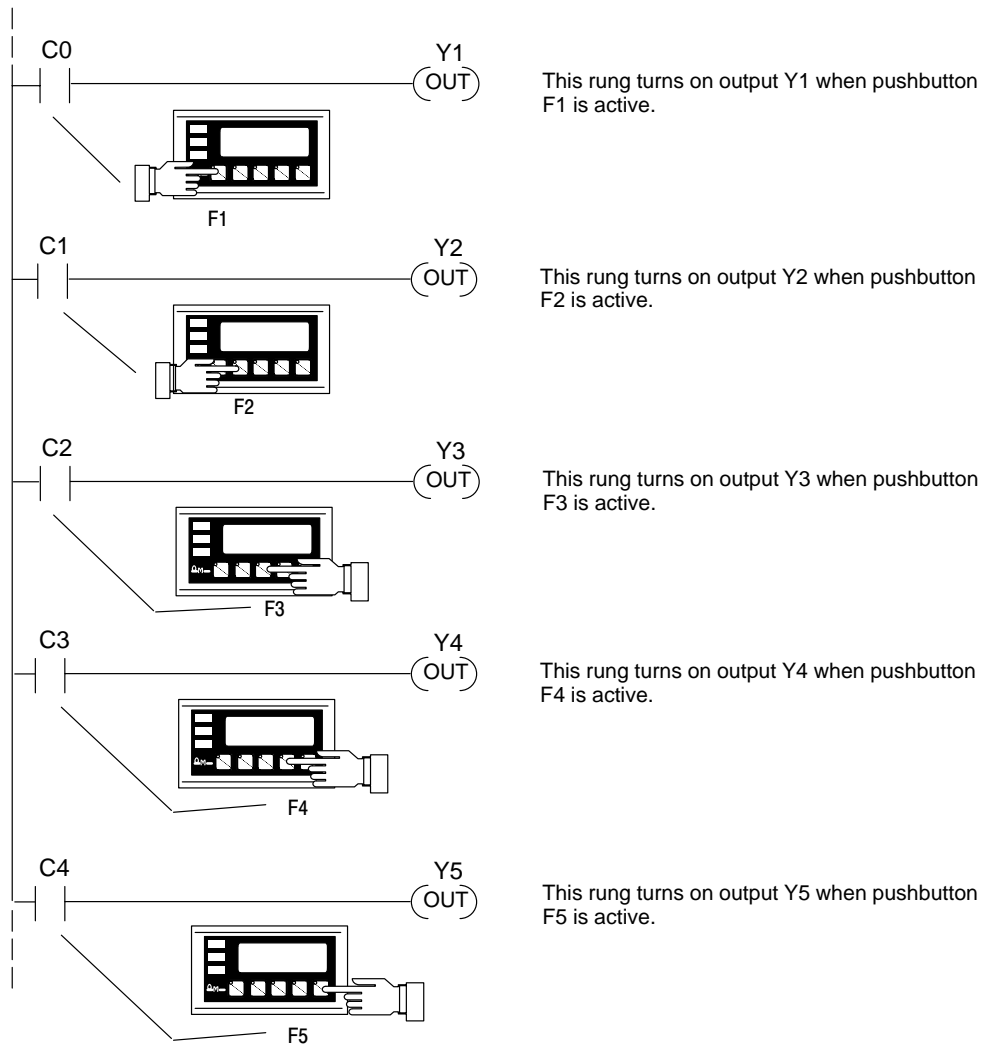

Lighting a Lamp

Lighting a lamp simply requires activating the control relay associated with the lamp. The following example will light the first lamp when relay C1 is on. Remember to place the register copy rung shown previously in the program.

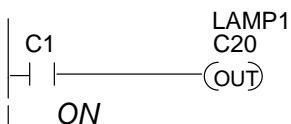

(DL250,DL350,DL 450 Only)

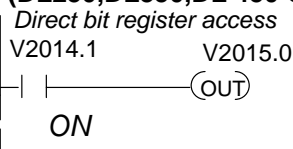

In this example, C1 represents the pushbutton No. 2 (F2) via the mapping process. When *alternating* pushbutton No. 2 is pressed internal Control Relay C20 is true and via mapping process Control register Bit 0 (L1 Lamp) is energized.

* Control Register (M+13) = V40601: C20 – C37

Flashing a Lamp

Flashing a lamp simply requires activating the lamp control relay (to turn the lamp on) and the flash control relay.

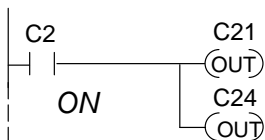

In this example, C2 represents the pushbutton No. 3 (F3) via the mapping process. When *alternating* pushbutton No. 3 is pressed internal Control Relay C21 and C24 are energized ON. This process manipulates Control Register bits 1 and 4 which controls lamp L2 on/off and L2 flashing (LF2).

*Control Register (M+13) = V40601: C20–C37

(DL250/D3–350/D4–450 Only)

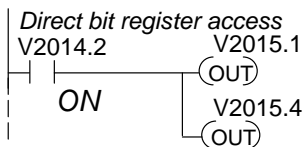

		Register V40600																
		MSB														LSB		
Bit		15	14	13	12	11	10	9	8	7	6	5	4	3	2	1	0	
Status Register		16	15	14	13	12	11	10	9	8	7	6	5	4	3	2	1	
														C4	C3	C2	C1	C0
														F5	F4	F3	F2	F1

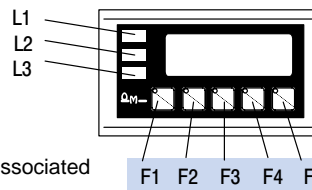

Control relays C0–C4 will be associated with pushbuttons F1–F5.

		Register V40601																		
		MSB														LSB				
Bit		15	14	13	12	11	10	9	8	7	6	5	4	3	2	1	0			
Control Register		16	15	14	13	12	11	10	9	8	7	6	5	4	3	2	1			
														C26	C25	C24	C23	C22	C21	C20
														BD	LF3	LF2	LF1	L3	L2	L1

Control relays C20–C22 will be associated with lamps L1–L3 and C23–C25 will control L1–L3 flashing. C26 controls whether pushbuttons F1–F5 beep when pressed.

Displaying Messages

The following example shows two messages being displayed. The example assumes that the messages shown earlier are entered, and shows two messages that will be displayed as long as C100 is on. The second line is displaying message #4 and the bottom line is displaying message #8. The top and third lines use data message display #140, which has been configured as a blank text message.

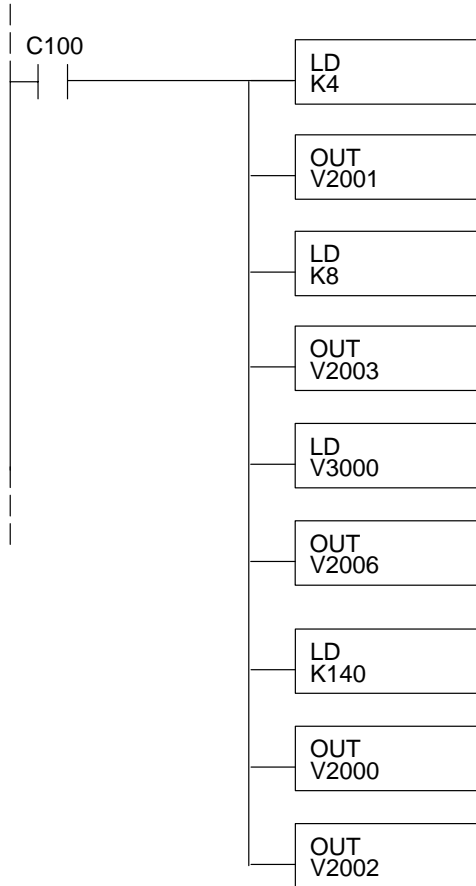

This selects message #4 to be displayed in the second line.

This selects message #8 to be displayed in the bottom line.

This puts data from V3000 (235 in this example) into the second line data field (^^^).

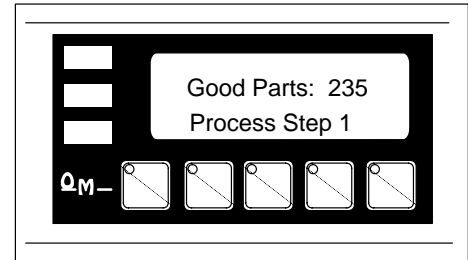

The last three instructions select message #140 (blank text) and loads it into both the top and third lines to blank those lines.

PLC Register	Register Function
V2000	Top line message selection
V2001	Second line message selection
V2002	Third line message selection
V2003	Bottom line message selection
V2004	Top line data
V2005	Top line data 2 (for long BCD and floating point numbers)
V2006	Second line data
V2007	Second line data 2 (for long BCD and floating point numbers)
V2010	Third line data
V2011	Third line data 2 (for long BCD and floating point numbers)
V2012	Bottom line data
V2013	Bottom line data 2 (for long BCD and floating point numbers)
V2014	Status register
V2015	Control register

Displaying Binary Numbers

This example is similar to the previous example, except that it uses a binary number in the top display. The top line uses data display message #1, which has been configured as a binary display message. The data for the top data field is number 56432 (from V2200). The third line is text message #8. The second and bottom lines use message #140 which has been configured as a blank text message.

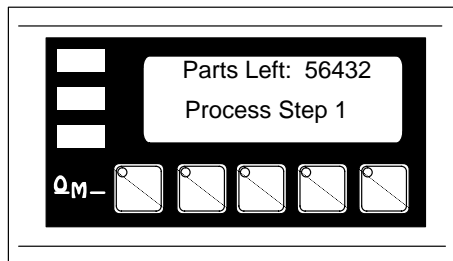
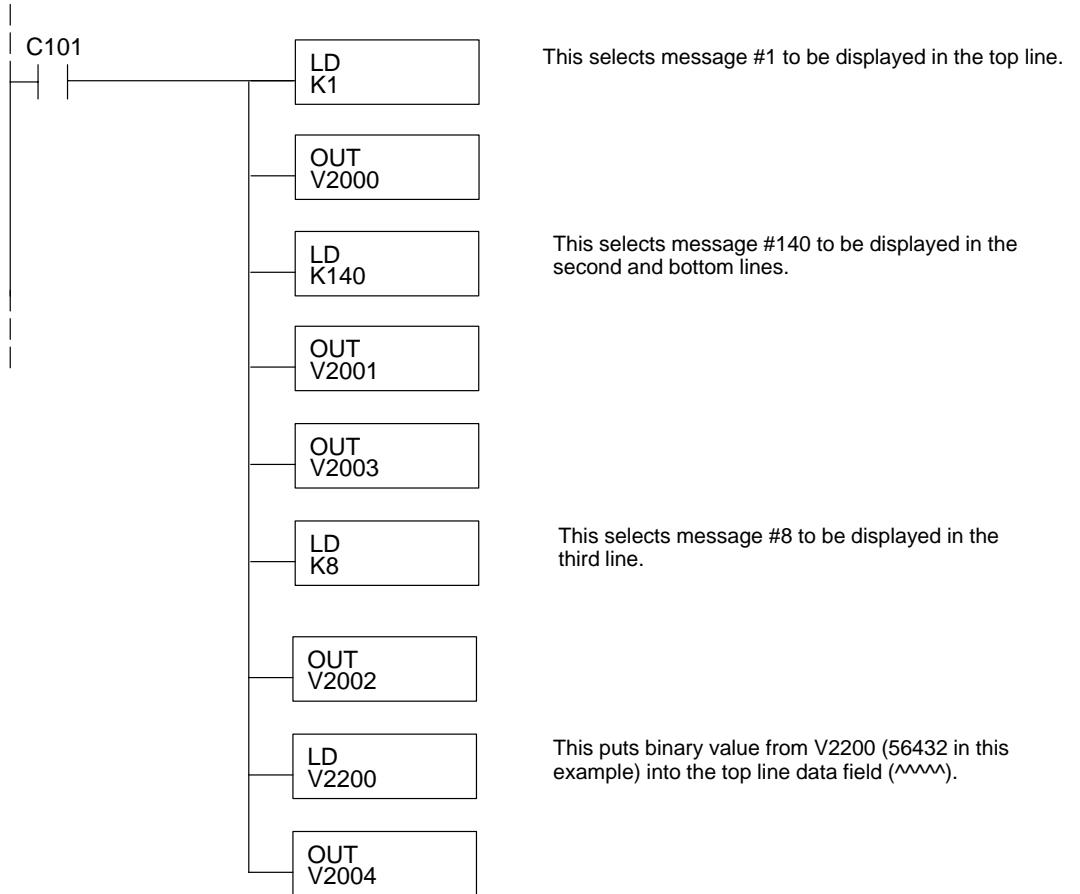

Displaying BCD Double Numbers

This example is similar to the previous example, except that it uses a BCD Double number in the bottom line display. The bottom line uses data display message #6, which has been configured as a BCD Double display message. The data for the bottom line data field is from V3002 and V3003. V3002 contains the four least significant digits while V3003 contains the four most significant digits. The top line is text message #8. The second line displays message #3. The data for the second line BCD message comes from register V2100. The third line uses message #140, which has been configured as a blank text message.

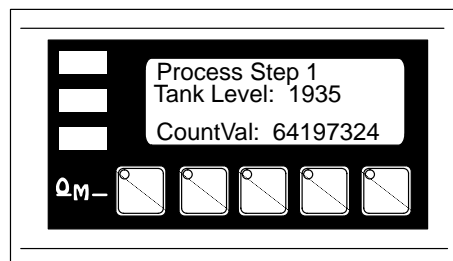
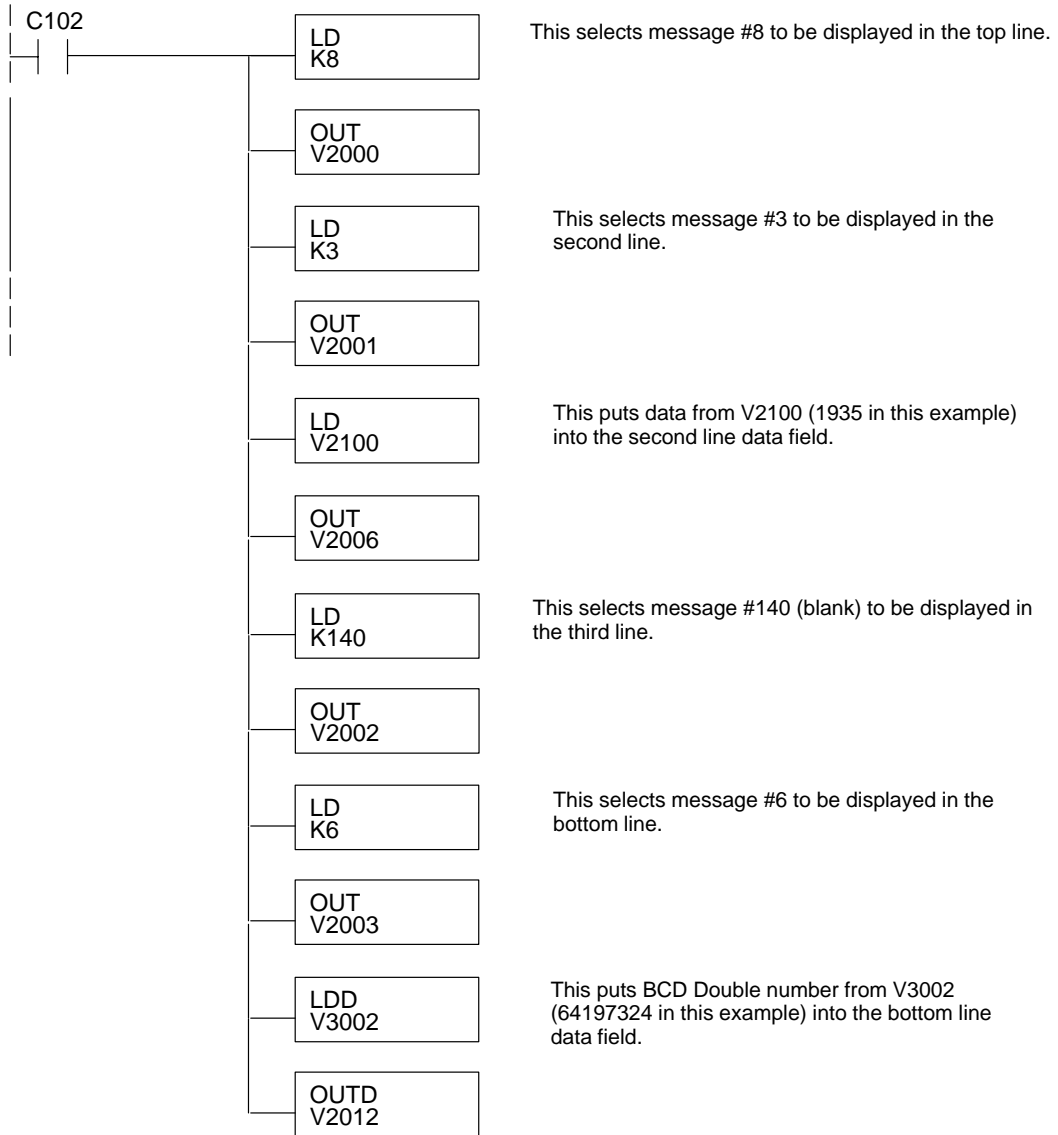

Displaying Floating Point Numbers Example 1

This example uses a floating point number in the third line display message. The third line uses data display message #7, which has been configured as a floating point display message. Since the data is a floating point number, it uses two 16-bit registers. The two registers have to be looked at together, not individually, for the data to be understandable. In this example, the data is a constant number (168932) which is loaded into the third line data display registers using an LDR (load real number) instruction. The top and bottom lines use message #140, which has been configured as a blank text message. The second line is text message #8.

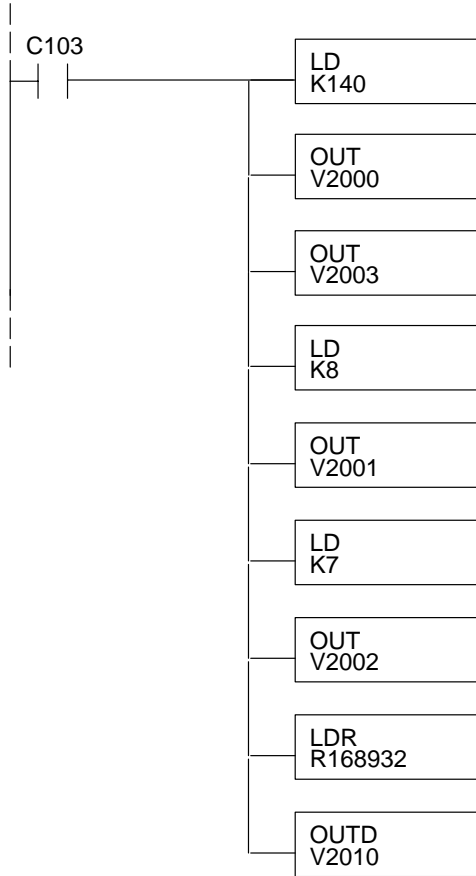

This selects message #140 (blank) to be displayed in the top and bottom lines.

This selects message #8 to be displayed in the second line.

This selects message #7 to be displayed in the third line.

This puts the floating point value 168932 into the third line data field. Notice that the displayed value is truncated.

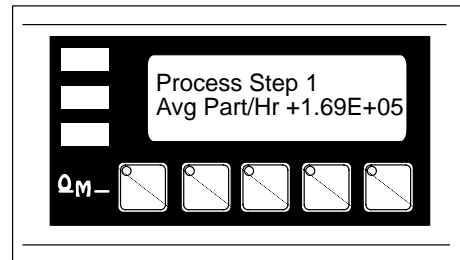

Displaying Floating Point Numbers Example 2

This example is similar to the previous one, except that it gets its value from two PLC registers instead of a constant value. The third line uses data display message #7, which has been configured as a floating point display message. Remember, floating point numbers require two 16-bit registers and they must be read together. In this example, the data is loaded from V3010 and V3011 using an LDR (load real number) instruction to the third line display registers V2010 and V2011. The top and bottom lines use message #140, which has been configured as a blank text message. The second line uses message #8, a text message.

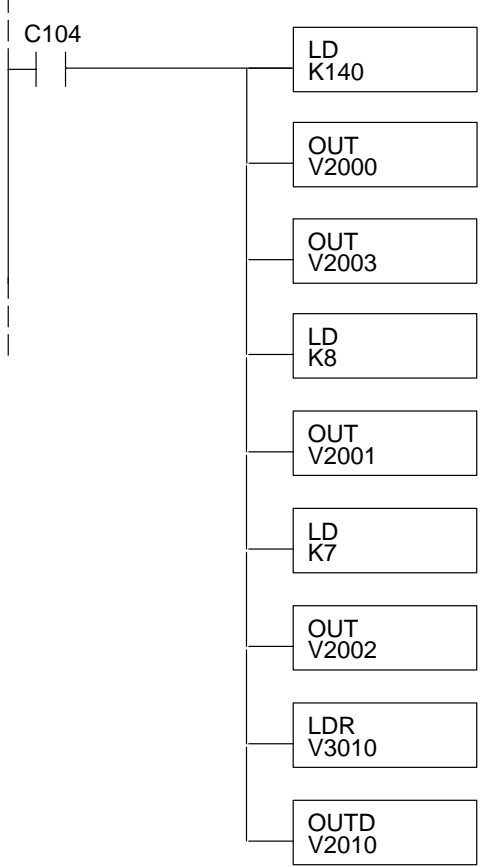

This selects message #140 (blank) to be displayed in the top and bottom lines.

This selects message #8 to be displayed in the second line.

This selects message #7 to be displayed in the third line.

This puts the floating point value from V3010 and V3011 into display registers V2010 and V2011.

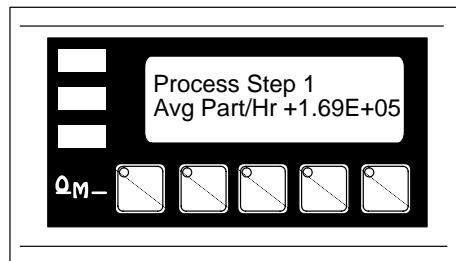

Example Using D3-330/340

Example

The following example assumes that the OP-640 is configured for a base address of R400/R401. When configuring the panel, enter the messages shown in the previous section for the DL05, DL105, DL205, D3-350 and DL405 examples.

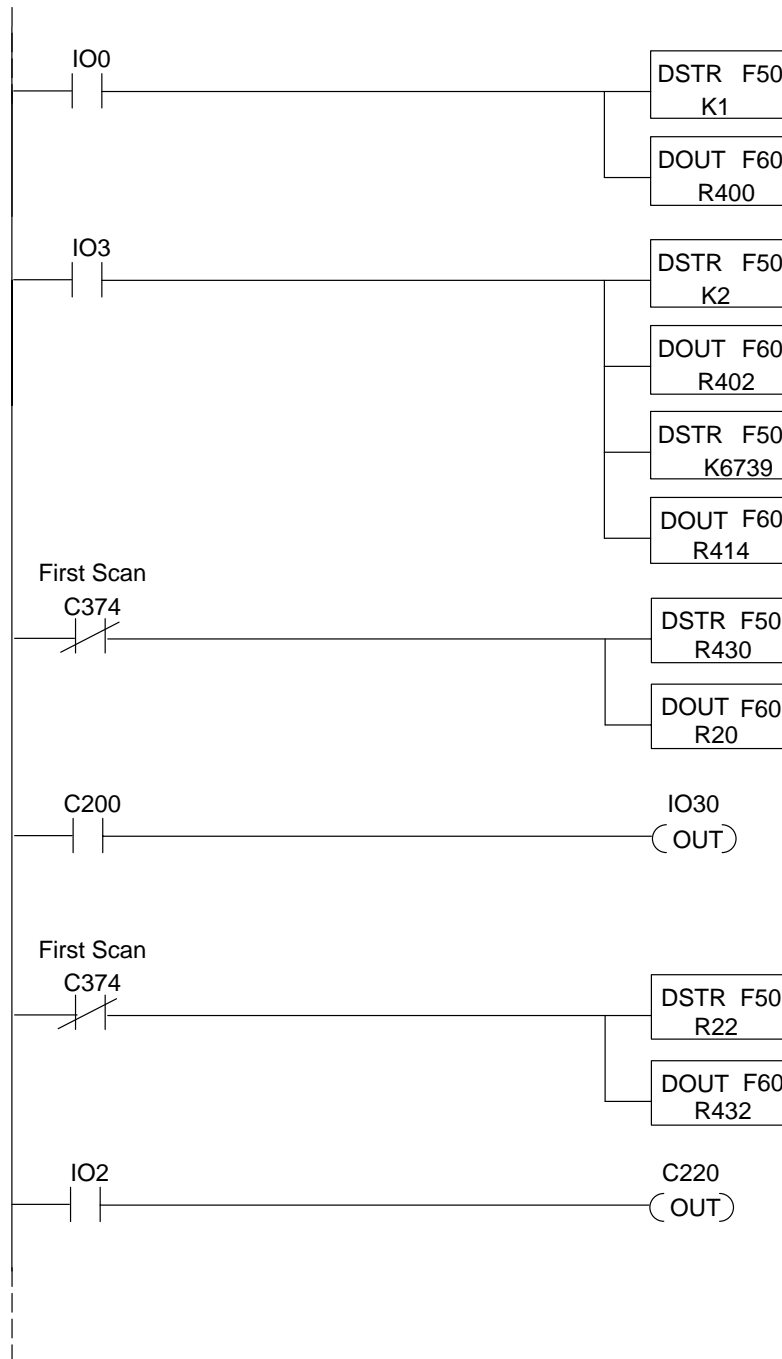

Displaying Messages

This rung displays message #1 in the top display line.

This rung displays message #2 and BCD data in the second display line.

Second line message.

Second line data.

This rung remaps the status register (pushbuttons) into control relays R20/21.

Pushbutton Example

This rung allows pushbutton F1 to turn on output IO30.

This rung remaps control relays R22/23 into the control register (lamps).

Lamp Example

This rung allows input IO2 to turn on lamp L1.

Flashing a Lamp Flashing a lamp simply requires activating the control relay to turn on the lamp and the flash control relay. This example will flash lamp L1 when input I:2/12 is active.

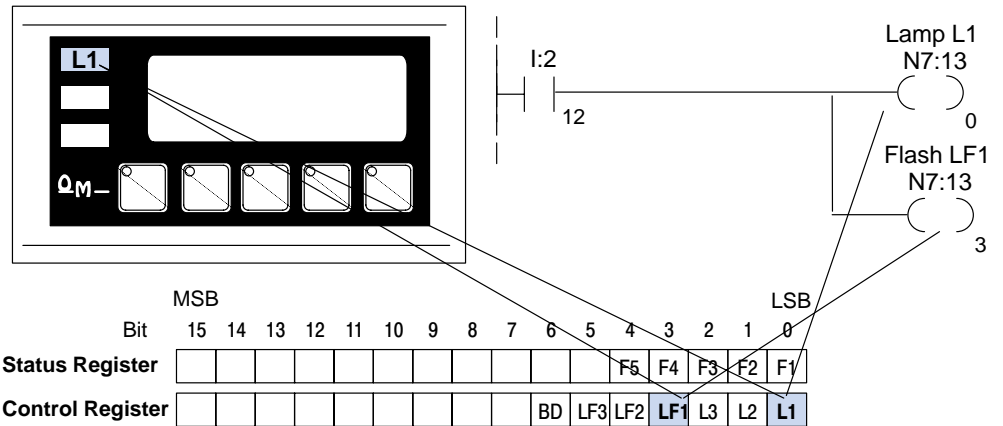

Using a Function Button The five function buttons will appear as control relay coils in your program. This example turns on lamp L3 (N7:13/2) when button F4 (N7:12/3) is active.

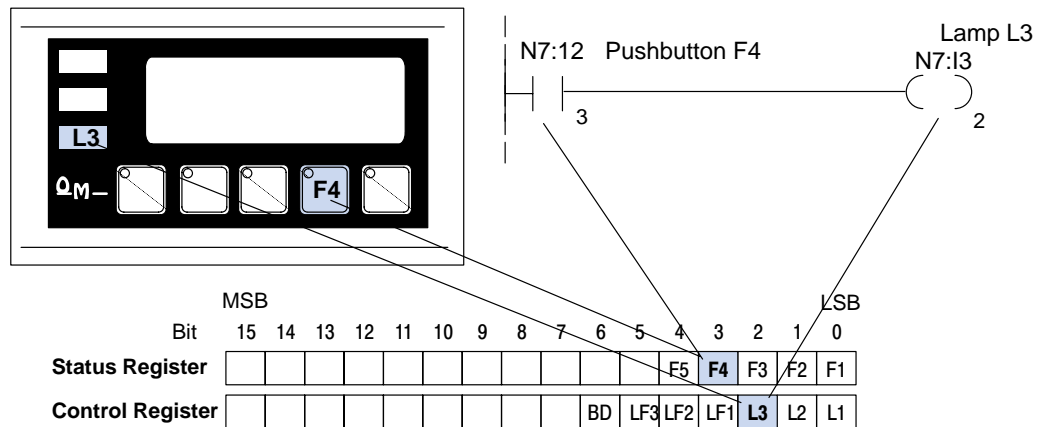

Displaying Messages

The following example uses the configuration shown below.

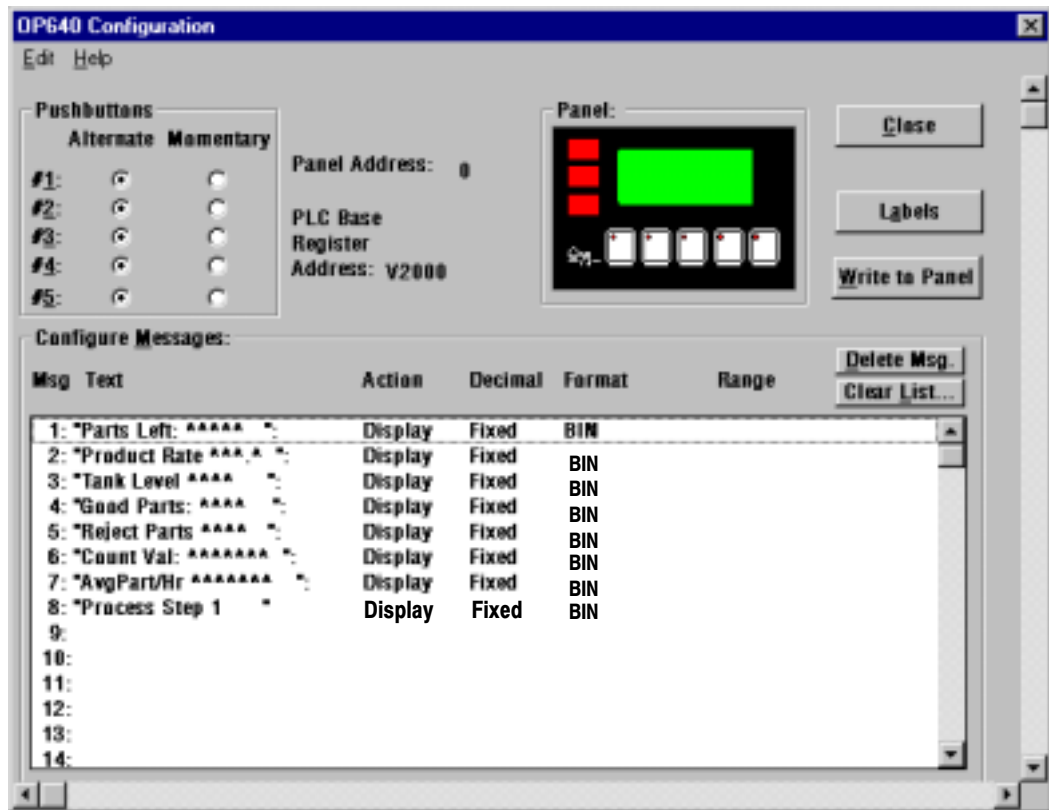

Displaying Messages Example

The second line is displaying BCD message #4. The data for the data field which is displayed in the second line is from location N7:54. The bottom line is displaying text message #8. The top and third lines use data display message #140, which has been configured as a blank text message.

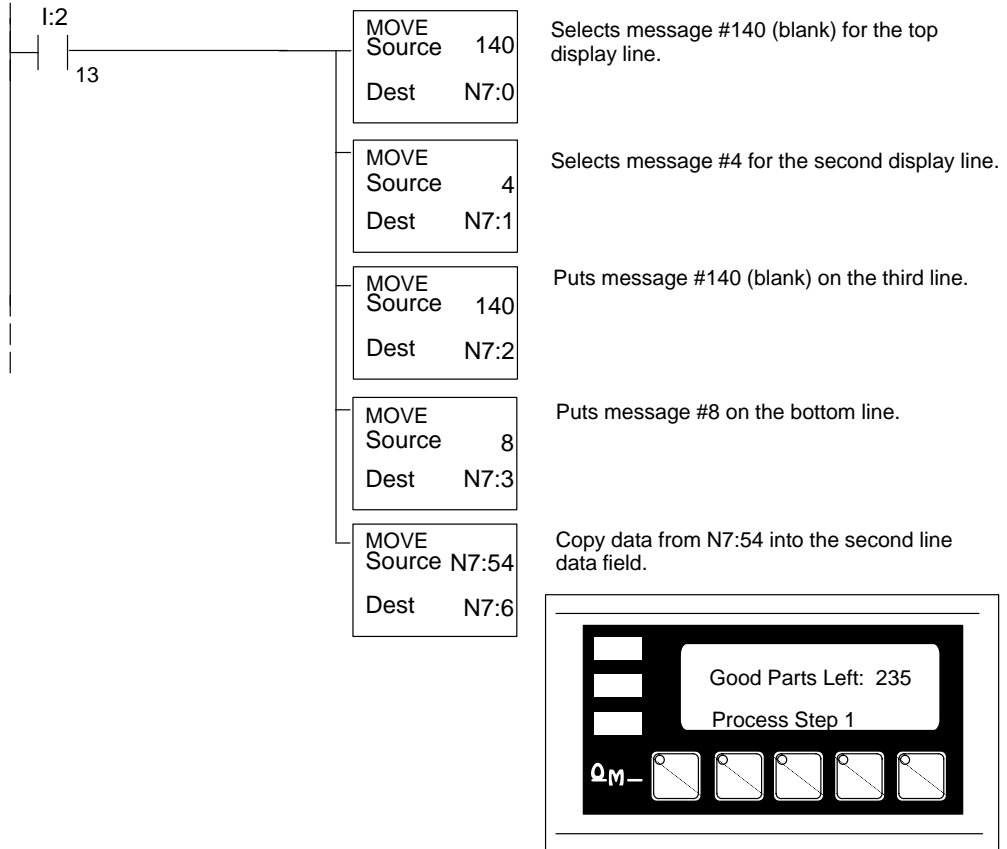

Example Address		Function
N7:0	M+0	Top line message selection
N7:1	M+1	Second line message selection
N7:2	M+2	Third line message selection
N7:3	M+3	Bottom line message selection
N7:4	M+4	Top line data
N7:5	M+5	Not used with A-B (see Note)
N7:6	M+6	Second line data
N7:7	M+7	Not used with A-B (see Note)
N7:8	M+8	Third line data
N7:9	M+9	Bottom line data
N7:10	M+10	Top line data
N7:11	M+11	Not used with A-B (see Note)
N7:12	M+12 Status	
N7:13	M+13 Control	

NOTE: While the OP-640 will display BCD Double and Floating Point numbers, it does not support these functions when used with A-B PLCs.



Displaying Binary Numbers

This example is similar to the previous example, except that it uses a binary number in the top line display. The top line uses data display message #1, which has been configured as a Binary display message. The data for the top line data field is a constant number, 56432 (DC70 Hexadecimal). The third line is text message #8. The second and bottom lines use text message #140, which has been configured as a blank text message.

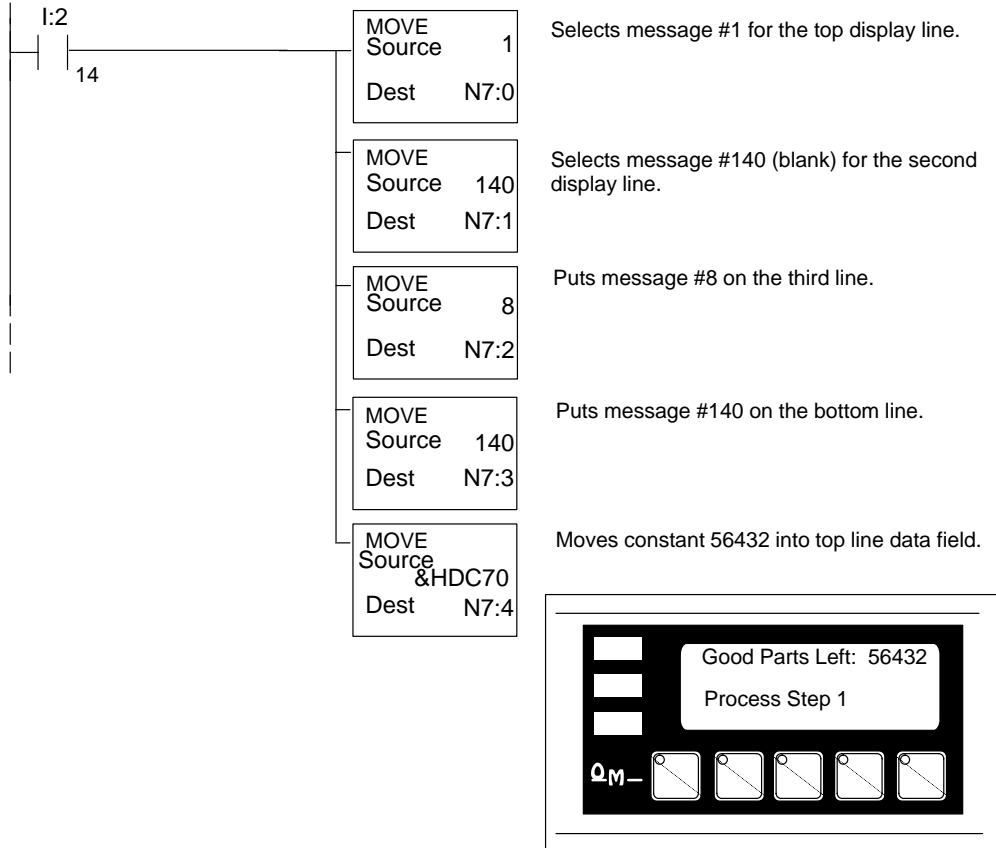

Example Address		Function
N7:0	M+0	Top line message selection
N7:1	M+1	Second line message selection
N7:2	M+2	Third line message selection
N7:3	M+3	Bottom line message selection
N7:4	M+4	Top line data
N7:5	M+5	Not used with A-B (see Note)
N7:6	M+6	Second line data
N7:7	M+7	Not used with A-B (see Note)
N78	M+8	Third line data
N7:9	M+9	Bottom line data
N7:10	M+10	Top line data
N711	M+11	Not used with A-B (see Note)
N7:12	M+12 Status	F5 F4 F3 F2 F1
N7:13	M+13 Control	BD L3F L2F L1F L3 L2 L1