

## Output Specifications

Outputs per Module	8 relays (non-latching)	
Commons per Module	8 (isolated)	
Operating Voltage Range (Tolerance)	(CE)	6.25-24 VDC (-15% / +20%) 6-240 VAC (-15% / +10%)
	(UL)	5-30 VDC (-0% / +10%) 5-240 VAC (-0% / +10%)
Output Type	4 Form C (SPDT-NO/NC), 4 Form A (SPST-NO)	
AC Frequency	47-63 Hz	
On Voltage Drop	Minimal (90 mV max for fuse at 10A)	
Max Output Current @ Temperature (Resistive)*	6.3A at 23°C, 5.0A at 60°C For both AC and DC	
Maximum Leakage Current	Minimal (5 µA for TVS diode)	
Minimum Load	10 mA @ 5 VDC	
Maximum Inrush Current	12A	
External DC Required	None	
OFF to ON Response	10 ms	
ON to OFF Response	5 ms (Excluding NO bounce)	
Terminal Type (not included)	20 position removable terminal block	
Status Indicators	Logic side	
Fuses	6.3A user replaceable fuse per common For replacement, order P3-FUSE-2 (5/Pkg.)	
Dielectric Strength (Between normally open and normally closed contacts on the same relay)	1500 VAC @ 1 min logic to output and isolated output to output, 750 VAC @ 1 min between contacts on same relay (Same as 1800 VAC @ 1 sec and 900 VAC @ 1 sec)	
Transient Voltage Suppression (Bi-directional TVS diode)	482V clamp at 1.25A peak pulse current	
Mechanical Life Expectancy	>100,000 at 30 operations per minute	

\*Rating is for a normally-open contact. Normally-closed contacts have 1/2 the current handling capability.

**WARNING:** Explosion hazard – Substitution of components may impair suitability for Class I, Division 2.

Warranty: Thirty-day money-back guarantee. Two-year limited replacement. (See [www.productivitypac.com](http://www.productivitypac.com) for details).

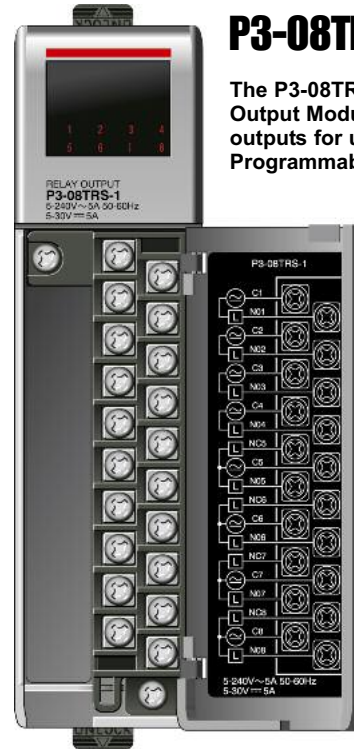

## P3-08TRS-1 Relay Output

The P3-08TRS-1 High-Current Isolated Relay Output Module provides eight 5 amp relay outputs for use with the Productivity3000 Programmable Automation Controller.

Derating Chart	1
Output Specifications	1
Module Installation Procedure	2
Terminal Block Removal	2
Hot Swap Information	2
Wiring Options	3
Schematic and Wiring Diagram	3
Replacement Fuses	3
Warning	4
Typical Relay Life	4
Removable Terminal Block Specifications	4
General Specifications	4

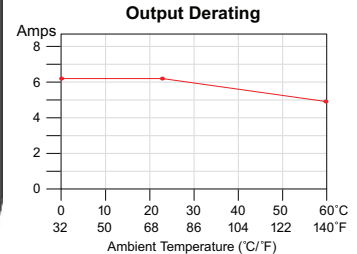

All 8 outputs on, 100% duty cycle allowed.

**Terminal Block sold separately,  
Terminal Block Cover included (see wiring options on page 3).**

## Module Installation Procedure

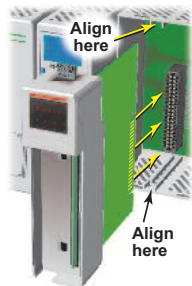

**WARNING:** Do not apply field power until the following steps are completed. See hot-swapping procedure for exceptions.

**Step One:** Align circuit card with slot and press firmly to seat module into connector.

**Step Two:** Pull top and bottom locking tabs toward module face. Click indicates lock is engaged.

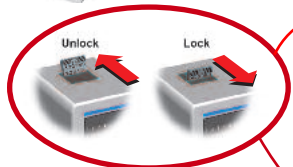

**Step Three:** Attach field wiring using optional terminal block or ZIPLink wiring system and install cover.



To install or remove terminal block cover, press middle to flex cover.



**WARNING:** Explosion hazard – Do not connect or disconnect connectors or operate switches while circuit is live unless the area is known to be non-hazardous. Do not hot-swap modules unless the area is known to be non-hazardous.

## Terminal Block Removal

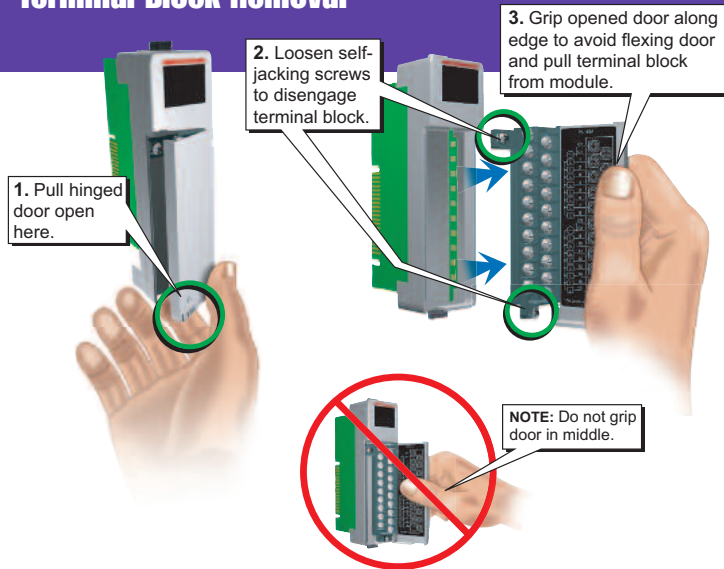







### Important Hot-Swap Information

#### The Productivity3000 PAC supports hot-swap!

Individual modules, expansion bases, and entire remote base groups can be taken offline, removed, and replaced while the rest of the PAC system continues controlling your process. Before attempting to use the hot-swap feature, be sure to read the hot-swap topic in the programming software's help file or our online documentation at [AutomationDirect.com](http://AutomationDirect.com) for details on how to plan your installation for use of this powerful feature.

## Wiring Options

<p><b>1</b> ZIPLink Connection System Cable + ZIPLink Module = Complete System</p>  <p><b>ZIPLink pre-wired terminal block cables</b></p> <p>0.5m (1.6FT) cable ZL-P3-CBL20 1.0m (3.3FT) cable ZL-P3-CBL20-1 2.0m (6.6FT) cable ZL-P3-CBL20-2</p>  <p><b>ZIPLink Modules</b></p> <p>Feed through ZL-RTB20</p>	
<p><b>2</b> Terminal Block with pigtail cable</p>  <p>0.5m (1.6FT) cable ZL-P3-CBL20-P 1.0m (3.3FT) cable ZL-P3-CBL20-1P 2.0m (6.6FT) cable ZL-P3-CBL20-2P</p>	
<p><b>3</b> Terminal Block only</p>  <p>P3-RTB (Quantity 1)</p>	



**CAUTION:** The ZIPLink Wiring System is rated at 2 amps per I/O point. Therefore the P3-08TRS-1 relay outputs are derated to 2 amps per point when using the ZIPLink Wiring System.

## Schematic and Wiring Diagrams

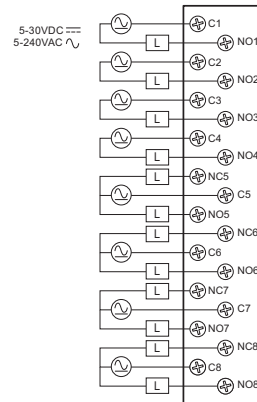
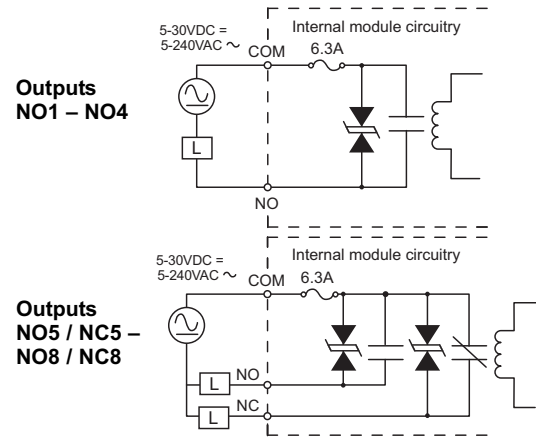

### Replaceable Fuses

**Order Part Number P3-FUSE-2**  
(Qty. 5/Pkg.) One spare included with this module.

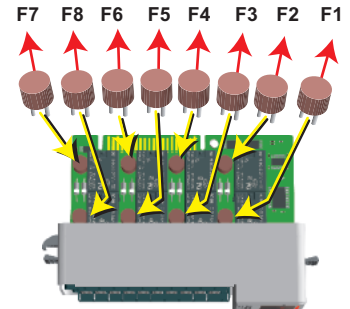

**WARNING:** To minimize the risk of potential safety problems, you should follow all applicable local and national codes that regulate the installation and operation of your equipment. These codes vary from area to area and it is your responsibility to determine which codes should be followed, and to verify that the equipment, installation, and operation are in compliance with the latest revision of these codes.

**Equipment damage or serious injury to personnel can result from the failure to follow all applicable codes and standards. We do not guarantee the products described in this publication are suitable for your particular application, nor do we assume any responsibility for your product design, installation, or operation.**

If you have any questions concerning the installation or operation of this equipment, or if you need additional information, please call Technical Support at 770-844-4200.

This publication is based on information that was available at the time it was printed. At AutomationDirect.com® we constantly strive to improve our products and services, so we reserve the right to make changes to the products and/or publications at any time without notice and without any obligation. This publication may also discuss features that may not be available in certain revisions of the product.

## Typical Relay Life\*

Voltage & Type of Load	Operating Current	Operations
24VDC Resistive	6.3A	600,000
24VDC Solenoid	0.2A	1,000,000
120VAC Resistive	6.3A	600,000
120VAC Resistive	3A	1,000,000
120VAC Solenoid	0.5A	500,000
240VAC Resistive	6.3A	450,000
240VAC Resistive	3A	600,000
1/4 HP Motor	1.5 x FLA (motor)	30,000

\*Ratings are for normally-open contacts. Normally-closed contacts have 1/2 the current handling capability.

## Removable Terminal Block Specifications

Number of Positions	20 screw terminals
Wire Range	22-14 AWG (0.324 to 2.08 sq. mm) solid / stranded conductor 3/64 in. (1.2 mm) insulation maximum "USE COPPER CONDUCTORS , 60°C" or equivalent.
Screw Driver Width	1/4 inch (6.5 mm) maximum
Screw Size	M3 size
Screw Torque	Field terminals – 7- 9 in./lb (.0882 - 1.02 Nm) Self-jacking Screws – 2.7 - 3.6 in./lb (0.3 - 0.4 Nm). Do not overtighten screws when installing terminal block.

## General Specifications

Operating Temperature	0° to 60°C (32° to 140°F),
Storage Temperature	-20° to 70°C (-4° to 158°F)
Humidity	5 to 95% (non-condensing)
Environmental Air	No corrosive gases permitted
Vibration	IEC60068-2-6 (Test Fc)
Shock	IEC60068-2-27 (Test Ea)
Field to Logic Side Isolation	1800VAC applied for 1 second
Insulation Resistance	>10MΩ @ 500 VDC
Heat Dissipation	3W
Enclosure Type	Open Equipment
Agency Approvals	UL508 file E157382, Canada & USA UL1604 file E200031, Canada & USA CE (EN61131-2*)  This equipment is suitable for use in Class 1, Division 2, Groups A, B, C and D or non-hazardous locations only.
Module Keying to Backplane	Electronic
Module Location	Any I/O slot in any local, expansion, or remote base in a Productivity3000 System.
Field Wiring	Removable Terminal Block (not included). Use ZIPLink Wiring System or optional terminal block. See "Wiring Options" on page 3.
EU Directive	See the "EU Directive" topic in the Productivity3000 Help File. Information can also be obtained at: <a href="http://www.productivitypac.com">www.productivitypac.com</a>
Terminal Type (not included)	20 position removable terminal block
Weight	286g (10.08 oz)

\*Meets EMC and Safety requirements. See the D.O.C. for details.

Document Name	Edition/Revision	Date
P3-08TRS-1-M	1st Ed.	10/26/2009

Copyright 2009, AutomationDirect.com Incorporated/All Rights Reserved Worldwide