

RHINO PSP SERIES DC - DC CONVERTERS



INSTALLATION INSTRUCTIONS PSP Series DC - DC Converters

Input Specifications

Input Specifications								
Part Number	Input Voltage Range	Input Current		Power Consumption		Startup Voltage	Undervoltage Shut-down	Efficiency (Typical)
		@ $V_{in} = 12\text{ VDC}$		@ $V_{in} = 12\text{ VDC}$				
		$I_{out} = 0\%$	$I_{out} = 100\%$	$I_{out} = 0\%$	$I_{out} = 100\%$			
PSP**-DC12-*	9.5 to 18.0 VDC	80mA max	2.5A max	0.96 watt typical	30 watt typical	8.4 VDC	7.6 VDC	86%
		@ $V_{in} = 24\text{ VDC}$	@ $V_{in} = 48\text{ VDC}$	@ $V_{in} = 24\text{ VDC}$	@ $V_{in} = 48\text{ VDC}$			
		$I_{out} = 0\%/100\%$	$I_{out} = 0\%/100\%$	$I_{out} = 0\%/100\%$	$I_{out} = 0\%/100\%$			
PSP**-DC24-*	18 to 75 VDC	80mA max/1.3A max	60mA/0.7A max	1.92W/31.2W typical	2.88W/33.6W typical	17.2 VDC	15.7 VDC	86%

Output Specifications

Output Specifications								
Part Number	Output Voltage	Output Voltage Adj. Range	Output Current (max.)	Ripple/Noise	Output Voltage Regulation*	Overvoltage Protection, Trigger Point	Short Circuit Protection	MTBF (IEC 1709 @ 25°C)
PSP24-DC12-1	24 VDC	24.0 - 28.0 VDC	1 A	<50mV peak to peak	±0.5 % max	<42 V	Current limited at 110% typical	2.5 million hours
PSP05-DC24-5	5 VDC	5.0 - 5.25 VDC	5 A			<6.5 V		
PSP12-DC24-2	12 VDC	12.0 - 15.0 VDC	2 A			<24 V		
PSP24-DC24-1	24 VDC	24.0 - 28.0 VDC	1 A			<42 V		

*Note: Input variation $V_{in\ min}$ to $V_{in\ max}$ and load variation 0 to 100%

General Specifications

General Specifications	
Temperature	Operating: -10°C to 70°C max (14°F to 158°F max); Storage (non-operating): -25°C to 85°C max, (-13°F to 185°F max); Derating: 1.5%/C above 50°C (122°F)
Humidity (Non-condensing)	95 % relative humidity max.
Temperature Coefficient	0.02 %/C
Switching Frequency	55 - 180 kHz depending on load (frequency modulation)
Isolation Voltage (1 min.) - Input/Output	1500 VDC
Reliability, Calculated MTBF @ 25°C	>2.5 Mio h (according to IEC-1709)
Safety Standards	IEC 60950-1, EN 60950-1 (output SELV), UL/cUL 60950-1, EN 60204
Electromagnetic Compatibility (EMC)	Emissions: EN 61000-6-3; Immunity: EN 61000-6-2
Safety Class	Degree of protection class 1
Parallel Operation	No parallel operation
Connections	Screw type plug-in connector (standard). Recommended tightening torque 0.5 to 0.7 Nm (4.5 to 6.2 lb.in)
Wiring	0.21mm ² - 3.16mm ² (AWG 24 to AWG 12)
Enclosure Rating	IP 20 (IEC 60529)
Enclosure Material	Plastic FR2010-110C (UL 94V-0 rated)
Mounting	DIN rails per EN 50022-35x15/7.5 (snap-on with self-locking spring) bracket for wall/chassis mount included
Agency Approvals	UL/cUL 508 Listed, File E197592, CE

Note: All specifications valid at nominal input voltage, full load and +25°C after warm-up time unless otherwise stated.

Dimensions and Wiring

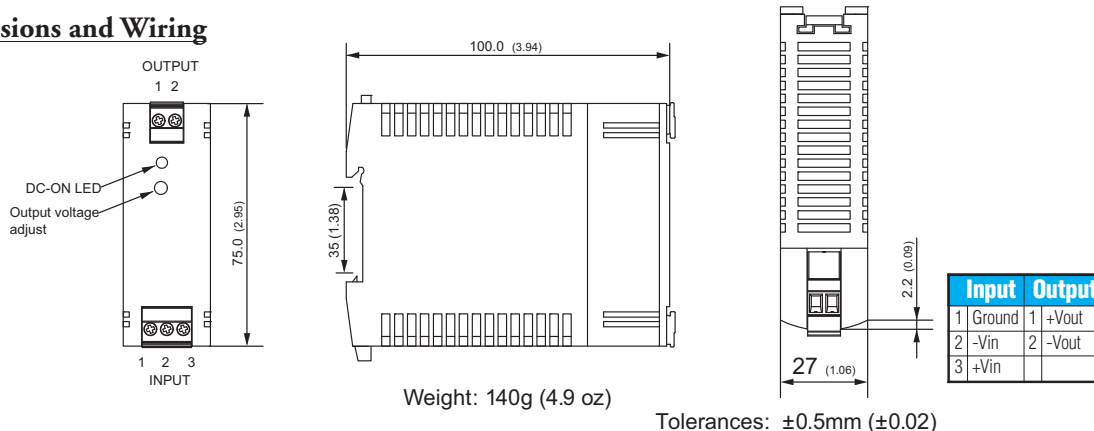

RHINO PSP SERIES DC - DC CONVERTERS



Safety Instructions:

- Read these instructions carefully and completely before installation. These instructions cannot cover every possible installation, operation or maintenance situation. Further information can be obtained from the product datasheets, which can be downloaded, from the Internet at <http://www.automationdirect.com>.
- These converters are constructed in accordance with the safety requirements of IEC/EN60950-1, UL60950-1 and UL508. They are approved (UL and cUL) in accordance with UL508, and fulfill the requirements of the Low Voltage Directive (LVD).
- Before any installation, maintenance or modification work, be sure that the main switch is switched off and prevented from being switched on again. Non-observance, touching of any live components or improper handling of this power supply can result in death, severe personal injury or substantial property damage. Proper and safe operation is dependent on proper storage, handling, installation and operation.
- Compliance with the relevant national regulations (in the USA, Europe and other countries) is required. Before operation is started the following conditions must be met:
 - Connection to the source in compliance with national regulations.
 - Use of stranded wires, all strands must be fastened in the terminal blocks.
 - Input cables must be sufficiently fused.
 - Degree of protection I to IEC536. The non-fused protective earth connection must be connected to the FG terminal (Protection Class I).
 - All output wires must be rated for the power supply output current and must be connected with the correct polarity.
 - Sufficient cooling must be assured.
- **Never work on the DC/DC converter if power is connected!** There is risk of electric arcs and electrical shock, which can cause death, severe personal injury or substantial property damage.
- **Warning:** Hazardous voltages and components storing a very substantial amount of energy are present in this power supply during normal operating conditions. However, these are inaccessible. Improper handling may result in an electric shock or serious burns! *Do not open the converter until at least 5 minutes after it has been disconnected from the input source on all poles.*
- Allow only trained personnel to open the converter.
- Do not insert any objects into the converter. Actuate the output voltage adjustment potentiometer by using an insulated screwdriver only.
- Keep away from fire and water.

Installation Instructions:

- This converter is designed for professional indoor systems. The converter must not be accessible while in operation. Allow installation and service by qualified personnel only.
- Do not operate without PE connection! To comply with EMC and safety standards (CE mark, approvals) the power supply is to be operated only if PE terminal is connected to the non-fused ground conductor.
- Mount unit for optimal cooling performance. **Do not cover any ventilation holes.** Please allow minimum free space of and 50mm (2") above and below the converter for air convection. Observe power derating.
- The internal fuse is not accessible, as it is not to be replaced by the user. If this internal fuse has blown, the converter most likely has an internal defect and, for safety reasons, must be discarded, or, if under warranty, returned. In case this internal fuse has to be replaced in the field, replace only with same type and rating of fuse for continued protection against risk of fire.
- **Recycling:** The unit contains elements that are suitable for recycling, **and** components that need special disposal. Please make sure that the power supply is recycled in an environmentally friendly way at the end of its service life.
- **Warning:** To minimize the risk of potential safety problems, follow all applicable local and national codes that regulate the installation and operation of your equipment. These codes vary from area to area and it is your responsibility to determine which codes should be followed and to verify that the equipment, installation and operation are in compliance with the latest revision of these codes.
- Equipment damage or serious injury to personnel can result from the failure to follow all applicable codes and standards. We do not guarantee the products described in this publication to be suitable for your particular application, nor do we assume any responsibility for your product design, installation or operations.
- If you have any questions concerning the installation or operation of this equipment, or if you need additional information, please call us at 770-844-4200.
- This publication is based on information that was available at the time it was printed. At **AutomationDirect.com**[®] we constantly strive to improve our products and services, so we reserve the right to make changes to the products and/or publications at any time without notice and without any obligation. This publication may also discuss features that may not be available in certain revisions of the product.

To Install

1. Read and follow Safety and Installation instructions.
2. Hook top of converter's DIN rail clip on DIN rail.
3. Push down tab on top of converter to open DIN rail clip.
4. Rotate converter into DIN rail and release tab.
5. Verify the DIN rail clip is securely fastened on DIN rail.
6. Connect wires as indicated on converter.

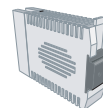

The unit can be mounted on a chassis or wall using the included mounting bracket.