

**FOR HITACHI INVERTER**

**SJ-FB (Feed-Back Board)**

# **INSTRUCTION MANUAL**

Thank you for purchasing the SJ-FB (HITACHI FEED-BACK BOARD). This manual explains the operation of the feed-back board for use with Hitachi SJ300 series inverters. Please read this manual thoroughly, along with the SJ300 Inverter Instruction Manual, for proper installation, setup, and maintenance. Keep this manual for future reference.

**HITACHI**

**NB616X**

# SAFETY

To get best performance with **SJ-FB (Feedback Board)**, read this manual and all of the warning sign attached to the inverter carefully before installation and operation, and follow the instructions exactly. Keep this manual handy for your quick reference.

## Definitions and Symbols

A safety instruction (message) is given with a hazard alert symbol and a signal word;

**WARNING** or **CAUTION**. Each signal word has the following meaning throughout this manual.



This symbol means hazardous high voltage. It used to call your attention to items or operations that could be dangerous to your and/or other persons operating this equipment.

Read these messages and follow these instructions carefully.



This is the "Safety Alert Symbol." This symbol is used to call your attention to items or operations that could be dangerous to your and/or other persons operating this equipment. Read the messages and follow these instructions carefully.



**WARNING**

### **WARNING**

Indicates a potentially hazardous situation which, if not avoided, can result in serious injury or death.



**CAUTION**

### **CAUTION**

Indicates a potentially hazardous situation which, if not avoided, can result in minor to moderate injury, or serious damage of product.

The matters described under  **CAUTION** may, if not avoided, lead to serious results depending on the situation. Important matters are described in **CAUTION** ( as well as **WARNING** ), so be sure to observe them.

**NOTE**

### **NOTE**

Notes indicate an area or subject of special merit, emphasizing either the product's capabilities or common errors in operation or maintenance.



**HAZARDOUS HIGH VOLTAGE**

Motor control equipment and electronic controllers are connected to hazardous line voltages. When servicing drives and electronic controllers, there might be exposed components with cases or protrusions at or above line potential. Extreme care should be taken to protect against shock.

Stand on an insulating pad and make it a habit to use only one hand when checking components. Always work with another person in case an emergency occurs. Disconnect power before checking controllers or performing maintenance. Be sure equipment is properly grounded. Wear safety glasses whenever working on electronic controllers or rotating electrical equipment.

## Revision History Table

No.	Revision Contents	The Date of Issue	Operation Manual No.
1	Initial Release of Manual NB616X	Feb. 2000	NB616X

## **WARNING**

Only qualified personnel shall carry out wiring work.  
Otherwise, there is a danger of electric shock and/or fire.

Implement wiring **after** checking that the power supply is off.  
Otherwise, there is a danger of electric shock and/or injury.

Be sure not to touch the inside and terminal of the option board while the inverter is energized.  
Otherwise, there is a danger of electric shock and/or injury.

Be sure not to remove the encoder line and feedback board during the operation.  
Otherwise, there is a danger of electric shock and/or fire.

After a lapse of more than 10 minutes after turning off the input power supply, perform the maintenance and inspection.  
Otherwise, there is a danger of electric shock

Make sure that only qualified persons will perform maintenance, inspection and part replacement.  
(Before starting the work, remove metallic objects from your person. Be sure to use tools protected with insulation)  
Otherwise, there is a danger of electric shock and/or injury.

Never modify the unit.  
Otherwise, there is a danger of electric shock and/or injury.

Be sure to implement wiring **after** installing the body.  
Otherwise, there is a danger of electric shock and/or injury.

 **CAUTION**

Do not allow substance such as cutting waste, sputtering of welding, waste of iron, wire and dust etc. to come into contact with the unit.

There is a fire risk.

Inverter main body and option board must be fixed tightly with the screw of the belonging.

There is a fear of contact defectiveness.

Tighten the screws of the encoder line on the option board so that there is no loose connection.

There is the fear of contact defectiveness.

Confirm that the power supply of the encoder is the same as the one in the option card (DC5V).

Otherwise, there is the danger of injury and/or fire.

Make sure that the direction of the motor is correct.

There is a danger of injury or machine damage.

Make sure there is no abnormal noise and vibration.

There is a danger of injury or machine damage

# CONTENTS

Contents	PAGE
Chapter 1 GENERAL DESCRIPTIONS	7
1.1 Inspection upon unpacking	7
1.2 Inquiry and Warranty of the Unit	7
1.2.1 Request upon inquiry	7
1.2.2 Warranty of the unit	7
Chapter 2 OUTLINE OF SJ-FB	8
Chapter 3 INSTALLATION	9
Chapter 4 WIRING AND CONNECTION	10
4.1 Terminal assignment of the Option Board	10
4.2 Function Explanation of the Terminal	11
4.3 Terminal connection diagram	12
Chapter 5 SETTING	14
5.1 Position of the setting switch	14
5.2 Feed-back board initial setting	14
5.3 Items regarding the feed back board of the inverter main body	15
5.4 Setting flowchart of the switch on the board	18
Chapter 6 OPERATION	19
Chapter 7 FUNCTIONS	21
7.1 Orientation function	21
7.1.1 Function outline	21
7.1.2 Data setting	23
7.2 Speed control (ASR)	24
7.3 Position control (APR) (Electronic gear function)	24
7.3.1 Function outline	24
7.3.2 Control mode setting	24
7.3.3 Data setting	25
7.3.4 Pulse train mode selection	28
7.4 Speed control (P/PI) switching function	29
7.5 Compensation of secondary resistor function	30
Chapter 8 PROTECTION FUNCTION	31
8.1 Action selection in case of option error	31
8.2 Cause and countermeasure of the option error	31
8.3 Warning display	31
Chapter 9 SPECIFICATION	32

## **1.1 Inspection upon packing**

Handle with care, not to give impact and vibration in case of unpacking. Please check the contents of the package for quantity and damage occurred during transportation.

(Packing contents)

1. SJ-FB (Feed back board) : 1
2. Instruction manual : 1
3. Board bind screws (M3×8mm) : 2

Please contact where you bought the unit as soon as possible when there is any problem.

## **1.2 Inquiry and Warranty of the Unit**

### **1.2.1 Request upon inquiry**

If you have any questions regarding damage of the unit, unknown parts or for general inquiries please contact your supplier or the local Hitachi Distributor with the following information.

- (1) Inverter Model
- (2) Production Number (MFG, NO)
- (3) Date of Purchase
- (4) Reason for Calling
  - Damaged part and its condition etc.
  - Unknown parts and their contents etc.

### **1.2.2 Warranty of the unit**

The warranty period of the unit is shown below.

#### **1 year after normal installation.**

However within the warranty period, the warranty will be void if the fault is due to;

- (1) Incorrect use as directed in this manual, or attempted repair by unauthorized personnel.
- (2) Any damage sustained, other than from transportation (which should be reported immediately).
- (3) Using the unit beyond the limits of the specification.
- (4) Act of God (Natural Disasters: Earthquakes, Lightning, etc)

The warranty is for the inverter only, any damage caused to third party equipment by malfunction of the inverter is not covered by the warranty.

Any examination or repair after the warranty period (one year) is not covered. And within the warranty period any repair and examination which results in information showing the fault was caused by any of the items mentioned above,. the repair and examination cost are not covered. If you have any questions regarding the warranty please contact either your supplier or the local Hitachi Distributor. Please refer to the back cover for a list of the local Hitachi Distributors.

This manual describes the application board SJ-FB for a SJ300 series inverter.

This SJ-FB board, assembled in a SJ300 inverter, detected the rotation speed of a motor with the encoder and feedback the motor speed to suppress speed fluctuations for highly accurate operation.

This SJ-FB board can also be used for controlling motor stop positions by entering 90 phase difference pulses, as well as for synchronized operation, orientation function, and external torque limit input function.

Figure 2-1 Function Block Diagram

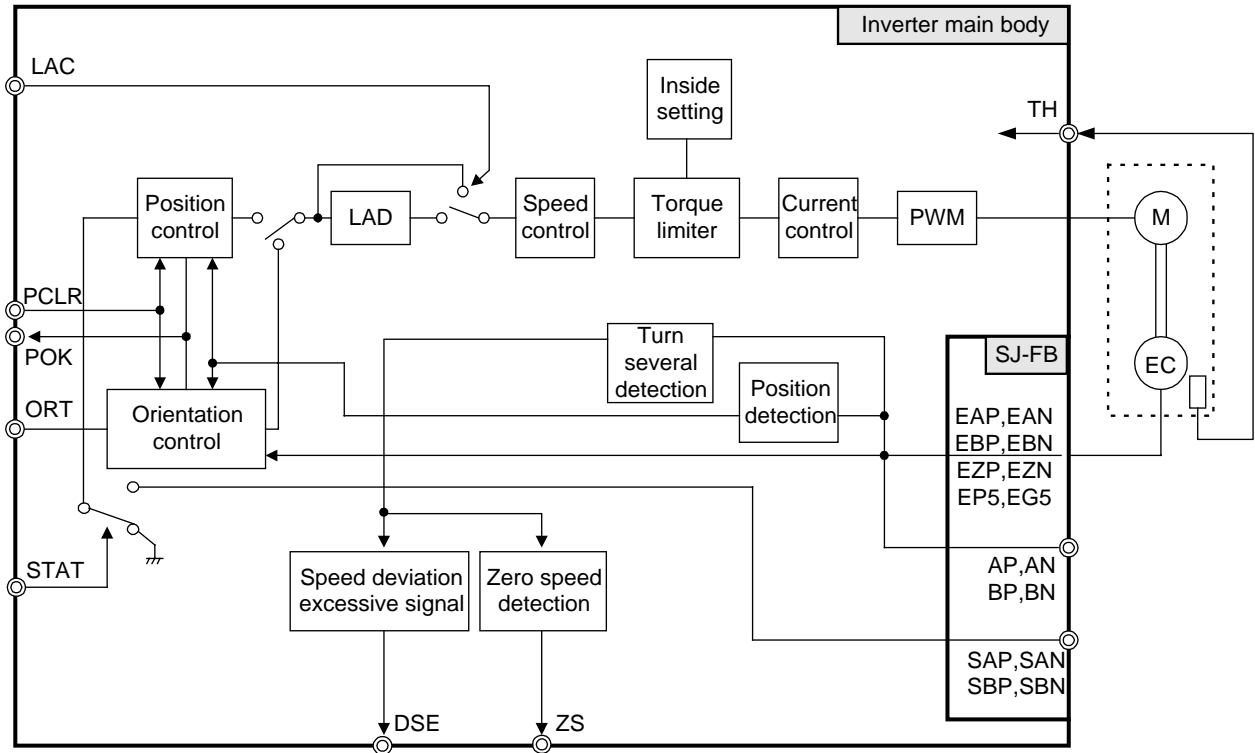

NOTE: Not vector control (ACR control)



## How to Mount the option Board

Please combine the hole at four corners of the option board to each guide post for option positioning, and screw hole for the fixation of this side of the body. Then connect the option board, in option port 1 or 2 of side of the body as shown below. Please fix 2 places of the board with the fixation screw of the belonging, to avoid loose connection.

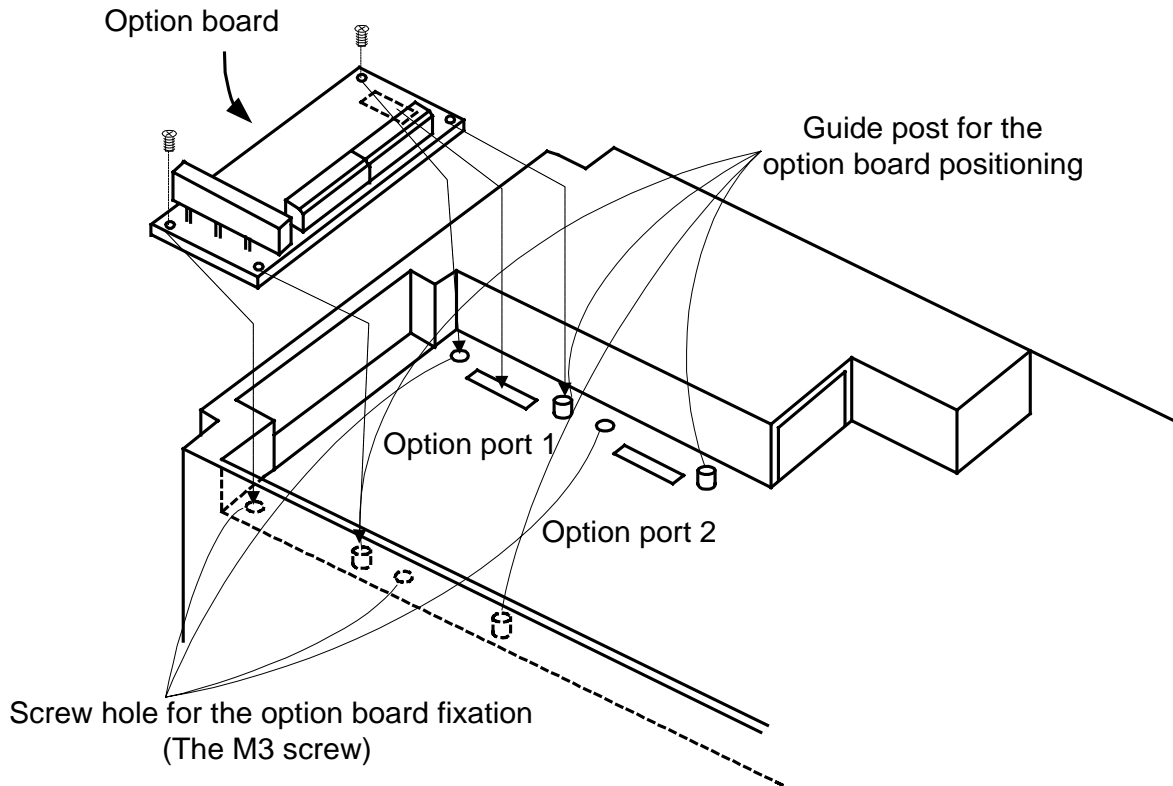
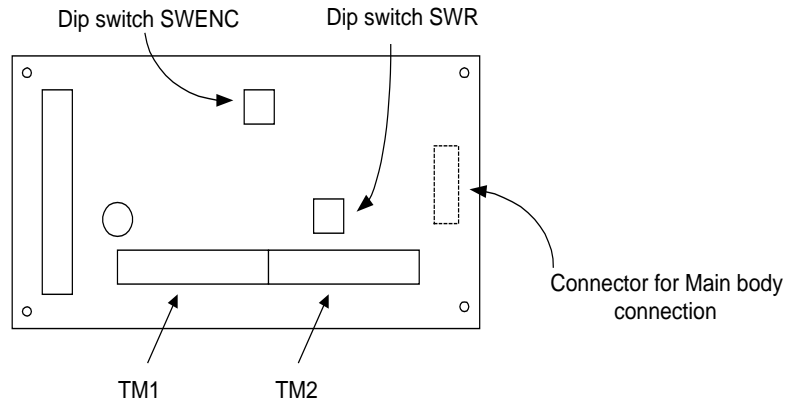

Figure 3-1 Option attachment figure

## 4.1 Terminal assignment of the Option Board

Outlook of SJ-FB



TM1 terminal assignment								TM2 terminal assignment							
EP5	EG5	EAP	EAN	EBP	EBN	EZP	EZN	SAP	SAN	SBP	SBN	AP	AN	BP	BN

Figure 4-1 Terminal assignment

## 4.2 Function Explanation of the Terminal

	Terminal	Code	Function	Common terminal	electric specification
Input terminals	Pulse line position command input	SAP SAN SBP SBN	Pulse train input (see page 16) •Mode 0 : 90 degree phase difference pulse •Mode 2 : Forward pulse/Reverse pulse •Mode 1 : Forward/Reverse signal, pulse train ON/OFF of the terminal resistance on the option board can be done by the dip switch. (Built in terminal resistance 150 ohm) Mode setting is done at the pulse mode selection (P013)		DC5V receiver input (based on RS-422 standard)
	Encoder signal input	EAP EAN EBP EBN EZP EZN	A, B, Z: rotary encoder signal input		Photo coupler input (Correspondence to the DC5V line driver type rotary encoder)
	Pulse train position command input permission signal (Note 1)	STAT	Position control with pulse train input is valid when STAT is Turned ON. (Note 3)	CM1	Photo coupler input (Refer to a main body intelligent input terminal.)
	Orientation signal: (Note 1)	ORT	Turning ON for orientation operation. (Note 3)		
	LAD cancel signal: (Note 1)	LAC	Turning ON for canceling LAD. (Note 3)		
	Position deviation clear signal: (Note 1)	PCLR	Turning ON for clearing position deviation counter. (Note 3)		
	Output terminals	Encoder signal output	AP AN BP BN	Outputting the Inputted encoder signal (ratio 1:1).	
Power supply for encoder		EP5 EG5	DC +5V power supply	EG5	150mA max
Positioning completion signal (Note 2)		POK	Used for position control or orientation. Output when the subject comes within the specified range (P017). (Note 3)	CM2	Open collector outputs (Refer to a main body intelligent input terminal)
Speed deviation excessive signal (Note 2)		DSE	Output when the real rotation speed deviates over from command speed (P027). (Note 3)		
Zero speed signal (note 2)		ZS	Output when the real rotation speed becomes zero speed detection level (C063). (Note 3)		

(Note 1): Valid when LAC is assigned to an intelligent input terminal of the main body (SJ300).

(Note 2): Valid when POK is assigned to an intelligent output terminal of the main body (SJ300).

(Note 3): Refer to the code setting method of SJ300

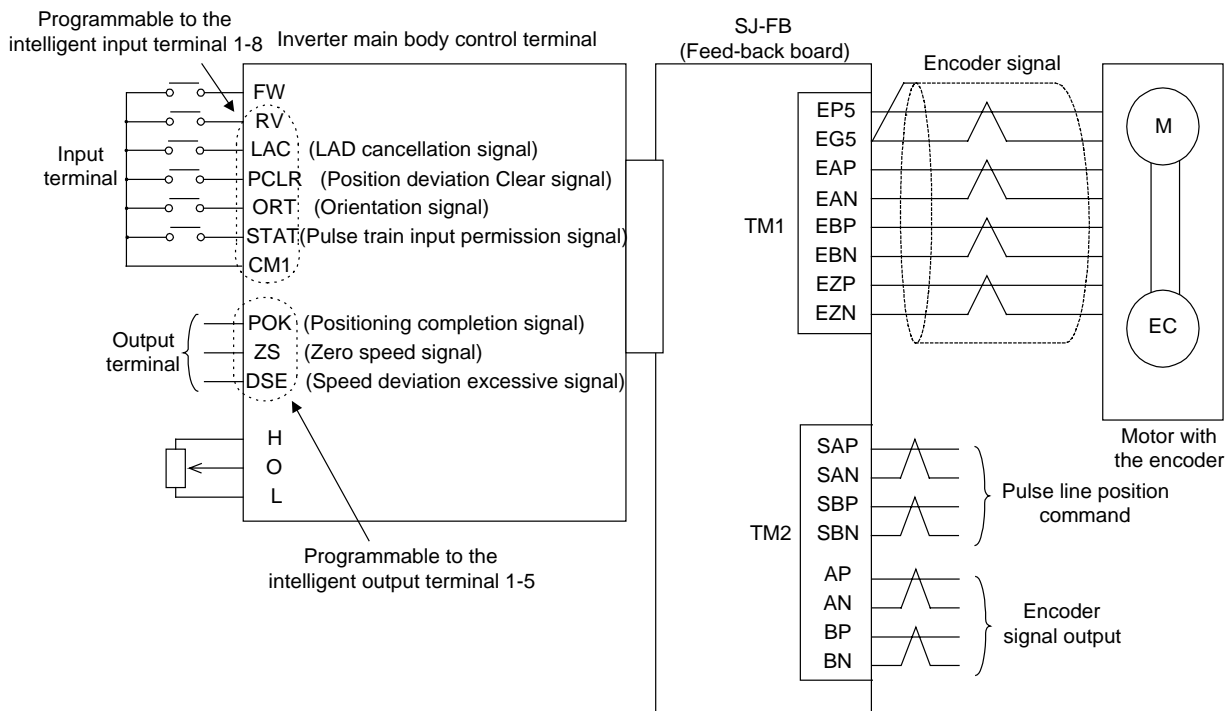

### 4.3 Terminal connection diagram

Figure 4-2 Terminal wiring

(Note 1) : Please refer to the instruction manual of the inverter main body about the wiring of the logic board.

(Note 2) : Use a twisted and shielded wire for the signal cables, and cut the shielded covering as shown in the diagram below. Make sure that the length of the signal cable is 20 meters or less. If the length exceeds 20 meters, please use a VX application control device RCD-E (remote control device) or CVD-E (insulation signal) to avoid malfunction caused by EMC noise or voltage drop. Also, electric wire for the encoder uses twist shield line of 0.75mm<sup>2</sup> or more (the example: Hitachi Cable, Ltd. KPEV-S), and make the distance less than 20m. In case of more than 20m, please use the relay amplifier of the 5V line driver specification output.

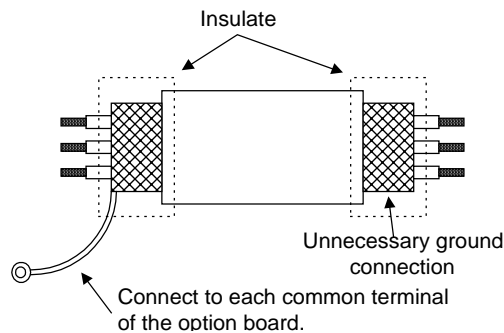

(Note 3) : Please separate the main circuit wiring from the relay control circuit wiring. If they

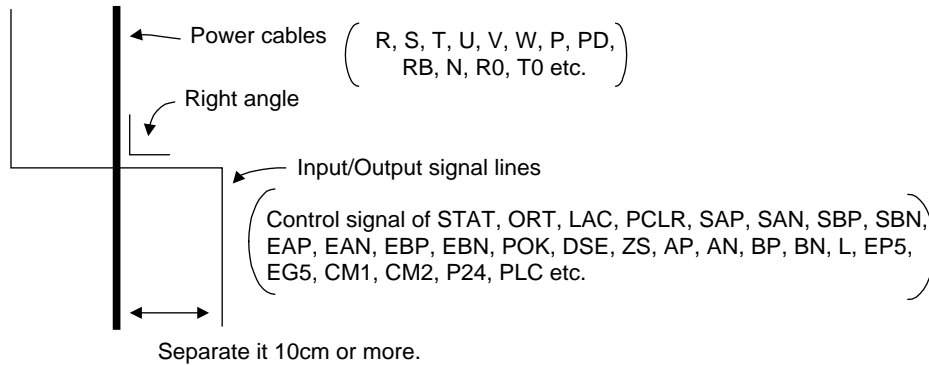

have to be crossed, be sure that they must be crossed at right angle.

(Note 4) : Don't make a short circuit between the EP5 and EG5 terminals. There is a danger of malfunctions.

(Note 5) : Isolate common signal for analog signal of the main body (L terminal of the logic card of SJ300) from common terminal of the SJ-FB.

(Note 6) : Please connect the encoder signal line properly so that the relationship among their phases become as shown below during rotation of the motor(Standard EG5).

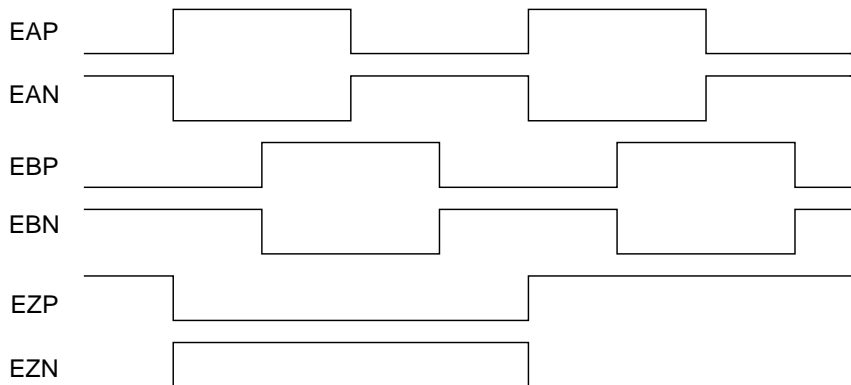

## 5.1 Position of the setting switch

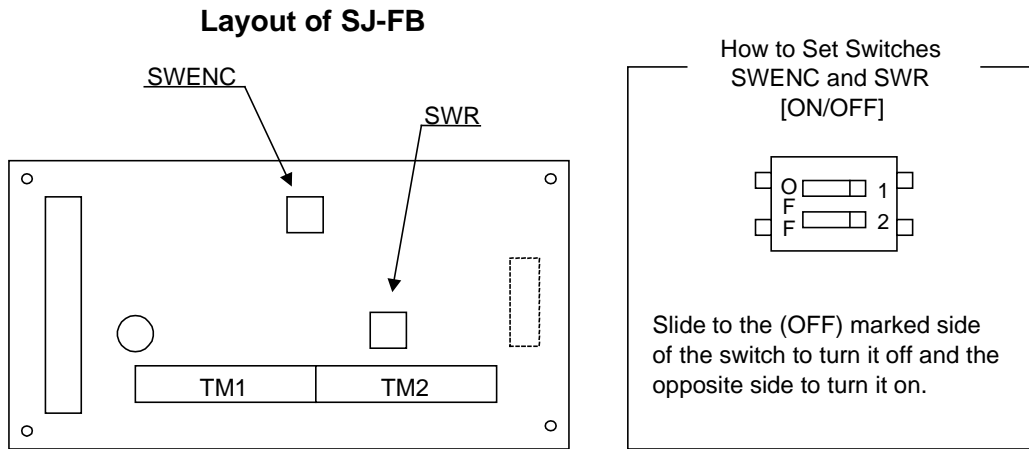

Figure 5-1 Switch arrangement figure

## 5.2 Feed-back board initial setting

Setting item	Switch No.	Contents	
SWENC	1	ON	Detection of disconnected A or B signal (EAP-EAN or EBP-EBN) is valid.
		OFF	Detection of disconnected A or B signal (EAP-EAN or EBP-EBN) is invalid.
	2	ON	Detection of disconnected Z signal (EZP-EZN) is valid.
		OFF	Detection of disconnected Z signal (EZP-EZN) is invalid.
SWR	1	ON	Terminal resistance is provided between SAP and SAN (150 ohm).
		OFF	No terminal resistance is provided between SAP and SAN.
	2	ON	Terminal resistance is provided between SBP and SBN (150 ohm).
		OFF	No terminal resistance is provided between SBP and SBN.

(Note) : All the switches are set to OFF as an initial setting.

### 5.3 Items regarding the feed back board of the inverter main body

Code	Function name	Setting range	Initial data	Setting on run	Change mode on run
A044	1 <sup>st</sup> control method	00(VC) / 01(VP1.7power) / 02(Free V/f Setting) / 03(SLV) / 04(0Hz area SLV) / 05(V2)	00	-	-
H001	Auto-tuning mode selection	00(NOR : Invalid) / 01(NRT : not rotate)/ 02(AUT : rotate)	00	-	-
H002	1 <sup>st</sup> motor constant selection	00(Hitachi standard motor constant)/ 01(Auto-tuning data)/ 02(Auto tuning data with online auto-tuning)	00	-	-
H003	1 <sup>st</sup> motor capacity selection	0.20 - 75.0(kW)	Setting on forwarding	-	-
H004	1 <sup>st</sup> motor pole selection	2/4/6/8 (Poles)	4	-	-
H005	1 <sup>st</sup> motor speed response setting	0.001 - 9.999 / 10.00 - 65.53	1.590		
H006	1 <sup>st</sup> stabilized factor	0. - 255.	100.		
H020	1 <sup>st</sup> motor R1 setting	0.000 - 9.999 / 10.00 - 65.53( $\Omega$ )	depends on the motor capacity	-	-
H021	1 <sup>st</sup> motor R2 setting	0.000 - 9.999 / 10.00 - 65.53( $\Omega$ )	depends on the motor capacity	-	-
H022	1 <sup>st</sup> motor L setting	0.00 - 99.99 / 100.0 - 655.35(mH)	depends on the motor capacity	-	-
H023	1 <sup>st</sup> motor I <sub>0</sub> setting	0.00 - 99.99 / 100.0 - 655.35(A)	depends on the motor capacity	-	-
H024	1 <sup>st</sup> motor J setting	0.000 - 9.999 / 10.00 - 99.99 / 100.0 - 9999.(kgm <sup>2</sup> )	depends on the motor capacity	-	-
H030	1 <sup>st</sup> motor R1 setting (Auto-tuning data)	0.000 - 9.999 / 10.00 - 65.53( $\Omega$ )	depends on the motor capacity	-	-
H031	1 <sup>st</sup> motor R2 setting (Auto-tuning data)	0.000 - 9.999 / 10.00 - 65.53( $\Omega$ )	depends on the motor capacity	-	-
H032	1 <sup>st</sup> motor L setting (Auto-tuning data)	0.00 - 99.99 / 100.0 - 655.35(mH)	depends on the motor capacity	-	-
H033	1 <sup>st</sup> motor I <sub>0</sub> setting (Auto-tuning data)	0.00 - 99.99 / 100.0 - 655.35(A)	depends on the motor capacity	-	-

Code	Function name	Setting range	Initial data	Setting on run	Change mode on run
H034	The 1 <sup>st</sup> motor J setting (Auto-tuning data)	0.000 - 9.999 / 10.00 - 99.99 / 100.0 - 9999.(kgm <sup>2</sup> )	depends on the motor capacity	-	-
H050	1 <sup>st</sup> PI control proportional gain setting	0.00 - 99.99 / 100.0 - 999.9 / 1000.(%)	100.0		
H051	1 <sup>st</sup> PI control integral gain setting	0.00 - 99.99 / 100.0 - 999.9 / 1000. (%)	100.0		
H052	1 <sup>st</sup> P control proportional gain setting	0.00 - 10.00	1.00		
H070	PI control proportional gain switching	0.00 - 99.99 / 100.0 - 999.9 / 1000.(%)	100.0		
H071	PI control integral gain setting	0.00 - 99.99 / 100.0 - 999.9 / 1000.(%)	100.0		
H072	P control proportional gain setting	0.00 - 10.00	1.00		
P001	Option 1 operation selection on error	00(TRP) / 01(RUN)	00	-	
P002	Option 2 operation selection on error	00(TRP) / 01(RUN)	00	-	
P011	Encoder pulse setting	128. - 9999. / 1000 - 6500 (10000 - 65000)(Pulse)	1024.	-	-
P012	Control mode selection	00(ASR Mode) / 01(APR Mode)	00	-	-
P013	Pulse line input mode selection	00(Mode 0) / 01(Mode 1) / 02(Mode 2)	00	-	-
P014	Stop position setting for orientation	0. - 4095.	0.	-	
P015	Frequency setting for orientation	0.00 - 99.99 / 100.0 - 120.0(Hz)	5.00	-	
P016	Direction setting for orientation	00(Forward) / 01(Reverse)	00	-	-
P017	Completion range setting for orientation	0. - 9999. / 1000(Pulse)	5	-	
P018	Completion delay time setting for orientation	0.00 - 9.99(s) (Note3)	0.00	-	
P019	Position selection for electronic gear	00(Position feed back side)/ 01(Position command side)	00	-	
P020	Numerator of ratio setting for electronic gear	0. - 9999.	1.	-	
P021	Denominator of ratio setting for electronic gear	0. - 9999.	1.	-	
P022	Feed forward gain setting for position control	0.00 - 99.99 / 100.0 - 655.3	0.00	-	
P023	Loop gain setting for position control	0.00 - 99.99 / 100.0	0.50	-	
P025	The 2 next resistance revision presence selection	00(Disable) / 01(Enable)	00	-	
P026	Over speed abnormal detection level	0.00 - 99.99 / 100.0 - 150.0(%) (Note 2) (Note 3)	135.0	-	
P027	Speed error over detection level	0.00 - 99.99 / 100.0 - 120.0(Hz) (Note 2)	7.50	-	



(Note 1) : Please refer to the instruction manual of the inverter main body as to the setting procedure.

(Note 2): When the over speed abnormal detection level (P026), the speed error over detection level (P027) are set 0, the Abnormal detection data processing will be invalid.

(Note 3): Regarding the SJ-FB setting, there are some warning about what type of main body combines with the SJ-FB which is written following list.

No.	Item	Main body of SJ300 Production No (MFG No) (Note 4)	
		9 8 XXXXXXXXXXXXX 9 9 XXXXXXXXXXXXX 9 0 XXXXXXXXXXXXX 9 J XXXXXXXXXXXXX 9 K XXXXXXXXXXXXX 0 1 XXXXXXXXXXXXX	others
1	Completion delay time setting for orientation (P018)	Range of setting: 0.00 - 9.99 (X10(sec)) (Example) In order to operate the completion delay time setting for orientation for 1(sec). Set P018 setting which is written below. P018=1(sec)/10(sec)=0.10	Range of setting: 0.00 - 9.99 (X1(sec)) ( Example) In order to operate the completion delay time setting for orientation for 1(sec). Set P018 setting which is written below. P018=1(sec) / 1(sec)=1.00
2	Over speed abnormal detection level	Range of setting: 0.0 - 150.0 (X100) (Example) In order to operate the over speed detection level at 66Hz while maximum frequency is 60Hz. Set P026 setting which is written below. P026=66Hz / 60Hz=1.1	Range of setting: 0.0 - 150.0 (X1%) (Example) In order to operate the over speed detection level at 66Hz, while maximum frequency is 60Hz. Set P026 setting which is written below. P026=66Hz / 60HzX100=110.0

(Note 4) Main body of SJ300 Production number (MFG No) is written main body of SJ300 specifications label. Refer to figure 5-2(1), figure 5-2(2) please.

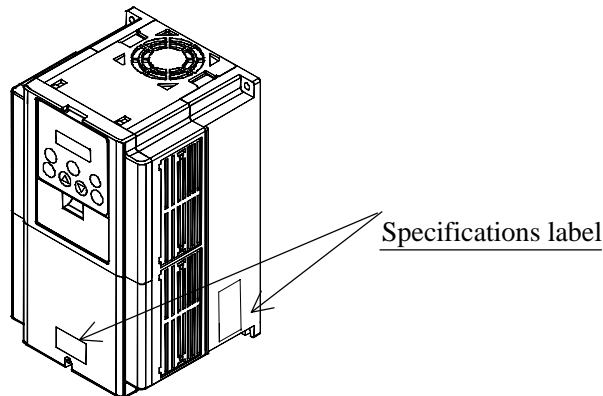

Figure 5-2(1) position of specification

		<b>HITACHI</b>	
Inverter model	→	Model:	SJ300-055HF
Maximum applicable motor	→	kW/(HP):	5.5/(7.5)
Input ratings	→	Input/Entrée:	50Hz, 60Hz    400-480 V 1 Ph    A
			50Hz, 60Hz    400-480 V 3 Ph    13 A
Output ratings	→	Output/Sortie:	0.1-400Hz    V 3 Ph    12 A
Production number	→	MFG No.	94AT1234590001    Date: 9904
			Hitachi, Ltd, MADE IN JAPAN    NE16989-27

Figure 5-2 (2) Contents of specification label

**5.4 Setting flowchart of the switch on the board**

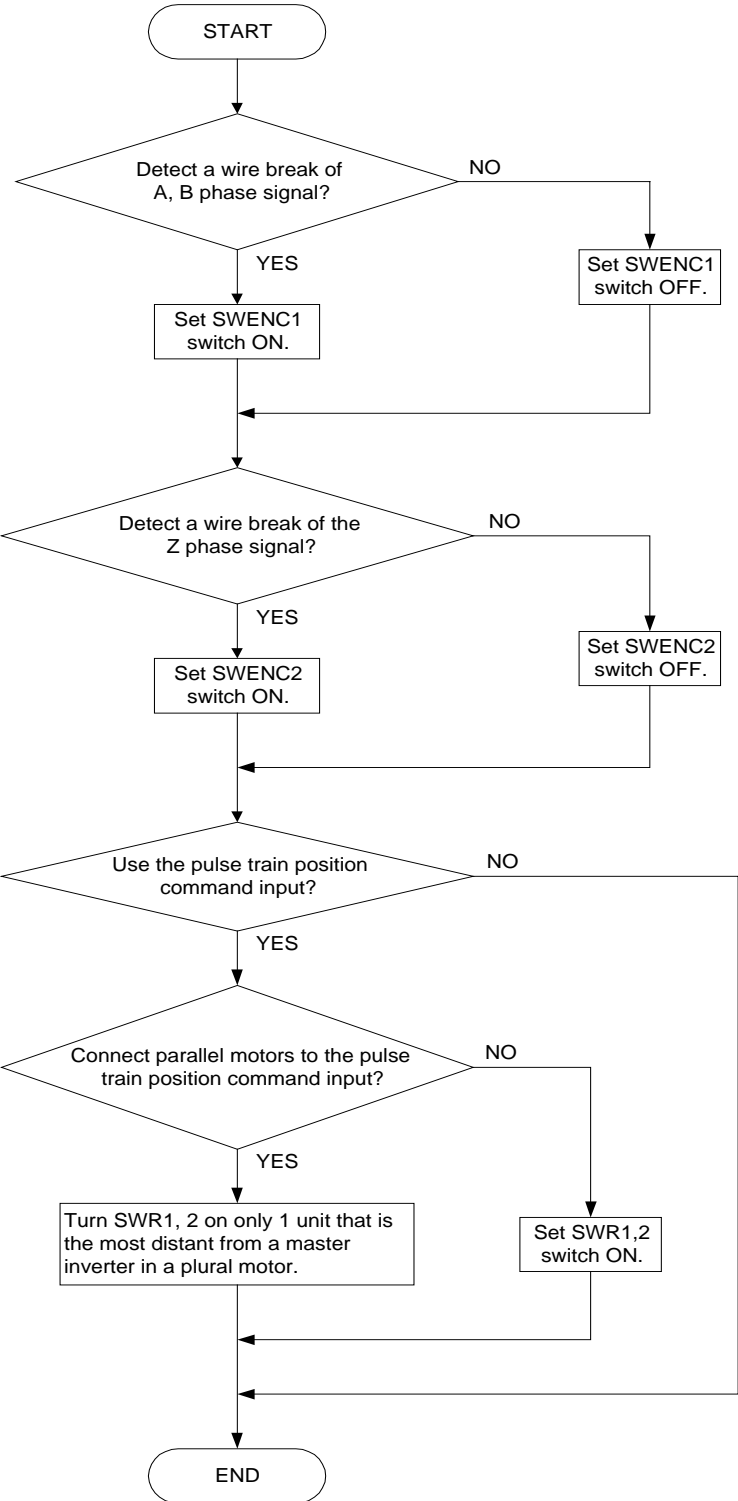

Figure 5-3 Switch setting flowchart

Refer to [Chapter 3 OPERATION] in the instruction manual for the SJ300 inverter before operating with this board. When the operation command is given from the terminal side of the inverter main body, operate with the following procedure.

<Procedure>

1. Turn ON the POWER switch of the inverter.
2. Set the control method (A044) in [05].
3. Set the necessary items according to the instruction manual "Chapter 4 FUNCTION EXPLANATION" of the inverter main body.
4. For speed control, operation is started when operation command of the inverter main body is turned on.
5. For position control, turn on the STAT terminal of SJ-FB and operation command of the inverter main body first of all. Next input the pulse train position command to SAP-SAN and SBP-SBN. Then the motor turns only the pulse that you input.

Confirm the following while trial operation.

The motor accelerates normally.

The motor rotates in the correct direction.

Neither abnormal vibration nor noise is recognized in the motor.

If the motor doesn't accelerate normally or the inverter trips with overload, check the encoder for phase order.

Phase order : The normal phase order is that the waveform of phase A advances by 90° than that of phase B when the motor rotates forward.

(Note 1) : The monitor signal may not be output from FM terminal of inverter main body under vector control with sensor (A044=05). Please confirm the monitor output in this case.

(Note 2) : Please do not do the free run action by "RS terminal" of inverter main body. When you do this action, over current trip, or power element destruction may occur. Please use "FRS" the terminal when performing free run action.

(Note 3) : If the torque limit setting (b041-b044) is enlarged, over current trip would occur at the time of the motor added burden. In this case, please adjust the torque limit setting value.

(Note 4) : The motor constant data of the SJ300 series is the data at the time of base frequency 50Hz in the J1 motor made in Hitachi. . Please put in the value that did it to motor constant I0 (H023) 0.7 times, in the case that you use it with base frequency 60Hz in the J1 motor.

(Note 5) : Please do the auto tuning, in the case that you do not understand the motor constant.

(Note 6) : If satisfactory performance can not be obtained, please adjust the motor constant for the phenomena according to following table.

Status of running	Phenomena	Contents of adjustment	Adjusting parameter
At starting	The shock is occurred at starting	Set "Motor constant J" bigger and bigger slowly until 1.2 times for preset constant.	H024/H034
At deceleration	Unstable of motor rotation	Set speed response smaller.	H005
		Set "Motor constant J" smaller for preset Constant.	H024/H034
During torque limit	Insufficient torque during torque limit at low speed	Set overload restriction level lower than torque limit level	b021 b041-b044
At low frequency operation	Irregular of rotation	Set "Motor constant J" bigger for preset constant.	H024/H034

## 7.1 Orientation function

This board is provided with the orientation function used to position the motor at a certain point during operation. This function can be used for replacing a component of the main axis of the subject machine tool for example.

### 7.1.1 Function outline

The orientation function maintains position which has decided with the position control after speed control operation. The action is shown in Figure 7-1.

Relation

A044: 1<sup>st</sup> Control Method  
 P014: Orientation Stop Position  
 P015: Orientation Speed setting  
 P016: Orientation Direction setting  
 P017: Completion range setting  
 P018: Completion delay time  
 P023: Position Loop gain  
 C001-C008: Intelligent input terminal  
 C021-C025: Intelligent output terminal

1. In the speed control operation period, inverter drives at constant speed with the orientation speed setting (P015). (Orientation mode becomes valid when turning RUN command ON under ORT is being ON.)
2. After arriving to the orientation speed setting(P015), the first coming the Z pulse is detected after that the control mode moves to the position control.
3. Inverter controls the motor to stop at a certain stop position which is set to (P014) during position control operation period.

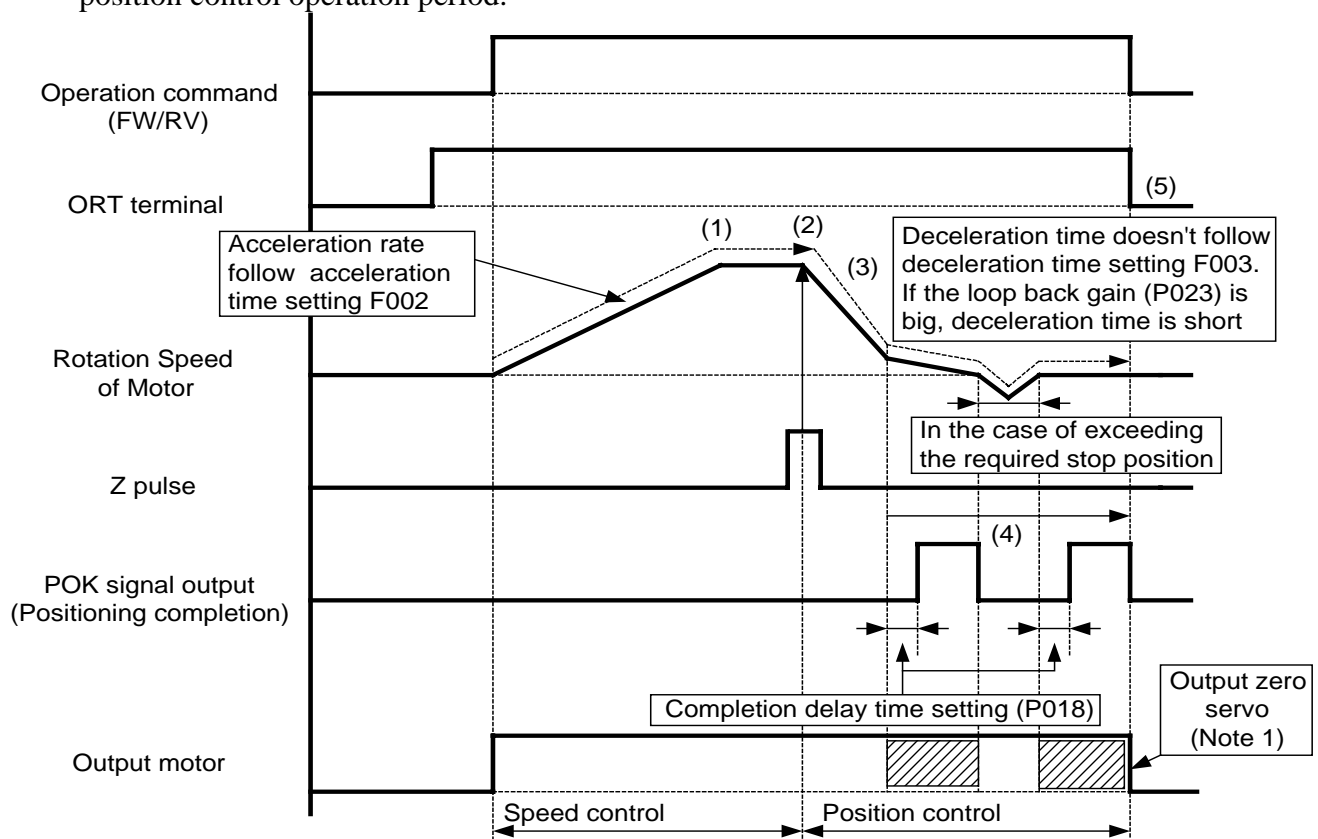

(Note 1) ⚠ Rotation speed of the motor is zero but inverter is outputting to the motor. Don't touch the motor power line. Otherwise, there is a danger of electric shock and/or injury.

(Note 2) In case of reoperating when the operation command is set terminal. Set the command operation(FW,REV)again.

Figure 7 - 1(1) Orientation and timing  
 (Action timing of when the ORT input signal is OFF during the orientation.)

4. Inverter maintains the position after the completion, and outputs the 'position control completion (POK) signal' after the set value of 'delay time setting (P018). (Inverter drives the motor reverse and return to the required stop position in the case it exceeds the required stop position.)
5. When the ORT terminal is turned off, the inverter stops operation and the orientation mode is cleared.

(Note3) In case of using Z pulse, use 5V line driver type output for EZN-EZN input.

(Note 4): Action timing of when only the operation command is OFF during the orientation.

If only the operation command is OFF, the motor will stop (1). After that if the ORT terminal is OFF(2), POK signal output will be OFF (3).

(While ORT terminal is ON. Due to the orientation mode is running , even though only the operation command is OFF , the POK signal output (4) keep ON within the completion range.

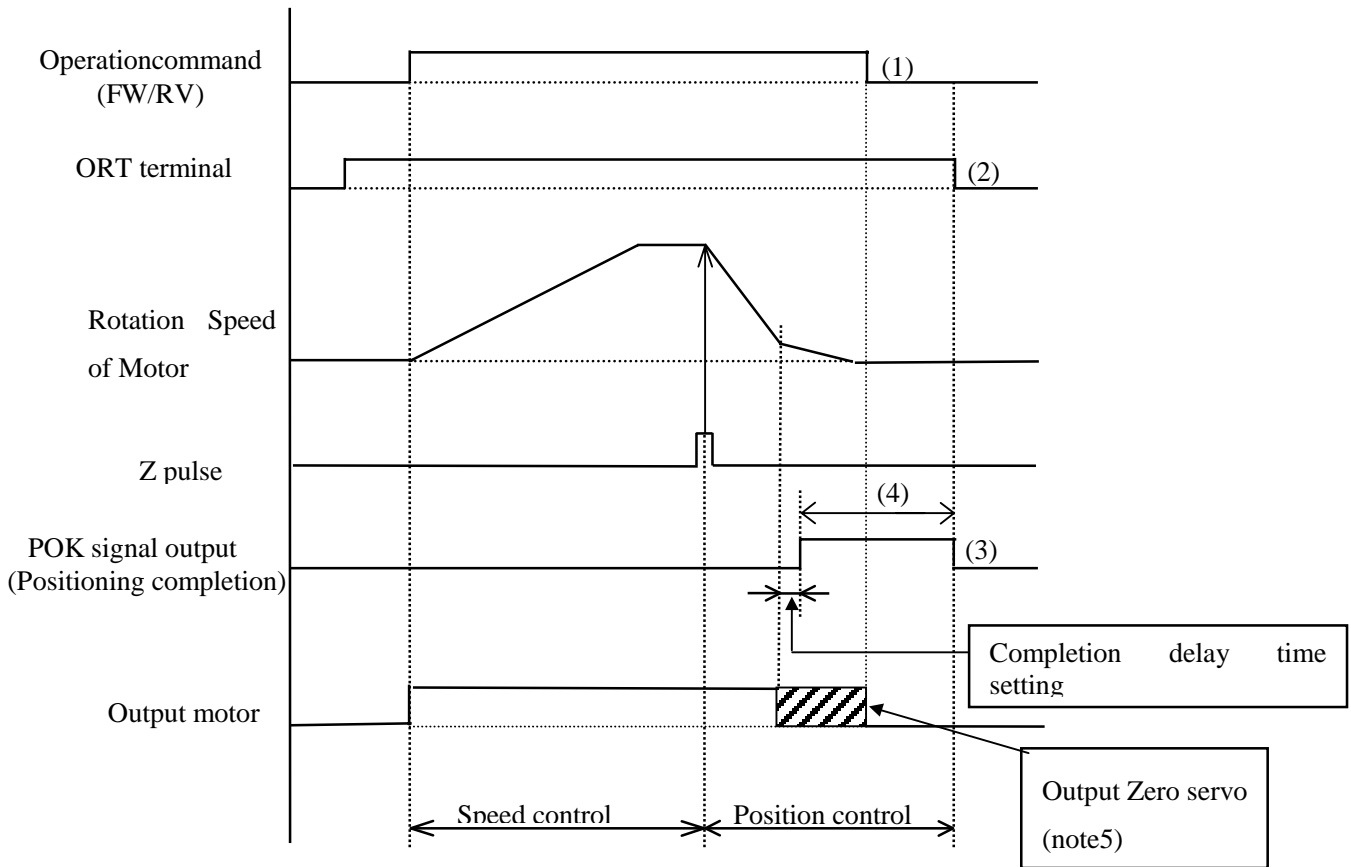

Figure 7 - 1(2) Orientation and timing

(Action timing of when only the operation command is OFF during the orientation.)

(Note 5) ⚠ Rotation speed of motor is zero but inverter is outputting to the motor.

Don't touch the motor power line. Otherwise there is a danger of electric shock /Injury.

### 7.1.2 Data setting

Data setting related to speed control

Setting item	Function code	Setting Range, Setting Contents
Orientation speed setting (Note 1)	P015	0.00~99.99 / 100.0~120.0 (Hz)
Orientation direction setting (Note 2)	P016	0:Forward / 1:Reverse

(Note 1) : In order to stop the motor for setting position. (Motor takes 2 rotation to stop setting position) Don't set high frequency to the orientation speed setting. Otherwise it will be over-voltage protection trip.

(Note 2) : Turn direction of the motor while orientation is done based on the setting of P016.

Data setting related to position control

Setting item	Function code	Setting range, setting contents
Orientation stop position(Note 3)	P014	0. ~4095.
Completion range setting	P017	0~9999. / 1000 (10,000) (pulses) (Setting four times fairly of the encoder pulses)
Completion delay time (Note 4)	P018	0.00~9.99
Position loop gain(Note 5)	P023	0.00~99.99 / 100.0 (rad/s)

(Note 3) : The orientation stop position is to be set as 4096 of division (0~4095) per 1 turn toward forward from the original point. (It is 4096 division irrespective of the pulse number of the encoder.) The original point is where the pulse has input to EZP-EZN. Stoppage goal position is like shown in Figure 7-2 irrespective of the turn direction.

(Note 4) : It depends on what type of main body combines with the SJ-FB, the setting value conversion is different. Please refer to the (Note 3) of the "5.3 Items regarding the feed back board of the inverter main body".

(Note 5) : To improve the positioning accuracy. → Increase position loop gain (G).  
When the motor is unstable. → Decrease position loop gain.

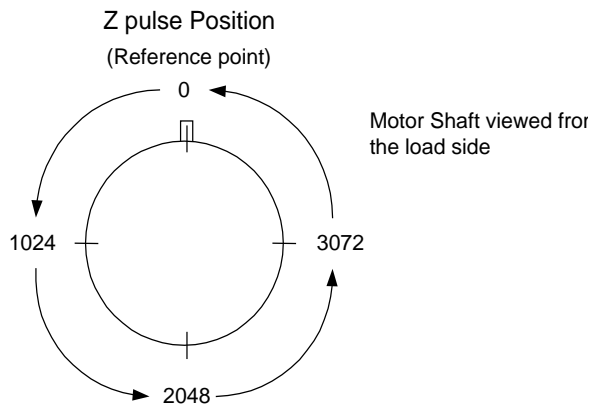

Figure 7-2 Concept of Orientation setting Position

Data setting of the input-output terminal

	Input-output terminal	Terminal assignment	Contents
Input	ORT terminal (ORT)	Set up 45 to one of them of C001~C008	ON : Orientation mode
Output	Positioning completion signal (POK)	Set up 23 to one of them of C021~C025	Output when it comes to the positioning completion range.

**7.2 Speed control (ASR)**

When the control mode selection (P012) is set to 00, operation mode becomes a speed control operation mode (ASR mode).

Please drive after setting up the frequency, operation command and each motor constant .

Relation

A044: 1<sup>st</sup> Control method  
 P012: Control mode selection  
 A001: Frequency command selection  
 A002: Operation command selection  
 F001: Frequency setting  
 F002: Acceleration time  
 F003: Deceleration time  
 F004: Operation direction selection  
 H002/H202-H052/H252: Motor constant relation data

**7.3 Position control (APR)  
(Electronic gear function)**

When the control mode selection (P012) is set to 01, operation mode becomes a speed control operation mode (APR mode).

**7.3.1 Function outline**

This function generates the frequency based on the position command pulse which comes from the pulse train input from the terminal and position feed back pulse which is detected by the motor encoder, and performs the position control operation. It can be used as synchronous operation of main and sub motor. Also the turn ratio of main and sub motor can be changed by setting up the electronic gear ratio (N/D). (Electronic gear function)

Relation

A044: 1<sup>st</sup> Control method  
 P012: Control mode selection  
 A002: Operation command selection  
 P017: Completion range setting  
 P018: Completion delay time  
 P019: Electronic gear position selection  
 P020: Electronic gear ratio numerator  
 P021: Electronic gear ratio denominator  
 P022: Feed forward gain  
 P023: Position loop gain  
 C001-C008: Intelligent input terminal  
 C021-C025: Intelligent output terminal  
 H002/H202-H052/H252: Motor constant relation data

**7.3.2 Control mode setting**

Inverter at the main motor (master inverter) can be set both as a speed control and position control. Please set up the inverter at the sub motor side (slave inverter) to a position control mode.



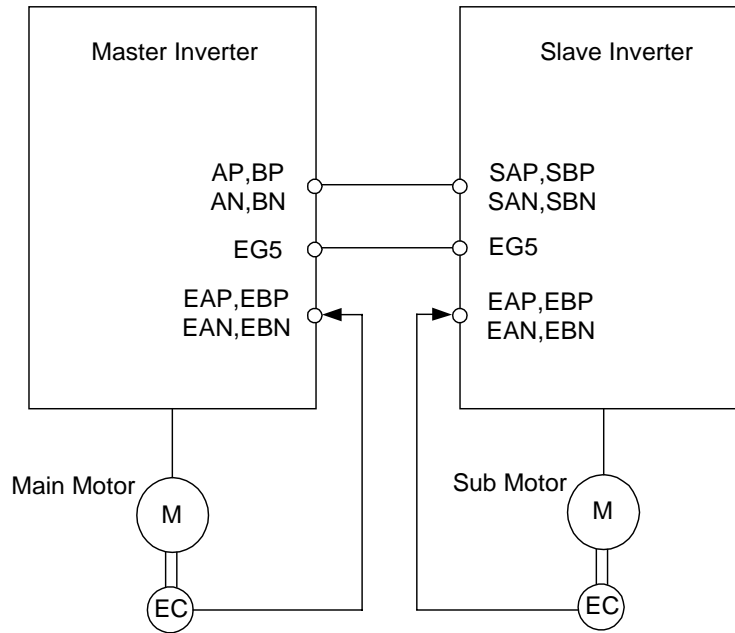

**Figure 7-3 Wiring for Synchronized Operation**

(Note) : Please connect EG5 of the main and sub inverter together to avoid malfunction caused by EMC noise.

### **7.3.3 Data setting**

Data setting related to position control

Setting item	Function code	Setting range, setting contents
Feed-forward gain (Note 1)	P022	0.00~99.99 / 100.0~655.3
Position loop gain (Note 2)	P023	0.00~9.99 / 100.0 (rad/s)
Electronic gear position selection (Note 3)	P019	00: to the feed back side (FB) 01: to the position command side (REF)
Numerator of the electronic gear ratio (Note 3)	P020	1~9999
Denominator of the electronic gear ratio (Note 3)	P021	1~9999
Completion range setting	P017	0~9999. / 1000 (10,000) (pulse)
Completion delay time	P018	0.00~9.99 (s)

(Note 1) : We promote the adjustment from P022=2.00 at the time of the feed forward gain adjustment .To make the position deviation of the main and sub motor small, then increase feed forward gain. When the motor is unstable, then decrease feed forward gain

(Note 2) :We promote the adjustment from P023=2.00 at the time of the position loop gain adjustment. To get good accuracy of the position control then increase position loop gain, then to get much power to maintain the positioning then increase position loop gain. Motor is unstable due to too big position loop gain, then decrease position loop gain.

(Note 3) : N/D must be given as the ranges of  $1/50 \leq (N/D) \leq 20$ .

(N: Electronic gear ratio numerator, D: Electronic gear ratio denominator)

(Note 4) : It depends on what type of main body combines with the SJ-FB, the setting value conversion is different. Please refer to the (Note 3) of the “5.3 Items regarding the feed back board of the inverter main body“.

#### Data setting of input-output terminals

	Input-output terminal	With terminal assignment	Contents
Input	The pulse train position command input permission signal. (STAT)	Set '48' to one of C001~C008	Pulse train position command input is valid while ON.
Output	Positioning completion signal.(POK)	Set '23' to one of C021~C025	Output when it entered into the positioning completion range

Set '48' (the pulse train position command input permission signal (STAT)) to one of C001~C008. Pulse train position command input is valid only in the case that the STAT terminal is turned ON. In the case that the STAT terminal is OFF or unestablished, pulse train position command input is invalid.

Below the example of the proportion of the slave side turn number to the master side turn number by the setting of P019 P021 is shown. (Yet, the encoder pulse number of the master side and slave side are same and be in the case of 1024 pulses. )

Position selection for electronic gear (P019)	01 (REF)	01 (REF)	00 (FB)	00 (FB)
Numerator of ration setting for electronic gear (P020)	1024	2048	1024	2048
Denominator of ratio setting for electronic gear (P021)	2048	1024	2048	1024
Slave side turn number to the master side turn number	1/2	2	2	1/2

[Setting example]

Main Motor : Encoder pulse 1024 pulses

Sub Motor : Encoder pulse 3000 pulses

(Main motor rotation speed) : (sub motor rotation speed) = 2 : 1

Set the following for slave inverter in this case.

Electronic gear setting position (P019) : RET (command pulse side)

Electronic gear numerator (P020) : 3000

Electronic gear ratio denominator (P021):  $1024 \times 2 = 2048$

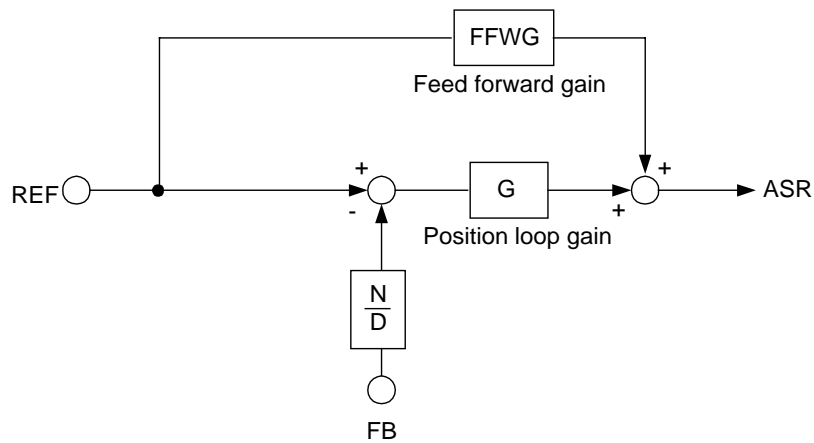

Electron gear establishment position selection = FB

Figure 7-4 Control block diagram of the electron gear function (1)

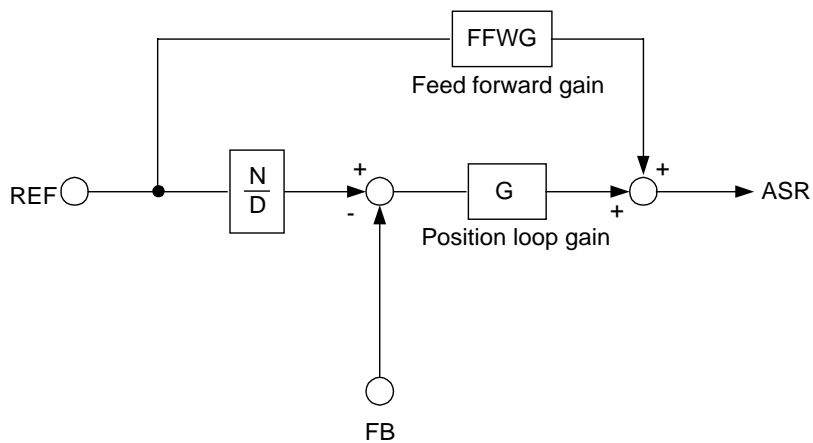

Electron gear establishment position selection = REF

Figure 7-5 Control block diagram of the electron gear function (2)

### 7.3.4 Pulse train mode selection

The following 3 ways of pulse line input can be selected by the setting of P013.

#### 1) 90° phase difference pulse train (Mode 0)

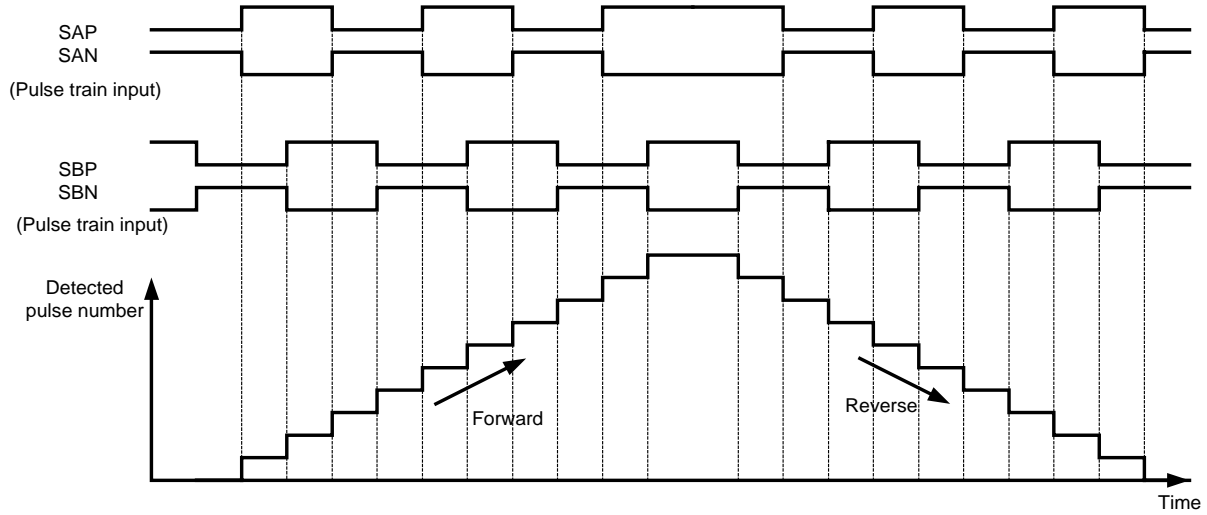

#### 2) Forward/Reverse command + pulse train (mode 1)

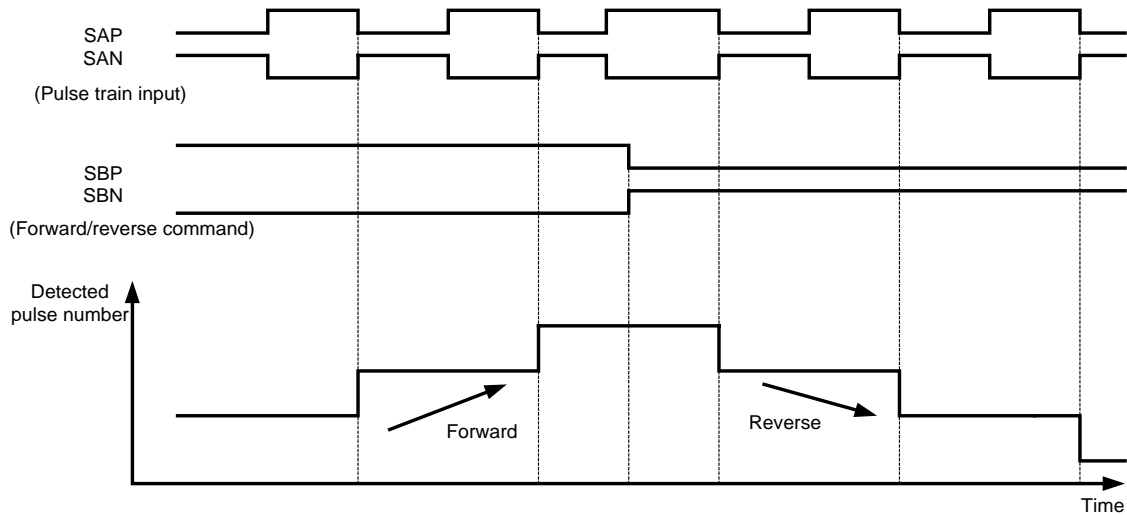

#### 3) Forward pulse train + Reversion pulse train (mode 2)

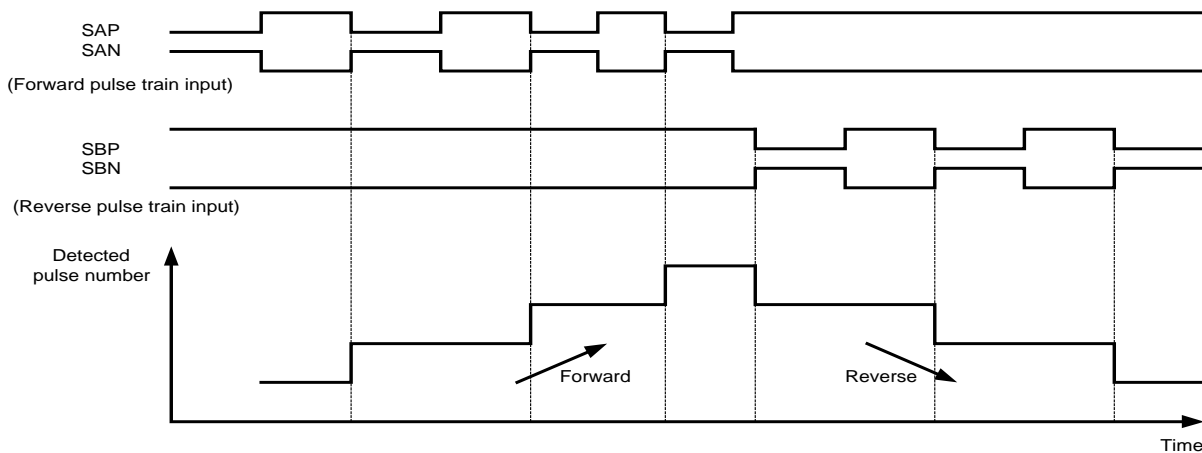

### 7.4 Speed control (P/PI) switching function

Speed control mode is normally controlled by proportional-integration compensation (Pi), which keeps the deviation between the actual speed and speed command becomes 0. Further, you can also achieve a propotional control function, which can be used as drooping operation (i.e. one load with several inverters) with this option card.

Relation

A044: 1<sup>st</sup> Control Method  
 P052: 1<sup>st</sup> Proportional gain  
 C001-C008: Intelligent input terminal

Set P/PI switching function to one of the intelligent input terminal 1~8 by the operator to achieve this function. (Input '43' in one of C001~C008.) When this is turned on, control mode becomes proportion control (P).

Please set proportional gain(Kpp ; a value used to decide the speed change rate) to H052 by a digital operator. The relationship between the Kpp value and the speed change rate is shown below.

$$(\text{Speed Change Rate}) = \frac{10}{(\text{Kpp Set Value})} (\%)$$

#### Relationship between Kpp Value and Speed Change Rate

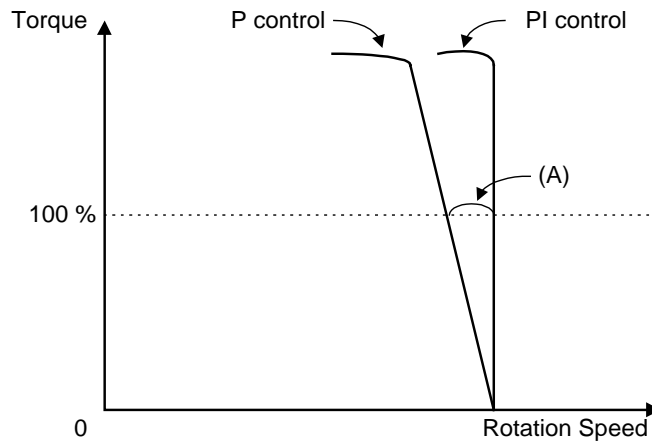

Figure 7-6 Torque characteristic (P/PI)

$$(\text{Speed Change Rate}) = \frac{\text{Speed Error at Rated Torque (A)}}{\text{Synchronous speed base frequency}}$$

#### Relationship between Speed Change Rate and Rated Rotation Speed

## 7.5 Compensation of secondary resistor function (Temperature revision)

Please use this function, if you want to do the temperature revision to restrain the speed fluctuation by the temperature change of the motor. (Please use the thermistor of the characteristic like type B that shows it below. (This thermistor is the characteristic of PE-41E made of a Shibaura electronics co.,Ltd.))

1. Please wire the thermistor that is built to the motor to the inverter.  
(Wiring between TH and CM1 of the terminal unit board of the main body)
2. Please set up it as follows.

P025.....01(valid)    b098..... 02(NTC)

b099.....(This code is thermistor error level setting. Set the resistance value of temperature for trip according to thermistor methods.)

C085.....(Use this as gain adjustment.)

### Relation

P025: Compensation of secondary resistor selection  
b098: Thermistor selection  
b099: Thermistor error level  
C085: Thermistor adjustment

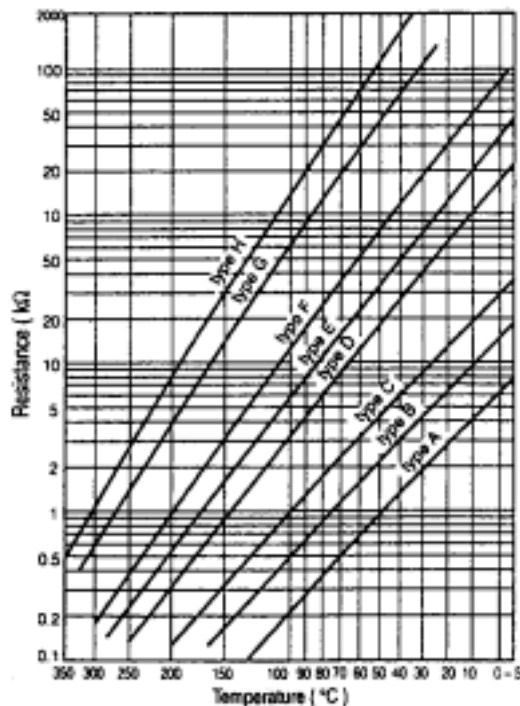

Figure 7-7 Resistor vs. Temperature Curves

(Note):Please wire it once again after the thermistor error occurrence level is changed, after you remove the wiring of the thermistor once, if the thermistor error occurred.

## **8.1 Action selection in case of option error**

To ignore or make inverter trip can be selected in case of option error.

Item	Function code	Data	Contents
Action selection in case of option error	P001 / P002	00	TRP: Inverter trips and outputs alarm signal.
		01	RUN: Inverter ignores the option error and continues the operation.

(Note) : Inverter trips anyway in case of encoder line break error (E60, E70), SJ-FB abnormal connection (E69,E79) occurs, although action selection is set to 01 (RUN). Please refer to "Chapter 5.2 FEED-BACK BOARD INITIAL SETTINGS".

## **8.2 Cause and countermeasure of the option error**

When any of the following alarms occurs, the inverter displays the alarm cause and stops.

Display	Item	Contents	Processing
E60 (E70) (Note 1)	Encoder line break	Detect the line break or disconnection of the encoder line.	Check the encoder signal line and connection.
		Detect when there is an encoder failure. Detect when the specification of the encoder is not line driver output type.	Replace it to a suitable one.
		Detect when there is no Z pulse.	Turn SWENC-2 OFF on the option board.
E61 (E71) (Note 1)	Over speed	Detect when the motor rotation speed exceeds (maximum frequency (note 2))×(over speed error detection level (P026). (Note 3),(Note 4)	Adjust the Kp and J constants related to the speed control system to reduce overshoot.
E62 (E72) (Note 1)	Positioning error	Detect when the deviation of the current position and command value becomes more than 1,000,000 pulses during position controlling.	Increase the position loop gain. Decrease the numbers of the pulse train input per second.
E69 (E79) (Note 1)	connection error	Detect abnormal connection between the inverter main body and SJ-FB.	Check the connection between the inverter main body and SJ-FB.

(Note 1): ( ) shows when the option card is connected to option slot 2.

(Note 2): Frequency upper limit value (A061/A261) is reflected when it is set.

(Note 3): It depends on what type of main body combines with the SJ-FB, the setting value conversion is different.

Please refer to the (Note 3) of the “5.3 Items regarding the feed back board of the inverter main body“.

(Note 4): When the over speed error occurred . There is a possibility the over speed error occur again. Even though the trip is cleared during the motor free run. In this case stop the motor, then clear the trip please.

## **8.3 Warning display (Feed back option relation)**

(Refer to the operation manual of the main body about the warning other than the following,)

The  $\square$ 009 is displayed in the case that it became orientation speed setting (P015) > the highest frequency setting (A004). Please confirm the case, orientation speed setting (P015) and highest frequency setting (A004).

**Product specification**

Item		Specification
Speed control	Encoder feed-back:	<ul style="list-style-type: none"> <li>• Standard encoder pulse number 1024 pulse/r</li> <li>• Max. input pulse 100k pulse/s</li> </ul>
	Speed control system:	<ul style="list-style-type: none"> <li>• Proportional-Integral (PI) / Proportional (P) control</li> </ul>
Position control	Position command:	<ul style="list-style-type: none"> <li>• Three kinds of pulse train input selectable by main body setting. Mode 0 : 90° phase difference pulse Mode 1 : Forward/Reverse signal pulse Mode 2 : Forward pulse/Reverse pulse</li> <li>• Max. input pulse 100k pulse/s</li> </ul>
	Electronic gear:	<ul style="list-style-type: none"> <li>• Pulse ratio A/B (A, B: 1~9999 selectable)</li> <li>• Setting range <math>1/50 \leq A/B \leq 20</math></li> </ul>
Orientation	Stop position:	<ul style="list-style-type: none"> <li>• 4096 division against 1 rotation of the motor shaft (Note 1)</li> </ul>
	Speed:	<ul style="list-style-type: none"> <li>• Orientation speed and turn direction selectable</li> </ul>
Protection function		<ul style="list-style-type: none"> <li>• Encoder cable line break protection</li> <li>• Over speed protection (over speed error detection level (P026)) (Note 2)</li> <li>• Positioning error</li> <li>• Connection abnormal of SJ-FB</li> </ul>

(Note 1): The main body setting or external input is selectable.

SJ-DG (digital input option board) is required in case of external input.

(Note 2): It depends on what type of main body combines with the SJ-FB, the setting value conversion is different.

Please refer to the (Note 3) of the “5.3 Items regarding the feed back board of the inverter main body”.