

GETTING STARTED



In This Chapter ...

Manual Overview	1-2
Overview of This Publication	1-2
Who Should Read This Manual	1-2
Supplemental Publications	1-2
Technical Support	1-2
Special Symbols	1-2
<i>SureServo™</i> AC Servo Systems Introduction	1-3
<i>SureServo™</i> Basic Overview	1-3
Unpacking Your New <i>SureServo™</i>	1-4
Nameplate Information	1-5
Model Explanation	1-5
Identification and Labeling: <i>SureServo™</i> AC Servo Drive	1-6
Drive and Motor Combinations	1-6
<i>SureServo™</i> AC Servo Drive Control Modes	1-7
<i>SureServo™</i> AC Servo System Specifications	1-8
Drive Specifications	1-8
Motor Specifications	1-10
Motor Velocity-Torque Curves	1-12
Motor Overload Characteristics	1-13

Manual Overview

Overview of This Publication

The *SureServo™* AC Servo Systems User Manual describes the installation, wiring, configuration, inspection, and operation of the *SureServo™* series AC servo drives and motors.

Who Should Read This Manual

This manual contains important information for people who will install, configure, maintain, and/or operate any of the *SureServo™* series AC servo systems.

Supplemental Publications

The National Electrical Manufacturers Association (NEMA) publishes many different documents that discuss standards for industrial control equipment. Global Engineering Documents handles the sale of NEMA documents. For more information, you can contact Global Engineering Documents at:

**15 Inverness Way East
Englewood, CO 80112-5776
1-800-854-7179 (within the U.S.)
303-397-7956 (international)
www.global.ihs.com**

NEMA documents that might assist with your AC servo systems are:

- **NEMA ICS 16 - Motion/Position Control Motors, Controls, and Feedback Devices**

Technical Support

By Telephone: 770-844-4200
(Mon.-Fri., 9:00 a.m.-6:00 p.m. E.T.)

On the Web: www.automationdirect.com

Our technical support group is glad to work with you in answering your questions. If you cannot find the solution to your particular application, or, if for any reason you need additional technical assistance, please call technical support at **770-844-4200**. We are available weekdays from 9:00 a.m. to 6:00 p.m. Eastern Time (U.S.A.). We also encourage you to visit our web site where you can find technical and non-technical information about our products and our company. Visit us at **www.automationdirect.com**.

Special Symbols



When you see the “notepad” icon in the left-hand margin, the paragraph to its immediate right will be a special note.



When you see the “exclamation mark” icon in the left-hand margin, the paragraph to its immediate right will be a **WARNING**. This information could prevent injury, loss of property, or even death (in extreme cases).

SureServo™ AC Servo Systems Introduction

SureServo™ Basic Overview

Traditional Command Sources

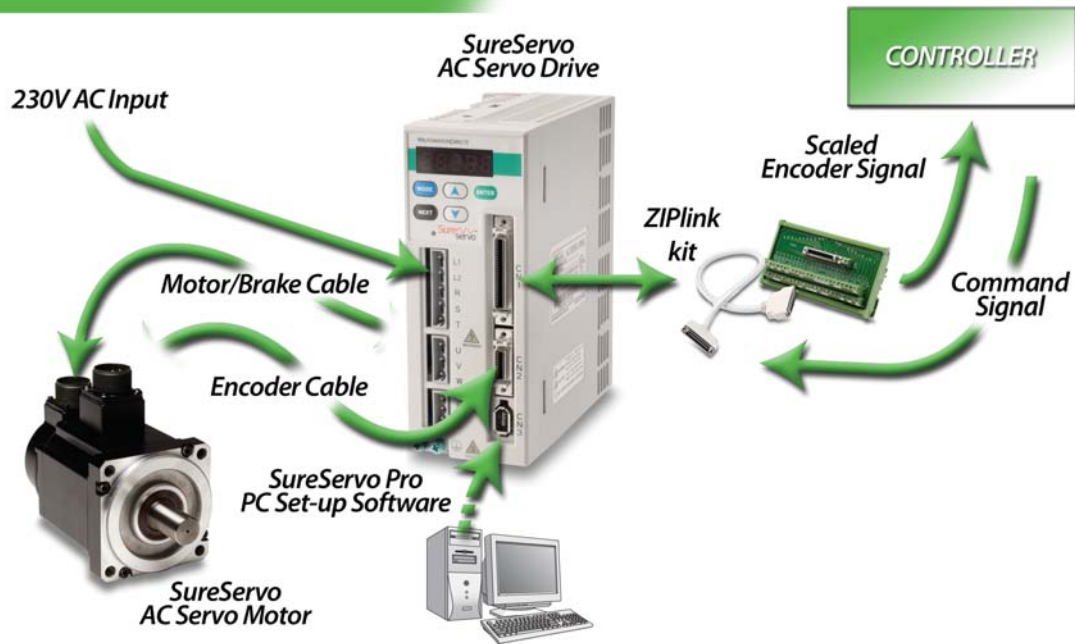

The SureServo AC servo systems range in size from 100W to 3kW continuous power and provide up to 26.4 ft-lbs of peak torque. They can be powered with single or three-phase 230 VAC. The SureServo drives can be controlled in position, velocity, or torque mode. All SureServo motor sizes are available with or without a 24 VDC holding brake. Standard cable sets from 10 to 60 feet in length are available.

Precise Positioning

SureServo systems are easily controlled via 'step & direction,' 'step-up/step-down,' or quadrature encoder input commands from any PLC with a high-speed output. Electronic gearing can be used to scale the incoming pulse frequency from the PLC. This allows the pulses from the PLC to command the exact amount of movement required for a specific application.

On-board Internal Indexer allows the programming of up to eight unique motion profiles.

Digital inputs can be used to initiate any of these profiles. The built-in MODBUS interface offers the flexibility of downloading an unlimited number of customized motion profiles to the drive as they are needed. These profiles can be selected based on additional MODBUS commands or via digital inputs.

Complete Control

Eight programmable inputs and five programmable outputs assure real-time connectivity with any control system. Velocity and torque can be controlled with a $\pm 10V$ analog input signal or with the onboard Internal Indexer. Two analog outputs are available and configurable for monitoring purposes.

When using the *SureServo* traditional command interface ($\pm 10V$ analog signal or high speed pulse output), all programming is performed in the PLC. Many of the PLCs available from AutomationDirect offer some form of high-speed pulse output. Even the DL05 (DC output) includes a single 7kHz high-speed output which can be used for limited motion control applications.

The *SureServo's* ability to download custom motion profiles from a PLC on the fly, and execute these moves on command, allows the ultimate in flexibility and control with a PLC-based motion controller.

Tune-up and Tune-in

Three tuning modes include: manual, adaptive easy-tune, and adaptive auto-tune. The adaptive modes allow the drive to adapt to dynamic load conditions during operation with little or no initial set-up required.

Communication

The *SureServo* drive parameters can be changed from the drive's built-in keypad, or from *SureServo Pro*[™] configuration software. *SureServo* drives can also communicate via a MODBUS interface across RS-232, RS-422 or RS-485 serial links. Multiple *SureServo* systems can be controlled via a single MODBUS port on the PLC. The MODBUS link can also supply information back to the controller about the performance and status of the servo motor and drive systems.

Unpacking Your New *SureServo*

After receiving the AC servo system, please check for the following:

- Make sure that the package includes all of the contents:
 - AC servo drive, connectors, and installation sheet -or-
 - AC servo motor and installation sheet -or-
 - AC servo drive wiring tool.
 - AC servo cable.
- Inspect the units to insure that they were not damaged during shipment.
- Make sure that the part numbers indicated on the component nameplates correspond with the part numbers of your order.
- Make sure that the servo motor shaft rotates normally. Rotate the shaft by hand, and it should rotate easily. The shaft will not turn on motors with the brake option, unless the brake is released by proper application of a 24 VDC supply.
- Make sure that all screws are securely tightened.

Nameplate Information

Example of servo drive nameplate:

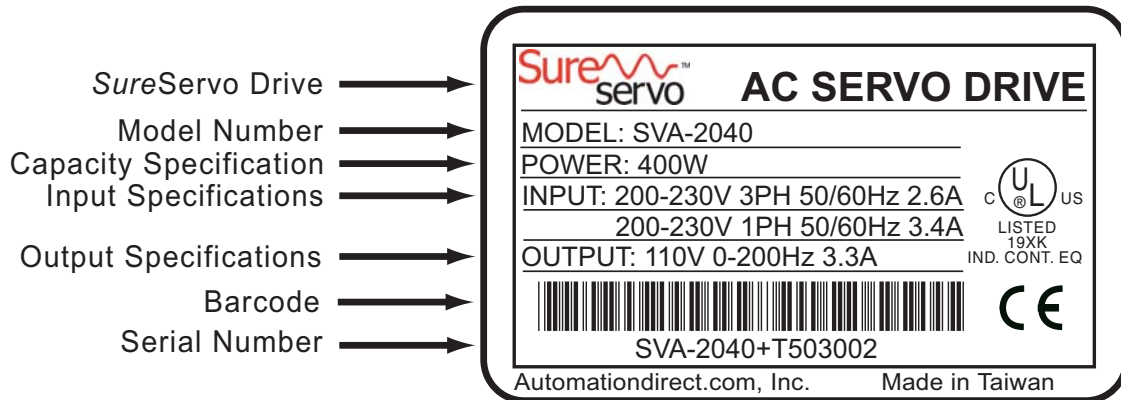

Example of servo motor nameplate:

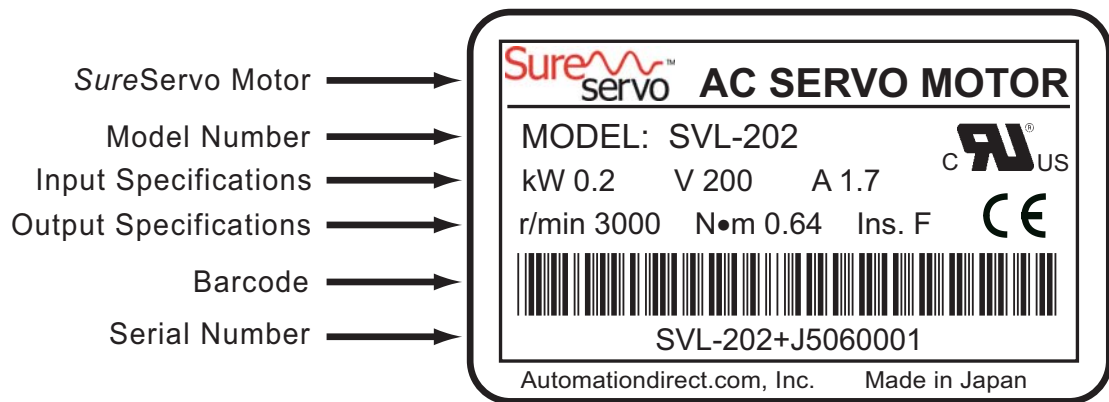

Model Explanation

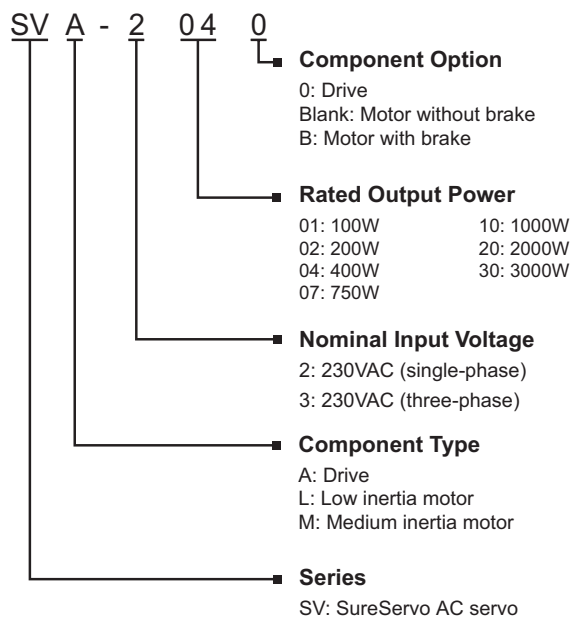

Identification and Labeling: SureServo™ AC Servo Drive

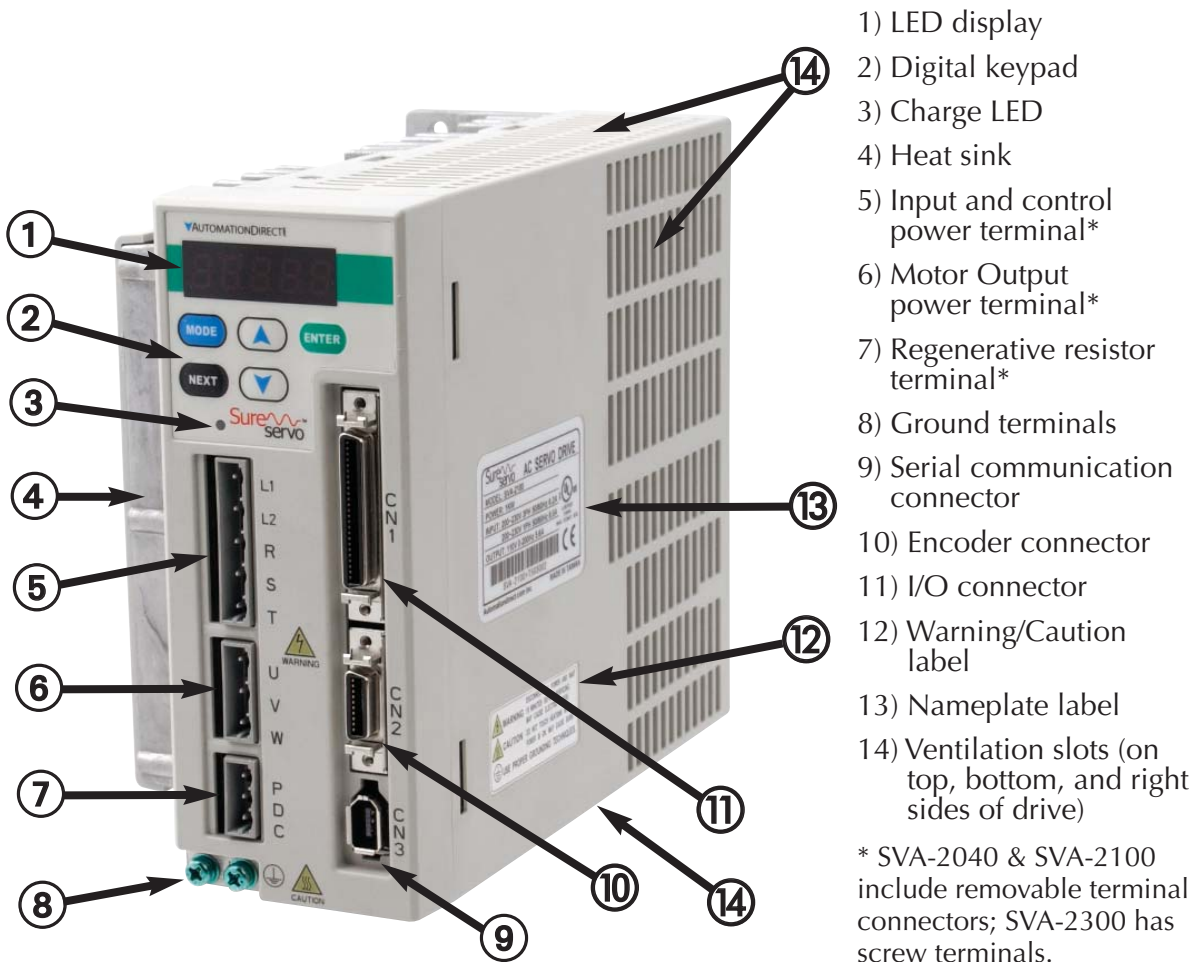

- 1) LED display
 - 2) Digital keypad
 - 3) Charge LED
 - 4) Heat sink
 - 5) Input and control power terminal*
 - 6) Motor Output power terminal*
 - 7) Regenerative resistor terminal*
 - 8) Ground terminals
 - 9) Serial communication connector
 - 10) Encoder connector
 - 11) I/O connector
 - 12) Warning/Caution label
 - 13) Nameplate label
 - 14) Ventilation slots (on top, bottom, and right sides of drive)
- * SVA-2040 & SVA-2100 include removable terminal connectors; SVA-2300 has screw terminals.

Drive and Motor Combinations

Drive and Motor Combinations					
Inertia	Power	Servo drive *	Servo motor (no brake)	Servo motor (with brake)	Motor Code *
Low inertia	100W	SVA-2040	SVL-201	SVL-201B	10 (default)
	200W		SVL-202	SVL-202B	11
	400W		SVL-204	SVL-204B	12
	750W	SVA-2100	SVL-207	SVL-207B	20 (default)
	1000W		SVL-210	SVL-210B	21
Medium inertia	1000W	SVA-2300	SVM-210	SVM-210B	22
	2000W		SVM-220	SVM-220B	30 (default)
	3000W		SVM-230	SVM-230B	31



***WARNING:** To prevent damage to the servo system, be sure to set the servo drive parameter 1.31 to the proper motor code before running the motor.

SureServo™ AC Servo Drive Control Modes

The SureServo drive can be configured to provide six single and five dual control modes, as shown in the table below. These control modes can be set by parameter P1-01. If the control mode is changed, the drive must be powered off and back on again (power cycled) before the new modes will become active.

All preset values (speed, position, torque) are addressable via MODBUS, giving an unlimited number of setpoints.

Drive Control Modes			
Control Mode	Code	Description	
Single Mode	External Position	Pt	Position control achieved by an external pulse signal command.
	Internal Position	Pr	Position control achieved from up to eight commands stored within the drive and selected by digital input (DI) signals.
	Velocity	V	Velocity (speed) control achieved either by an external analog signal (-10 to +10Vdc), or by parameters set within the drive and selected by digital input (DI) signals. (Up to three speeds can be stored internally.)
	Internal Velocity	Vz	Velocity (speed) control achieved only by parameters set within the drive and selected by digital input (DI) signals. (Up to three speeds can be stored internally.)
	Torque	T	Torque control achieved either by an external analog signal (-10 to +10Vdc), or by parameters set within the drive and selected by digital input (DI) signals. (Up to three torque levels can be stored internally.)
	Internal Torque	Tz	Torque control achieved only by parameters set within the drive and selected by digital input (DI) signals. (Up to three torque levels can be stored internally.)
Dual Mode	External Position - Velocity	Pt-S	Either Pt or S control can be selected by digital input (DI) signals.
	External Position - Torque	Pt-T	Either Pt or T control can be selected by digital input (DI) signals.
	Internal Position - Velocity	Pr-S	Either Pr or S control can be selected by digital input (DI) signals.
	Internal Position - Torque	Pr-T	Either Pr or T control can be selected by digital input (DI) signals.
	Velocity - Torque	S-T	Either S or T control can be selected by digital input (DI) signals.

SureServo™ AC Servo System Specifications

Drive Specifications

General Drive Specifications	
Permissible Frequency	50 / 60Hz ±5%
Encoder Resolution / Feedback Resolution	2500 lines / 10000 ppr
Control of Main Circuit	SVPWM (Space Vector Pulse Width Modulation) Control
Tuning Modes	Easy / Auto / Manual
Dynamic Brake	Built-in control
Analog Monitor Outputs (2)	Monitor signal can be set by parameters (Output voltage range: ±8V)
8 Programmable Digital Inputs (45 selectable functions)	Servo enable, Alarm reset, Gain switching, Pulse counter clear, Fault Stop, CW/CCW overtravel
	Internal parameter selection, Torque limit activation, Velocity limit activation, Control mode selection
Scalable Encoder Output	Encoder signal output A, /A, B, /B, Z /Z, Line Driver
5 Programmable Outputs (9 selectable indicators)	Servo ready, Servo On, Low Velocity, Velocity reached, In Position, Torque limiting, Servo fault, Electromagnetic brake control, Home search completed
Communication Interface	RS-232 / RS-485 / RS-422 / Modbus ASCII & RTU up to 115k Baud
Protective Functions	Overcurrent, Overvoltage, Undervoltage, Overload, Excessive velocity/position error, Encoder error, Regeneration error, Communication error
Installation Site	Indoor location (free from direct sunlight), no corrosive liquid and gas (far away from oil mist, flammable gas, dust)
Altitude	Altitude 1000m or lower above sea level
Operating Temperature	0 to 55°C (If operating temperature is above 50° C (131°F), forced cooling will be required)
Storage Temperature	-20° to 65°C (-4° to 149°F)
Humidity	0 to 90% (non-condensing)
Vibration	9.81m/s ² (1G) less than 20Hz, 5.88m/s ² (0.6G) 20 to 50Hz
Protection	IP 20
Agency Approvals	CE; UL listed (U.S. and Canada)



For long-term reliability, the ambient temperature of SureServo systems should be under 45° C (143° F).

Model and Mode Specific Drive Specifications					
	AC Servo Model		SVA-2040	SVA-2100	SVA-2300
	Voltage Phase		Single-phase or Three-phase		Three-phase
	Voltage & Frequency Range		3 ϕ : 170~255V @ 50/60Hz \pm 5% 1 ϕ : 200~255V @ 50/60Hz \pm 5%		170~255V 50/60Hz \pm 5%
	Main Circuit Input Current ¹	Single Phase	3.4A @ 400W	8.0A @ 1kW	-
		Three Phase	2.6A @ 400W	6.2A @ 1kW	13.6A @ 3kW
	Main Circuit Inrush Current		44A	77A	87A
	Main Circuit Power Cycling		maximum 1 power cycle per minute		
	Control Circuit Current & Voltage ¹		43mA @ 200~255Vac 1 ϕ		
	Control Circuit Inrush Current		32A maximum		
	Cooling System		Natural Air Circ.	Internal Cooling Fan	
Weight		1.5kg	2.0kg	3.0kg	
Position Control Mode	Max. Input Pulse Frequency		Max. 500kPPS (Line driver); Max. 200kPPS (Open collector)		
	Pulse Type		Pulse + Direction, A phase + B phase Quadrature, CCW pulse + CW pulse		
	Command Source		External pulse train / Onboard indexer		
	Smoothing Strategy		Low-pass and P-curve filter		
	Electronic Gear		Electronic gear N/M multiple N: 1~32767, M: 1~32767(1/50<N/M<200)		
	Torque Limit Operation		Set by parameters or by analog input		
	Feed Forward Compensation		Set by parameters		
Velocity Control Mode	Analog Input Command	Voltage Range	Bipolar \pm 10 VDC		
		Input Resistance	10k Ω		
		Time Constant	2.2 μ s		
	Speed Control Range		1:5000		
	Command Source		External analog signal / Onboard indexer		
	Smoothing Strategy		Low-pass and S-curve filter		
	Torque Limit Operation		Set by parameters or via analog input		
	Frequency Response Characteristic		Maximum 450Hz		
	Speed Accuracy (at rated rotation speed)		0.01% or less at 0 to 100% load fluctuation		
0.01% or less at \pm 10% power fluctuation					
0.01% or less at 0 to 50°C ambient temperature fluctuation					
Torque Control Mode	Analog Input Command	Voltage Range	Bipolar \pm 10 VDC		
		Input Resistance	10k Ω		
		Time Constant	2.2 μ s		
	Permissible Time for Overload		8 sec. under 200% rated output		
	Command Source		External analog signal / Onboard indexer		
	Smoothing Strategy		Low-pass filter		
	Speed Limit Operation		Set by parameters or via analog input		
<i>Note 1: Refer to Chapter 3 for recommended circuit protection information.</i>					

Motor Specifications

Motor Specifications										
Inertia Range		Low					Medium			
Model Name: SVx-xxx		SVL- 201	SVL- 202	SVL- 204	SVL- 207	SVL- 210	SVM- 210	SVM- 220	SVM- 230	
Rated output power	W	100	200	400	750	1000	1000	2000	3000	
	N·m	0.318	0.64	1.27	2.39	3.3	4.8	9.4	14.3	
Rated torque	lb·in	2.8	5.7	11.2	21.2	29.2	42.5	83.2	125.7	
	N·m	0.95	1.91	3.82	7.16	9.9	15.7	23.5	35.8	
Maximum torque	lb·in	8.4	16.9	33.8	63.4	87.6	138.9	208.0	316.8	
	rpm	3000					2000			
Max. speed	rpm	5000			4500		3000			
Rated current	A	1.1	1.7	3.3	5.0	6.8	5.6	13.1	17.4	
Max. current	A	3.0	4.9	9.3	14.1	18.7	17.6	31.4	42.3	
Drive input current	1φ A	1.0	1.7	3.4	5.9	8.0	8.0	-		
	3φ A	0.8	1.3	2.6	4.7	6.2	6.2	9.1	13.6	
Max. radial shaft load	N	78.4	196		343	490		784		
	lb	18	44		77	110		176		
Max. thrust shaft load	N	39.2	68.6		98			392		
	lb	9	15		22			88		
Brake (SVx-xxxB only)	Voltage	VDC	24							
	Current	ADC	0.21	0.38		0.4	0.75	0.83	1.45	1.67
	Holding Torque	N·m	0.32	1.27		2.55	9.3	7.5	32.0	50.0
lb·in		2.83	11.24		22.57	82.3	66.38	283.2	442.5	
Rotor inertia w/o brake	kg·m ²	0.03E-4	0.18E-4	0.34E-4	1.08E-4	2.6E-4	5.98E-4	15.8E-4	43.3E-4	
	lb·in·s ²	0.27E-4	1.59E-4	3.0E-4	9.56E-4	23.0E-4	52.9E-4	139.8E-4	383.2E-4	
Rotor inertia with brake	kg·m ²	0.06E-4	0.28E-4	0.44E-4	1.32E-4	3.1E-4	8.8E-4	27.8E-4	56.3E-4	
	lb·in·s ²	0.53E-4	2.48E-4	3.9E-4	11.7E-4	27.4E-4	77.9E-4	246.0E-4	498.3E-4	
Mechanical time constant	ms	0.6	0.9	0.7	0.6	1.7	1.4	1.6	0.9	
Static friction torque	N·m	0.02	0.04		0.08	0.49	0.29	0.98		
Torque constant-KT	N·m/A	0.32	0.39	0.4	0.5	0.56	0.91	0.77	0.86	
Voltage constant-KE	V/rpm	33.7E-3	41.0E-3	41.6E-3	52.2E-3	58.4E-3	95.71E-3	81.1E-3	90.5E-3	
Armature resistance	Ω	20.3	7.5	3.1	1.3	2.052	1.98	0.6	0.162	
Armature inductance	mH	32	24	11	6.3	8.4	13.2	6.1	2.3	

Motor Specifications table continued next page.

Motor Specifications (continued)									
Inertia Range		Low					Medium		
Model Name: SVx-xxx		SVL -201	SVL -202	SVL -204	SVL -207	SVL -210	SVM -210	SVM -220	SVM -230
Electrical time constant	ms	1.6	3.2	3.2	4.8	4.1	6.7	10.1	14.2
Motor Type*	Brushless, AC, permanent magnet								
Insulation class	Class F								
Insulation resistance	>100MΩ , 500VDC								
Insulation strength	1500 VAC, 50Hz, 60 seconds								
Ambient temperature range	0 to 40°C (32°F to 104°F)								
Operating temperature (measured case temp)	70°C (158°F)								
Maximum operating temperature (measured case temp)	70°C + 40°C = 110°C (230°F)								
Storage temperature	-20 to 65°C (-4 to 149°F)								
Operating humidity	20 to 90% RH (non-condensing)								
Storage humidity	20 to 90% RH (non-condensing)								
Vibration / Shock	2.5G / 5.0G								
Environmental rating	IP65 motor body; IP40 shaft; IP20 connector					IP65 (requires <i>SureServo</i> cables)			
Weight without brake	kg	0.5	0.9	1.3	2.5	4.7	4.8	12.0	17.0
	lb	1.1	1.98	2.87	5.5	10.36	10.58	26.46	37.48
Weight with brake	kg	0.7	1.4	1.8	3.4	6.3	7.5	19.0	24.0
	lb	1.54	3.09	3.97	7.5	13.89	16.53	41.89	52.9
Agency Approvals	CE; UL recognized (U.S. and Canada)								
NOTE: U.S. customary units are for reference only.									

* Motor employs rare earth magnets composed of Neodymium (Nd), Iron (Fe), and Boron (B).

Motor Velocity-Torque Curves

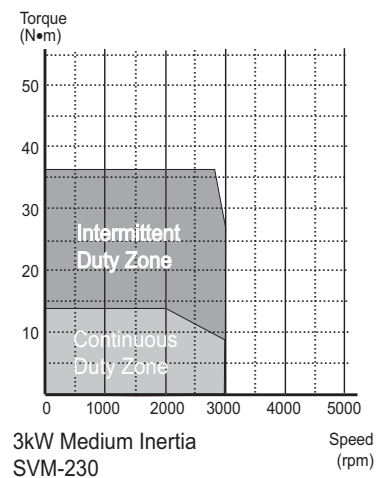
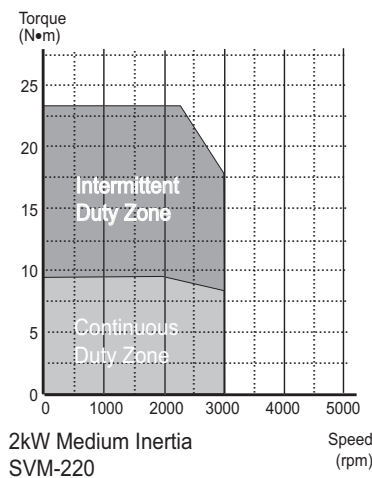
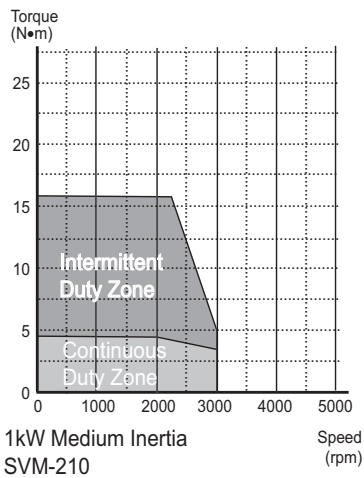
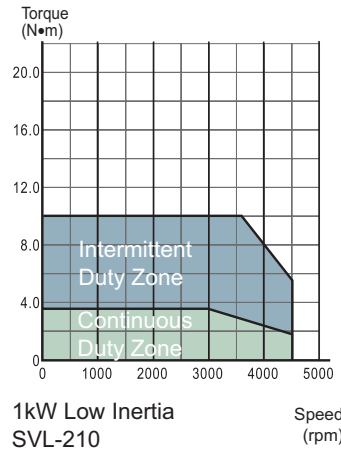
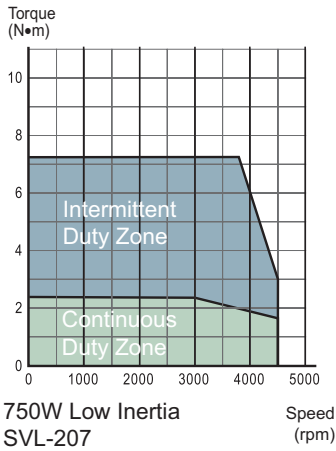
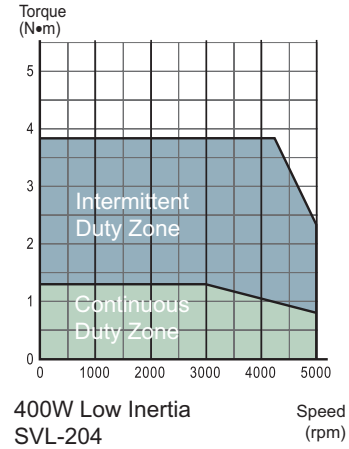
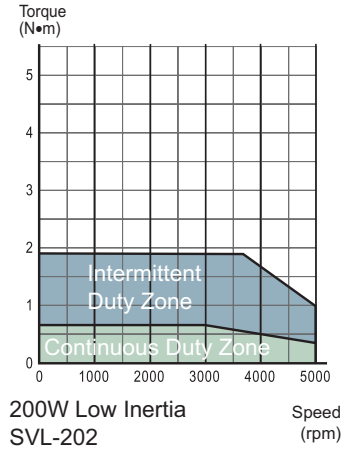
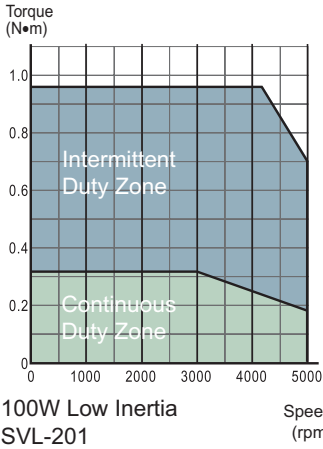

Motor Overload Characteristics

Overload Protection Function

Overload protection is a built-in protective function to prevent a motor from overheating.

Common Overload Causes and Conditions

1. Servo system operated for several seconds above 100% torque.
2. Frequent acceleration/deceleration cycles of high inertia loads.
3. The power cable or encoder cable not making a solid connection.
4. Improper or aggressive tuning adjustments, causing motor vibration, noise, and/or overheating.
5. Trying to run the system without releasing the internal holding brake on brake motors.

Load and Operating Time

SVL-201, SVL-202, SVL-204, SVL-207

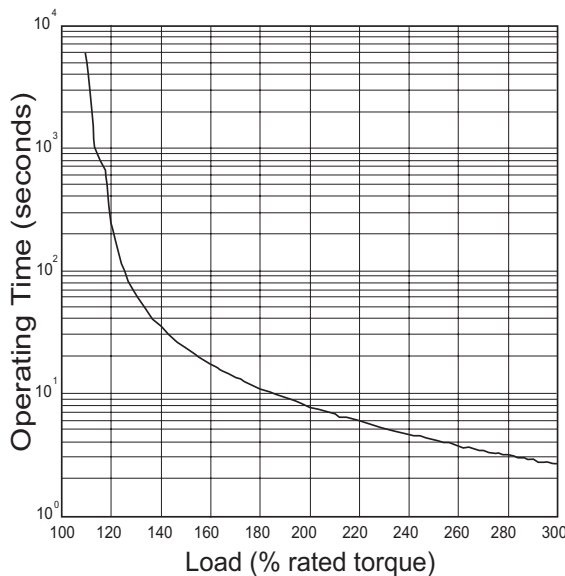

SVM-210, SM-220, SVM-230

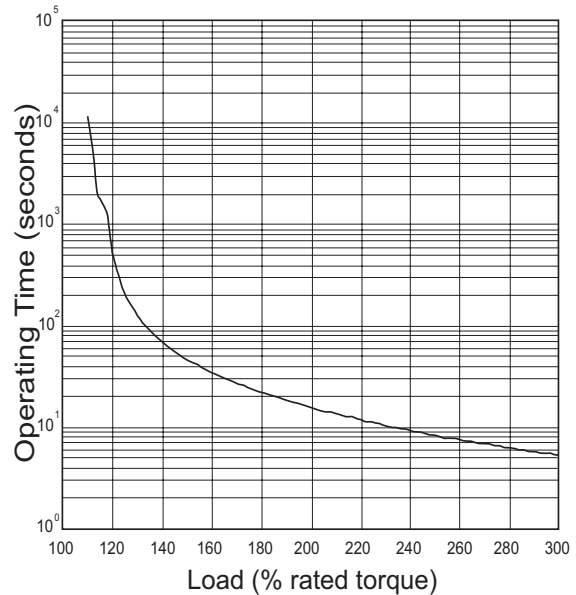

Load	Operating Time
120%	263.8 s
140%	35.2 s
160%	17.6 s
180%	11.2 s
200%	8 s
220%	6.1 s
240%	4.8 s
260%	3.9 s
280%	3.3 s
300%	2.8 s

Load	Operating Time
120%	527.6 s
140%	70.4 s
160%	35.2 s
180%	22.4 s
200%	16 s
220%	12.2 s
240%	9.6 s
260%	7.8 s
280%	6.6 s
300%	5.6 s