

**SURESTEP™**  
**STEPPING MOTORS**

---



**CHAPTER**  
**4**

**In This Chapter...**

Features . . . . .	.4-2
Design and Installation Tips . . . . .	.4-2
Specifications . . . . .	.4-3
Power Supply and Step Motor Drive . . . . .	.4-4
Mounting the Motor . . . . .	.4-4
Connecting the Motor . . . . .	.4-4
Extension Cable Wiring Diagram . . . . .	.4-4
Motor Dimensions and Cabling . . . . .	.4-5
Torque vs. Speed Charts . . . . .	.4-7

## Features

- Nine step motors in two torque classes and three NEMA frame sizes
- Square frame style produces high torque and achieves best torque to volume ratio
- Holding torque ranges from 61 to 1292 oz·in
- NEMA 17, 23 and 34 mounting flange frame sizes
- 4-wire, 12" long connectorized pigtail
- Optional 20 foot extension cable with locking connector available

**NEMA 17**



**NEMA 23**



**NEMA 34**



**Motor Extension Cable**



## Design and Installation Tips

Allow sufficient time to accelerate the load and size the step motor with a 100% torque safety factor. DO NOT disassemble step motors because motor performance will be reduced and the warranty will be voided. DO NOT connect or disconnect the step motor during operation. Mount the motor to a surface with good thermal conductivity, such as steel or aluminum, to allow heat dissipation. Use a flexible coupling with "clamp-on" connections to both the motor shaft and the load shaft to prevent thrust loading on bearings from minor misalignment.

## Specifications

SureStep™ Series Specifications – Connectorized Bipolar Stepping Motors										
Bipolar Stepping Motors		High Torque Motors					Higher Torque Motors			
		STP-MTR-17040	STP-MTR-17048	STP-MTR-23055	STP-MTR-23079	STP-MTR-34066	STP-MTRH-23079	STP-MTRH-34066	STP-MTRH-34097	STP-MTRH-34127
NEMA Frame Size		17	17	23	23	34	23	34	34	34
Max Holding Torque	(lb-in)	3.84	5.19	10.37	17.25	27.1	17.926	26.738	50.159	80.7356
	(oz-in)	61.4	83	166	276	434	286.81	427.81	802.54	1291.77
	(N-m)	0.44	0.59	1.17	1.95	3.06	2.0253	3.0210	5.6671	9.121
Rotor Inertia	(oz-in <sup>2</sup> )	0.28	0.45	1.483	2.596	7.66	2.60	7.66	14.80	21.90
	(kg-cm <sup>2</sup> )	0.051	0.082	0.271	0.475	1.40	0.476	1.40	2.71	4.006
Rated Current (A/phase)		1.7	2.0	2.8	2.8	2.8	5.6	6.3	6.3	6.3
Resistance (Ω/phase)		1.6	1.40	0.75	1.10	1.11	0.40	0.25	0.30	0.49
Inductance (mH/phase)		3.03	2.65	2.36	3.82	7.70	1.18	1.52	2.07	4.14
Basic Step Angle		1.8°								
Shaft Runout		0.002 in [0.051 mm]								
Max Shaft Radial Play @ 1lb load		0.001 in [0.025 mm]								
Perpendicularity		0.003 in [0.076 mm]								
Concentricity		0.002 in [0.051 mm]								
Maximum Radial Load (lb [kg])		6.0 [2.7]	15.0 [6.8]	39.0 [17.7]	15.0 [6.8]	39.0 [17.7]	15.0 [6.8]	39.0 [17.7]	15.0 [6.8]	39.0 [17.7]
Maximum Thrust Load (lb [kg])		6.0 [2.7]	13.0 [5.9]	25.0 [11.3]	13.0 [5.9]	25.0 [11.3]	13.0 [5.9]	25.0 [11.3]	13.0 [5.9]	25.0 [11.3]
Operating Temperature		-20°C to 50°C [-4°F to 122°F] (motor case temp < 100°C)								
Operating Humidity		55% to 85% non-condensing								
Weight (lb [kg])		0.7 [0.3]	1.5 [0.68]	2.2 [1.0]	3.9 [1.8]	2.3 [1.0]	3.8 [1.7]	6.1 [2.8]	8.8 [4.0]	8.8 [4.0]
Insulation Class		130°C [266°F] Class B								
Agency Approval		CE (complies with EN55014-1 (1993) and EN60034-1.5.11)								
Accessory Extension Cable		STP-EXT-020					STP-EXTH-020			

## Power Supply and Step Motor Drive

An STP-PWR-xxxx series power supply from AutomationDirect is the best choice to power AutomationDirect and other step motors. These power supplies were designed to work with the AutomationDirect *SureStep™* STP-DRV-xxxx series bipolar microstepping motor drives.

## Mounting the Motor

We recommend mounting the motor to a metallic surface to help dissipate heat generated by the motor.

## Connecting the Motor



**WARNING:** When connecting a step motor to a drive or indexer, be sure that the motor power supply is switched off. Never disconnect the motor while the drive is powered up. Never connect the motor leads to ground or directly to the power supply.

All *SureStep* step motors have four-wire connectorized pigtail cables which connect directly to available *SureStep* 20" extension cables. Due to the different current ranges of the two motor torque classes, two different cables are available with two different current capacities. The ...MTR... motors use ...EXT... cables, and the ...MTRH... motors use ...EXTH... cables. The extension cables have the same wire color coding as the motor pigtail cables, as shown in the extension cable wiring diagram and in the motor dimension and cabling diagram.

### Extension Cable Wiring Diagram

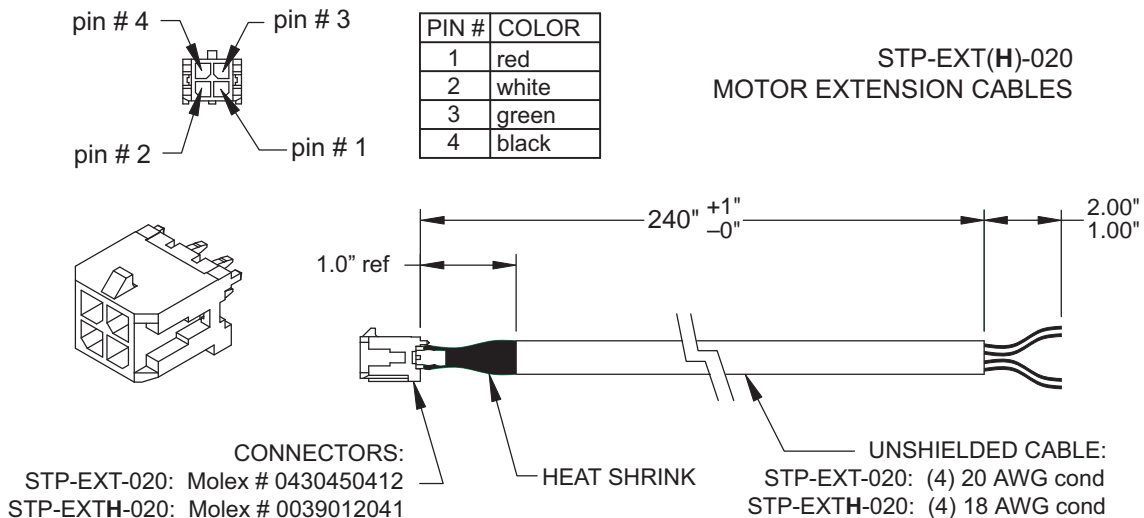

# Motor Dimensions and Cabling

Typical Dimension and Cable Diagram for STP-MTR(H)-xxxxx Step Motors

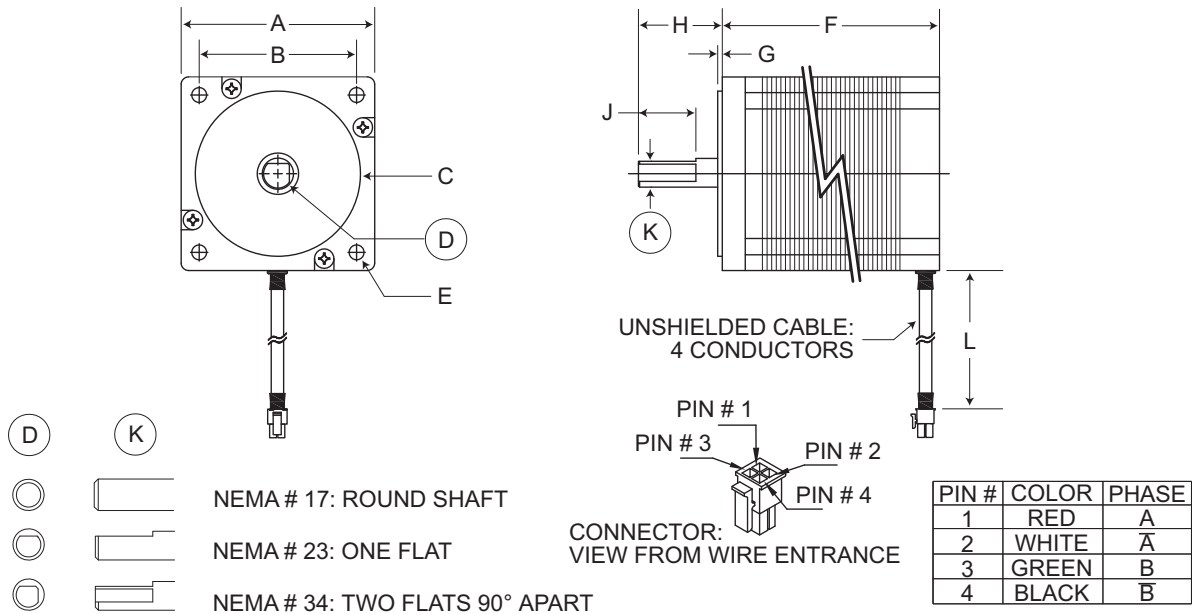

SureStep™ Series Dimensions & Cabling – STP-MTR-xxxxx** Step Motors					
Dimensions (in [mm])*	High Torque Motors STP-MTR-xxxxx**				
	STP-MTR -17040	STP-MTR -17048	STP-MTR -23055	STP-MTR -23079	STP-MTR-34066
A	1.67 [42.42]	1.66 [42.16]	2.25 [57.15]		3.37 [85.60]
B	1.22 [30.99]		1.86 [47.24]		2.74 [69.60]
C	Ø 0.866 [22.00] +0.000/-0.002		Ø 1.500 [38.10] ±0.001		Ø2.875[73.03]±0.001
D	Ø 0.1968 [5.00] +0.0000/-0.0005		Ø 0.2500 [6.35] +0.0000/-0.0005		Ø 0.5000 [12.70] +0.0000/-0.0005
E	M3 x 0.5 thread 0.15 [3.81] min depth		Ø 0.20 [5.08] through		Ø 0.26 [6.60] through
F	1.58 [40.13]	1.89 [48.00]	2.17 [55.12]	3.10 [78.74]	2.60 [66.04]
G	0.08 [2.03]		0.06 [1.52]		0.08 [2.03]
H	0.94 [23.88] ±0.02		0.81 [20.57] ±0.02		1.46 [37.08] ±0.04
J	n/a		0.59 [14.99]		1.00 [25.40]
K	n/a		0.230 [5.84]		0.450 [11.43] ±0.006
L	12 [305] +0.5/-0.0	12.0 [305]			
Conductor	(4) #20 AWG				
Connector	Molex # 43025-0400				
Pin	Molex # 43030-0007				

\* mm dimensions are for reference purposes only.  
 \*\* Higher Torque STP-MTRH-xxxxx motors are shown in a separate table.

Typical Dimension and Cable Diagram for STP-MTR(H)-xxxxx Step Motors

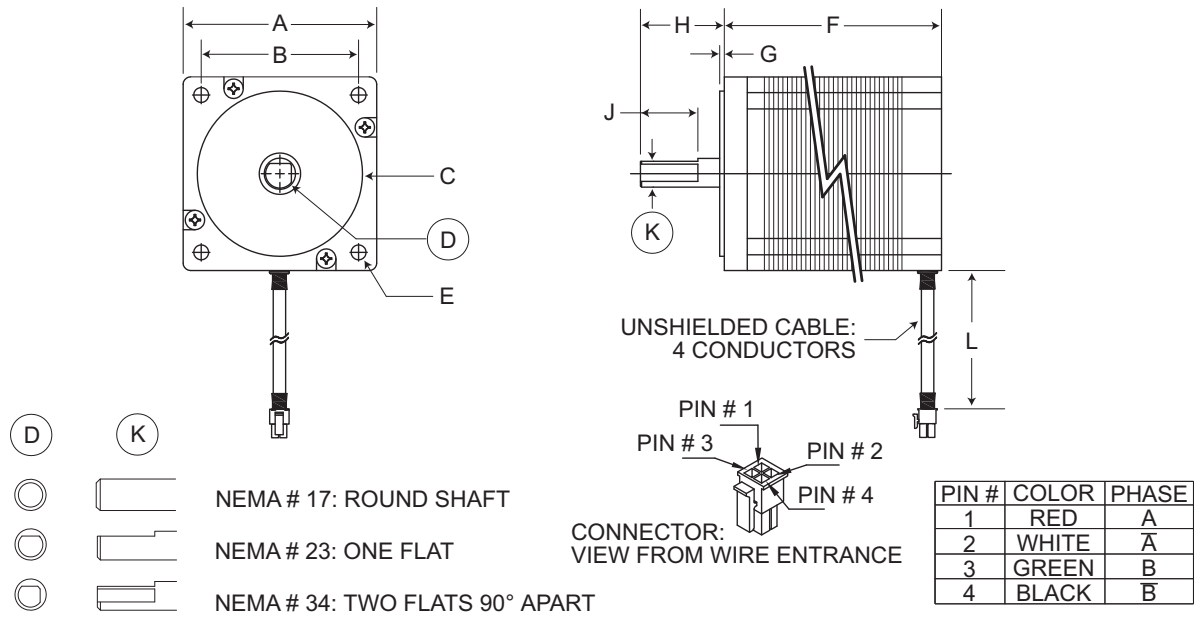

SureStep™ Series Dimensions & Cabling – STP-MTRH-xxxxx** Step Motors				
Dimensions (in [mm])*	Higher Torque Motors STP-MTRH-xxxxx**			
	STP-MTRH-23079	STP-MTRH-34066	STP-MTRH-34097	STP-MTRH-34127
A	2.25 [57.15]		3.39 [86.11]	
B	1.86 [47.24]		2.74 [69.60]	
C	∅ 1.500 [38.10] ±0.001		∅ 2.875 [73.03] ±0.001	
D	∅ 0.2500 [6.35] +0.0000/-0.0005		∅ 0.5000 [12.70] +0.0000/-0.0005	
E	∅ 0.20 [5.08] through		∅ 0.26 [6.60] through	
F	3.10 [78.74]	2.64 [67.06]	3.82 [97.03]	5.0 [127.0]
G	0.06 [1.52]		0.08 [2.03]	
H	0.81 [20.57] ±0.02		1.46 [37.08] ±0.04	
J	0.59 [14.99]		0.984 [24.99] ±0.010	
K	0.230 [5.84]		0.453 [11.51] ±0.006	
L	12 [305] +0.5/-0.0			
Conductor	(4) #18 AWG			
Connector	Molex # 39-01-3042			
Pin	Molex # 39-00-0039			
* mm dimensions are for reference purposes only.				
** High Torque STP-MTR-xxxxx motors are shown in a separate table.				

## Torque vs. Speed Charts

### STP-MTR-17xxx NEMA 17 Step Motors

**STP-MTR-17040** Torque vs Speed (1.8° step motor; 1/2 stepping)

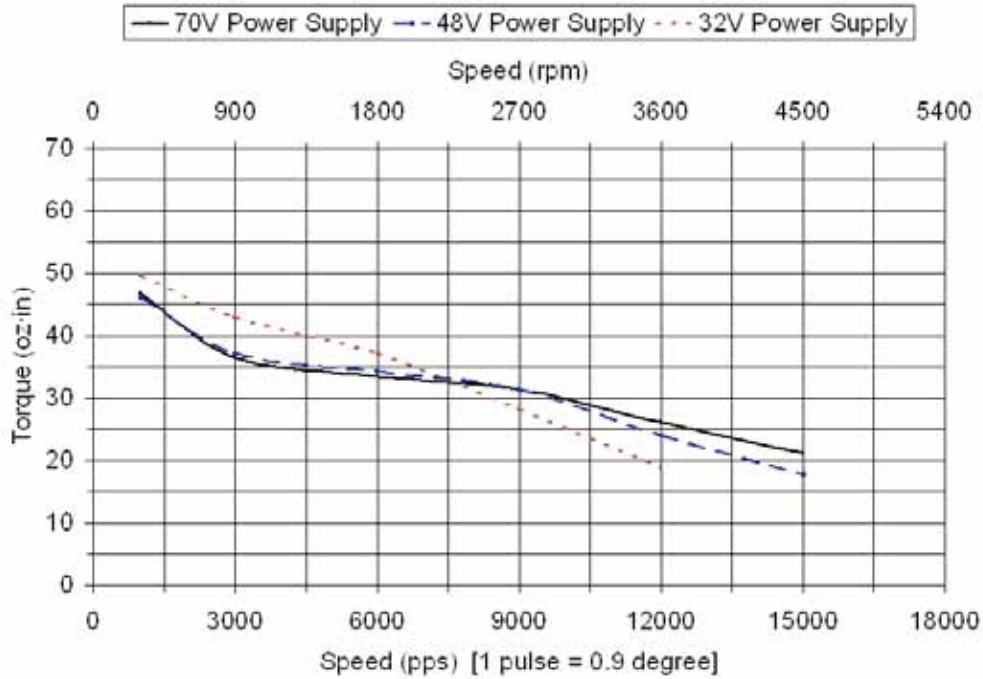

**STP-MTR-17048** Torque vs Speed (1.8° step motor; 1/2 stepping)

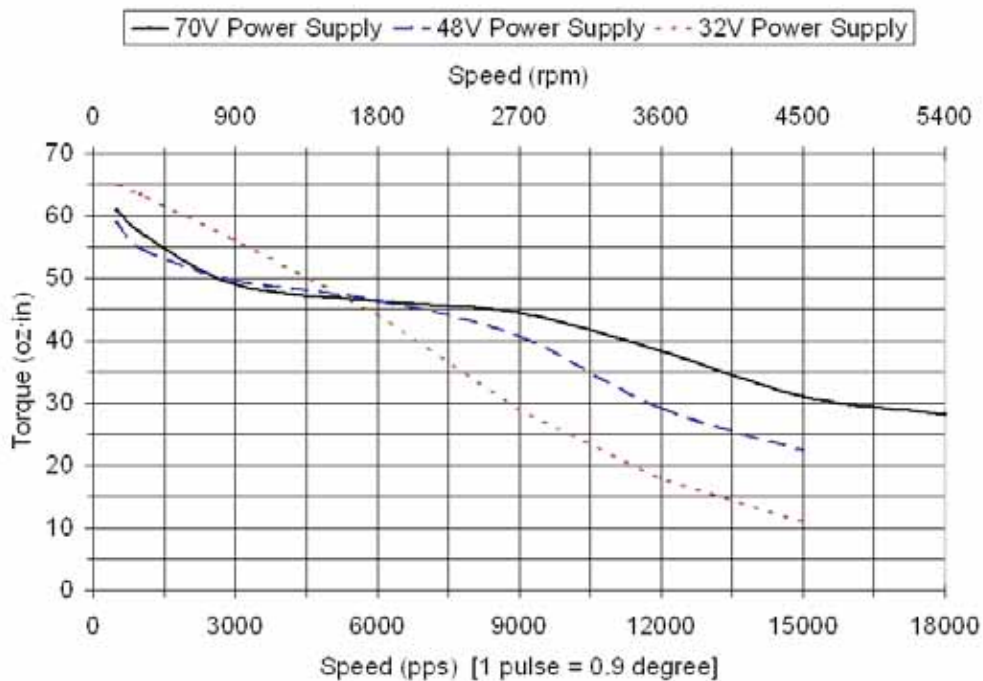

Torque vs. Speed Charts (continued)

STP-MTR(H)-23xxx NEMA 23 Step Motors

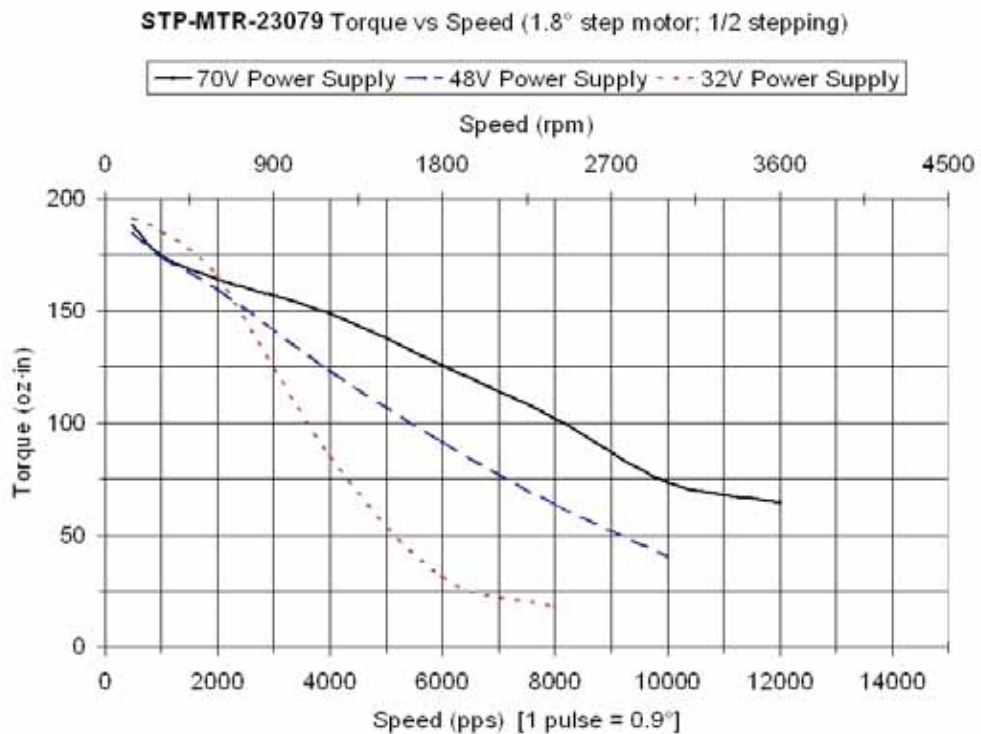
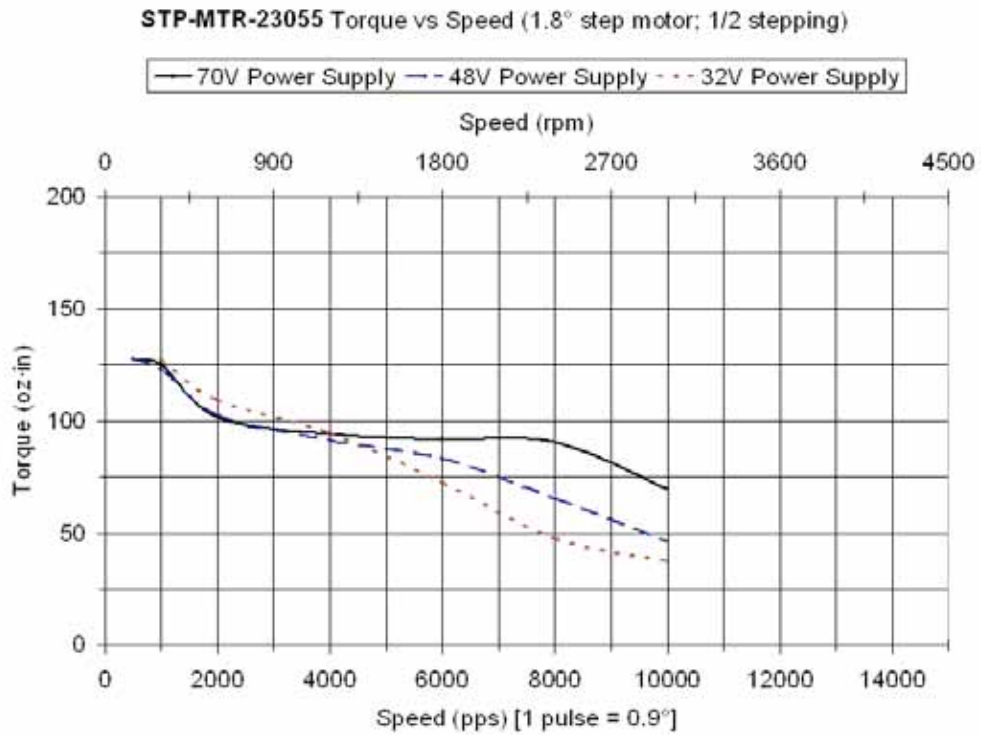

Torque vs. Speed Charts (continued)

STP-MTR(H)-23xxx NEMA 23 Step Motors (continued)

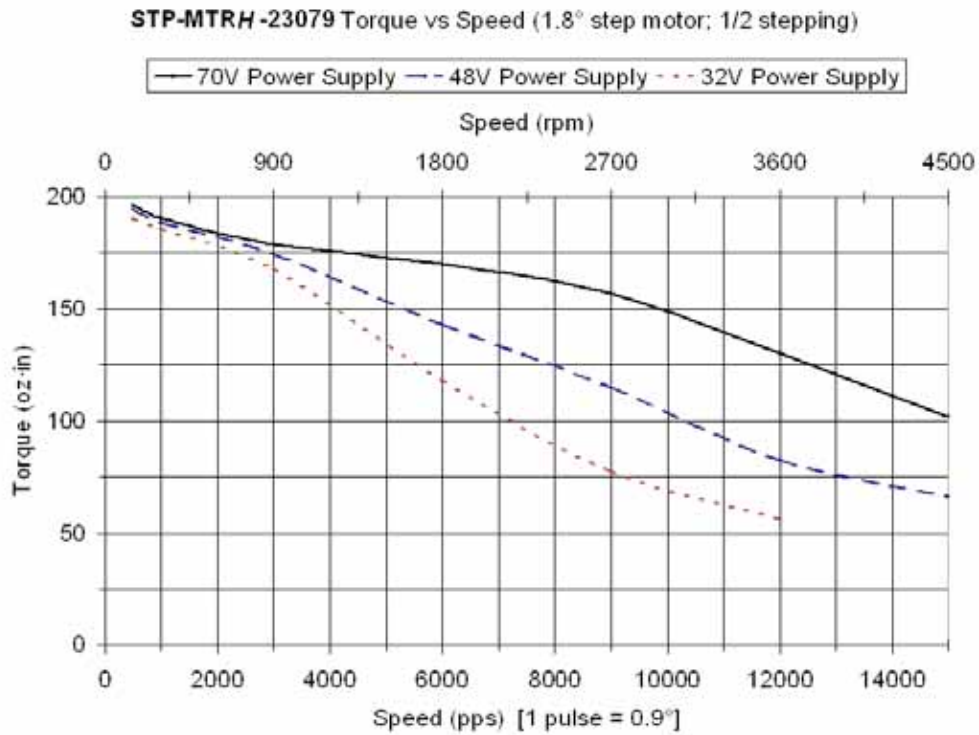

Torque vs. Speed Charts (continued)

STP-MTR(H)-34xxx NEMA 34 Step Motors

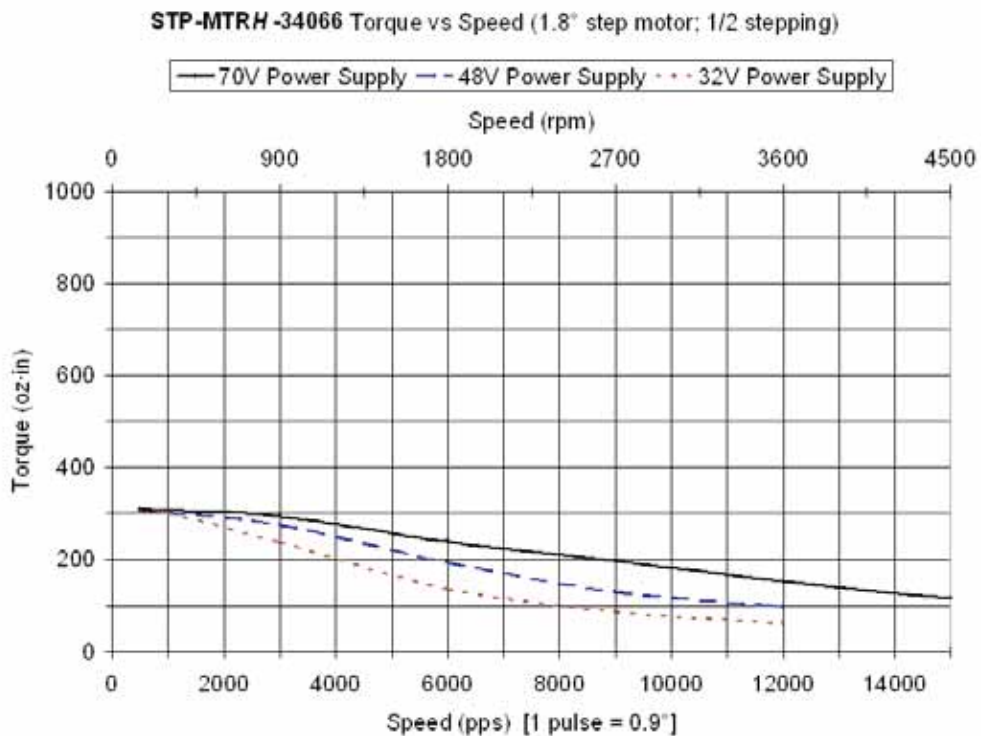
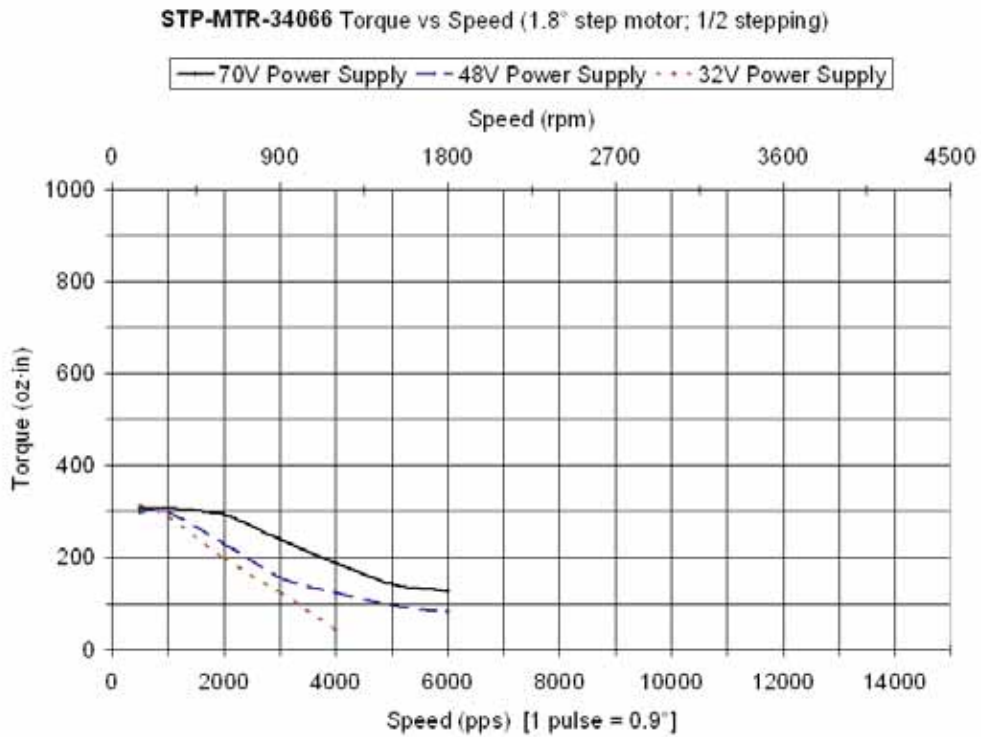

Torque vs. Speed Charts (continued)

STP-MTR(H)-34xxx NEMA 34 Step Motors (continued)

