

Jumper Settings				
DC Output Module	P2	P3	P4	P5
32TD1				
64TD1				
32TD2				
64TD2				

NOTE: Wiring is shown for reference only.

When using this module with any 32 point or 64 point I/O module, all jumpers must be set the same.

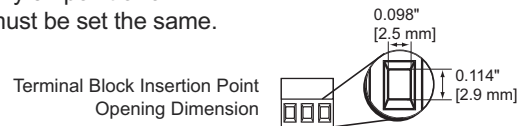

This configuration connects the supply voltage (V) to the load distribution terminals for use with any 32TD1 or 64TD1 PLC I/O modules. All four jumpers must be set the same.

This configuration connects the supply common (0V) to the load distribution terminals for use with any 32TD2 or 64TD2 PLC I/O modules. All four jumpers must be set the same.

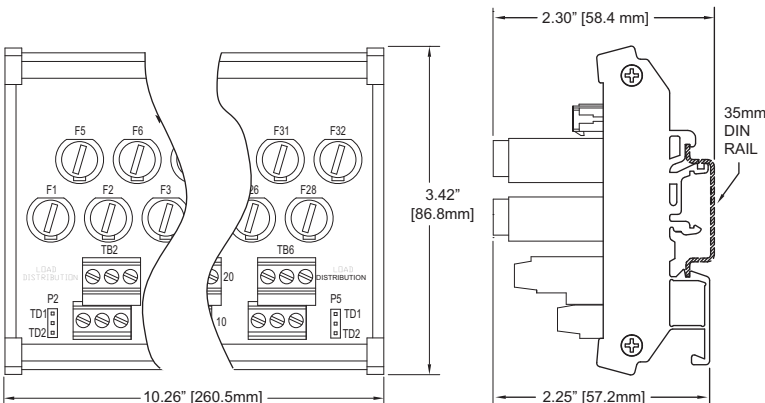

ZL-RFU40 TB1 Pinouts		
Row	Terminal Block 1 Terminal	Connector Fuse Pin
TOP	1	Fuse 5
	2	Fuse 6
	3	Fuse 7
	4	Fuse 8
	5	-----
	6	Fuse 13
	7	Fuse 14
	8	Fuse 15
	9	Fuse 16
	10	-----
BOTTOM	11	Fuse 1
	12	Fuse 2
	13	Fuse 3
	14	Fuse 4
	15	-----
	16	Fuse 9
	17	Fuse 10
	18	Fuse 11
	19	Fuse 12
	20	-----

ZL-RFU40 TB4 Pinouts		
Row	Terminal Block 4 Terminal	Connector Fuse Pin
TOP	1	Fuse 21
	2	Fuse 22
	3	Fuse 23
	4	Fuse 24
	5	-----
	6	Fuse 29
	7	Fuse 30
	8	Fuse 31
	9	Fuse 32
	10	-----
BOTTOM	11	Fuse 17
	12	Fuse 18
	13	Fuse 19
	14	Fuse 20
	15	-----
	16	Fuse 25
	17	Fuse 26
	18	Fuse 27
	19	Fuse 28
	20	-----

Apply ZIPLink Labels

(Supplied with module)

1 Find correct label and remove from sheet

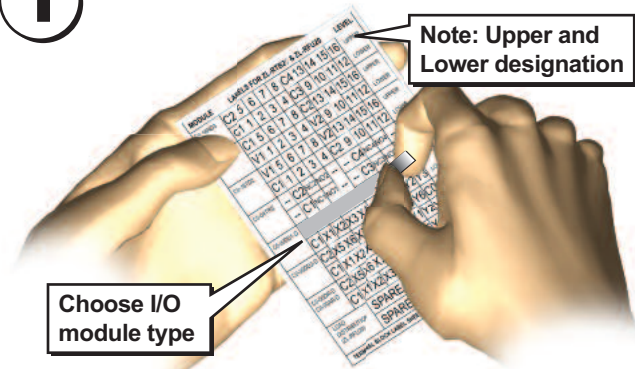

2 Apply label to designated position

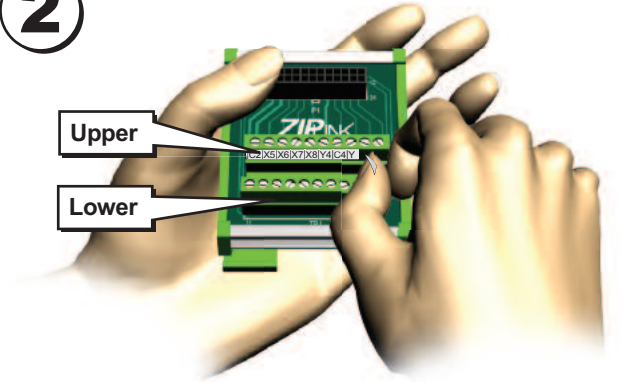

DIN Rail Installation and Removal

To install ZIPLink module, insert upper tab into DIN rail.

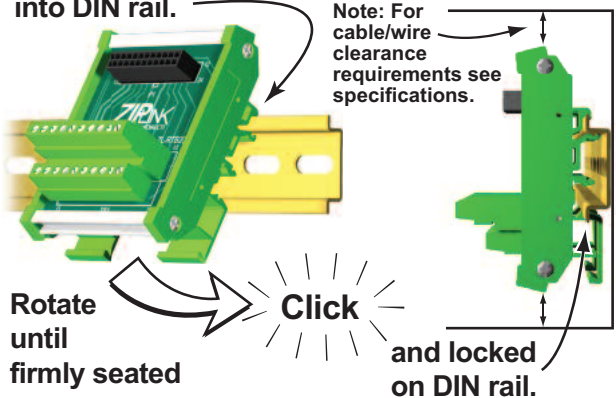

Rotate until firmly seated

To remove ZIPLink module, insert screwdriver between Tab 1 and module.

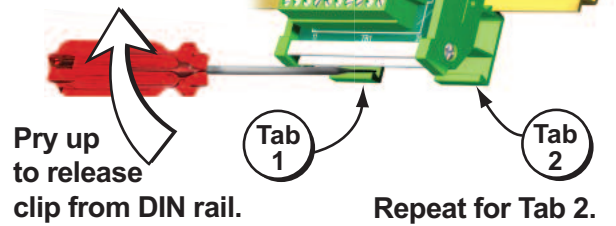

Repeat for Tab 2.

Fuse Replacement Procedure

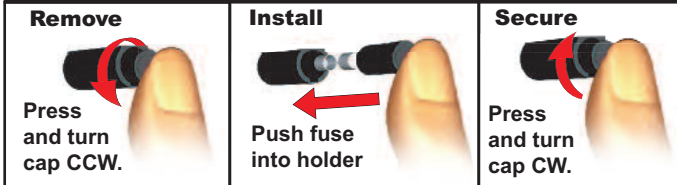

WARNING: To minimize the risk of potential safety problems, you should follow all applicable local and national codes that regulate the installation and operation of your equipment. These codes vary from area to area and it is your responsibility to determine which codes should be followed, and to verify that the equipment, installation, and operation are in compliance with the latest revision of these codes.

Equipment damage or serious injury to personnel can result from the failure to follow all applicable codes and standards. We do not guarantee the products described in this publication are suitable for your particular application, nor do we assume any responsibility for your product design, installation, or operation.

If you have any questions concerning the installation or operation of this equipment, or if you need additional information, please call Technical Support at 770-844-4200.

This publication is based on information that was available at the time it was printed. At AutomationDirect.com® we constantly strive to improve our products and services, so we reserve the right to make changes to the products and/or publications at any time without notice and without any obligation. This publication may also discuss features that may not be available in certain revisions of the product.

Specifications

	32-point fuse connector module
Approvals	File # E200031 UL, cUL, Class 1, Division 2, Groups A, B, C, D Hazardous Locations, CE, EN 61131-2:2007
Operation Voltage**	0-30VDC
Continuous Current Rating	0.3A per circuit
Max Current per Circuit	0.4A
Maximum Current per Module	20A
Number of Circuits	32
Field to Logic Side Isolation	1800VAC applied for 1 second
Insulation Resistance	>10M Ω @ 500VDC
Surrounding Temperature Range	32 to 140°F (0 to 60°C)
Terminal Block Contacts	Copper alloy, tin-lead plated
Wire Range (Rated Cross Section)**	12-24AWG Solid or Stranded Copper Conductor (2.5mm²)
Wire Strip Length	0.24-0.27" (6-7mm)
Screw Torque	4.4 in-lbs (0.5 Nm)
Fuses (Not Installed)	Thirty-two 5x20mm, 250V
Connector Type	3M 34000 Series IDC Connector, strain relief is required to latch to header. Example: Socket 3417-7640, Strain relief 3448-3040
Dimensions (WxHxD)	10.26" x 3.40" x 2.25" (260.5mm x 86.4mm x 57.2mm)
Replacement Fuse	See Edison 5x20mm Glass Fuse section range up to a Max. 0.4 amp fuse.
Cable/Wire Clearance	0.5" (12.7mm) top and bottom
Mounting Restrictions	None

*Connecting cables are for internal wiring only.

**Use Class 2 power supply. Use conductors rated 60°/75°C

HAZARD WARNING

- A. THIS EQUIPMENT IS SUITABLE FOR USE IN CLASS I, DIVISION 2/ZONE 2, GROUPS A, B, C AND D OR NON-HAZARDOUS LOCATIONS ONLY.
- B. **WARNING – EXPLOSION HAZARD** – SUBSTITUTION OF COMPONENTS MAY IMPAIR SUITABILITY FOR CLASS I, DIVISION 2/ZONE 2.
- C. **WARNING – EXPLOSION HAZARD** – DO NOT CONNECT OR DISCONNECT CONNECTORS OR OPERATE SWITCHES WHILE CIRCUIT IS LIVE UNLESS THE AREA IS KNOWN TO BE NON-HAZARDOUS.
- D. ALL MODULES USED WITH ACCESSORIES MUST USE R/C (ECBT2) MATING PLUG FOR ALL APPLICABLE MODELS. ALL MATING PLUGS SHALL HAVE SUITABLE RATINGS FOR DEVICE.