

# CLICK I/O Module Specifications

CO-08TR



## 8-Point Relay Output Module

8-point 6-240 VAC/6-27 VDC relay output module, 8 Form A (SPST) relays, 2 commons, isolated, 1 A/point, removable terminal block included (replacement ADC p/n CO-08TB).

### Wiring Diagram

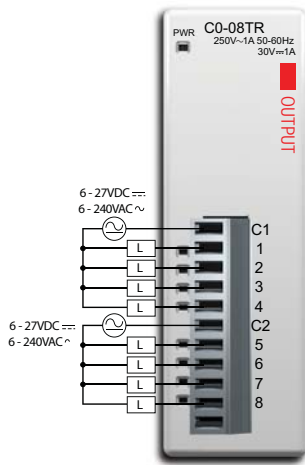

CO-08TR Output Specifications	
<b>Outputs per Module</b>	8
<b>Operating Voltage Range</b>	6-27 VDC / 6-240 VAC
<b>Output Voltage Range</b>	5-30 VDC / 5-264 VAC
<b>Output type</b>	Relay, form A (SPST)
<b>AC Frequency</b>	47-63 Hz
<b>Maximum Current (resistive)</b>	1 A/point, 4 A/common
<b>Minimum Load Current</b>	5 mA @ 5 VDC
<b>Maximum Leakage Current</b>	0.1 mA @ 264 VAC
<b>Maximum Inrush Current</b>	3 A for 10 ms
<b>OFF to ON Response</b>	< 15 ms
<b>ON to OFF Response</b>	< 15 ms
<b>Status Indicators</b>	Logic Side (8 points, red LED) Power Indicator (green LED)
<b>Commons</b>	2 (4 points/common) Isolated
<b>Bus Power Required (24 VDC)</b>	Max. 100 mA (All Outputs On)
<b>Protection Circuit</b>	Not built into the module - Install protection elements such as external fuse
<b>Terminal Block Replacement</b>	ADC p/n CO-8TB
<b>Weight</b>	3.9 oz (110 g)

### Equivalent Output Circuit

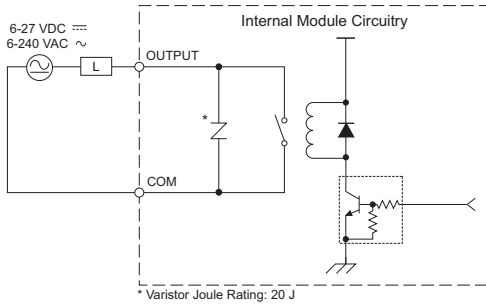

### Typical Relay Life (Operations) at Room Temperature

Voltage & Load Type	Load Current: 1 A
30 VDC Resistive	300,000 cycles
30 VDC Solenoid	50,000 cycles
250 VAC Resistive	500,000 cycles
250 VAC Solenoid	200,000 cycles
ON to OFF = 1 cycle	

### Output Temperature Derating Chart

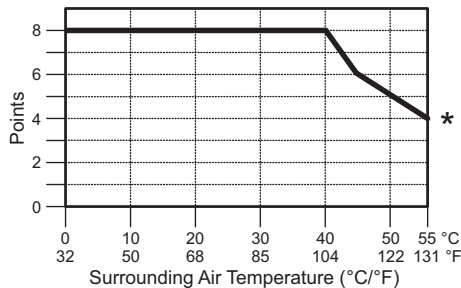

### ZipLink Pre-Wired PLC Connection Cables and Modules



ZL-RTB20 20-pin feed-through connector module



11-pin connector cable  
ZL-C0-CBL11 (0.5 m length)  
ZL-C0-CBL11-1 (1.0 m length)  
ZL-C0-CBL11-2 (2.0 m length)

# Power Budgeting

## Power Budgeting

There are two areas to be considered when determining the power required to operate a CLICK PLC system. The first area is the power required by the CLICK CPU, along with the internal logic side power that the CPU provides to its own I/O and any connected I/O modules that are powered through the CPU's expansion port; plus any device, such as a C-more Micro-Graphic panel, that is powered through one of the CPU's communication ports.

The second area is the power required by all externally connected I/O devices. This should be viewed as the field side power required. The field side power is dependent on the voltage used for a particular input or output device as it relates to the wired I/O point, and the calculated load rating of the connected device.

It is strongly recommended that the power source for the logic side be separate from the power source for the field side to help eliminate possible electrical noise.

Power budgeting requires the calculation of the total current that the 24 VDC power source needs to provide to CLICK's logic side, and also a separate calculation of the total current required for all devices operating from the field side of the PLC system.

See the Power Budgeting Example shown to the right. The table shows current requirements for a CLICK CPU, two I/O modules, and a C-more Micro. Use the total amperage values to select a proper sized power supply.

### Power Budgeting Using the CLICK Programming Software

The following example shows the logic side current consumption as calculated in the CLICK Programming software. Based on the amperage rating of the power supply selected in the first column, your power budget is calculated by subtracting each consecutive module's power consumption from the total available power budget. If you exceed the maximum allowable power consumption the power budget row is highlighted in red.

Power budget row turns red if maximum allowable power consumption is exceeded for the power supply selected.



CLICK 24 VDC Power Supply  
CO-00AC or CO-01AC



Other 24 VDC Power Supply  
Example: PSP24-60S

Current Consumption (mA)		
Part Number	Power Budget 24 VDC (logic side)	External 24 VDC (field side)
<b>Input Modules</b>		
CO-08ND3	30	0
CO-08ND3-1	30	0
CO-16ND3	40	0
CO-08NE3	30	0
CO-16NE3	40	0
CO-08NA	30	0
<b>Output Modules</b>		
CO-08TD1	50	15
CO-08TD2	50	0
CO-16TD1	80	100
CO-16TD2	80	0
CO-08TA	80	0
CO-04TRS	100	0
CO-08TR	100	0
<b>C-more Micro-Graphic Panel (Monochrome models only)</b>		
All p/n	90	0

### Power Budgeting Example

Current Consumption (mA) Example		
Part Number	Power Budget 24 VDC (logic side)	External 24 VDC (field side)
CO-00DD1-D	120	60
CO-16ND3	40	0
CO-16TD1	80	100
C-more Micro	90	0
<b>Total:</b>	<b>330</b>	<b>160*</b>

\* Plus calculated load of connected I/O devices.

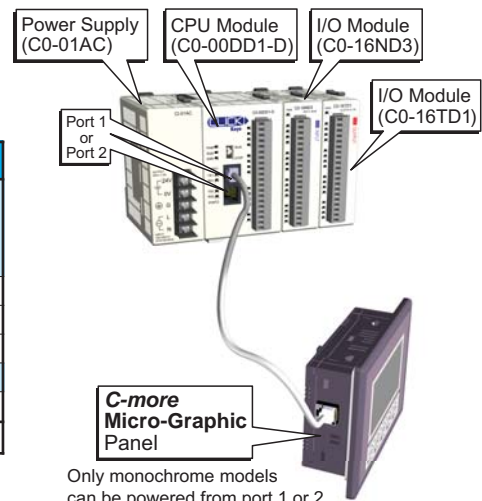

Only monochrome models can be powered from port 1 or 2.

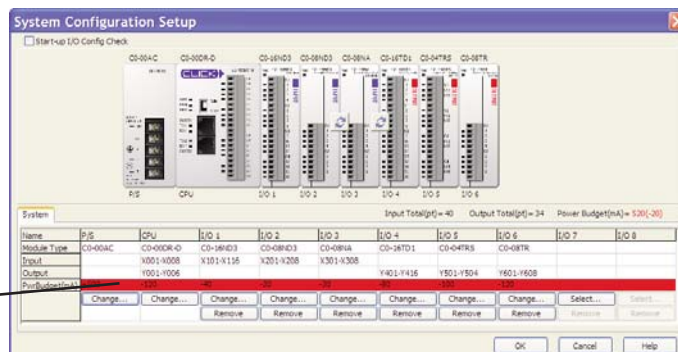

# Choosing the I/O Type

## Analog CPU Modules

The Analog CLICK CPU modules are available with different combinations of DC in, DC sinking, sourcing or relay out, and analog in and out.

They also have an RS-485 port for Modbus and ASCII communications, and the battery backup feature which will retain the data in SRAM for 5 years (battery sold separately; part no. D2-BAT-1).

The table lists the part numbers showing the various I/O type combinations.

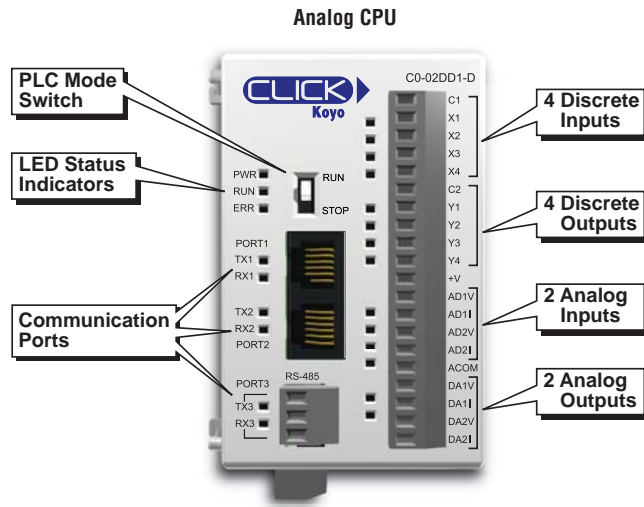

Analog CLICK CPUs					
Part Number	Discrete Input Types	Discrete Output Types	Analog Input Types	Analog Output Types	External Power
<b>C0-02DD1-D</b>	4 DC (sink/source)	4 DC (sink)	2 channel; voltage (0-5 VDC) / current (4-20 mA); selectable separately per channel	2 channel; voltage (0-5 VDC) / current (4-20 mA); selectable separately per channel	24 VDC (required for all CPUs)
<b>C0-02DD2-D</b>		4 DC (source)			
<b>C0-02DR-D</b>		4 relay			

## Discrete I/O Modules

A variety of I/O modules are available for the CLICK PLC system. Up to 8 I/O modules can be connected to a CLICK CPU module to expand the system I/O count and meet the needs of a specific application. Complete I/O module specifications and wiring diagrams can be found later in this section.

## Input Modules

Discrete Input I/O Modules					
Part Number	I/O Type	I/O Number	I/O Commons	Sink or Source	Voltage Ratings
<b>C0-08ND3</b>	DC	8	2	Sink or Source	12-24 VDC
<b>C0-08ND3-1</b>	DC	8	2	Sink or Source	3.3-5 VDC
<b>C0-16ND3</b>	DC	16	4	Sink or Source	24 VDC
<b>C0-08NE3</b>	AC/DC	8	2	Sink or Source	24 VAC/VDC
<b>C0-16NE3</b>	AC/DC	16	4	Sink or Source	24 VAC/VDC
<b>C0-08NA</b>	AC	8	2	N/A	100-120 VAC



C0-08ND3



C0-08ND3-1

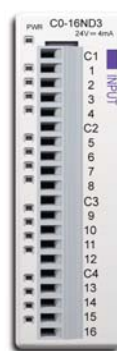

C0-16ND3



C0-08NE3



C0-16NE3



C0-08NA

# Choosing the I/O Type / Specifications

## Discrete I/O Modules (continued)

## Output Modules

Discrete Output I/O Modules					
Part Number	I/O Type	I/O Number	I/O Commons	Sink or Source	Voltage/Current Ratings
<b>CO-08TD1</b>	DC	8	2	Sink	3.3-27 VDC, 0.3 A
<b>CO-08TD2</b>	DC	8	1	Source	12-24 VDC, 0.3 A
<b>CO-16TD1</b>	DC	16	2	Sink	5-27 VDC, 0.1 A
<b>CO-16TD2</b>	DC	16	2	Source	12-24 VDC, 0.1 A
<b>CO-08TA</b>	AC	8	2	N/A	17-240 VAC, 0.3 A
<b>CO-04TRS</b>	Relay	4	4	N/A	6-27 VDC, 7 A 6-240 VAC, 7 A
<b>CO-08TR</b>	Relay	8	2	N/A	6-27 VDC, 1 A 6-240 VAC, 1 A

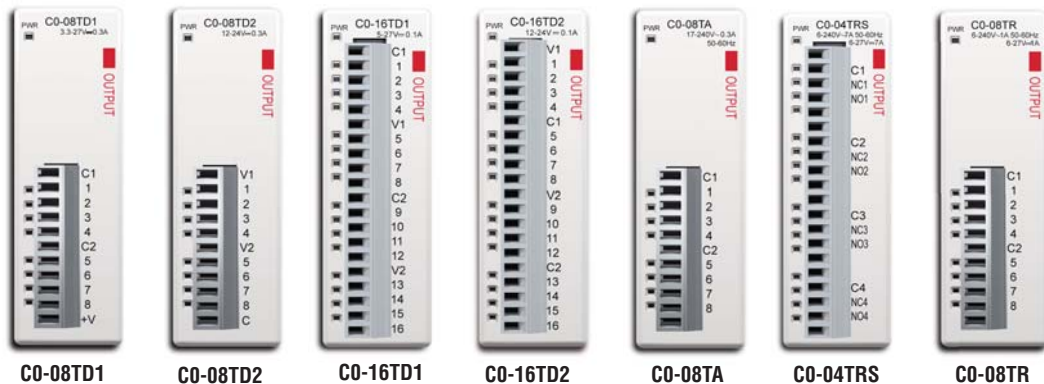

## General Specifications For All CLICK PLC Products

These general specifications apply to all CLICK CPUs, optional I/O modules, and optional power supply products. Please refer to the appropriate I/O temperature derating charts under both the CPU and I/O module specifications to determine best operating conditions based on the ambient temperature of your particular application.

General Specifications	
<b>Power Input Voltage Range</b>	20-28 VDC
<b>Maximum Power Consumption</b>	5 W (No 5 V use from communication port)
<b>Maximum Inrush Current</b>	30 A (less than 1ms)
<b>Acceptable External Power Drop</b>	Max 10 ms
<b>Operating Temperature</b>	32°F to 131°F (0°C to 55°C), IEC 60068-2-14 (Test Nb, Thermal Shock)
<b>Storage Temperature</b>	-4°F to 158°F (-20°C to 70°C) IEC 60068-2-1 (Test Ab, Cold) IEC 60068-2-2 (Test Bb, Dry Heat) IEC 60068-2-14 (Test Na, Thermal Shock)
<b>Ambient Humidity</b>	30% to 95% relative humidity (non-condensing)
<b>Environmental Air</b>	No corrosive gases. Environmental pollution level is 2 (UL840)
<b>Vibration</b>	MIL STD 810C, Method 514.2, EC60068-2-6 JIS C60068-2-6 (Sine wave vibration test)
<b>Shock</b>	MIL STD 810C, Method 516.2, IEC60068-2-27, JIS C60068-2-27
<b>Noise Immunity</b>	Comply with NEMA ICS3-304, Impulse noise 1μs, 1000V EN61000-4-2 (ESD), EN61000-4-3 (RFI), EN61000-4-4 (FTB) EN61000-4-5 (Surge), EN61000-4-6 (Conducted) EN61000-4-8 (Power frequency magnetic field immunity) RFI: No interference measured at 150 and 450 MHz (5w/15cm)
<b>Emissions</b>	EN55011:1998 Class A
<b>Agency Approvals</b>	UL508 (File No. E157382, E316037); CE (EN61131-2)
<b>Other</b>	RoHS

# ZIPLINK™ Wiring Solutions

Automation Direct

## Wiring Solutions using the ZIPLink Wiring System

ZIPLinks eliminate the normally tedious process of wiring between devices by utilizing prewired cables and DIN rail mount connector modules. It's as simple as plugging in a cable connector at either end or terminating wires at only one end. Prewired cables keep installation clean and efficient, using half the space at a fraction of the cost of standard terminal blocks. There are several wiring solutions available when using the ZIPLink System ranging from

PLC I/O-to-ZIPLink Connector Modules that are ready for field termination, options for connecting to third party devices, GS, DuraPulse and SureServo Drives, and specialty relay, transorb and communications modules. Pre-printed I/O-specific adhesive label strips for quick marking of ZIPLink modules are provided with ZIPLink cables. See the following solutions to help determine the best ZIPLink system for your application.

### Solution 1: DirectLOGIC, CLICK and Productivity3000 I/O Modules to ZIPLink Connector Modules

When looking for quick and easy I/O-to-field termination, a ZIPLink connector module used in conjunction with a prewired ZIPLink cable, consisting of an I/O terminal block at one end and a multi-pin connector at the other end, is the best solution.



Using the PLC I/O Modules to ZIPLink Connector Modules selector tables located in this section,

1. Locate your I/O module/PLC.
2. Select a ZIPLink Module.
3. Select a corresponding ZIPLink Cable.

### Solution 2: DirectLOGIC, CLICK and Productivity3000 I/O Modules to 3rd Party Devices

When wanting to connect I/O to another device within close proximity of the I/O modules, no extra terminal blocks are necessary when using the ZIPLink Pigtail Cables. ZIPLink Pigtail Cables are prewired to an I/O terminal block with color-coded pigtail with soldered-tip wires on the other end.



Using the I/O Modules to 3rd Party Devices selector tables located in the ZIPLink section,

1. Locate your PLC I/O module.
2. Select a ZIPLink Pigtail Cable that is compatible with your 3rd party device.

### Solution 3: GS Series and DuraPulse Drives Communication Cables

Need to communicate via Modbus RTU to a drive or a network of drives?

ZIPLink cables are available in a wide range of configurations for connecting to PLCs and SureServo, SureStep, Stellar Soft Starter and AC drives. Add a ZIPLink communications module to quickly and easily set up a multi-device network.

Using the Drives Communication selector tables located in the ZIPLink section,

1. Locate your Drive and type of communications.
2. Select a ZIPLink cable and other associated hardware.



## Solution 4: Serial Communications Cables

ZIPLink offers communications cables for use with *Direct*LOGIC, CLICK, and Productivity3000 CPUs, that can also be used with other communications devices. Connections include a 6-pin RJ12 or 9-pin, 15-pin and 25-pin D-sub connectors which can be used in conjunction with the RJ12 or D-Sub Feedthrough modules.

Using the **Serial Communications Cables** selector table located in the **ZIPLink** section,

1. Locate your connector type
2. Select a cable.



## Solution 5: Specialty ZIPLink Modules

For additional application solutions, **ZIPLink** modules are available in a variety of configurations including stand-alone relays, 24VDC and 120VAC transorb modules, D-sub and RJ12 feedthrough modules, communication port adapter and distribution modules, and *SureServo* 50-pin I/O interface connection.

Using the **ZIPLink Specialty Modules** selector table located in the **ZIPLink** section,

1. Locate the type of application.
2. Select a ZIPLink module.



## Solution 6: ZIPLink Connector Modules to 3rd Party Devices

If you need a way to connect your device to terminal blocks without all that wiring time, then our pigtail cables with color-coded soldered-tip wires are a good solution. Used in conjunction with any compatible **ZIPLink** Connector Modules, a pigtail cable keeps wiring clean and easy and reduces troubleshooting time.

Using the **Universal Connector Modules and Pigtail Cables** table located in the **ZIPLink** section,

1. Select module type.
2. Select the number of pins.
3. Select cable.



# PLC I/O Modules to ZIPLink Connector Modules - CLICK

CLICK PLC Input Module ZIPLink Selector				
PLC		ZIPLink		
Input Module	# of Terms	Component	Module Part No.	Cable Part No.
CO-08ND3	11	Feedthrough	ZL-RTB20	ZL-CO-CBL11*
CO-08ND3-1	11	Feedthrough	ZL-RTB20	ZL-CO-CBL11*
CO-08NE3	11	Feedthrough	ZL-RTB20	ZL-CO-CBL11*
CO-08NA	11	Feedthrough	ZL-RTB20	ZL-CO-CBL11*
CO-16ND3	20	Feedthrough	ZL-RTB20	ZL-CO-CBL20*
		Sensor	ZL-LTB16-24	ZL-CO-CBL20*
CO-16NE3	20	Feedthrough	ZL-RTB20	ZL-CO-CBL20*
		Sensor	ZL-LTB16-24	ZL-CO-CBL20*

CLICK PLC Combo In/Out Module ZIPLink Selector				
PLC		ZIPLink		
Combo Module	# of Terms	Component	Module Part No.	Cable Part No.
CO-00DD1-D	20	Feedthrough	ZL-RTB20	ZL-CO-CBL20*
CO-00DD2-D	20	Feedthrough	ZL-RTB20	ZL-CO-CBL20*
CO-00DR-D	20	Feedthrough	ZL-RTB20	ZL-CO-CBL20*
CO-00AR-D	20	Feedthrough	ZL-RTB20	ZL-CO-CBL20*
CO-01DD1-D	20	Feedthrough	ZL-RTB20	ZL-CO-CBL20*
CO-01DD2-D	20	Feedthrough	ZL-RTB20	ZL-CO-CBL20*
CO-01DR-D	20	Feedthrough	ZL-RTB20	ZL-CO-CBL20*
CO-01AR-D	20	Feedthrough	ZL-RTB20	ZL-CO-CBL20*

CLICK PLC Output Module ZIPLink Selector				
PLC		ZIPLink		
Output Module	# of Terms	Component	Module Part No.	Cable Part No.
CO-08TD1	11	Feedthrough	ZL-RTB20	ZL-CO-CBL11*
CO-08TD2	11	Feedthrough	ZL-RTB20	ZL-CO-CBL11*
CO-08TR	11	Feedthrough	ZL-RTB20	ZL-CO-CBL11*
CO-08TA	11	Feedthrough	ZL-RTB20	ZL-CO-CBL11*
CO-16TD1	20	Feedthrough	ZL-RTB20	ZL-CO-CBL20*
		Fuse	ZL-RFU20 <sup>2</sup>	ZL-CO-CBL20*
		Relay (sinking)	ZL-RRL16-24-1	ZL-CO-CBL20*
CO-16TD2	20	Feedthrough	ZL-RTB20	ZL-CO-CBL20*
		Fuse	ZL-RFU20 <sup>2</sup>	ZL-CO-CBL20*
		Relay (sourcing)	ZL-RRL16-24-2	ZL-CO-CBL20*
CO-04TRS <sup>1</sup>	20	Feedthrough	ZL-RTB20	ZL-CO-CBL20*

\* Select the cable length by replacing the \* with: Blank = 0.5m, -1 = 1.0m, or -2 = 2.0m.

<sup>1</sup> Note: The CO-04TRS relay output is derated not to exceed 2A per point max. when used with the ZIPLink wiring system.

<sup>2</sup> Note: Fuses (5 x 20 mm) are not included. See Edison Electronic Fuse section for (5 x 20 mm) fuse. S500 and GMA electronic circuit protection for fast-acting maximum protection. S506 and GMC electronic circuit protection for time-delay performance. Ideal for inductive circuits. To ensure proper operation, do not exceed the voltage and current rating of ZIPLink module. ZL-RFU20 = 2A per circuit; ZL-RFU40 = 400 mA per circuit.



NOTE: ZIPLINK CONNECTOR MODULES AND ZIPLINK CABLES SPECIFICATIONS ARE IN THE ZIPLINK CATALOG SECTION.



Field I/O

Software

C-more &amp; other HMI

Drives

Soft Starters

Motors &amp; Gearbox

Steppers/ Servos

Motor Controls

Proximity Sensors

Photo Sensors

Limit Switches

Encoders

Current Sensors

Pressure Sensors

Temperature Sensors

Pushbuttons/ Lights

Process

Relays/ Timers

Comm.

Terminal Blocks &amp; Wiring

Power

Circuit Protection

Enclosures

Tools

Pneumatics

Safety

Appendix

Product Index

Part # Index