

C-more Micro

It's a touch panel... at a text panel price

Do more with C-more Micro-Graphic!

C-more Micro-Graphic panels have become one of the most popular and most reliable value packed operator interfaces in the industrial market. After all, the low prices allow customers with tight budgets to take advantage of graphic control panel features that are most often found in more expensive touch screen products. The C-more Micro-Graphic selection continues to expand as we now offer 3-inch, 4-inch, and 6-inch panel sizes, in both monochrome and color models. With the addition of the larger 6-inch sizes, you can display even more text, graphics, or bitmaps to effectively communicate and display data to the operator. Touch and non-touch screen models are available in the 3-inch models.

Both TFT Color and STN Monochrome panels are now available. The 3-inch and 6-inch STN monochrome versions each offer five selectable background colors that allow you to use color to convey meaning. Several options, including plug-and-play keypad bezels, are available for both the 3-inch and 6-inch models. The 4-inch and 6-inch TFT full color versions offer up to 32,767 colors for more vibrant and colorful project screens.

Prices
Starting at
\$161

4" TFT model
Starting at
\$356



C-more Micro Panel Selection Guide

Feature	3-inch STN Monochrome Models	6-inch STN Monochrome Models	6-inch TFT Color Models	4-inch TFT Color Models
Display Resolution & Type	128 x 64, touch or non-touch	320 x 240, touch	320 x 240, touch	320 x 240, touch
Ports	1 serial (RJ12) and Optional DSUB15	2 serial (RJ12 and DSUB15)	1 USB (Port 1: USB Type B) 1 Serial (Port 2: DSUB15)	1 USB (Port 1: USB Type B) 1 Serial (Port 2: DSUB15)
User Project Memory	768KB	1,792KB	3.2MB	3.2MB
Portrait Mode	NO	YES	YES	YES
Colors	Monochrome; backlight can be configured per screen and/or per alarm as: red, green, amber, lime, or yellow (standard); or red, white or three shades of pink (high-contrast)	Monochrome; backlight can be configured per screen and/or per alarm as: red, green, amber, lime, or yellow (standard); or red, white or three shades of pink (high-contrast)	32,768 colors	32,768 colors

FREE Configuration Software!

C-more Micro-Graphic Programming Software is based on its powerful sibling, the **C-more** Touch Panel. It offers high end features designed to reduce your configuration time. Simply drag and drop the objects from the Object list (right side of screen) on to the screen construction area. Then configure your PLC tags

and assign them to the objects. Use the built-in simulator to review your work on your PC before ever downloading your project! The time saving benefits of the **C-more** Micro configuration software could easily pay for the panel. **Check out www.C-moreMicro.com for a demo.**

Built-in project simulator

- **Runs your project on your PC**
- **Test all of your screens before downloading**
- **Time savings pays for the panel!**

Built-in user object/screen libraries

Save time by re-using your custom objects and screens.

C-more Micro Programming Software

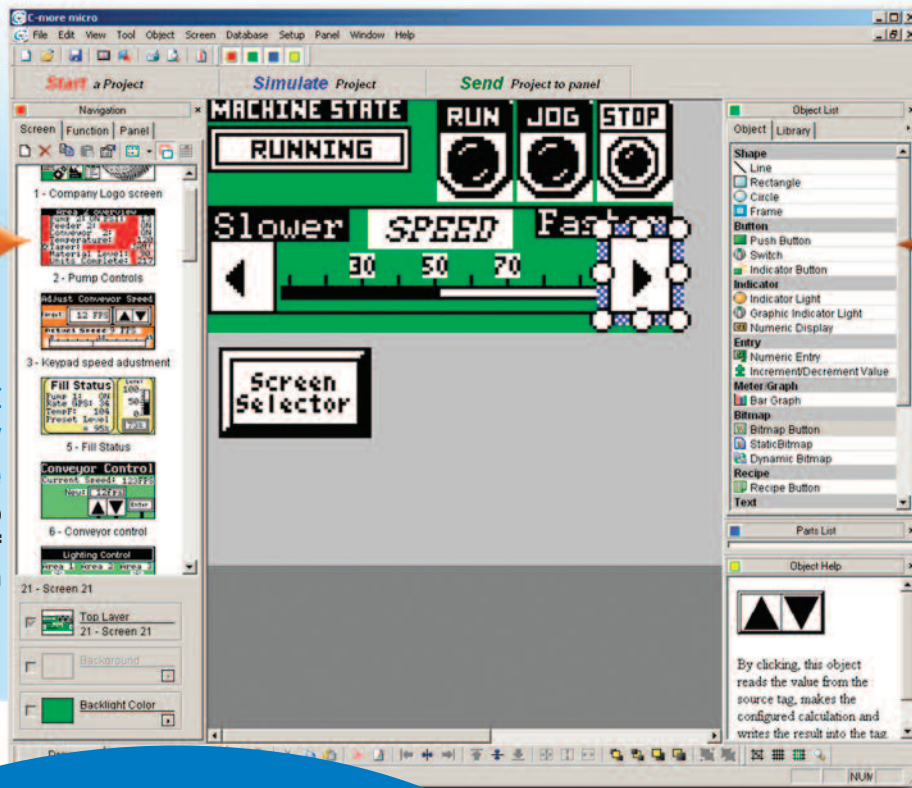

Thumbnail project preview pane
Helps keep track of multi-screen projects.

Scrolling object selection window
Lets you find the object you want fast. Just drag and drop it on the screen.

Download the Software!

C-more Micro-Graphic Programming Software can be downloaded at no charge from the **AutomationDirect** web site, or a CD version may be purchased for \$25 by ordering p/n EA-MG-PGMSW. The software requires a USB port on your PC to connect to the **C-more** Micro-Graphic panel. Help files are included in the software. *This software can only be used to program the C-more Micro-Graphic panels, not the C-more 6" through 15" touch panels.*

Scrolling help window

Gives you helpful information on each object

Learn more! Go to:

www.C-moreMicro.automationdirect.com

for detailed specifications, a virtual tour of the product, programming examples, newest communication drivers...







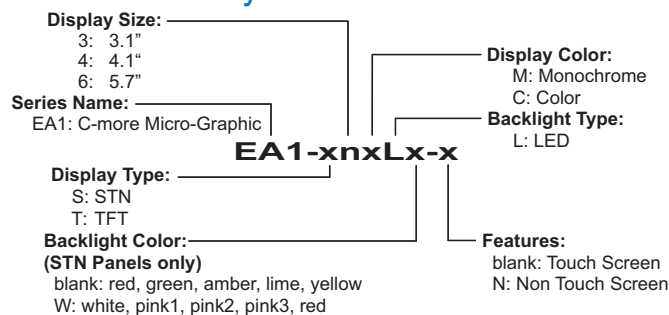

C-more Micro-Graphic Panels Selection Guide

C-more Micro-Graphic Panels			
Part Number		Description	Price
EA1-S3ML		3.1-inch C-more Micro-Graphic Touch Panel with green and red LED backlights. Supports 5 selectable backlight colors (Green, Red, Amber, Yellow and Lime). STN LCD monochrome, 128 x 64 dot display. Has 5 user-defined function keys with LED indicators. Power is supplied to the panel through the serial communication port connection when used with Direct LOGIC PLCs having an RJ12 communication port. EA-MG-SP1 (power supply with serial option module) required when connecting to third party PLCs. NEMA 4/4X, IP65 (when mounted correctly; for indoor use only).	<--->
EA1-S3ML-N	Non-Touch 	3.1-inch C-more Micro-Graphic Non-Touch Panel with green and red LED backlights. Supports 5 selectable backlight colors (Green, Red, Amber, Yellow and Lime). STN LCD monochrome, 128 x 64 dot display. Has 5 user-defined function keys with LED indicators. Power is supplied to the panel through the serial communication port connection when used with Direct LOGIC PLCs having an RJ12 communication port. EA-MG-SP1 (power supply with serial option module) required when connecting to third party PLCs. NEMA 4/4X, IP65 (when mounted correctly; for indoor use only).	<--->
EA1-S3MLW		3.1-inch C-more Micro-Graphic Touch Panel with High Contrast white and red LED backlights. Supports 5 selectable backlight colors (White, Pink1, Pink2, Pink3 and Red). STN LCD monochrome, 128 x 64 dot display. Has 5 user-defined function keys with LED indicators. Power is supplied to the panel through the serial communication port connection when used with Direct LOGIC PLCs having an RJ12 communication port. EA-MG-SP1 (power supply with serial option module) required when connecting to third party PLCs. NEMA 4/4X, IP65 (when mounted correctly; for indoor use only).	<--->
EA1-S3MLW-N	Non-Touch 	3.1-inch C-more Micro-Graphic Non-Touch Panel with High Contrast white and red LED backlights. Supports 5 selectable backlight colors (White, Pink1, Pink2, Pink3 and Red). STN LCD monochrome, 128 x 64 dot display. Has 5 user-defined function keys with LED indicators. Power is supplied to the panel through the serial communication port connection when used with Direct LOGIC PLCs having an RJ12 communication port. EA-MG-SP1 (power supply with serial option module) required when connecting to third party PLCs. NEMA 4/4X, IP65 (when mounted correctly; for indoor use only).	<--->
EA1-T4CL		4-inch C-more Micro-Graphic Touch Panel with TFT Color LCD, 320 x 240 dot, 32,768 color display with LED backlight. 5 user-defined function keys with LED indicators. Two built-in ports (USB Type-B port and 15-pin D-sub RS-232/422/485 port). Display supports Portrait and Landscape modes. NEMA 4/4X, IP65 (when mounted correctly; for indoor use only).	<--->
EA1-S6ML		5.7-inch C-more Micro-Graphic Touch Panel with STN LCD monochrome, 320x240 dot display. The panel has red and green LED backlights. Supports 5 selectable backlight colors (Red, Green, Amber, Lime, and Yellow). Includes 5 user-defined function keys with LED indicators. 2 built in serial Ports (RS-232 RJ12 port and 15 pin D-sub RS-232/422/485). NEMA 4/4X, IP65 (when mounted correctly; for indoor use only).	<--->
EA1-S6MLW		5.7-inch C-more Micro-Graphic Touch Panel with STN LCD monochrome, 320x240 dot display. The panel has white and red LED backlights. Supports 5 selectable backlight colors (White, Pink1, Pink2, Pink3, and Red). Includes 5 user-defined function keys with LED indicators. 2 built in serial Ports (RS-232 RJ12 port and 15 pin D-sub RS-232/422/485). NEMA 4/4X, IP65 (when mounted correctly; for indoor use only).	<--->
EA1-T6CL		5.7-inch C-more Micro-Graphic Touch Panel with TFT Color LCD, 320 x 240 dot, 32,768 color display with LED backlight. 5 user-defined function keys with LED indicators. Two built-in ports (USB Type-B port and 15-pin D-sub RS-232/422/485 port). Display supports Portrait and Landscape modes. NEMA 4/4X, IP65 (when mounted correctly; for indoor use only).	<--->

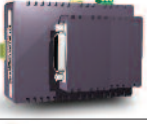
C-more Micro-Graphic Panel Part No. Key:



C-more Micro-Graphic Panels Selection Guide

C-more Micro-Graphic Panel Accessories			
Part Number		Description	Price
EA-MG-BZ1		8-button keypad bezel for C-more 3" Micro-Graphic panels, with 4 arrow adjust keys, and ESCAPE, MENU, CLEAR and ENTER buttons. Helps to reduce screen wear in heavy-duty applications where operators can use the keypad. Designed for easy drop-in of the Micro-Graphic panels.	<--->
EA-MG-BZ2		20-button keypad bezel with numeric keypad for C-more 3" Micro-Graphic panels, with 4 arrow adjust keys, and ESCAPE, MENU, CLEAR and ENTER buttons. Helps to reduce screen wear in heavy-duty applications where operators can use the keypad to enter numeric data. Designed for easy drop-in of the Micro-Graphic panels.	<--->
EA-MG-P1		Optional DC Power Adapter for C-more 3" Micro-Graphic panels. Required when using third party PLCs, or when using 24 VDC power instead of the 5 VDC supplied from the RJ12 connector of a Productivity Series, CLICK or Direct LOGIC PLC.	<--->
EA-MG-SP1		Optional Serial Port with DC Power Adapter for C-more 3" Micro-Graphic panels. Serial port is a D-Sub 15-pin RS-232/RS-422/485 connector. Required when using RS422, RS485 or third party PLCs.	<--->
EA-MG-COV-CL		Optional clear screen overlay used to protect C-more 3" Micro-Graphic displays from minor scratches and wear. Package contains 5 clear screen overlays.	<--->
EA-4-COV2		Optional clear screen overlay used to protect C-more 4" Micro-Graphic displays from minor scratches and wear. Package contains 3 clear screen overlays.	<--->
EA-MG6-BZ2		For Landscape (Horizontal) Mounted Panels. 20-button keypad bezel with numeric keypad for C-more 6" Micro-Graphic panels, 4 arrow adjust keys, and ESCAPE, MENU, CLEAR and ENTER buttons. Helps to reduce screen wear in heavy-duty applications where operators can use the keypad to enter numeric data. Designed for easy drop-in of the Micro-Graphic panels.	<--->
EA-MG6-BZ2P		For Portrait (Vertical) Mounted Panels. 21-button keypad bezel with numeric keypad for C-more 6" Micro-Graphic panels, 4 arrow adjust keys, and ESCAPE, MENU, CLEAR and (2) ENTER buttons. Helps to reduce screen wear in heavy-duty applications where operators can use the keypad to enter numeric data. Designed for easy drop-in of the Micro-Graphic panels.	<--->
EA-6-COV2		Optional clear screen overlay used to protect C-more 6" Micro-Graphic displays from minor scratches and wear. Package contains 3 clear screen overlays.	<--->

C-more 3" Micro-Graphic Specifications

Specification	Model	3" STN Micro-Graphic Panel Touch Screen	3" STN Micro-Graphic Panel Non-Touch Screen
Part Number		EA1-S3ML, EA1-S3MLW	EA1-S3ML-N, EA1-S3MLW-N
Description		128 x 64 dots LCD display, five user defined keypad function buttons, and five user defined LED's	
Display			
• Type		3.1" STN monochrome LCD, graphical characters	
• Resolution		128 (W) x 64 (H) dots	
• Color		2 colors (normal / inverse)	
• Viewing Area Size		2.789" (W) x 1.385" (H) [70.8 mm x 35.2 mm]	
• Active Area Size		2.670" (W) x 1.259" (H) [67.8 mm x 32.0 mm]	
• Contrast		Adjusted from the panel's built-in configuration setup menu	
• Viewing Angle		3, 9 o'clock axis → 45 degrees 6 o'clock axis → 45 degrees 12 o'clock axis → 30 degrees	
Backlight			
• Type		LED	
• Color		5 user defined colors: EA1-S3ML, EA1-S3ML-N - Red, Green, Amber, Lime, and Yellow EA1-S3MLW, EA1-S3MLW-N - White, Pink1, Pink2, Pink3 and Red	
• User Replaceable		No	
Touch Screen			
• Type		Analog touch panel	N/A
• Operation		51 gram force [0.5 N] maximum	N/A
• Life		Minimum of 1,000,000 cycles	N/A
Features			
• User Memory		768 KB	
• Number of Screens		Up to 999 – limited by project memory usage	
• Beep (Internal)		Yes	
• Keypad Function Buttons		Five user defined function key buttons with the ability to customize the label. Minimum of 500,000 cycles	
• Keypad Function Button LEDs		Each function key button includes a red LED that can be user programmed.	
• Serial Communications		Built-in RJ12 serial communications port (RS-232). Optional serial communications port (RS-232, RS-485/422) when using the optional EA-MG-SP1 Serial Port with DC Power Adapter.	
• Expansion Connection		Yes – used with optional Keypad Bezels, EA-MG-BZ1 & BZ2, and EA-MG-P1 DC Power Adapter, and EA-MG-SP1 Serial Port with DC Power Adapter.	
Screen Objects			
• Functional Devices		Push Button, Switch, Indicator Button, Indicator Light, Graphic Indicator Light, Numeric Display, Numeric Entry, Inc/Dec Value, Bar Graph, Bitmap Button, Static Bitmap, Dynamic Bitmap, Recipe Button, Static Text, Lookup Text, Dynamic Text, Scroll Text, Screen Change Push Button, Screen Selector, Adjust Contrast, Function, Key Configuration Object, Realtime Graph, Line Graph, Analog Meter	
• Static Shapes		Lines, Rectangles, Circles and Frames	
• Displayable Fonts		Fixed fonts: 4x6, 6x6, 6x6B, 6x8, 8x16, 8x32, 8x64, 16x16, 16x32, 16x64, 32x16, 32x32, 32x64, and Windows fonts	
C-more 3" Micro-Graphic panel specifications continued on next page.			



NOTE: Photo includes EA-MG-BZ2

C-more 3" Micro-Graphic Specifications

Specification	Model	3" STN Micro-Graphic Panel Touch Screen	3" STN Micro-Graphic Panel Non-Touch Screen
Part Number		EA1-S3ML, EA1-S3MLW	EA1-S3ML-N, EA1-S3MLW-N
Electrical			
• Input Voltage Range		5.0 VDC (4.75 – 5.25 VDC)	
• Input Power		Supplied through the panel's RJ12 serial communications port connection when used with any AutomationDirect PLC having an RJ12 communication port. Can also be supplied from an external 12-24 VDC power source when using the optional EA-MG-P1 DC Power Adapter, or the optional EA-MG-SP1 Serial Port with DC Power Adapter	
• Power Consumption		1.05W (220mA @ 4.75 VDC)	
• Recommended Fuse		Type AGC fast acting glass fuse, 250 mA, 250 VAC, ADC p/n AGC-25 No fuse required when directly connected to a PLC or PC with recommended cable.	
• Maximum Inrush Current		1 A for 500 μ s	
• Acceptable External Power Drop Duration		Maximum 1 ms	
Environmental			
• Operating Temperature		0 to 50 °C (32 to 122 °F) Maximum surrounding air temperature rating: 50 °C	
• Storage Temperature		-20 to +60 °C (-4 to +140 °F)	
• Humidity		5-95% RH (non-condensing)	
• Environmental Air		For use in Pollution Degree 2 Environment	
• Vibration		IEC60068-2-6 (Test Fc), 5-9 Hz: 3.5 mm amplitude, 9-150 Hz: 1.0G, sweeping, at a rate of 1 octave/min. (\pm 10%), 10 sweep cycles per axis on each of 3 mutually perpendicular axes	
• Shock		IEC60068-2-27 (Test Ea), 15 G peak, 11 ms duration, three shocks in each direction per axis, on 3 mutually perpendicular axes (total of 18 shocks)	
• Noise Immunity		NEMA ICS3-304 RFI, (145 MHz, 440 MHz 10 W @ 10 cm) Impulse 1000 V @ 1 μ s pulse	
• Enclosure		For use on a flat surface of Type 1, 4X enclosure (Indoor use only)	
• Agency Approvals		CE (EN61131-2), UL508, CUL Canadian C22.2 No. 142-M95, UL File E157382, CSA File 234884	
Physical			
• Dimensions		4.488" (W) x 3.228" (H) x 1.593" (D) [114.0 mm x 82.0 mm x 40.5 mm]	
• Enclosure Mounting Thickness Range		0.04" – 0.2" [1 – 5 mm]	
• Mounting Clip Screw Torque Range		21 – 28 oz-in [0.15 – 0.2 Nm]	
• Depth from bezel rear with options Module		2.295" [58.3 mm]	
• Weight		5.82 oz. (165 g)	



NOTE: The environmental specifications for the panels shown above are also applicable for the C-more Micro-Graphic Accessories shown later in this section of the catalog.

Supported Protocols / Drivers	
Serial - Panel port1 or port2*	Serial - Panel port2 only *
AutomationDirect Productivity Series	Allen-Bradley DF1 Full Duplex
AutomationDirect CLICK	Allen-Bradley DF1 Half Duplex
AutomationDirect K-sequence	Allen-Bradley PLC5 DF1
AutomationDirect DirectNET	Allen-Bradley DH485
AutomationDirect Modbus	GE SNPX (90/30, 90/70, Micro 90, VersaMax Micro)
Modicon Modbus RTU	Mitsubishi FX
Entivity Modbus RTU	Mitsubishi Q & QnA
GS Drives	Omron Host Link (C200 Adapter, C500)
SOLO Temperature Controller	Omron FINS Serial (CJ1, CS1)
	Siemens PPI (S7-200 CPU)

***Note: Serial port 2 requires the use of EA-MG-SP1 adapter for C-more 3" Micro-Graphic panels**



For a list of supported protocols and cabling options refer to the 3" C-more Micro-Graphic Protocols and cabling chart starting on page 11-24.

C-more 4" Micro-Graphic Specifications

Specifications		
Description:	320 x 240 dots LCD display (Landscape Mode), Five user defined keypad function buttons, and five user defined LED's	
Display:		
• Type	4.1" TFT Color LCD, graphical characters	
• Resolution	320 (W) x 240 (H) dots (Landscape Mode) 240 (W) x 320 (H) dots (Portrait Mode)	
• Color	32768 colors	
• Display Brightness (Reference)	USB Bus Power (Programming)	High Power Mode
	180 nits (typ)	360 nits (typ)
• Viewing Area Size	3.357" (W) x 2.54" (H) [85.26 mm x 64.62 mm]	
• Active Area Size	3.250" (W) x 2.438" (H) [82.56 mm x 61.92 mm]	
• Brightness	Adjusted from the panel's built-in configuration setup menu	
• Viewing Angle (Landscape Mode)	3 o'clock axis → 35 degrees 6 o'clock axis → 50 degrees 12 o'clock axis → 20 degrees	
Backlight:		
• Type	LED	
• Color	White	
• User Replaceable	No	
Touch Screen:		
• Type	Analog touch panel	
• Operation	82 gram force [0.8 N] maximum	
• Life	Minimum of 1,000,000 cycles	
Features:		
• User Memory	3276 kBytes	
• Number of Screens	Up to 999 – limited by project memory usage	
• Beep (Internal)	Yes	
• Keypad Function Buttons	Five user defined function key buttons with the ability to custom label with an overlay. Minimum of 500,000 cycles	
• Keypad Function Button LEDs	Each function key button includes a red LED that can be user programmed.	
• Programming Port	USB Type B	
• Serial Communications	15-pin D-sub serial communications port (RS-232, RS-485 / 422).	
Screen Objects:		
• Functional Devices	Push Button, Switch, Indicator Button, Indicator Light, Graphic Indicator Light, Numeric Display, Numeric Entry, Inc/Dec Value, Bar Graph, Bitmap Button, Static Bitmap, Dynamic Bitmap, Recipe Button, Static Text, Lookup Text, Dynamic Text, Screen Change Push Button, Screen Selector, Adjust Contrast, Function, Key Configuration Object, Real Time Graphics Line Graph, Analog Meter.	
• Static Shapes	Lines, Rectangles, Circles and Frames	
• Displayable Fonts	Fixed fonts: 4x6, 6x6, 6x6B, 6x8, 8x16, 8x32, 8x64, 16x16, 16x32, 16x64, 32x16, 32x32, 32x64, and Windows fonts	
C-more 4" Micro-Graphic panel specifications continued on next page.		

C-more 4" Micro-Graphic Specifications

Specifications (cont'd)

Electrical:

	USB Bus Power (Programming)	High Power Mode
• Input Voltage Range	5.0 VDC (4.75 – 5.25 VDC)	12/24 VDC (10.2 – 26.4 VDC)
• Input Power	Supplied from a PC USB.	Supplied from an external 12-24 VDC power source
• Power Consumption	2W	4.5 W
• Recommended Fuse	No fuse required when directly connected to a PC with recommended cable.	Type AGC fast acting glass fuse, 750 mA, 250 VAC, ADC p/n AGC-75
• Maximum Inrush Current	4.5 A for 800 μ s	8 A for 800 μ s
• Acceptable External Power Drop Duration	Maximum 1 ms	

Environmental:

• Operating Temperature	0 to 50 °C (32 to 122 °F) Maximum surrounding air temperature rating: 50 °C
• Storage Temperature	-20 to +60 °C (-4 to +140 °F)
• Humidity	5–95% RH (non-condensing)
• Environmental Air	For use in Pollution Degree 2 environment
• Vibration	IEC60068-2-6 (Test Fc), 5-9 Hz: 3.5 mm amplitude, 9-150 Hz: 1.0G, sweeping, at a rate of 1 octave/min. (\pm 10%), 10 sweep cycles per axis on each of 3 mutually perpendicular axes
• Shock	IEC60068-2-27 (Test Ea), 15 G peak, 11 ms duration, three shocks in each direction per axis, on 3 mutually perpendicular axes (total of 18 shocks)
• Noise Immunity	NEMA ICS3-304 RFI, (145 MHz, 440 MHz 10 W @ 10 cm) Impulse 1000 V @ 1 μ s pulse
• Enclosure	For use on a flat surface of Type 1, 4X enclosure (Indoor use only)
• Agency Approvals	CE (EN61131-2), UL508, CUL Canadian C22.2 No. 142-M95, UL File E157382, CSA 234884

Physical:

• Dimensions	4.311" (W) x 4.362" (H) x 2.035" (D) [109.5 mm x 110.8 mm x 51.7 mm]
• Enclosure Mounting Thickness Range	0.04" – 0.2" [1 – 5 mm]
• Mounting Clip Screw Torque Range	21 – 28 oz-in [0.15 – 0.2 Nm]
• Weight	14.99 oz. (425 g)

PLC Drivers

Serial - Panel port2 only

AutomationDirect Productivity Series
AutomationDirect CLICK
AutomationDirect K-sequence
AutomationDirect DirectNET
AutomationDirect SOLO
AutomationDirect GS Drives
AutomationDirect Modbus
Modicon Modbus RTU
Entivity Modbus RTU
Allen-Bradley DF1 Full Duplex
Allen-Bradley DF1 Half Duplex
Allen-Bradley PLC5 DF1
Allen-Bradley DH485
GE SNPX (90/30, 90/70, Micro 90, VersaMax Micro)
Mitsubishi FX
Mitsubishi Q and QnA
Omron Host Link (C200 Adapter, C500)
Omron FINS Serial (CJ1, CS1)
Siemens PPI (S7-200 CPU)



NOTE: EA1-T4CL cannot be powered by a PLC and cannot communicate with a PLC through Port1



For a list of supported protocols and cabling options refer to the 4" & 6" C-more Micro-Graphic Protocols and cabling chart starting on page 11-61.

C-more 6" Micro-Graphic Specifications

Specifications			
	EA1-S6ML	EA1-S6MLW	EA1-T6CL
Description	320 x 240 dots LCD display (Landscape Mode), five user defined keypad function buttons, and five user defined LED's		
Display			
• Type	5.7" STN monochrome LCD, graphical characters		5.7" TFT Color LCD, graphical characters
• Resolution	320 (W) x 240 (H) dots (Landscape Mode) 240 (W) x 320 (H) dots (Portrait Mode)		
• Color	2 colors (normal / inverse)		32768 colors
• Viewing Area Size	4.614" (W) x 3.480" (H) [117.2 mm x 88.4 mm]		4.574" (W) x 3.483" (H) [116.2 mm x 87.4 mm]
• Active Area Size	4.535" (W) x 3.400" (H) [115.2 mm x 86.4 mm]		
• Contrast	Adjusted from the panel's built-in configuration setup menu		
• Viewing Angle	3, 9 o'clock axis → 45 degrees 6 o'clock axis → 40 degrees 12 o'clock axis → 20 degrees		3, 9 o'clock axis → 50 degrees 6 o'clock axis → 50 degrees 12 o'clock axis → 45 degrees
Backlight			
• Type	LED		
• Color	5 user defined colors: EA1-S6ML - Red, Green, Amber, Lime, and Yellow EA1-S6MLW - White, Pink1, Pink2, Pink3 and Red		White
• User Replaceable	No		
Touch Screen			
• Type	Analog touch panel		
• Operation	82 gram force [0.8 N] maximum		
• Life	Minimum of 1,000,000 cycles		
Features			
• User Memory	1792 kBytes		3276 kBytes
• Number of Screens	Up to 999 – limited by project memory usage		
• Beep (Internal)	Yes		
• Keypad Function Buttons	Five user defined function key buttons with the ability to customize label with an overlay. Minimum of 500,000 cycles		
• Keypad Function Button LEDs	Each function key button includes a red LED that can be user programmed.		
• Programming Port	RJ12		USB Type B
• Serial Communications	Built-in RJ12 serial communications port (RS-232) and 15-pin D-sub serial communications port (RS-232, RS-485 / 422).		15-pin D-sub serial communications port (RS-232, RS-485 / 422)
• Expansion Connection	Yes – used with optional Keypad Bezels, EA-MG6-BZ2 & EA-MG6-BZP		
Screen Objects			
• Functional Devices	Push Button, Switch, Indicator Button, Indicator Light, Graphic Indicator Light, Numeric Display, Numeric Entry, Inc/Dec Value, Bar Graph, Bitmap Button, Static Bitmap, Dynamic Bitmap, Recipe Button, Static Text, Lookup Text, Dynamic Text, Screen Change Push Button, Screen Selector, Adjust Contrast, Function, Key Configuration Object, Real Time Graphics Line Graph, Analog Meter.		
• Static Shapes	Lines, Rectangles, Circles and Frames		
• Displayable Fonts	Fixed fonts: 4x6, 6x6, 6x6B, 6x8, 8x16, 8x32, 8x64, 16x16, 16x32, 16x64, 32x16, 32x32, 32x64, and Windows fonts		
Physical			
• Dimensions	6.850" (W) x 5.331" (H) x 2.130" (D) [174.0 mm x 135.4 mm x 54.1 mm] (Landscape Mode) 5.331" (W) x 6.850" (H) x 2.130" (D) [135.4 mm x 174.0 mm x 54.1 mm] (Portrait Mode)		
• Enclosure Mounting Thickness Range	0.04" – 0.2" [1 – 5 mm]		
• Mounting Clip Screw Torque Range	21 – 28 oz-in [0.15 – 0.2 Nm]		
• Depth from bezel rear with options Module	1.894" [47.1 mm]		
• Weight	30.69 oz (870g)		
C-more 6" Micro-Graphic panel specifications continued on next page.			

C-more 6" Micro-Graphic Specifications

Specifications			
	EA1-S6ML	EA1-S6MLW	EA1-T6CL
Physical			
• Dimensions	6.850" (W) x 5.331" (H) x 2.130" (D) [174.0 mm x 135.4 mm x 54.1 mm] (Landscape Mode) 5.331" (W) x 6.850" (H) x 2.130" (D) [135.4 mm x 174.0 mm x 54.1 mm] (Portrait Mode)		
• Enclosure Mounting Thickness Range	0.04" – 0.2" [1 – 5 mm]		
• Mounting Clip Screw Torque Range	21 – 28 oz-in [0.15 – 0.2 Nm]		
• Depth from bezel rear with options Module	1.894" [47.1 mm]		
• Weight	30.69 oz. (870 g)		
Environmental			
• Operating Temperature	0 to 50 °C (32 to 122 °F) Maximum surrounding air temperature rating: 50 °C		
• Storage Temperature	–20 to +60 °C (–4 to +140 °F)		
• Humidity	5–95% RH (non-condensing)		
• Environmental Air	For use in Pollution Degree 2 environment		
• Vibration	IEC60068-2-6 (Test Fc), 5-9 Hz: 3.5 mm amplitude, 9-150 Hz: 1.0G, sweeping, at a rate of 1 octave/min. (±10%), 10 sweep cycles per axis on each of 3 mutually perpendicular axes		
• Shock	IEC60068-2-27 (Test Ea), 15 G peak, 11 ms duration, three shocks in each direction per axis, on 3 mutually perpendicular axes (total of 18 shocks)		
• Noise Immunity	NEMA ICS3-304 RFI, (145 MHz, 440 MHz 10 W @ 10 cm) Impulse 1000 V @ 1 µs pulse		
• Enclosure	For use on a flat surface of Type 1, 4X enclosure (Indoor use only)		
• Agency Approvals	CE (EN61131-2), UL508, CUL Canadian C22.2 No. 142-M95, UL File E157382, CSA 234884		
C-more 6" Micro-Graphic panel specifications continued on next page.			



NOTE: The environmental specifications for the panels shown above are also applicable for the *C-more 6" Micro-Graphic* accessories shown later in this section of the catalog.

C-more Micro-Graphic Programming Software

FREE software!

C-more Micro-Graphic Programming Software can be downloaded at no charge or a CD version may be purchased by ordering EA-MG-PGMSW. The software requires a USB port on your PC to connect to the C-more Micro-Graphic panel. Software Help Files are included in the download. This software programs all the C-more Micro-Graphic panels (does not program the C-more 6" through 15" touch panels).



Note: This software is used to program C-more Micro-Graphic panels only.
Part Numbers: EA1-S3ML, EA1-S3ML-N, EA1-S3MLW, EA1-S3MLW-N, EA1-T4CL, EA1-S6ML, EA1-S6MLW, EA1-T6CL



NOTE: Software and Firmware Version 3.0 or later is required with model EA1-T4CL.
Software and Firmware Version 2.50 or later is required with model EA1-T6CL.
Software and Firmware Version 2.0 or later is required with models EA1-S6ML and EA1-S6MLW.
Software and Firmware Version 1.5 or later is required with models EA1-S3MLW and EA1-S3MLW-N.
Available for free download at www.automationdirect.com.

C-more Micro-Graphic Programming Software is a spin-off of its powerful sibling C-more Touch Panel. It offers very high end features designed to reduce your configuration time. Simply drag and drop the objects from the object list (right side of screen) onto the screen construction area. Then configure your PLC tags and click on the objects you wish to use. Use the built-in simulator to review your work on your PC before ever downloading your project! The time saving benefits of the C-more Micro-Graphic configuration software could easily pay for the panel. Check out www.CmoreMicro.com to download a free version.

Thumbnail project preview pane

Helps keep track of multi-screen projects.

Built-in project simulator

- Runs your project on your PC
- Test all of your screens before downloading
- Time savings pays for the panel
- Version 2.5 or later - Simulate function keys and keypad bezel.

Built-in user object/screen libraries

Save time by re-using your custom objects and screens.

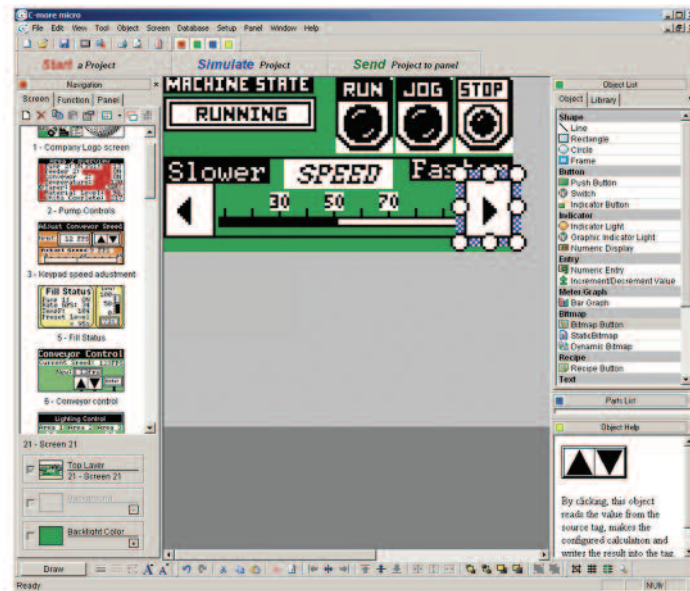

Scrolling object selection window

Lets you find the object you want fast. Just drag and drop it on the screen.

PC requirements

Following are the minimum system requirements for running C-more Micro-Graphic Programming Software, EA-MG-PGMSW, on a PC:

- Personal Computer with a 333 MHz or higher processor (CPU) clock speed recommended;
- Keyboard and Mouse or compatible pointing device
- Super VGA color video adapter and monitor with at least 800 x 600 pixels resolution (1024 x 768 pixels recommended) 64K color minimum
- 150 MB free hard-disk space
- 128 MB free RAM (512 MB recommended); 512 MB free RAM (1GB recommended) for Vista
- CD-ROM or DVD drive for installing software from the CD, or internet access to download free programming software
- USB port to use with an EA-MG-PGM-CBL, USB to RS232 Programming Cable Assembly for project transfer from the programming software to the STN, panels, or USB-CBL-AB6 for TFT panels
- Operating System - Windows® XP Home / Professional Edition Service Pack 2, Windows® 2000 with Service Pack 4, Windows® Vista or Windows® 7.

Scrolling help window

Gives you helpful information on each object

C-more Micro-Graphic Programming Software

C-more Micro-Graphic Panel Objects			
Object	Graphic	Object	Graphic
The Line object, just like with drawing tools, allows the user to insert a straight line drawing into a project. When a line is inserted into a project, a window opens to allow the user to setup all available parameters for the Line object. Some of the uses for Line Objects include but are not limited to adding callouts, pointers, or indicators.		The Analog Meter object is used to display the current value of a Tag Name.	
The Rectangle object, just like with drawing tools, allows the user to insert a drawing of a Rectangle as well as other geometric shapes into a project. When this object is inserted into a project, a window opens to allow the user to setup all available parameters for the Rectangle object.		The Bar Meter object is used to monitor up to two assigned Tag Names continuously. This object has various appearances depending upon the relative value of the tags. The Bar Meter can be used to create digital versions of level, current, and flow meters to name a few samples, or gauges that measure speed and other measurable data.	
The Circle object, just like with drawing tools, allows the user to insert a drawing of a Circle or ellipse shape into a project. When this object is inserted into a project, a window opens to allow the user to setup all available parameters for the Circle object.		The Bitmap Button object offers the ability to use a Bitmap graphic to perform the functions of a Button. This allows users to create their own graphics and implement them within the software project. The Bitmap Button object can be used to activate or deactivate components assigned to a Discrete Tag Name. The C-more Micro-Graphic display only supports two colors, black and white.	
The Frame object allows the user to insert a Frame to the project that can be used to Frame other objects. Some of the uses for Frame object include but are not limited to graphically separating objects for different operations that may appear on one screen and emphasizing pushbuttons or other objects that may require more attention by the operator.		The Static Bitmap offers the ability to display a Bitmap graphic on any screen. The Static Bitmap does not change state. Refer to the Dynamic Bitmap Object if you require the graphic object to change state based on a Tag Value in your PLC. The dialog box for a "Static Bitmap" object allows you to "read from disk" and select a graphic file for import. Graphics must be in one of the following formats: .BMP .WMF .JPG .JPEG	
The Pushbutton object is available from the Button Category of the Object List window. The Pushbutton object is an electronic version of a typical Pushbutton normally found on control panels. The Pushbutton object can be used to activate or deactivate components assigned to a Discrete Tag Name.		Recipe objects make it easy to make a large number of tag changes with the push of a single button. Create Recipes with up to 99 entries, and multiple sets of values. Then just push a button to load an entire set of values into the group of recipe tags.	
The Switch object is an electronic version of a typical Switch that normally can be found on control panels. The Switch object can be used to activate or deactivate components assigned to a Discrete Tag Name.		The Dynamic Bitmap object offers the ability to make an object using two different Bitmap graphics that will display one graphic when the Tag is On and a different graphic when the Tag is Off. Use your own bitmap designs or use some of the bitmaps provided with the software that are located in the User Graphic Library.	
The Indicator Button object is available from the Button Category of the Object List window. The Indicator Button object is an electronic version of a typical Indicator Button normally found on control panels. The Indicator Button is a combination of a Pushbutton and an Indicator Light. The Indicator Button can be used to activate or deactivate components assigned to a Discrete Tag Name.		The Static Text object is used to display a Frame with a personalized Message. This Frame and Message can be placed on any screen and any location within the screen.	
The Indicator Light object is an electronic version of a typical Indicator Light normally found on industrial control panels. The Indicator Light can be configured to display the status of the assigned Discrete Tag Name.		The Lookup Text object is used to display a Frame with a personalized Message. This Frame and Message can be placed on any screen and any location within the screen. The object is always displayed like a sign but is configured to display only the message prompted by an assigned Tag Name. Messages are retrieved from a Message Database which is configured by the user with text defined by the user. The Lookup Text Object will scroll text up to 128 characters.	
The Graphic Indicator Light object is a more enhanced version of the "Indicator Light Object" that allows the user to choose more detailed graphics to display the status of a tag. This object is an electronic version of a typical Indicator Light normally found on industrial control panels. The Indicator Light can be configured to display the status of the assigned Discrete Tag Name.		The Dynamic Text object is used to display text that is retrieved from data stored in a Tag. The Tag Name is assigned to registers in the PLC that contain set character data. The data can be stored in the PLC in ASCII format and may include information such as machine numbers, locations, part numbers, and such. The Message can be configured to be visible (Trigger) when an associated Tag Name is On or Off. This object can be placed on any screen and any location within the screen. The Dynamic Text Object will scroll text up to 40 characters.	
The Numeric Display consists of a frame that displays a real-time numeric value according to the value of data received from an assigned Tag Name. The Numeric Display supports numeric Signed Decimal, Unsigned Decimal, BCD, and Floating Point data types with up to 11 digits, including decimal point. User Defined Alpha Numeric Prefix and Suffix values are also supported.		The Scroll Text object is available from the Text Category of the Object List window. The Scroll Text object is an electronic version of a marquee. It is similar to the Static Text Object. If the text in the object does not fit in the window, it will scroll from right to left across the window. The Scroll Text object does not require a Tag Name assignment. The Scroll Text Object has a maximum character limit of 128 characters.	
The Numeric Entry object is used to enter a value from your Panel to a PLC Register. This object, when selected, opens a Numeric Keypad that allows the user to enter a new value that will be written to the assigned Tag Name. The Numeric Entry supports numeric Signed Decimal, Unsigned Decimal, BCD, and Floating Point data types with up to 11 digits, including decimal points. User Defined Alpha Numeric Prefix and Suffix values are also supported.		The Screen Change Pushbutton object is available from the Control Category of the Object List window. The Screen Change Pushbutton object is a pushbutton that can be configured to activate another screen in the project. This object may be edited to various colors and sizes. Users can configure the button to activate the Power-Up screen, Forward Screen, Previous Screen, or any one of the project screens.	
The Increment/Decrement Value object is used to add or subtract a value by pressing a button on the Panel. Basically the object uses two Tags, one to read a value from and another to write a modified value to. The Increment/Decrement Value supports numeric Signed Decimal, Unsigned Decimal, BCD, and Floating Point data types with up to 11 digits, including decimal points. The Increment and decrement values are also user selectable.		The Screen Selector object is available from the Control Category of the Object List window. This object is an enhanced version of the Screen Change pushbutton in that it offers many more features and defaults with data from screens in the project. This helps to save time by not having to create Screen change buttons for each screen. This object may be edited to various colors and sizes.	
The Real Time Graph object displays the value stored in up to two PLC tags, over a history of up to 24 points each. One point is added at each refresh.		The Adjust Display Contrast object is used to allow the operator to adjust the Panel Display Contrast. The default Display setting often works in most applications, however lighting may vary based on the location of each application. In these cases the operator can use this object to make adjustments. The current display setting value will appear on the top of the button and will change as the arrow keys are pressed. This button can be modified to various sizes.	
The Line Graph object displays the values of up to 24 PLC address points. Up to two address arrays can be displayed. The line is drawn in its entirety at each refresh.		The Function object is used to assign the panels function key buttons to a particular action as well as assigning the control of the LED On/Off status. When a button has been assigned as a shift button, the then F1 through F5 will become F6 through F10. The Function Object buttons will activate when the hardware button is pressed or when the object is pressed on the screen. The object size is restricted so that the keys will line up with the hardware function keys on the panel.	