

DL05/06 I/O Option Modules

D0-10ND3F <--->

10-point DC fast input module

D0-10ND3F Input Specifications	
Number of Inputs	10 (sink/source)
Input Voltage Range	10.8-26.4 VDC
Peak Voltage	30.0 VDC
Input Current	Typical: 4.0 mA @ 12 VDC 8.5 mA @ 24 VDC
Maximum Input Current	11 mA @ 26.4 VDC
Input Impedance	2.8 kΩ @ 12-24 VDC
On Voltage Level	> 10.0 VDC
Off Voltage Level	< 2.0 VDC
Minimum ON Current	3.5 mA
Minimum OFF Current	0.5 mA
Off to On Response	2 ms, Typ. 1 ms
On to Off Response	2 ms, Typ. 1 ms
Status Indicators	Module activity: one green LED
Commons	2 (5 pts/common) isolated
Fuse	No fuse
Terminal Type (Included)	Removable: D0-ACC-4
Base Power Required (5V)	Typical. 35 mA (all pts. on)

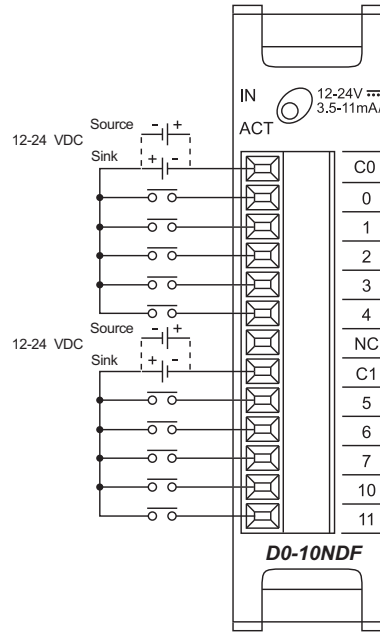

CPU	Firmware Required	DirectSOFT Required
DL05	Version 4.70 or later	Version 3.0c or later
DL06	Version 1.50 or later	Version 4.0, Build 16 or later



See page 2-68 for part numbers of ZIPLink cables and connection modules compatible with this I/O module.

Derating chart

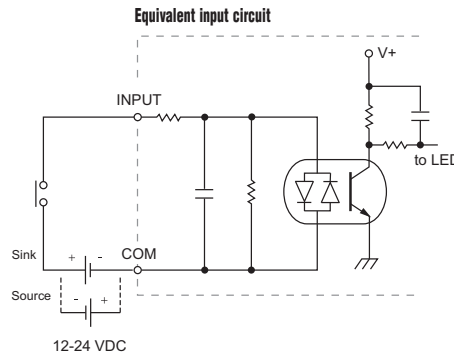
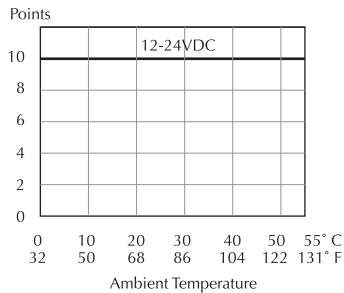

For "Sinking and Sourcing Concepts", see the Appendix section in this catalog.

Cut PLC wiring time to minutes instead of hours

The ZIPLink wiring system eliminates the normally tedious process of wiring PLC I/O to terminal blocks. Simply plug one end of a ZIPLink pre-wired terminal block cable into your I/O module and the other end into a ZIPLink connector module. It's that easy. ZIPLinks use half the space, at a fraction of the total cost of terminal blocks.

ZIPLinks are available in a variety of styles to suit your needs, including fused, relay and sensor/LED connector modules. ZIPLinks are available for all DL05/06 Series PLC discrete and analog input and output modules.

For complete information see ZIPLinks in the Terminal Blocks and Wiring Solutions section.



Specify your ZIPLink system

Use the Compatibility Matrix table below:

Step 1	Locate the I/O Module part number.
Step 2	Locate Connector Module Type. (Feedthrough Module, Fuse Module, etc...)
Step 3	Select the cable length by replacing the # symbol with: Blank = 0.5m, -1 = 1m, -2 = 2m ¹
¹ Note: Cable part number denotes compatibility between Connector Module and I/O Modules.	

ZIPLink Wiring System Compatibility Matrix for DL05/06 PLCs						
Step 2: Connector Module Type		Feedthrough Modules	Fuse Modules	Relay Modules	Sensor Input Modules	Pigtail Cable
Step 1: I/O Module	Number of Terminals	Step 3: Cables				
Inputs						
DO-10ND3	13	ZL-D0-CBL13#				
DO-10ND3F	13	ZL-D0-CBL13#				
DO-16ND3	24	ZL-D0-CBL24#L			ZL-D0-CBL24#L	ZL-D0-CBL24#P
FO-08NA-1	10	ZL-D0-CBL10#				
Outputs						
DO-10TD1	13	ZL-D0-CBL13#				
DO-16TD1	24	ZL-D0-CBL24#	ZL-D0-CBL24#	ZL-D0-CBL24#		ZL-D0-CBL24#P
DO-10TD2	13	ZL-D0-CBL13#				
DO-16TD2	24	ZL-D0-CBL24#	ZL-D0-CBL24#			ZL-D0-CBL24#P
DO-08TR	10	ZL-D0-CBL10#				
FO-04TRS*	13	ZL-D0-CBL13#				
Combo In/Out						
DO-07CDR	10	ZL-D0-CBL10#				
DO-08CDD1	13	ZL-D0-CBL13#				
Analog						
FO-04AD-1	8	ZL-D0-CBL8#				
FO-04AD-2	8	ZL-D0-CBL8#				
FO-08ADH-1	13	ZL-D0-CBL13#				
FO-08ADH-2	13	ZL-D0-CBL13#				
FO-04DAH-1	13	ZL-D0-CBL13#				
FO-08DAH-1	13	ZL-D0-CBL13#				
FO-04DAH-2	13	ZL-D0-CBL13#				
FO-08DAH-2	13	ZL-D0-CBL13#				
FO-2AD2DA-2	8	ZL-D0-CBL8#				
FO-4AD2DA-1	8	ZL-D0-CBL8#				
FO-4AD2DA-2	8	ZL-D0-CBL8#				
FO-04RTD**						
FO-04THM**						

* Caution: The FO-04TRS relay outputs are derated not to exceed 2 Amps per point when used with the ZIPLink wiring system.

** The F2-04RTD and F2-04THM modules are not supported by the ZIPLink wiring system. These modules require wire specific to the signal type.

ZIPLink Connector Modules specifications begin on page 26-56

ZIPLink Cables specifications begin on page 26-74