



# D3-350 Key Features

The D3-350 supports over 130 instructions. These include:

- Four types of drum sequencers
- Leading and trailing edge triggered one-shots
- Bit of word manipulation
- Floating point conversions
- Print instruction to send ASCII data through the bottom CPU port

For a complete list of instructions supported by the D3-350 CPU, see the end of this section.

## On-board flash memory

The D3-350 has 7.6 K of flash memory on board. With flash memory, you don't have to worry about losing the program due to a bad battery. If you have critical data stored in V-memory, like PID loops, simply purchase the optional lithium battery to maintain these parameters as well.

## Built-in remote I/O connection

The bottom port on the D3-350 can also be used as a master for a remote I/O network. If you need extra I/O at some remote distance from the CPU, use this port to add up to seven DL205 remote slave stations. (See the DL205 section for D2-RSSS information.)

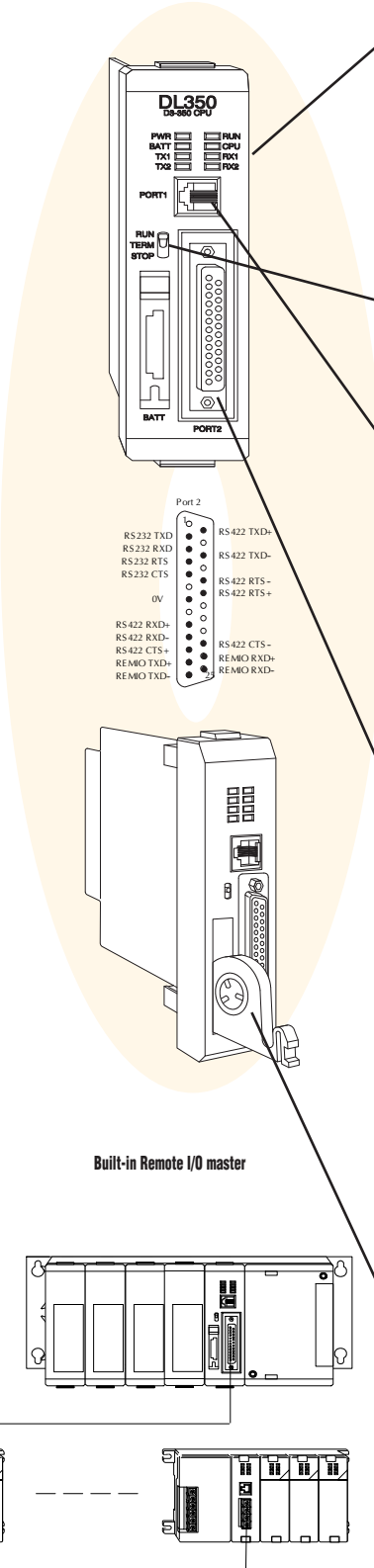

CPU Status Indicators		
<b>RUN</b>	ON	CPU is in RUN mode
	OFF	CPU is in Program mode
<b>BATT</b>	ON	Battery backup voltage is low
	OFF	Battery backup voltage is OK or disabled
<b>CPU</b>	ON	CPU internal diagnostics has detected an error
	OFF	CPU is OK
<b>PWR</b>	ON	CPU power good
	OFF	CPU power failure
Mode Switch		
<b>RUN</b>	Forces CPU into Run Mode	
<b>TERM</b>	Allows peripherals (HPP, <i>DirectSOFT</i> and operator interface panels) to write to the CPU.	
<b>STOP</b>	Forces CPU out of RUN mode	
Port 1		
<b>Protocols</b>	K-sequence slave <i>DirectNET</i> slave	
<b>Devices</b>	Can connect w/HPP, <i>DirectSOFT</i> , DV-1000, <i>C-more</i> Panels, or any <i>DirectNET</i> Master	
<b>Specs.</b>	6P6C phone jack connector RS232C 9600 baud Odd parity Fixed station address 1 8 data bits 1 start, 1 stop bit Asynchronous, half-duplex, DTE	
Port 2		
<b>Protocols</b>	K-sequence slave <i>DirectNET</i> Master/slave MODBUS RTU Master/slave Remote I/O Master	
<b>Devices</b>	Can connect w/many devices, such as PCs running <i>DirectSOFT</i> , <i>KEPdirect</i> for PLCs Server, HMI packages, DV-1000, <i>C-more</i> panels, or any <i>DirectNET</i> or MODBUS RTU master or slave	
<b>Specs.</b>	25-pin D-shell connector RS232C/RS422 300/600/1200/2400/4800/9600 19.2K/38.4K Baud Odd, even or no parity Selectable address (1-90, HEX 1-5A) 8 data bits-1 start, 1 stop bit Asynchronous, half-duplex, DTE	
Batteries (optional)		
<b>D2-BAT-1</b>	D3-350 only, coin type 3.0V Lithium battery, 560mA battery # CR2354	

**Note:** Batteries are not needed for program backup. However, you should order a battery if you have parameters in V-memory that must be maintained in case of a power outage, such as PID loops.

...allows you to connect up to seven DL205 remote slaves!

# D3-350 PID Loop Specifications

PID Loop Specifications and Key Features	
<b>Number of Loops</b>	Selectable, four maximum
<b>CPU V-Memory Required</b>	32 V-memory locations per loop selected (additional 32 V-memory locations per loop required if using Ramp/Soak)
<b>PID Algorithm</b>	Position or velocity form of the PID equation. direct or reverse acting, square root of the error and error squared control.
<b>Auto Tuning</b>	Open-loop step response method and closed-loop limit cycle method.
<b>Sample Rate</b>	Specify the time interval between PV samples, 0.05 to 99.99 seconds. Smallest sample rate is limited to either 0.05 seconds or (PLC scan time x number of loops).
<b>Loop Operation Modes</b>	Loops can be in automatic control, manual (operator) control, or cascade control. PV alarm monitoring continues when loops are in manual mode.
<b>Ramp/Soak</b>	Up to 16 steps (8 ramp, 8 soak) per loop, with indication of ramp/soak step.
<b>Square Root PV</b>	Specify a Square root of the PV for a flow control application.
<b>Limit SP</b>	Specify a maximum and minimum value for allowable setpoint changes.
<b>Limit Output</b>	Specify a maximum and minimum value for the output range.
<b>Gain</b>	Specify proportional gain of 0.01 to 99.99.
<b>Reset</b>	Specify integral time of 0.1 to 999.8 in units of seconds or minutes.
<b>Rate</b>	Specify the derivative time, 0.00 to 99.99 seconds.
<b>Rate Limiting</b>	Specify a derivative gain limiting coefficient to filter the PV used in calculating the derivative term (0 to 20).
<b>Bumpless Transfer I</b>	Bias and setpoint are initialized automatically when the module is switched from manual to automatic. This provides for a bumpless transfer, which reduces the chance of sharp changes in the output as a result of entering automatic mode.
<b>Bumpless Transfer II</b>	Bias is set equal to the output when the module is switched from manual to automatic. This allows switching in and out of automatic mode without having to re-enter the setpoint.
<b>Error Deadband</b>	Specify an incremental value above and below the setpoint in which no change in output is made.
<b>Error Squared</b>	Squaring the error minimizes the effect a small error has on the Loop output, however both Error Squared and Error Deadband control may be enabled.
Alarm Specifications	
<b>Deadband</b>	Specify 0.1% to 5% alarm deadband on all alarms except rate of change.
<b>PV Alarm Points</b>	Specify PV alarm settings for low-low, low, high, and high-high conditions. You can also specify a deadband to minimize the alarm cycles when the PV approaches alarm limits.
<b>PV Deviation</b>	Specify alarms to indicate two ranges of PV deviation from the setpoint value (yellow and red deviation).
<b>Rate-of-Change</b>	Specify a rate-of-change limit for the PV.

# CPU Specifications

DL305 CPU Specifications			
System Capacity	D3-330	D3-340	D3-350
Total memory (K words)	3.91	3.98	14.8
Ladder memory (K words)	3.7	3.7	7.6
User data memory	116 bytes	172 bytes	7.1K words
CMOS RAM	Yes	Yes	No
UVEPROM	Opt.	Opt.	No
EEPROM	No	Opt.	Flash
Total I/O points using:			
Local I/O	128	136	144
Local and Expansion I/O	176	184	368
Remote I/O <sup>1</sup>	N/A	N/A	512
I/O point density	8/16	8/16	8/16
Slots per base (CPU requires 1 slot)	5/8/10	5/8/10	5/8/10
Performance			
Contact execution (boolean)	6.6µs	.87µs	.61µs
Typical scan (1K boolean) <sup>2</sup>	15ms	4-5ms	5-6ms
Programming & Diagnostics			
RLL ladder style	Yes	Yes	Yes
RLL <sup>PLUS</sup> (stage)	No	No	Yes
RunTime Editing	No	No	Yes
Supports Overrides	No	No	Yes
Variable/fixed scan	variable	variable	either
Handheld programmer port	Yes	Yes	Yes
Built-in RS232C ports	No <sup>3</sup>	2	2
Real-time clock/calendar	No	No	Yes
Instructions	61	63	129
Control relays(CR)	140	196	1024
Shift register bits	128	128	use CRs
Stages (RLL <sup>PLUS</sup> only)	N/A	N/A	1024
Timers/counters	64	64	256/128
Immediate I/O	No	No	Yes
Subroutines	No	No	Yes
For/Next Loops	No	No	Yes
Timed interrupt	No	No	Yes
Integer math	Yes	Yes	Yes
Floating point math	No	No	Yes
PID	No	No	Yes
Drum sequence	No	No	Yes
Bit of word	No	No	Yes
ASCII print	No	No	Yes
Data registers	128	192	7168
Internal diagnostics	Yes	Yes	Yes
Password security	Yes	Yes	Multi-level
Battery backup	Yes	Yes	Yes
Communications			
Built-in ports <sup>3</sup>	No	Yes	Yes
<b>DirectNET</b> master	No	Yes	Yes
<b>DirectNET</b> slave	w/DCU	Yes	Yes
MODBUS RTU master	No	No	Yes
MODBUS RTU slave	No	Yes	Yes
Data communications unit	Yes	Yes	N/A
Specialty modules			
Thermocouple	Yes	Yes	Yes
Analog Input (#channels max.)	112	128	368
Analog output (#channels max.)	28	32	48
High-speed counter (10KHz)	Yes	Yes	No



1. The D3-350 bottom port supports DL205 remote I/O.
2. 1K program includes contacts, coils, and scan overhead. If you compare to other products, make sure to include their scan overhead.
3. The D3-330 requires a Data Communications Unit (DCU) for programming with DirectSOFT software.

# Communications

## Determine your communications requirements

The choice of CPU can have a big impact on your communications capabilities in the DL305 family. If you are considering doing any communications, you should use the D3-340 or the D3-350 CPUs. You can communicate with the D3-330 CPU, but you have to add a DL305 Data Communications Unit to connect any device other than a handheld programmer. The Data Communications Unit has only one port.

D3-340 RS232C Communication Port Specifications	
Protocol	DirectNET
Connector	RJ11(handset connector)
Network address	01 to 90
Baud rate	38400, 19200, 9600, 4800, 2400, 1200, 600, 300
Parity-	None or odd
Transfer mode	HEX/ASCII Half-duplex Asynchronous
Data bits	8
Start bits	1
Stop bits	1
Turn around delay	0 to 1980 in 20ms intervals (preset with R777)

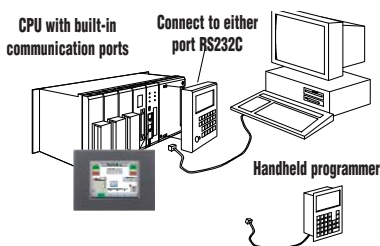

Network Addresses		
Port	Protocol	Range
1	Slave	1-90
2	Slave	1-90
	Master	0
	MODBUS/RTU	1-247

## Standard communications

The D3-340 and D3-350 CPUs offer two built-in RS232C communication ports. Operator interfaces and **DirectSOFT** can be connected to either port. On the D3-340 CPU, the handheld programmer is attached directly or with a cable to the parallel port adjacent to the two serial communication ports. On the D3-350 CPU, the handheld programmer is attached to Port 1. The handheld programmer can be operated simultaneously with the communication ports. The D3-340 baud rate and network addresses are set by hardware dipswitches and rotary switches for Port 1. Port 2 uses internal registers that can be changed with a handheld programmer or **DirectSOFT**. Port 1 on the D3-350 is fixed. Port 2 can be configured using the handheld programmer or **DirectSOFT**.

## DL305 as a slave on a network

Both ports on the D3-340 and the D3-350 CPUs can serve as slave ports for **DirectNET**. The bottom ports offer additional flexibility in that they can serve as a slave on a Modbus RTU network. The D3-350 even supports RS422, so no RS232-to-RS422 converter is needed. No programming is required in these CPUs for them to act as slave ports.

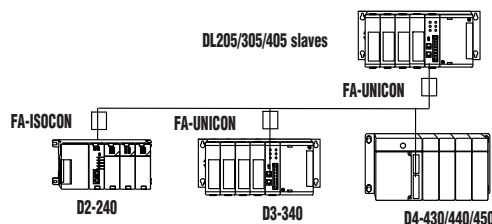

## DL305 as a network master

The bottom built-in communication port of the D3-340 and D3-350 CPUs can serve as a Network Master for **DirectNET**. Up to 90 slave stations can be addressed. The D3-350 can also serve as a MODBUS RTU Master; up to 247 slave stations can be addressed. DL405, DL305 and DL205 controllers can be used as slave stations. (Please note there are certain restrictions pertaining to valid DL205 and DL405 memory types that the D3-340 master can read and write.)

## Custom drivers

The DL305 product family supports the **DirectNET** protocol. However, in some applications you may have a need to connect to a device that does not support this protocol. If so, the ASCII/BASIC modules also allow you to write your own custom communication drivers (in BASIC) to connect to special devices. These high-speed modules offer communication rates up to 115.2K baud on RS232C, RS422, and RS485. With 128K of memory, there is ample program or data storage space. (These modules are not supported by the D3-350.)