

Built-in High-Speed I/O Features

Overview

You can use the DL05 or DL06 PLCs to solve a diverse range of motion and high-speed machine control applications.

DC input and DC output versions of the DL05 and DL06 PLCs offer built-in high-speed input and pulse output features. On DL05 PLCs with DC inputs, the high-speed features are accessible on the first three input points (X0-X2). On DL06 PLCs with DC inputs, the high-speed features are accessible on the first four input points (X0-X3). On DL05 or DL06 PLCs with DC outputs, the pulse output feature is accessible on the first two output points (Y0-Y1).

Several modes of operation are available that meet the needs of many applications. The operating modes are explained in detail in the DL05 and DL06 PLC User Manuals. Only one high-speed I/O mode can be in use at one time. You cannot use a high-speed input feature and the pulse output feature at the same time. A brief description of each high-speed mode is listed below:

Mode 10 - High-speed counters offer 24 presets. When the preset is reached, an interrupt routine is executed (max. count: 99,999,999)

Mode 20 - Quadrature encoder input (up/down counter) for clockwise and counterclockwise position control (max count: 0 to 99,999,999 unipolar or -8,388,608 to 8,388,607 bipolar)

Mode 30 - Pulse outputs are programmable to follow a predetermined profile. An external interrupt can be used in conjunction with separate acceleration/deceleration profiles for positioning and velocity control (max. pulse range: -8,388,608 to 8,388,607)

Mode 40 - External interrupt inputs can be used for an immediate response to urgent application tasks

Mode 50 - The pulse catch input allows the CPU to read an input with a pulse width as narrow as 0.1ms

Mode 60 - Input filters are configurable (0-99ms) to ensure input signal integrity. The default input mode is a 10ms filter

Mode 40 option - Timed interrupts can be configured for time critical events. Interrupt 0 can be scheduled on a 5ms-999ms cycle. Interrupt 1, available on the DL05, can be scheduled on a 5ms-9999ms cycle

DL05 High-speed I/O Features					
Mode*	DC Inputs Points			DC Output Points	
	X0	X1	X2	Y0	Y1
Mode 10: High-Speed Up Counter	Counter input	Filtered input	Reset count Filtered input	Regular output	Regular output
Mode 20: Quadrature Counter	Phase A input	Phase B input	Reset count Filtered input	Regular output	Regular output
Mode 40: High-Speed Interrupt	Interrupt input	Filtered input	Filtered input	Regular output	Regular output
Mode 50: Pulse Catch	Pulse input	Filtered input	Filtered input	Regular output	Regular output
Mode 30: Pulse Output	Filtered input	Filtered input	Positioning interrupt Filtered input	Pulse CW pulse	Direction CCW pulse
Mode 60: Filtered Input	Filtered input	Filtered input	Filtered input	Regular output	Regular output

DL06 High-speed I/O Features						
Mode*	DC Inputs Points				DC Output Points	
	X0	X1	X2	X3	Y0	Y1
Mode 10: High-Speed Up Counter	Counter Ch 1	Counter Ch 2 Interrupt Pulse input Filtered input	Reset Ch 1 Interrupt Pulse input Filtered input	Reset Ch 2 Interrupt Pulse input Filtered input	Regular output	Regular output
Mode 20: Up/Down Counter	Up input	Down input	Reset Pulse input Filtered input	Pulse input Filtered input	Regular output	Regular output
Mode 20: Quadrature Counter	Phase A input	Phase B input	Reset Pulse input Filtered input	Pulse input Filtered input	Regular output	Regular output
Mode 40: High-Speed Interrupt	Interrupt input	Interrupt Pulse input Filtered input	Interrupt Pulse input Filtered input	Interrupt Pulse input Filtered input	Regular output	Regular output
Mode 50: Pulse Catch	Pulse input	Interrupt Pulse input Filtered input	Interrupt Pulse input Filtered input	Interrupt Pulse input Filtered input	Regular output	Regular output
Mode 30: Pulse Output	Filtered input	Interrupt Pulse input Filtered input	Pulse input Filtered input	Pulse input Filtered input	Pulse CW Pulse	Direction CCW pulse
Mode 60: Filtered Input	Filtered input	Filtered input	Filtered input	Filtered input	Regular output	Regular output

*The high-speed input features cannot be used if the pulse output features are in use, and vice versa.

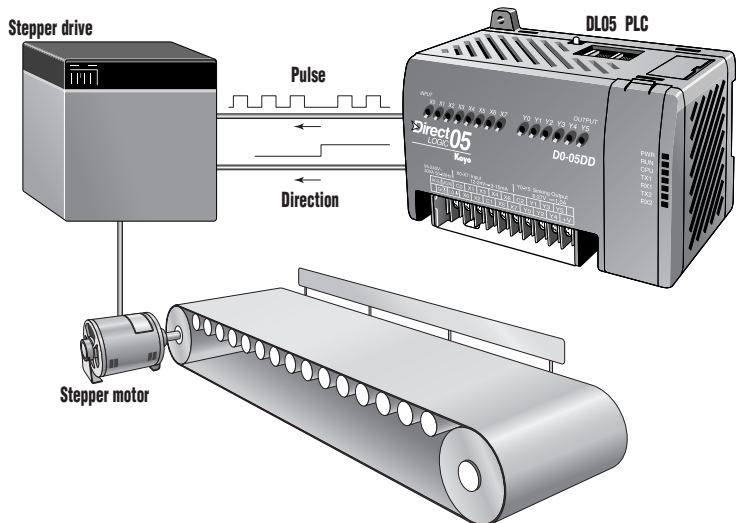

Built-in High Speed I/O Specifications

High-Speed Input Specifications		
PLC	DL05	DL06
High-speed Inputs	3 pts. sink or source (X0-X2)	4 pts. sink or source (X0-X3)
Max. Input Frequency	5kHz	7kHz
Minimum Pulse Width	100 μ s	70 μ s
Input Voltage Range	12-24 VDC	
Input Impedance (hs only)	1.8K @ 12-24VDC	
ON Current/Voltage Level	>5mA/>10VDC	
OFF Current/Voltage Level	<0.5mA/<2VDC	
OFF to ON Response	<100 μ s	<70 μ s
ON to OFF Response	<100 μ s	<70 μ s

High-Speed Output Specifications		
PLC	DL05	DL06
Pulse Outputs	2 pts. (Y0 and Y1) current sinking	2 pts. (Y0 and Y1) current sinking or sourcing (sourcing outputs on DO-06DD2 only)
Max. Output Frequency	7kHz	10kHz
Voltage Range	6-27VDC	
Max. Load Current	0.5A/point	
ON Voltage Drop	0.3VDC @ 1.0A	
Leakage Current	15 μ A @ 30VDC	
Inrush Current	2A (100ms)	
OFF to ON Response	<10 μ s	<10 μ s
ON to OFF Response	<30 μ s	<20 μ s

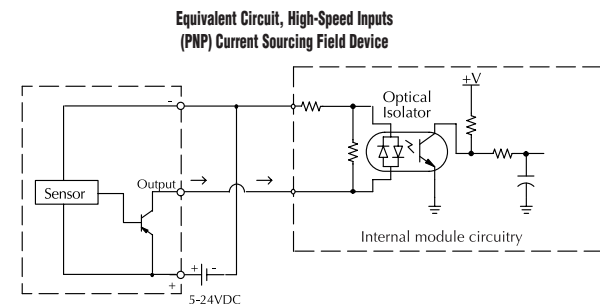
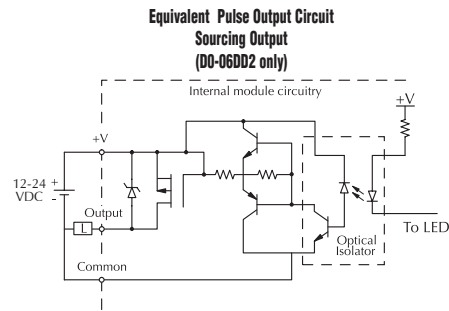
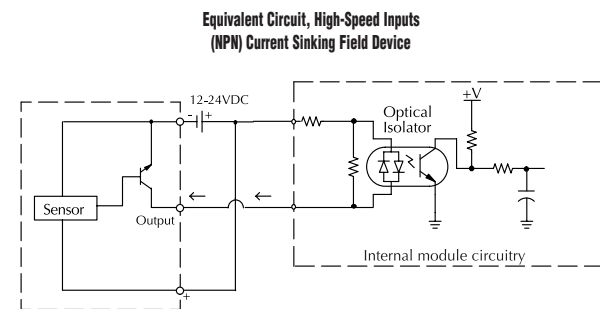
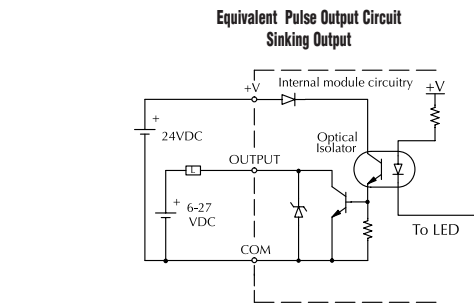
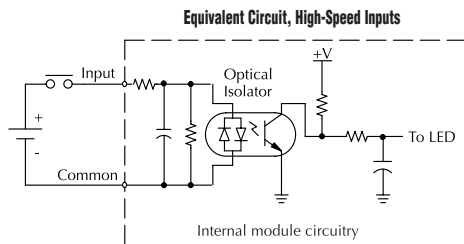
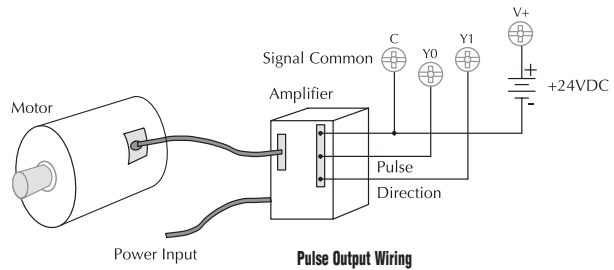
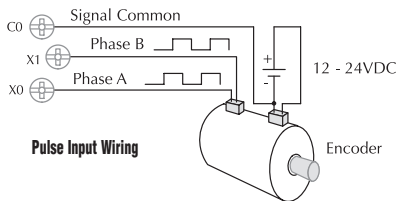

Timed Interrupt Feature

Time-based interrupts

There is also a timed interrupt feature available in the DL05 and DL06 PLCs. This cyclical interrupt allows you to program a time-based interrupt that occurs on a scheduled basis. This feature is available in all units, regardless of input type.

The CPU's timed interrupt operates in a similar manner to the external interrupt input, but instead of the interrupt subroutine being triggered by an external event tied to X0, it is triggered by a cyclical interval of time. This interval can be programmed from 5 ms to 999 ms for INT0, which is available on either the DL05 or the DL06. The programmable time interval for INT1, which is available on the DL05, is 5 to 9999 ms.

Whenever the programmed time elapses, the CPU immediately suspends its routine scan cycle and jumps to the selected interrupt subroutine. As with the other modes, when the interrupt subroutine execution is complete, the CPU automatically resumes its routine scan cycle starting from the location where it was interrupted. Because the CPU scan time and the interrupt time interval are different, the point at which the RLL program is interrupted can change over time.

A note on timed interrupts

DL06: If you use the external hardware interrupt (mode 40), you cannot use the timed-based internal interrupt INT 0. You can use either one, but not both. This is because they share the same interrupt routine, INT 0.

DL05: The DL05 offers a second timed-based interrupt INT 1. This allows you to use an external hardware interrupt and/or a timed-based interrupt.

DL05 time-based interrupt

DL05 Designated Terminals

X0: Filtered input (uses filter time set for X1)

Timed Interrupt Specifications

Timed interrupts: 2 (internal to CPU)
 Interrupt Subroutine INT0, INT1
 Time interval:
 INT0 5 to 999 ms (1 ms increments)
 INT1 5 to 9999 ms (1 ms increments)

DL06 time-based interrupt

DL06 Designated Terminals

X0: Filtered input (uses filter time set for X1)

Timed Interrupt Specifications

Timed interrupts: 1 (internal to CPU)
 Interrupt subroutine INT0
 Time interval:
 INT0 5 to 999 ms (1 ms increments)

Timed interrupt operation

