

The HT800 family of 30.5 mm pushbutton devices includes momentary, illuminated and mushroom-head pushbuttons, selector switches, indicating lights and push-pull switches.

## Features

- Anodized aluminum mounting rings
- Watertight double V-gasket seals
- Extended height bulbs
- Transparent housing contact blocks
- Color-coded contact blocks
- Gold-plated contacts (on low voltage contact block)
- Reliability ridge on movable contact
- Stackable screw-mounted contact blocks
- Contact blocks can be mounted in left/right or top/bottom positions
- Standard N.C. contact opens before N.O. contact closes (break before make operation)
- Bright and long lasting LED indicating lights in six colors
- Field convertible maintained selector switches from two-position to three-position and vice versa
- Field selectable knob/lever mounting positions – at any 22.5° increment

## Benefits

- Corrosion resistant NEMA 4X finish
- Watertight and oil-tight NEMA 4, 13 ingress protection
- Increased side illumination of indicating lights and illuminated pushbuttons
- Easy visual inspection of contact conditions
- Easily identifiable N.O. (white) or N.C. (black) contact blocks
- Gold-plated contacts suitable for logic level circuits
- Reliability ridge penetrates contamination buildup on stationary contacts
- Left/right or top/bottom mounted contact blocks allow correct positioning in retrofit applications
- All-purpose selector switches are convertible and can rotate in 22.5° increments to suit panel layouts

## Standards and Certifications

- UL508, File No. E131568
- CSA C22.2 No. 14, File No. LR68551

## Ingress Protection

- UL (NEMA) 1, 2, 3, 3R, 4, 4X, 12 and 13 when mounted in similarly rated enclosures

HT800 — Specifications	
<b>Mechanical Ratings</b>	
<b>Frequency of Operation</b>	
<b>Pushbuttons</b>	6,000 Operations per hour
<b>Selector Switches</b>	3,000 Operations per hour
<b>Push-Pull Operators</b>	3,000 Operations per hour
<b>Mechanical Endurance/Life</b>	
<b>Pushbuttons</b>	10 x 10 <sup>6</sup> Operations 6K Ops/Hr with 6 NO on left and 6 NC on right
<b>Selector Switches</b>	250 x 10 <sup>3</sup> Operations 3K Ops/Hr with 2 NO on left and 2 NC on right
<b>Push-Pull Operators</b>	250 x 10 <sup>3</sup> Operations 3K Ops/Hr with 6 NO on left and 6 NC on right
<b>Environmental Specifications</b>	
<b>Operating Temperature</b>	10° to 140°F (-12° to 60°C)
<b>Storage Temperature</b>	-40° to 176°F (-40° to 80°C)
<b>Altitude</b>	6,562 ft. (2,000m)
<b>Humidity</b>	95% RH @ 60°C
<b>Terminals</b>	
<b>Contact Blocks</b>	#6-32 posi-drive saddle clamp type, 1 x 16 AWG to 2 x 14 AWG, 12 in-lbs max.
<b>Light Units</b>	#6-32 posi-drive saddle clamp type, 1 x 22 AWG to 2 x 14 AWG, 7 in-lbs max.

HT800 Standard Contact Blocks UL (NEMA) Rating				
Electrical Ratings Description/Function	Contact Type	Catalog Number	AC	DC
Standard Normally Open contact	NO	<b>HT8A</b>	A600	P600
Standard Normally Closed contact	NC	<b>HT8B</b>	A600	P600
Normally Open Early Make Contact will make circuit before standard NO contact. DC ratings do not apply.	NOEM	<b>HT8C</b>	A600	—
Normally Closed Late Break contact will open after standard NC contact. DC ratings do not apply.	NCLB	<b>HT8D</b>	A600	—
Logic level, low voltage NO contact. Gold plated contacts.	NO	<b>HT8E</b>	5V 1 mA (minimum) 28V 500 mA (maximum)	

UL (NEMA) A600 and P600 Ratings							
Description	Volts AC 50/60 Hz				Volts DC <sup>1</sup>		
	120	240	480	600	125	250	600
<b>Make and Emerg. Interrupting Capacity (Amp)</b>	60	30	15	12	1.1	0.55	0.2
<b>Normal Load Break (Amp)</b>	6	3	1.5	1.2	1.1	0.55	0.2
<b>Thermal Current (Amp)</b>	10	10	10	10	5	5	5
<b>Voltamperes</b>							
<b>Make and Emerg. Interrupting Capacity</b>	7200	7200	7200	7200	138 <sup>2</sup>	138 <sup>2</sup>	138 <sup>2</sup>
<b>Normal Load Break</b>	720	720	720	720	138	138	138

Note: 1: DC ratings do not apply to NOEM (Normally Open Early Make) and NCLB (Normally Closed Late Break) contact blocks HT8C and HT8D.

2: Maximum make or break volt-amperes at 300V or less

# HT800 30 mm Momentary Pushbuttons



HT8AAG



HT8ABR



HT8AEH

Contact Type	Button Color	Flush Head Momentary		Extended Head Momentary		Mushroom Head Momentary	
		Catalog Number	Price	Catalog Number	Price	Catalog Number	Price
<b>Operator Only, No Contacts</b>	Black	HT8AAH	<--->	HT8ABH	<--->	HT8AEH	<--->
	Red	HT8AAR	<--->	HT8ABR	<--->	HT8AER	<--->
	Green	HT8AAG	<--->	HT8ABG	<--->	HT8AEG	<--->
<b>1 N.O.</b>	Black	*HT8AAHA	<--->	*HT8ABHA	<--->	*HT8AEHA	<--->
	Red	*HT8AARA	<--->	*HT8ABRA	<--->	*HT8AERA	<--->
	Green	*HT8AAGA	<--->	*HT8ABGA	<--->	*HT8AEGA	<--->
<b>1 N.C.</b>	Black	*HT8AAHB	<--->	*HT8ABHB	<--->	*HT8AEHB	<--->
	Red	*HT8AARB	<--->	*HT8ABRB	<--->	*HT8AERB	<--->
	Green	*HT8AAGB	<--->	*HT8ABGB	<--->	*HT8AEGB	<--->
<b>1 N.O. and 1 N.C.</b>	Black	*HT8AAHAB	<--->	*HT8ABHAB	<--->	*HT8AEHAB	<--->
	Red	*HT8AARAB	<--->	*HT8ABRAB	<--->	*HT8AERAB	<--->
	Green	*HT8AAGAB	<--->	*HT8ABGAB	<--->	*HT8AEGAB	<--->
<b>2 N.O. and 2 N.C.</b>	Black	*HT8AAHF1Q1	<--->	*HT8ABHF1Q1	<--->	*HT8AEHF1Q1	<--->
	Red	*HT8AARF1Q1	<--->	*HT8ABRF1Q1	<--->	*HT8AERF1Q1	<--->
	Green	*HT8AAGF1Q1	<--->	*HT8ABGF1Q1	<--->	*HT8AEGF1Q1	<--->

**Notes:** A grounding kit is included with each operator or switch assembly.  
 Part numbers with an \* are kitted from individual components at AUTOMATIONDIRECT. The individual components are picked and shipped in the same shipping box. Final assembly of the individual components must be done by the customer.

## 30.5 mm Pushbutton Installation and Mounting Instructions

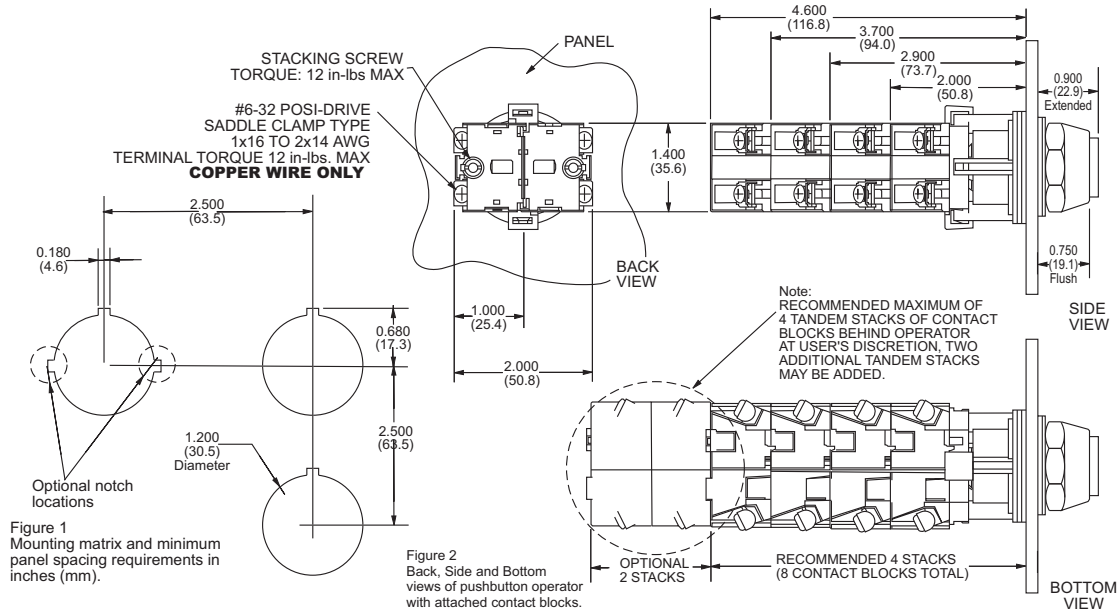

# HT800 30 mm Momentary Pushbuttons

## 30.5 mm Pushbutton Installation and Mounting Instructions

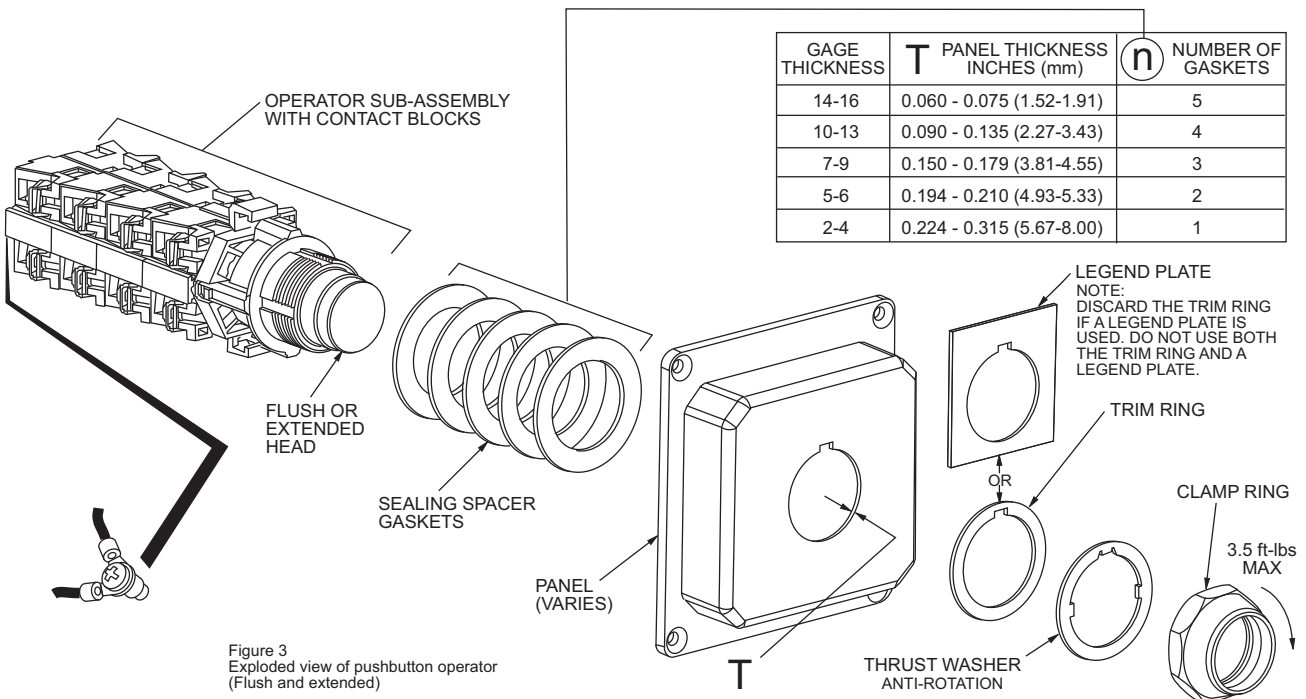
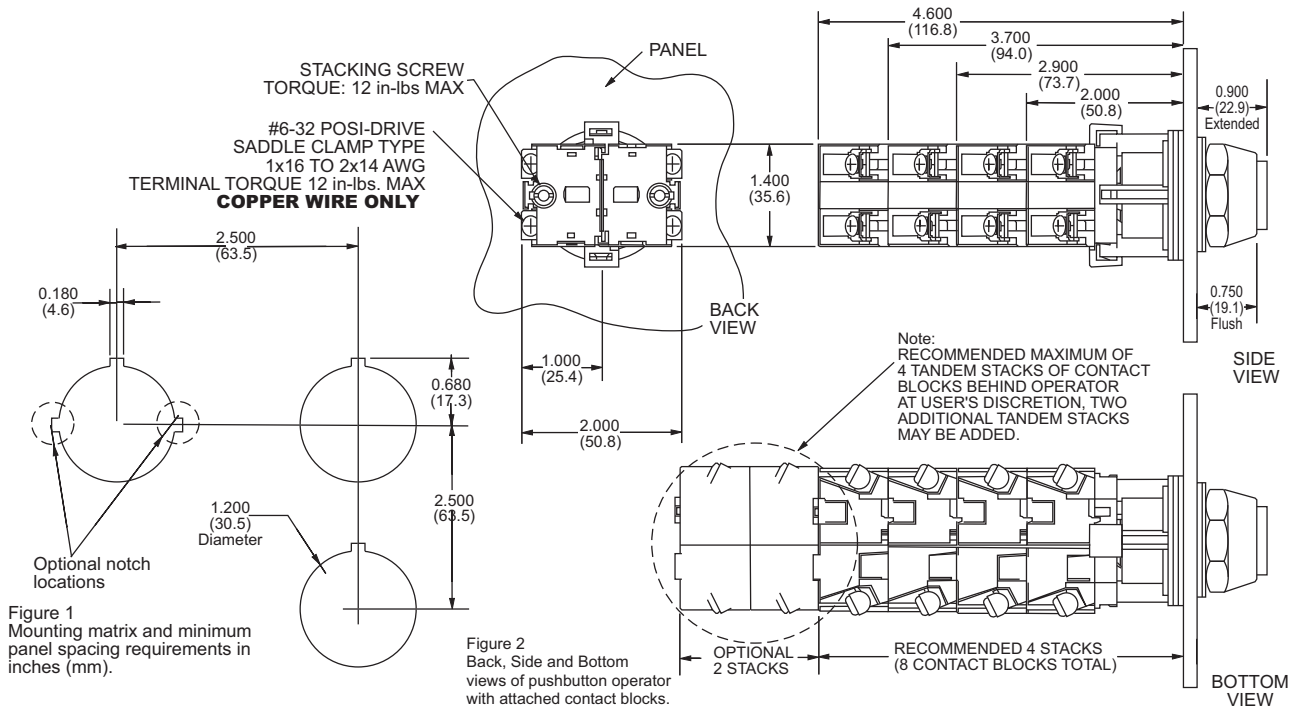

## Contact blocks



HT8A



HT8B

HT8 Series Contact Blocks		
Part Number	Description	Price
<b>HT8A</b>	Normally open contact block for HT8 series switches. NEMA Rated A600, P600 <sup>1</sup>	<--->
<b>HT8B</b>	Normally closed contact block for HT8 series switches. NEMA Rated A600, P600 <sup>1</sup>	<--->
<b>HT8C</b>	Early closing normally open contact block for HT8 series switches. NEMA Rated A600 <sup>1</sup>	<--->
<b>HT8D</b>	Late opening normally closed contact block for HT8 series switches. NEMA Rated A600 <sup>1</sup>	<--->
<b>HT8E</b>	Logic level normally open contact block for HT8 series switches. Gold plated contacts for reliable low energy switching. Power Rating: Min 1mA @ 5V; Max 500mA 28V.	<--->

**Notes:**

1. See page 25-6 for typical contact wiring diagram.
2. NEMA ICS 5-2000. For more information, refer to HT800 technical specifications on page 25-65, and Control Circuit Contact Electrical Ratings, page 25-66.

## Spare parts and tools



HT8WRENCH



HT8LAMPTOOL



109305



HT8BULBV3



HT8LEDYF3

HT8 Series Spare Parts and Tools		
Part Number	Description	Price
<b>HT8WRENCH</b>	Installation wrench for Cutler-Hammer HT8 series and E22 series pushbuttons, switches, and indicators	<--->
<b>HT8LAMPTOOL</b>	Bulb extraction tool for removing bulbs from switches, indicators and stacklights	<--->
<b>109305</b>	Knockout punch hole cutting tool for 30.5 mm mounting hole. Includes punch, die and draw stud	<--->
<b>HT8X1</b>	Spare anti-rotation ring for HT8 series. Included with each HT8 device. (not shown)	<--->
<b>HT8X2</b>	Spare trim ring for HT8 series. Included with each HT8 device. (not shown)	<--->
<b>HT8X3</b>	Spare sealing/spacing ring for HT8 series. Included with each HT8 device. (not shown)	<--->
<b>HT8GR1</b>	Spare grounding kit for HT8 series devices except non-PTT indicators. Included with each HT8 device. (not shown)	<--->
<b>HT8GR2</b>	Spare grounding kit for HT8 series non-PTT indicators. Included with each HT8 device. (not shown)	<--->
<b>HT8BULBV3</b>	24 volt incandescent bulb for HT8 illuminated devices. This is an extended bulb for enhanced illumination with HT8 devices. 50mA at 24 volts.	<--->
<b>HT8BULBV7</b>	120 volt incandescent bulb for HT8 illuminated devices. This is an extended bulb for enhanced illumination with HT8 devices. 19mA at 120 volts.	<--->
<b>HT8LEDRF3</b>	24 volt replacement LED bulb for HT800 30mm pushbuttons. Color: Red	<--->
<b>HT8LEDYF3</b>	24 volt replacement LED bulb for HT800 30mm pushbuttons. Color: Yellow	<--->
<b>HT8LEDGF3</b>	24 volt replacement LED bulb for HT800 30mm pushbuttons. Color: Green	<--->
<b>HT8LEDBF3</b>	24 volt replacement LED bulb for HT800 30mm pushbuttons. Color: Blue	<--->
<b>HT8LEDWF3</b>	24 volt replacement LED bulb for HT800 30mm pushbuttons. Color: White	<--->
<b>HT8LEDAF3</b>	24 volt replacement LED bulb for HT800 30mm pushbuttons. Color: Amber	<--->
<b>HT8LEDRF7</b>	120 volt replacement LED bulb for HT800 30mm pushbuttons. Color: Red	<--->
<b>HT8LEDYF7</b>	120 volt replacement LED bulb for HT800 30mm pushbuttons. Color: Yellow	<--->
<b>HT8LEDGF7</b>	120 volt replacement LED bulb for HT800 30mm pushbuttons. Color: Green	<--->
<b>HT8LEDBF7</b>	120 volt replacement LED bulb for HT800 30mm pushbuttons. Color: Blue	<--->
<b>HT8LEDWF7</b>	120 volt replacement LED bulb for HT800 30mm pushbuttons. Color: White	<--->
<b>HT8LEDAF7</b>	120 volt replacement LED bulb for HT800 30mm pushbuttons. Color: Amber	<--->

NOTE: LED modules have very low current draw and should not be used with triac output devices like PLC triac output modules.

# 30 mm Legend Plates

For Pushbutton Operators and Indicating Lights			
Legend	Color of Field	Catalog Number	Price
Clamp	Black	HT8SP90	<--->
Close	Black	HT8SP73	<--->
Down	Black	HT8SP74	<--->
Emergency Stop	Red	HT8SP13	<--->
Fast	Black	HT8SP75	<--->
Faster	Black	HT8SP87	<--->
Feeder On	Black	HT8SP94	<--->
Feeder Off	Black	HT8SP95	<--->
Forward	Black	HT8SP15	<--->
High	Black	HT8SP16	<--->
In	Black	HT8SP17	<--->
Inch	Black	HT8SP18	<--->
Jog	Black	HT8SP19	<--->
Jog Forward	Black	HT8SP20	<--->
Jog Reverse	Black	HT8SP21	<--->
Low	Black	HT8SP22	<--->
Lower	Black	HT8SP23	<--->
Lube-fail	Black	HT8SP92	<--->
Motor Run	Black	HT8SP81	<--->
Motor Stop	Black	HT8SP82	<--->
Off	Red	HT8SP24	<--->
On	Black	HT8SP25	<--->
Open	Black	HT8SP26	<--->
Out	Black	HT8SP27	<--->
Power On	Black	HT8SP80	<--->
Raise	Black	HT8SP28	<--->
Ready	Black	HT8SP86	<--->
Reset	Black	HT8SP29	<--->
Reverse	Black	HT8SP30	<--->
Run	Black	HT8SP31	<--->
Safe	Black	HT8SP85	<--->
Slow	Black	HT8SP32	<--->
Slower	Black	HT8SP88	<--->
Start	Black	HT8SP33	<--->
Stop	Red	HT8SP34	<--->
Test	Black	HT8SP83	<--->
Transfer	Black	HT8SP93	<--->
Trip	Black	HT8SP84	<--->
Unclamp	Black	HT8SP91	<--->
Up	Black	HT8SP35	<--->

*\*Note: Dimensions: 1.77" (45mm) x1.77" (45mm)*



For Selector Switch Operators/ Two-Position			
Legend	Color of Field	Catalog Number	Price
Forward Reverse	Black	HT8SP38	<--->
Hand Auto	Black	HT8SP39	<--->
High Low	Black	HT8SP40	<--->
Jog Run	Black	HT8SP41	<--->
Manual Auto	Black	HT8SP67	<--->
Off On	Black	HT8SP42	<--->
Open Close	Black	HT8SP43	<--->
Run Jog	Black	HT8SP44	<--->
Safe Run	Black	HT8SP45	<--->
Start Jog	Black	HT8SP46	<--->
Start Stop	Black	HT8SP47	<--->
Up Down	Black	HT8SP48	<--->

For Selector Switch Operators/ Three-Position			
Legend	Color of Field	Catalog Number	Price
Auto Off Hand	Black	HT8SP49	<--->
For. Off Rev	Black	HT8SP50	<--->
For. Safe Rev.	Black	HT8SP69	<--->
Hand Off Auto	Black	HT8SP51	<--->
Man. Off Auto	Black	HT8SP68	<--->
Open Off Close	Black	HT8SP53	<--->
Run Safe Jog	Black	HT8SP70	<--->
Up Off Down	Black	HT8SP54	<--->
On Stop Safe	Black	HT8SP71	<--->

For PUSH/PULL Units			
Legend 3/32" lettering	Color of Field	Catalog Number	Price
ON/OFF	Black	HT8PP5	<--->
OPEN/CLOSE	Black	HT8PP8	<--->
UP/DOWN	Black	HT8PP11	<--->

NOTE: All 30 mm legend plates are plastic.

Square Blank Plastic Legend Plates			
Lettering	Color of Field	Catalog Number	Price
Black	White/Silver	HT8SP76	<--->
White	Red/Black	HT8SP77	<--->

Round Plastic Legend Plates			
Legend	Color of Field	Catalog Number	Price
ESTOP	Yellow	HT8RP79	<--->

NOTE: 70 mm / 2-3/4" diameter