

# CE15 Contactor Specifications

45 mm Cutler-Hammer CE15 Contactor Specifications								
Contactor Model			CE15AN	CE15BN	CE15CN	CE15DN	CE15EN	CE15FN
<b>Insulation Voltage</b>	AC	(V)	690 Volts AC					
<b>Ampere Rating</b>	Max. UL Current (AC3) <small>note 1</small>	(A)	7	10	12	18	25	32
	AC1 Thermal Current (600V) <small>note 2</small>	(A)	20	20	20	32	32	32
<b>Maximum Power (hp) of Three-Phase Motors</b>	200V	(hp)	1.5	2	3	5	5	7.5
	230/240V	(hp)	1.5	2	3	5	7.5	10
	460/480V	(hp)	3	5	7.5	10	15	20
	575V	(hp)	5	7.5	10	15	20	25
<b>Maximum Power (hp) of Single-Phase Motors</b>	115V	(hp)	0.25	0.5	0.5	1	2	2
	230/240V	(hp)	0.5	1	2	3	3	5
<b>Maximum Power (kw) of Three-Phase Motors AC3 Category</b> <small>note 1</small>	230/240V	(kW)	1.1	1.5	2.2	4	5.5	7.5
	415/440V	(kW)	2.2	4	5.5	7.5	11	15
	500/550V	(kW)	2.2	4	5.5	7.5	11	15
	500V	(kW)	4	5.5	7.5	11	15	18.5
	600V	(kW)	1.5	2.2	4	5.5	7.5	10
Auxiliary Contacts Electrical Capacity			A600 <small>note 4</small>					
SCCR			5kA					
Coil Voltage Operating Limits			A.C. Pick-Up 85-110% Rated Control Voltage / A.C. Drop-Out 20-75% Rated Control Voltage					
Average Coil Power Requirements / Coil current (A) = VA/Coil Voltage			A.C. Pick-Up (VA) 80-100 / A.C. Sealed (VA) 9-12					
Power Factor			Pick-Up .65 / Sealed .35					
Coil Operating Time at Rated Coil Voltage			Pick-Up (ms) 10-25 / Drop-Out (ms) 6-18					
Maximum Operating Frequency (No-Load Operation)			3000 Operations / Hour					
Mechanical Durability			10,000,000 Operations					
Electrical Durability			1,000,000 Operations					
Operating Ambient Temperature			-25° to +55°C					
Electrical Protection Degree			IP20 (IP10 for GH15ET and GH15FT)					
Mounting			Screw or 35mm DIN Rail					
<b>Wire Sizes</b>	Line / Load		#10 - #14 AWG stranded recommended			#14 - #8 stranded recommended		
	Control & Auxiliary Contacts		#12 - #14 AWG (stranded recommended)					
<b>Line/Load Tighting Torque</b>	Nm (Inch Pounds)		7	7	7	15	15	15

**Notes**

- AC3 type loads consist of squirrel cage three phase motors.
- AC1 non-inductive or slightly inductive loads. Typically resistive loads (i.e. furnaces, ovens, etc.)
- Type 2 coordination is a protection category for IEC 60947-4-1. Section 8.2.5.1 specifies that Type 2 coordination requires that, under short circuit conditions, the contactor or starter shall cause no danger to persons or installations and shall be suitable for further use. The risk of minor contact welding is possible.
- NEMA ICS 5-2000. For more information, refer to Control Circuit Contact Electrical Ratings, page 17-77.

Cutler-Hammer CE15 Series Contactor Part Numbers									
IEC FRAME SIZE	Cutler-Hammer Contactor Model	Part Number	Price	Number of Contacts		Coil Voltage and Frequency	Additional Contacts		
				Main	Auxiliary Contacts Included		Maximum Contact Block Arrangement	Type of Additional Contact Block	
					N.O.				N.C.
45 mm	CE15AN	CE15AN4AB	<-->	4			Up to two auxiliary contact blocks may be added to CE15 contactors (one per side).	Side mount C320KGS3: 1 N.O. / 1 N.C. C320KGS1: 1 N.O. / 1 N.C.	
		CE15AN4BB	<-->	4					
	CE15BN	CE15BN4AB	<-->	4					
		CE15BN4BB	<-->	4					
	CE15CN	CE15CN4AB	<-->	4					
		CE15CN4BB	<-->	4					
	CE15DN	CE15DNS3AB	<-->	3	1				
		CE15DNS3BB	<-->	3	1				
	CE15EN	CE15ENS3AB	<-->	3	1				
		CE15ENS3BB	<-->	3	1				
	CE15FN	CE15FNS3AB	<-->	3	1				
		CE15FNS3BB	<-->	3	1				

Note: Holding circuit contact(s) supplied standard: a N.O. auxiliary contact block is mounted on the right-hand side. (On Sizes A-C, contact occupies fourth power pole position - no increase in width.)



# Motor Control Dimensions

Size and Dimensions (Inches)										
Product	IEC Size	Contactor Type								Ship Weight in Pounds
		Wide			High			Mounting		
		A	B	C	D	E	E1	F	G	
Starters	A-F	1.80	5.86	3.28	1.36	5.19	5.39	-	54	1.75
Contactors	A-C	1.80	2.96	3.26	1.36	1.96	-	-	54	1.3
Contactors	D-F	1.80	2.96	3.26	1.36	1.96	-	-	54	1.4
Overload Relays	32 Amp	1.77	4.13	3.69	1.36	3.74	-	-	-	0.8

## IEC contactor sizes A-F, CE15

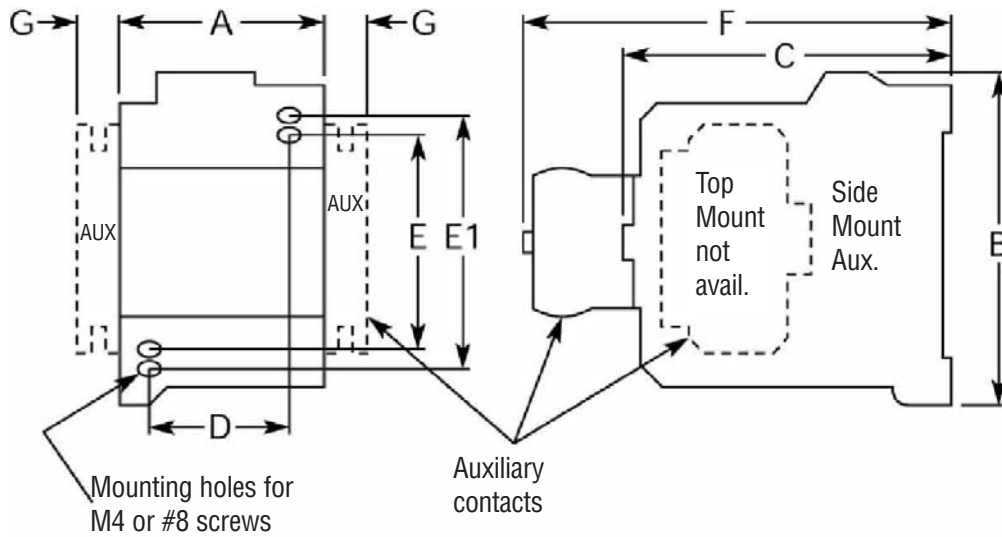

## IEC starter sizes A-F, AE16

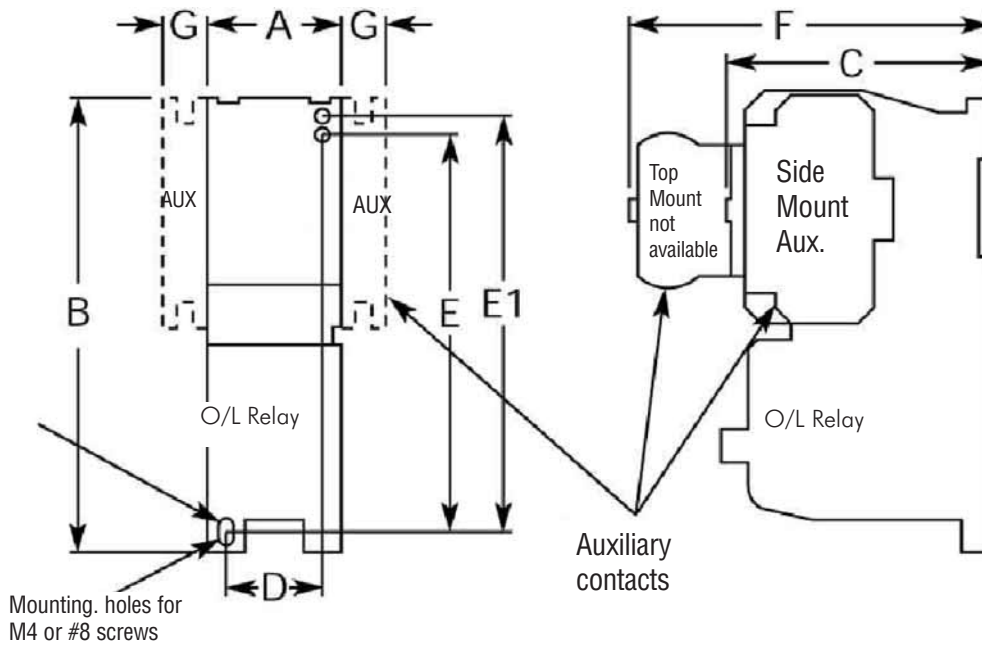



- Company Information
- Systems Overview
- Programmable Controllers
- Field I/O
- Software
- C-more & other HMI
- Drives
- Soft Starters
- Motors & Gearbox
- Steppers/ Servos
- Motor Controls**
- Proximity Sensors
- Photo Sensors
- Limit Switches
- Encoders
- Current Sensors
- Pressure Sensors
- Temperature Sensors
- Pushbuttons/ Lights
- Process
- Relays/ Timers
- Comm.
- Terminal Blocks & Wiring
- Power
- Circuit Protection
- Enclosures
- Tools
- Pneumatics
- Safety
- Appendix
- Product Index
- Part # Index

# Electrical Ratings Charts

## Motor Current Ratings

Full Load Ampere (FLA) Rating for AC Induction Motors							
Motor HP	115 VAC		200 VAC		230 VAC		460 VAC
	1-Phase (A)	3-Phase (A)	1-Phase (A)	3-Phase (A)	1-Phase (A)	3-Phase (A)	3-Phase (A)
1/10	3.0	---	---	---	1.5	---	---
1/8	3.8	---	---	---	1.9	---	---
1/6	4.4	---	2.5	---	2.2	---	---
1/4	5.8	---	3.3	---	2.9	---	---
1/3	7.2	---	4.1	---	3.6	---	---
1/2	9.8	4.4	5.6	2.5	4.9	2.2	1.1
3/4	13.8	6.4	7.9	3.7	6.9	3.2	1.6
1	16.0	8.4	9.2	4.8	8.0	4.2	2.1
1 1/2	20.0	12.0	11.5	6.9	10	6.0	3.0
2	24.0	13.6	13.8	7.8	12	6.8	3.4
3	34.0	19.2	19.6	11.0	17	9.6	4.8
5	56.0	30.4	32.2	17.5	28	15.2	7.6
7 1/2	80.0	44.0	46.0	25.3	40	22	11
10	100.0	56.0	57.5	32.2	50	28	14
15	---	84.0	---	48.3	---	42	21
20	---	108.0	---	62.1	---	54	27
25	---	136.0	---	78.2	---	68	34
30	---	160.0	---	92	---	80	40
40	---	208.0	---	120	---	104	52
50	---	260.0	---	150	---	130	65
60	---	---	---	177	---	154	77
75	---	---	---	221	---	192	96
100	---	---	---	285	---	248	124

The motor currents are approximate and not guaranteed to be accurate. This chart is provided as a guideline only. Values were extrapolated from NEC Tables 430-148 and 430-150. Motor currents should be taken from the motor's nameplate. It is the user's responsibility to properly size their motor control devices.

## Control Circuit Contact Electrical Ratings

NEMA Mechanical Switching Ratings and Test Values for DC Control Circuit Contacts					
Contact Rating Designation	Thermal Continuous Test Current (A)	Maximum Make or Break DC Current (A)			Voltamperes
		125 Volts	250 Volts	301 to 600 Volts	
P300	5.0	1.1	0.55	---	138
P600	5.0	1.1	0.55	0.20	138
Q300	2.5	0.55	0.27	---	69
Q600	2.5	0.55	0.27	0.10	69
R300	1.0	0.22	0.11	---	28

This chart is provided as a guideline only, and the ratings and values are not guaranteed to be accurate. It is the users' responsibility to properly size their control circuit devices. The chart values are from NEMA Standard ICS 5-2000, Table 1-4-2.

NEMA Mechanical Switching Ratings and Test Values for AC Control Circuit Contacts											
Contact Rating Designation	Thermal Continuous Test Current (A)	Maximum AC Current, 50/60Hz (A)								Voltamperes	
		120 Volts		240 Volts		480 Volts		600 Volts			
		Make	Break	Make	Break	Make	Break	Make	Break	Make	Break
A300	10	60	6.00	30	3.00	---	---	---	---	7200	720
A600	10	60	6.00	30	3.00	15	1.50	12	1.20	7200	720
B300	5	30	3.00	15	1.50	---	---	---	---	3600	360
B600	5	30	3.00	15	1.50	7.5	0.75	6	0.60	3600	360
C600	2.5	15	1.5	7.5	0.75	3.75	0.375	3.00	0.30	1800	180

This chart is provided as a guideline only, and the ratings and values are not guaranteed to be accurate. It is the users' responsibility to properly size their control circuit devices. The chart values are from NEMA Standard ICS 5-2000, Table 1-4-1.

# IEC Utilization Categories

IEC Utilization Categories for Low Voltage Switchgear and Control Gear				
Current	Category	Typical Applications	Relevant IEC Product Standard (3)	
AC	AC-1	Non inductive or slightly inductive loads, resistance furnaces, heaters	60947-4	
	AC-2	Slip-ring motors: switching off		
	AC-3	Squirrel-cage motors: starting, switching off motors during running most typical industrial application		
	AC-4	Squirrel-cage motors: starting, plugging (1), inching (2)		
	AC-5a	Switching of electric discharge lamps		
	AC-5b	Switching of incandescent lamps		
	AC-6a	Switching of transformers		
	AC-6b	Switching of capacitor banks		
	AC-7a	Slightly inductive load in household appliances: mixers, blenders		
	AC-7b	Motor-loads for household applications: fans, central vacuum		
	AC-8a	Hermetic refrigerant compressor motor control with manual resetting overloads		
	AC-8b	Hermetic refrigerant compressor motor control with automatic resetting overloads		
	AC-12	Control of resistive loads and solid state loads with opto-coupler isolation		60947-5
	AC-13	Control of solid state loads with transformer isolation		
	AC-14	Control of small electromagnetic loads		
AC and DC	AC-15	Control of AC electromagnetic loads	60947-3	
	AC-20	Connecting and disconnecting under no-load conditions		
	AC-21	Switching of resistive loads, including moderate loads		
	AC-22	Switching of mixed resistive and inductive loads, including moderate overloads		
	AC-23	Switching of motor loads or other highly inductive loads		
	A	Protection of circuits, with no rated short-time withstand current		60947-2
	B	Protection of circuits, with a rated short-time withstand current		
DC	DC-1	Non-Inductive or slightly inductive loads, resistance furnaces, heaters	60947-4	
	DC-3	Shunt-motors, starting, plugging (1), inching (2), dynamic breaking of motors		
	DC-5	Series-motors, starting, plugging (1), inching (2), dynamic breaking of motors		
	DC-6	Switching of incandescent lamps		
	DC-12	Control of resistive loads and solid state loads with opto-coupler isolation	60947-5	
	DC-13	Control of DC electromagnetics		
	DC-14	Control of D.C. electromagnetic loads having economy resistors in the circuit		
	DC-20	Connecting and disconnecting under no-load conditions	60947-3	
	DC-21	Switching of resistive loads, including moderate overloads		
	DC-22	Switching of mixed resistive and inductive loads, including moderate overloads (i.e. shunt motors)		
DC-23	Switching of highly inductive loads (i.e. series motors)			

(1) **Plugging** - Stopping a motor rapidly by reversing the primary power connections.

(2) **Inching** - Energizing a motor repeatedly for short periods to obtain small incremental movements.

(3) IEC Standards must be purchased from the International Electrotechnical Commission