

# Edison Power Distribution Blocks



## Short-Circuit Current Rated Power Distribution Blocks

We offer distinctly different styles of short-circuit current rated Power Distribution Blocks and Terminal Blocks to match different application needs. The different features are:

- 1) Enclosed style or Open style
- 2) UL1953 Listed power distribution blocks or UL1059 Recognized terminal blocks, that have different minimum spacing requirements.

The table below can assist in the selection of the correct series for your application requirements.

### Why are these important?

Assembly short-circuit current ratings (SCCRs) are now required in the 2005 NEC® and UL508A Listed industrial control panels.

Marking the SCCR on:

- Industrial Control Panels (NEC®409.110)
- Industrial Machinery Electrical Panels (NEC®670.3(A))
- HVAC equipment (NEC®440.4(B))

The above sections are now required by the National Electrical Code. Power Distribution Blocks or Terminal Blocks not marked with an SCCR are typically one of the weakest links and may limit an assembly to no more than 10 kA SCCR per Table SB4.1 UL508A. The EPDB series and HPB series Power Distribution Blocks have increased spacing required where used in feeder circuits in equipment listed to UL508A. The PB series UL1059 Terminal Blocks must be evaluated for proper spacing. Also, for building wiring systems, the EPDB series and HPB series power distribution blocks can be used to meet the 2005 NEC® requirements in section 376.56(B) for power distribution blocks in wireways.

Edison Power Distribution Blocks Selection Guide*								
Series	UL	† Enclosed	High SCCR**	Spacing*** 1" Air 2" Surface	Industrial Control Panels UL 508A Branch Circuit	Industrial Control Panels UL 508A Feeder Circuit	HVAC UL 1995	Wireways NEC® 376.56(B) (Requires UL 1953)
EPDB	UL 1953 Listed Power Distribution Blocks	Yes	Yes	Yes	Yes	Yes	Yes	Yes
HPB	UL 1953 Listed Power Distribution Blocks	No****	Yes	Yes	Yes	Yes	Yes	Yes (with optional cover)
PB	UL 1059 Recognized Terminal Blocks	No****	Yes	No*****	Yes	No*****	Yes	No

† IP-20 finger-safe under specific conditions.

\*Refer to specific UL standards and NEC sections for a complete application guide.

\*\*When protected by proper fuse class with maximum ampere rating specified or smaller. This does not apply to PB40, PB51 and PB71 series.

\*\*\*See Minimum Space Requirements for Equipment table below.

\*\*\*\*Optional covers are available. They are not IP-20 rated, but do provide additional protection against direct contact with Live Parts.

\*\*\*\*\*Exception: Yes, if single pole units installed with proper spacings.

Minimum Space Requirements for Equipment			
UL Standard	Spacing Between Live Parts of Opposite Polarity		Spacing Between Live Parts and Grounded Parts or Enclosures, Through Air and Over Surface @ 600V
	Through Air @ 600V	Over Surface @ 600V	
508A Feeder Circuits, Table 10.2	1"	2"	1"
508A Branch Circuits, Table 10.1	3/8"	1/2"	1/2"
UL 1995 HVAC	3/8"	1/2"	1/2"

Note: Refer to specific UL standards for complete spacing details.

# EPDB Series Edison Finger-Safe Power Distribution Blocks

## Finger-safe distribution blocks

Use Finger-safe Power Distribution Blocks to manage your power distribution needs, from splitting primary power circuits into a variety of branch circuits to providing a fixed junction tap-off point. The modular design allows the end user to select and configure the number of poles required by each application. These blocks are engineered to allow copper conductors and maintain an SCCR rating of 200kA. These features make these blocks the perfect solution to today's power circuit wiring requirements.

## Features

- Fully enclosed block for touch-safe isolation of live parts
- IP20 rating under specific conditions
- Integrated DIN-rail or direct panel mounting. (Panel mount only for EPDB306 and EPDB702)
- Captive termination screws cannot be lost
- Used in UL508A panels for both feeder and branch circuit applications
- Suitable for both factory and field wiring
- Tin-plated aluminum connectors suitable for copper conductors

## Ratings

- Ampere ratings from 175 Amps to 760
- 600 VAC or VDC
- Short Circuit Current Rating (SCCR) 200kA with proper fusing
- Flammability: UL 94V0

## Agency Approvals

- UL 1953 Listed - File E256146, Guide QPQS
- CSA Certified - Class 6228-01, File 700490
- CE component IEC 60947-1
- IEC-60529, IP20 (Finger-Safe)  
See table for specific conditions.

Finger-safe Power Distribution Blocks Selection Table							
Series	Part Number	Amps	Description	SCCR Rtg	Pcs/Pkg	Wt.	Price
Finger-safe (EPDB)	EPDB101	175 max	1 pole distribution block, 1 in/1 out	200 kA	1	3.4 oz.	<--->
	EPDB104	175 max	1 pole distribution block, 1 in/4 out	200 kA	1	4.2 oz.	<--->
	EPDB301	310 max	1 pole distribution block, 1 in/1 out	200 kA	1	8.1 oz.	<--->
	EPDB306	380 max	1 pole distribution block, 1 in/6 out	200 kA	1	9.1 oz.	<--->
	EPDB512	570 max	1 pole distribution block, 2 in/12 out	200 kA	1	12.5 oz.	<--->
	EPDB702	760 max	1 pole distribution block, 2 in/2 out	200 kA	1	16.4 oz.	<--->
Accessory	DN-EB35*	-	End bracket	-	50	1.87 lb.	<--->

\*Note: DIN-rail anchors are required on block or blocks. Anchors must be used to prevent damage to the plastic housing when tightening terminals.

Finger-safe Power Distribution Block General Specifications	
Wire Type	75°C*, Cu
Voltage	600 VAC or VDC maximum (UL 1953), 690 VAC/VDC (IEC)
Operating Temperature	-10°C to 60°C (14°F to 140°F)
Storage Temperature	-20°C to 60°C (-4°F to 140°F)
Mounting	35mm DIN rail (DN-R35S1) or surface mount.
*Note: Amp Rating is based on NEC table 310.16 for 75°C copper wire.	



# EPDB Series Edison Finger-Safe Power Distribution Blocks Specifications

Edison Finger-Safe Power Distribution Blocks Wire and Torque Range Specifications								
Part Number	Line				Load			
	CU Wire Range	Torque Lb-in (Nm)	Trim Length in (mm)	Hex Key	CU Wire Range	Torque Lb-in (Nm)	Trim Length in (mm)	Hex Key
EPDB101	2/0 to 8 AWG, 70 to 10 mm <sup>2</sup>	110 [12.4]	0.850 [21.6]	3/16"	2/0 to 8 AWG, 70 to 10 mm <sup>2</sup>	110 [12.4]	0.970 [24.6]	3/16"
EPDB104	2/0 to 8 AWG, 70 to 10 mm <sup>2</sup>	120 [13.6]	0.750 [19.0]	3/16"	4 to 12 AWG, 25 to 16 mm <sup>2</sup>	35 [4.0]	0.550 [14.0] top row, 0.850 [21.6] bottom row	1/8"
					8 AWG, 10 mm <sup>2</sup>	25 [2.8]		
					10 to 14 AWG, 6 to 2.5 mm <sup>2</sup>	20 [2.3]		
EPDB301	350 kcmil to 6 AWG, 185 to 16 mm <sup>2</sup>	275 [31.1]	1.350 [34.3]	5/16"	350 Kcmil to 6 AWG, 185 to 16 mm <sup>2</sup>	275 [31.1]	1.250 [31.8]	5/16"
EPDB306	500 kcmil to 6 AWG, 240 to 16 mm <sup>2</sup>	500 [56.5]	1.250 [31.8]	3/8"	2 to 3 AWG, 35 mm <sup>2</sup>	50 [5.7]	0.590 [15.0] top row 1.200 [30.5] bottom row	1/8"
					4 to 6 AWG, 25 to 16 mm <sup>2</sup>	45 [5.1]		
					8 AWG, 10 mm <sup>2</sup>	40 [4.5]		
					10 to 14 AWG, 6 to 2.5 mm <sup>2</sup>	35 [4.0]		
EPDB512	300 kcmil to 4 AWG, 150 to 25mm <sup>2</sup>	275 [31.1]	1.15 [29.2] top row 1.400 [35.6] bottom row	1/4"	4 to 6 AWG, 25 to 16 mm <sup>2</sup>	35 [4.0]	0.550 [14.0] top row, 1.00 [25.4] middle row, 1.220 [31.0] bottom row	1/8"
					8 AWG, 10 mm <sup>2</sup>	25 [2.8]		
					10 to 14 AWG, 6 to 2.5 mm <sup>2</sup>	20 [2.3]		
EPDB702	500 kcmil to 6 AWG, 240 to 16 mm <sup>2</sup>	500 [56.5]	1.250 [31.8]	3/8"	500 kcmil to 6 AWG, 240 to 16 mm <sup>2</sup>	500 [56.5]	1.250 [31.8]	3/8"

Short-Circuit Current Rating Data										
Part Number (All Single Pole)	Capacity*	Line			Load		Maximum Fuse Class and Amps***			
		Openings per Pole	Wire Range (copper only)	openings per Pole	Wire Range (copper only)	Class J(JDL)	Class T (A3T/A6T)	Class RK1 (LENRK/LESRK)	Class RK5 (ECNR/ECSR)	SCCR Rating
EPDB101	175A	1	2/0 to 8 AWG 70 to 10 mm <sup>2</sup>	1	2/0 to 8 AWG 70 to 10 mm <sup>2</sup>	200	200	100	60	200 kA
EPDB104	175A	1	2/0 to 8 AWG 70 to 10 mm <sup>2</sup>	4	4 to 6 AWG 25 to 16 mm <sup>2</sup>	200	200	100	60	200 kA
					4 to 14 AWG 25 to 2.5 mm <sup>2</sup>	175	175	100	60	100 kA
						200	200	100	60	50 kA
EPDB301	310A	1	350 kcmil to 6 AWG 185 to 16 mm <sup>2</sup>	1	350 kcmil to 6 AWG 150 to 16 mm <sup>2</sup>	400	400	200	100	200 kA
EPDB306	380A	1	500 kcmil to 6 AWG 240 to 16 mm <sup>2</sup>	6	2 to 6 AWG 35 to 16 mm <sup>2</sup>	400	400	200	100	200 kA
					2 to 14 AWG 35 to 2.5 mm <sup>2</sup>	200	200	100	30	50 kA
						175	175	100	30	100 kA
EPDB512	570A	2	300 kcmil 150 mm <sup>2</sup>	12	4 to 8 AWG 25 to 10 mm <sup>2</sup>	600	600	400	200	200 kA
			300 kcmil to 4 AWG 150 to 12 mm <sup>2</sup>		4 AWG 25 mm <sup>2</sup>	600	600	400	200	50 kA
					4 to 14 AWG 25 to 2.5 mm <sup>2</sup>	200	200	100	30	50 kA
EPDB702	760A	2	500 kcmil 240 mm <sup>2</sup>	2	500 kcmil 240 mm <sup>2</sup>	600	800**	600	400	200 kA
			500 kcmil to 6 AWG 240 to 16 mm <sup>2</sup>		600	800**	600	600	100 kA	
					500 kcmil to 6 AWG 240 to 16 mm <sup>2</sup>	600	600	400	200	100 kA

\*Amp ratings are based on NEC® Table 310.16 for 75°C copper wire and UL508A Table 28.1.

\*\*Class L 800A or less fuses are suitable for this particular SCCR case.

\*\*\*Class G 60A or less, or Class CC 30A or less fuses are suitable for all SCCRs in this table.

# EPDB Series Edison Finger-Safe Power Distribution Blocks Dimensions

Edison Finger-Safe Power Distribution Blocks Dimensions (in[mm])								
Part Number	Width	Length	Height	D	E	F	G	H
	A	B	C					
EPDB101	1.03 [26.2]	3.55 [90.2]	2.15 [54.6]	3.37 [85.6]	2.90 [73.7]	0.2 [5.1]	0.2 [5.1]	N/A
EPDB104	1.03 [26.2]	3.55 [90.2]	2.15 [54.6]	3.37 [85.6]	2.90 [73.7]	0.2 [5.1]	0.2 [5.1]	N/A
EPDB301	1.54 [39.1]	4.62 [117.3]	2.87 [72.9]	4.44 [112.8]	3.78 [96.0]	0.2 [5.1]	0.24 [6.1]	N/A
EPDB306	1.54 [39.1]	4.62 [117.3]	2.87 [72.9]	4.44 [112.8]	3.78 [96.0]	0.2 [5.1]	0.24 [6.1]	N/A
EPDB512	1.86 [47.2]	4.65 [118.1]	2.95 [74.9]	4.47 [113.5]	3.81 [96.8]	0.2 [5.1]	0.24 [6.1]	N/A
EPDB702	2.56 [65.0]	4.65 [118.1]	3.17 [80.5]	4.47 [113.5]	3.81 [96.8]	0.2 [5.1]	0.24 [6.1]	1.81 [46.0]

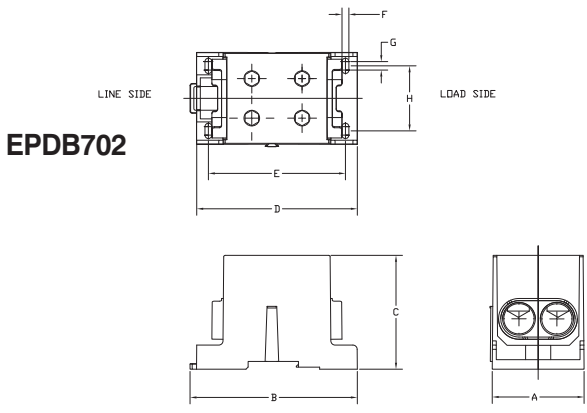
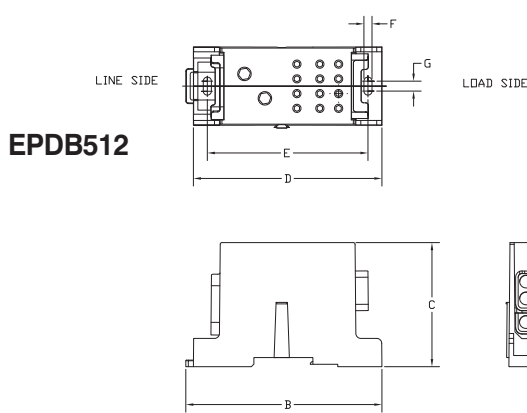
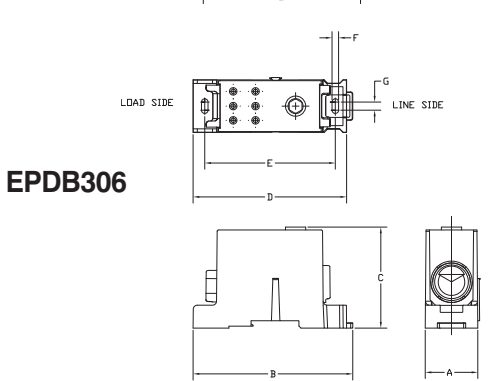
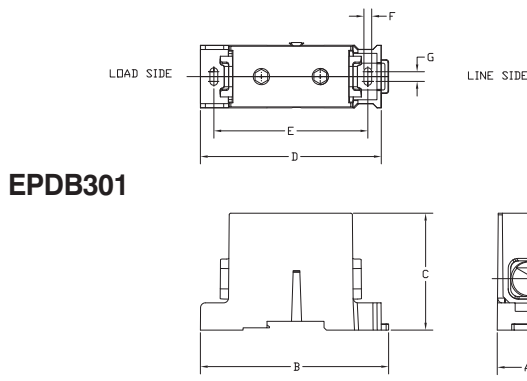
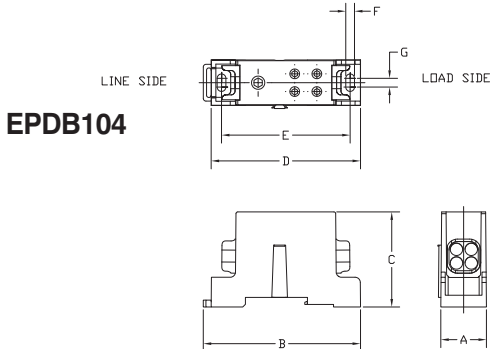
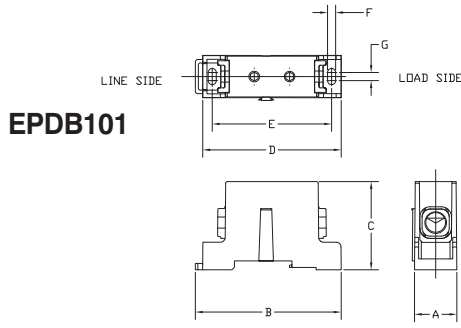

Part Number	Minimum Enclosure Size in(mm)*
EPDB101	16 x 16 x 6.75 [406.4 x 406.4 x 171.45]
EPDB104	16 x 16 x 6.75 [406.4 x 406.4 x 171.45]
EPDB301	36 x 30 x 12.63 [914.4 x 762 x 320.80]
EPDB306	24 x 20 x 6.75 [609.6 x 508 x 171.45]
EPDB512	24 x 20 x 6.75 [609.6 x 508 x 171.45]
EPDB702	36 x 30 x 12.63 [914.4 x 762 x 320.80]

\*Note: Terminal block SCCR determined based on testing in minimum-size enclosure

Wire Connector Hole Diameter		
Part Number	Line in (mm)	Load in (mm)
EPDB101	0.450 [11.43]	0.450 [11.43]
EPDB104	0.450 [11.43]	0.246 [6.25]
EPDB301	0.720 [18.29]	0.720 [18.29]
EPDB306	0.870 [22.10]	0.314 [7.98]
EPDB512	0.687 [17.45]	0.265 [6.73]
EPDB702	0.875 [22.23]	0.875 [22.23]

# EPDB Series Edison Finger-Safe Power Distribution Blocks IP-20 Finger-safe Status Requirements

Specific Conditions to Achieve IP-20 Finger-Safe Status for EPDB Series								
Part Number	Line				Load			
	Trim Length in [mm]	Installed Wire	IP-20		Trim Length in [mm]	Installed Wire	IP-20	
			Conductor Openings	Screw Opening			Conductor Openings	Screw Opening
<b>EPDB101</b>	0.850 [21.6]	2/0 to 8 AWG 70 to 10mm <sup>2</sup>	Yes	Yes	0.970 [24.6]	2/0 to 8 AWG 70 to 10mm <sup>2</sup>	Yes	Yes
<b>EPDB104</b>	0.750 [19.0]	2/0 to 8 AWG 70 to 10mm <sup>2</sup>	Yes	Yes	0.550 [14.0] top row, 0.850 [21.6] bottom row	4 to 14 AWG 25 to 2.5mm <sup>2</sup>	Yes	Yes
						screws fully opened	N/A	Yes
						no wire in hole	No	N/A
<b>EPDB301</b>	1.350 [34.3]	350 Kcmil to 2/0 AWG 185 to 70mm <sup>2</sup>	Yes	Yes	1.250 [31.8]	350 Kcmil to 2/0 AWG 185 to 70mm <sup>2</sup>	Yes	Yes
		1/0 to 6 AWG 50 to 16mm <sup>2</sup>	No	Yes		1/0 to 6 AWG 50 to 16mm <sup>2</sup>	No	Yes
<b>EPDB306</b>	1.250 [31.8]	500 to 250 Kcmil 240 to 150mm <sup>2</sup>	Yes	Yes	0.590 [15.0] top row, 1.200 [30.5] bottom row	2 to 14 AWG 35 to 2.5mm <sup>2</sup>	Yes	Yes
		4/0 to 6 AWG 120 to 16mm <sup>2</sup>	No	Yes		screws fully opened	N/A	Yes
		N/A	N/A	N/A		no wire in hole	No	N/A
<b>EPDB512</b>	1.15 [29.2] top row, 1.400 [35.6] bottom row	300 Kcmil to 4/0 AWG 150 to 120mm <sup>2</sup>	Yes	Yes	0.550 [14.0] top row 1.00 [25.4] middle row 1.220 [31.0] bottom row	4 to 14 AWG 25 to 2.5mm <sup>2</sup>	Yes	Yes
		3/0 to 4 AWG 95 to 25mm <sup>2</sup>	No	Yes		screws fully opened	N/A	Yes
		screws fully opened	N/A	No		no wire in hole	Yes	N/A
		no wire in hole	No	N/A				
<b>EPDB702</b>	1.250 [31.8]	500 to 350 Kcmil 240 to 185mm <sup>2</sup>	Yes	Yes	1.250 [31.8]	500 to 350 Kcmil 240 to 185mm <sup>2</sup>	Yes	Yes
		300 Kcmil to 6 AWG 150 to 16mm <sup>2</sup>	No	Yes		300 Kcmil to 6 AWG 150 to 16mm <sup>2</sup>	No	Yes
		screws fully opened	N/A	No		screws fully opened	N/A	No
		no wire in hole	No	N/A		no wire in hole	No	N/A