

Edison Power Distribution Blocks



Short-Circuit Current Rated Power Distribution Blocks

We offer distinctly different styles of short-circuit current rated Power Distribution Blocks and Terminal Blocks to match different application needs. The different features are:

- 1) Enclosed style or Open style
- 2) UL1953 Listed power distribution blocks or UL1059 Recognized terminal blocks, that have different minimum spacing requirements.

The table below can assist in the selection of the correct series for your application requirements.

Why are these important?

Assembly short-circuit current ratings (SCCRs) are now required in the 2005 NEC® and UL508A Listed industrial control panels.

Marking the SCCR on:

- Industrial Control Panels (NEC®409.110)
- Industrial Machinery Electrical Panels (NEC®670.3(A))
- HVAC equipment (NEC®440.4(B))

The above sections are now required by the National Electrical Code. Power Distribution Blocks or Terminal Blocks not marked with an SCCR are typically one of the weakest links and may limit an assembly to no more than 10 kA SCCR per Table SB4.1 UL508A. The EPDB series and HPB series Power Distribution Blocks have increased spacing required where used in feeder circuits in equipment listed to UL508A. The PB series UL1059 Terminal Blocks must be evaluated for proper spacing. Also, for building wiring systems, the EPDB series and HPB series power distribution blocks can be used to meet the 2005 NEC® requirements in section 376.56(B) for power distribution blocks in wireways.

Edison Power Distribution Blocks Selection Guide*								
Series	UL	† Enclosed	High SCCR**	Spacing*** 1" Air 2" Surface	Industrial Control Panels UL 508A Branch Circuit	Industrial Control Panels UL 508A Feeder Circuit	HVAC UL 1995	Wireways NEC® 376.56(B) (Requires UL 1953)
EPDB	UL 1953 Listed Power Distribution Blocks	Yes	Yes	Yes	Yes	Yes	Yes	Yes
HPB	UL 1953 Listed Power Distribution Blocks	No****	Yes	Yes	Yes	Yes	Yes	Yes (with optional cover)
PB	UL 1059 Recognized Terminal Blocks	No****	Yes	No*****	Yes	No*****	Yes	No

† IP-20 finger-safe under specific conditions.

*Refer to specific UL standards and NEC sections for a complete application guide.

**When protected by proper fuse class with maximum ampere rating specified or smaller. This does not apply to PB40, PB51 and PB71 series.

***See Minimum Space Requirements for Equipment table below.

****Optional covers are available. They are not IP-20 rated, but do provide additional protection against direct contact with Live Parts.

*****Exception: Yes, if single pole units installed with proper spacings.

Minimum Space Requirements for Equipment			
UL Standard	Spacing Between Live Parts of Opposite Polarity		Spacing Between Live Parts and Grounded Parts or Enclosures, Through Air and Over Surface @ 600V
	Through Air @ 600V	Over Surface @ 600V	
508A Feeder Circuits, Table 10.2	1"	2"	1"
508A Branch Circuits, Table 10.1	3/8"	1/2"	1/2"
UL 1995 HVAC	3/8"	1/2"	1/2"

Note: Refer to specific UL standards for complete spacing details.

HPB Series Edison Open-Style Power Distribution Blocks

Open-style power distribution blocks for cable termination

Edison open-style power distribution blocks are a convenient way to manage your power distribution needs. They are engineered to maintain a high SCCR rating of 200kA with copper conductors making these distribution blocks the ideal solution to today's power circuit wiring needs.



Features

- Suitable for industrial control panel applications requiring high SCCR ratings
- Suitable for installation in wireways (with optional cover, per NEC 376.56 (B))
- Has minimum spacing requirements at 600VAC/DC of at least 1" through air and 2" over surface which meets UL 1953 requirements
- Used in UL508A panels
- Meets UL508A requirements and can be used in feeder and branch circuit applications
- Tin-plated aluminum connectors suitable for copper conductors
- Available safety covers for greater protection (purchase separately)
- Suitable for both factory and field wiring
- Panel mounting

Ratings

- Ampere ratings up to 310 Amps
- 600 VAC or VDC
- Short Circuit Current Rating (SCCR) up to 200kA with proper fusing (See short circuit rating data table)
- Flammability: UL 94V0

Agency Approvals

- UL Listed - File E333541 Guide QPOS
- CE

Standards

- UL1953

Open-Style Power Distribution Blocks Selection Table

Series	Part Number	Amps	Description	SCCR Rtg	Pcs/Pkg	Wt.	Price
HPB Series	HPB101-1	175 max	1 pole distribution block, 1 in/1 out	200kA	1	0.2 lb	<--->
	HPB101-3	175 max	3 pole distribution block, 1 in/1 out	200kA	1	0.8 lb	<--->
	HPB104-1	175 max	1 pole distribution block, 1 in/4 out	200kA	1	0.2 lb	<--->
	HPB104-3	175 max	3 pole distribution block, 1 in/4 out	200kA	1	0.8 lb	<--->
	HPB10S-1	175 max	1 pole distribution block, 1 in/stud out	200kA	1	0.6 lb	<--->
	HPB10S-3	175 max	3 pole distribution block, 1 in/stud out	200kA	1	1.0 lb	<--->
	HPB106-1	175 max	1 pole distribution block, 1 in/6 out	200kA	1	1.4 lb	<--->
	HPB106-2	175 max	2 pole distribution block, 1 in/6 out	200kA	1	0.2 lb	<--->
	HPB106-3	175 max	3 pole distribution block, 1 in/6 out	200kA	1	0.8 lb	<--->
	HPB306-1	310 max	1 pole distribution block, 1 in/6 out	200kA	1	0.7 lb	<--->
	HPB306-3	310 max	3 pole distribution block, 1 in/6 out	200kA	1	2.9 lb	<--->
	HPB309-1	310 max	1 pole distribution block, 1 in/9 out	200kA	1	0.8 lb	<--->
	HPB309-3	310 max	3 pole distribution block, 1 in/9 out	200kA	1	3.0 lb	<--->
	HPB312-1	310 max	1 pole distribution block, 1 in/12 out	200kA	1	0.8 lb	<--->
HPB312-3	310 max	3 pole distribution block, 1 in/12 out	200kA	1	3.2 lb	<--->	



HPB104-1



HPB10S-3



HPB106-3



HPB309-1



HPB312-3

Open-Style Power Distribution Block General Specifications

Wire type	75°C* Copper
Voltage	600 VAC or VDC maximum
Mounting	Surface mount
*Note: Amp Rating based on NEC table 310.16 for 75°C copper wire.	

Optional Covers

Covers are ordered for each individual pole, i.e., three 1-pole covers for 3-pole block, see Table A. Except HPB106 blocks have one cover for 1-, 2-, or 3-pole versions, see Table B. (Shipped with mounting screws)

Table A

Block	Cover
HPB1XX-(pole)	PBC21
HPB3XX-(pole)	PBC31

Table B

Block	Cover
HPB106-1	PBC31
HPB106-2	PBC32
HPB106-3	PBC33

HPB Series Edison Open-Style Power Distribution Blocks

Edison Open-Style Power Distribution Blocks Wire and Torque Range Specifications								
Part Number	Line				Load			
	CU Wire Range	Torque Lb-in (Nm)	Trim Length in (mm)	Hex Key	CU Wire Range	Torque Lb-in (Nm)	Trim Length in (mm)	Hex Key
HPB101-1, HPB101-3	2/0 to 8 AWG 70 to 10 mm ²	110 (12.4)	0.700 (17.8)	3/16"	2/0 to 8 AWG, 70 to 10 mm ²	110 (12.4)	0.700 (17.8)	3/16" Hex
HPB104-1, HPB104-3	2/0 to 8 AWG 70 to 10 mm ²	120 (13.6)	0.670 (17.0)	3/16"	4 to 6 AWG, 25 to 16 mm ² 8 AWG, 10 mm ² 10 to 14 AWG, 6 to 2.5 mm ²	35 (4.0) 25 (2.8) 20 (2.3)	0.470 (11.9) top row, 0.780 (19.8) bottom row	Slot
HPB10S-1, HPB10S-3	2/0 to 8 AWG 70 to 10 mm ²	120 (13.6)	0.670 (17.0)	3/16"	N/A	50 (5.7)	N/A	1/4-20 Stud
HPB106-1, HPB106-2, HBP106-3	2/0 to 8 AWG 70 to 10 mm ²	120 (13.6)	0.700 (17.8)	3/16"	4 to 6 AWG, 25 to 16 mm ² 8 AWG, 10 mm ² 10 to 14 AWG, 6 to 2.5 mm ²	35 (4.0) 25 (2.8) 20 (2.3)	0.480 (12.2) top row, 0.800 (20.3) bottom row	Slot
HPB306-1, HPB306-3	350 kcmil to 4 AWG 185 to 25 mm ²	275 (31.1)	0.900 (22.9)	5/16"	4 to 6 AWG, 25 to 16 mm ² 8 AWG, 10 mm ² 10 to 12 AWG, 6 to 4 mm ²	35 (4.0) 25 (2.8) 20 (2.3)	1.00 (25.4) top row, 0.450 (11.43) bottom row	Slot
HPB309-1, HPB309-3	350 kcmil to 4 AWG 185 to 25 mm ²	275 (31.1)	0.900 (22.9)	5/16"	2 to 3 AWG, 35 mm ² 4 to 6 AWG, 25 to 16 mm ² 8 AWG, 10 mm ² 10 to 12 AWG, 6 to 4 mm ²	50 (5.7) 45 (5.1) 40 (4.5) 35 (4.0)	0.450 (11.4) top row, 0.630 (16.0) middle row, 0.920 (23.4) bottom row	Slot top row, Slot middle row, 3/16" Hex bottom row
HPB312-1, HPB312-3	350 kcmil to 4 AWG 185 to 25 mm ²	275 (31.1)	0.900 (22.9)	5/16"	4 to 6 AWG, 25 to 16 mm ² 8 AWG, 10 mm ² 10 to 14 AWG, 6 to 2.5 mm ²	35 (4.0) 25 (2.8) 20 (2.3)	0.450 (11.4) top row, 0.630 (16.0) middle row, 0.920 (23.4) bottom row	Slot

Short-Circuit Current Rating Data										
Part Number (All Single Pole)	Capacity*	Line		Load		Maximum Fuse Class and Amps**				
		Openings per Pole	Wire Range (copper only)	openings per Pole	Wire Range (copper only)	Class J(JDL)	Class T (A3T/A6T)	Class RK1 (LENRK/LESRK)	Class RK5 (ECNR/ECSR)	SCCR Rating
HPB101-1, HPB101-3	175 A	1	2/0 to 8 AWG 70 to 10 mm ²	1	2/0 to 8 AWG 70 to 10 mm ²	200	200	200	60	200kA
HPB104-1, HPB104-3	175 A	1	2/0 to 8 AWG 70 to 10 mm ²	4	4 to 12 AWG 25 to 4 mm ² 14 AWG 2.5 mm ²	200 175 200	200 175 200	200 100 100	60 60 60	200kA 100kA 50kA
HPB10S-1, HPB10S-3	175 A	1	2/0 to 8 AWG 70 to 10 mm ²	Stud	1/4-20 x 3/4 Stud	200	200	100	60	200kA
HPB106-1, HPB106-2, HBP106-3	175 A	1	2/0 to 8 AWG 70 to 10 mm ²	6	4 to 12 AWG 25 to 4 mm ² 14 AWG 2.5 mm ²	400 400 175	400 400 175	200 400 100	100 100 60	200kA 100kA 100kA
HPB306-1, HPB306-3	310 A	1	350 kcmil to 4 AWG 185 to 12 mm ²	6	4 to 8 AWG 25 to 10 mm ² 10 to 12 AWG 6 to 4 mm ²	400 400 175	400 400 175	200 400 100	100 100 60	200kA 100kA 100kA
HPB309-1, HPB309-3	310 A	1	350 kcmil to 4 AWG 185 to 12 mm ²	9	1/0 to 6 AWG 50 to 16 mm ² 8 to 12 AWG 10 to 4 mm ²	400 400 175	400 400 175	200 400 100	100 100 60	200kA 100kA 100kA
HPB312-1, HPB312-3	310 A	1	350 kcmil to 4 AWG 185 to 12 mm ²	12	4 to 8 AWG 25 to 10 mm ² 10 to 14 AWG 6 to 2.5 mm ²	400 175	400 175	200 100	100 60	200kA 100kA

*Amp ratings are based on NEC® Table 310.16 for 75°C copper wire and UL508A Table 28.1.

**Class G 60A or less, or Class CC 30A or less fuses are suitable for all SCCRs in this table.

HPB Series Edison Open-Style Power Distribution Block Dimensions

Edison Open-Style Power Distribution Blocks Dimensions (in[mm])						
Part Number	Width	Length	Height	D	E	F
	A	B	C			
HPB306-3, HPB312-3, HPB309-3	6.00 [152.4]	5.50 [139.7]	3.70 [93.9]	3.25 [82.6]	4.75 [120.7]	0.22 [5.7]
HPB306-1, HPB312-1, HPB309-1	1.96 [49.8]	3.38 [85.9]	3.32 [84.3]	-	3.38 [85.8]	0.21 [2.5] x 0.41 [10.4]
HPB101-3, HPB104-3, HPB10S-3	4.27 [108.3]	2.88 [73.2]	2.13 [54.0]	1.62 [41.1]	2.25 [57.2]	0.22 [5.7]
HPB101-1, HPB104-1, HPB10S-1	1.07 [27.2]	2.88 [73.2]	1.75 [44.5]	-	2.25 [57.2]	0.20 [5.1]
HPB106-1	1.96 [49.8]	4.00 [101.6]	3.32 [84.3]	1.62 [41.1]	3.37 [85.6]	0.21 [2.5] x 0.41 [10.4]
HPB106-2	3.58 [90.9]	4.00 [101.6]	3.32 [84.3]	1.62 [41.1]	3.37 [85.6]	0.21 [2.5] x 0.41 [10.4]
HPB106-3	5.20 [132.1]	4.00 [101.6]	3.32 [84.3]	1.62 [41.1]	3.37 [85.6]	0.21 [2.5] x 0.41 [10.4]

HPB101-1, HPB104-1, HPB10S-1

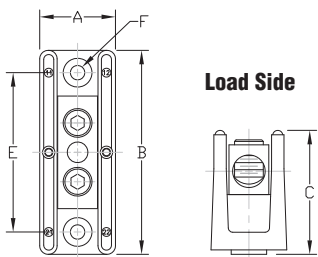

HPB101-3, HPB104-3, HPB10S-3

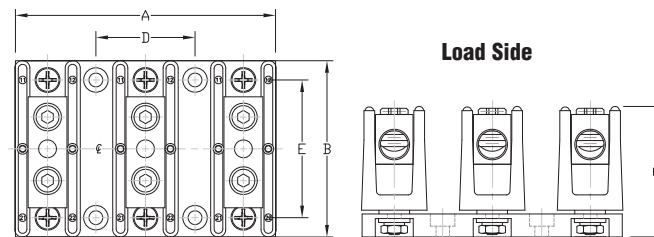

HPB106-1, HPB106-2, HPB106-3

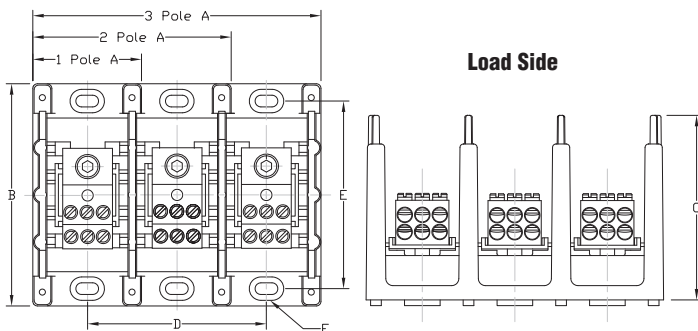

HPB306-1, HPB312-1, HPB309-1

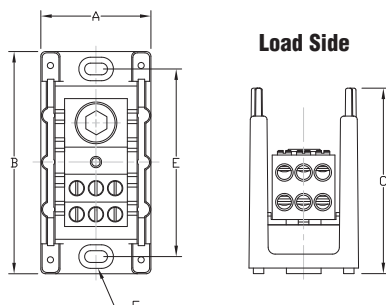

HPB306-3, HPB312-3, HPB309-3

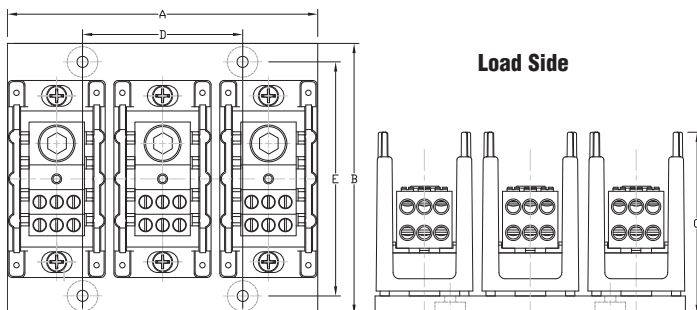

HPB Series Edison Open-Style Power Distribution Blocks Optional Covers

Covers

Optional Cover for
HPB101-1, HPB101-3,
HPB104-1, HPB104-3
HPB10S-1, HPB10S-3,

Note: One PBC21 will be required for each pole. For example the HPB101-1 will require 1 Qty. HPB101-3 will require 3 Qty.

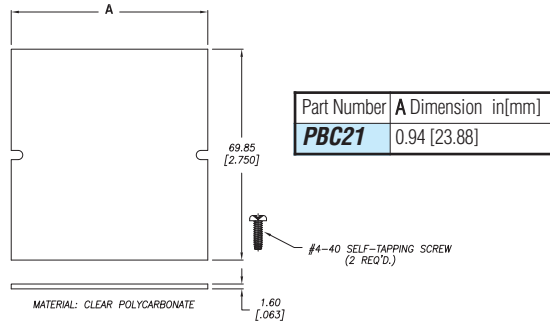

Optional Cover for
HPB306-1, HPB306-3,
HPB309-1, HPB309-3,
HPB312-1, HPB312-3

Note: One PBC31 will be required for each pole. For example the HPB306-1 will require 1 Qty. HPB306-3 will require 3 Qty.

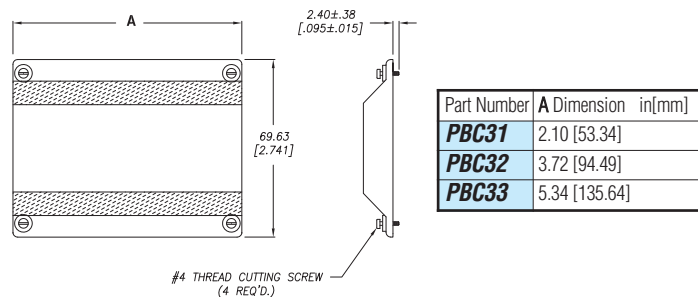

Optional Cover for
HPB106-1 = PBC31
HPB106-2 = PBC32
HPB106-3 = PBC33

Note: Dimensions are in inches [millimeters]

Part No.	Minimum Enclosure Size*
HPB101-1, HPB101-3	16" x 16" x 6.75" [406.4mm x 406.4mm x 171.5mm]
HPB104-1, HPB104-3	16" x 16" x 6.75" [406.4mm x 406.4mm x 171.5mm]
HPB10S-1, HPB10S-3	16" x 16" x 6.75" [406.4mm x 406.4mm x 171.5mm]
HPB106-1, HPB106-2, HPB106-3	24" x 20" x 6.76" [609.6mm x 508mm x 171.5mm]
HPB306-1, HPB306-3	24" x 20" x 6.76" [609.6mm x 508mm x 171.5mm]
HPB309-1, HPB309-3	24" x 20" x 6.76" [609.6mm x 508mm x 171.5mm]
HPB312-1, HPB312-3	24" x 20" x 6.76" [609.6mm x 508mm x 171.5mm]

**Power distribution blocks SCCR determined based on testing in minimum size enclosure.*

Edison Open-Style Power Distribution Blocks Quick Reference

Openings per pole	Type	175 amps	310 amps	380 amps	570 amps	760 amps
1 in 1 out	Open UL1059	PB101x	NO	NO	NO	NO
	Open UL1953 Listed	HPB101-x	HPB101-x	NO	NO	NO
	Finger Safe UL1953 Listed	EPDB101	EPDB301	NO	NO	NO
1 in 1 stud out	Open UL1059	NO	NO	PB401x	NO	NO
	Open UL1953 Listed	HPB10S-x	NO	NO	NO	NO
	Finger Safe UL1953 Listed	NO	NO	NO	NO	NO
2 in 2 out	Open UL1059	NO	NO	NO	NO	NO
	Open UL1953 Listed	NO	NO	NO	NO	NO
	Finger Safe UL1953 Listed	NO	NO	NO	NO	EPDB702
1 in 4 out	Open UL1059	PB104x	NO	NO	NO	NO
	Open UL1953 Listed	HPB104-x	HPB104-x	NO	NO	NO
	Finger Safe UL1953 Listed	EPDB104	NO	NO	NO	NO
1 in 6 out	Open UL1059	NO	PB306x	NO	NO	NO
	Open UL1953 Listed	HPB106-x	HPB306-x	NO	NO	NO
	Finger Safe UL1953 Listed	NO	NO	EPDB306	NO	NO
1 in 9 out	Open UL1059	NO	NO	NO	NO	NO
	Open UL1953 Listed	NO	HPB309-x	NO	NO	NO
	Finger Safe UL1953 Listed	NO	NO	NO	NO	NO
1 in 12 out	Open UL1059	NO	PB312x	NO	NO	NO
	Open UL1953 Listed	NO	HPB312-x	NO	NO	NO
	Finger Safe UL1953 Listed	NO	NO	NO	NO	NO
2 in 12 out	Open UL1059	NO	NO	NO	PB512x	PB712x
	Open UL1953 Listed	NO	NO	NO	NO	NO
	Finger Safe UL1953 Listed	NO	NO	NO	EPDB512	NO