

Edison Power Distribution Blocks



Short-Circuit Current Rated Power Distribution Blocks

We offer distinctly different styles of short-circuit current rated power distribution blocks (PDBs) and terminal blocks (TBs) to match different application needs. The differences are whether the power distribution blocks are enclosed or not, and whether they are UL1953 Listed PDBs or UL1059 Recognized TBs, which have different minimum spacing requirements. The table below can assist in the selection of the right series for your application requirements.

Why are these important?

Assembly short-circuit current ratings (SCCRs) are now required in the 2005 NEC® and UL508A Listed Industrial Control Panels. Marking the SCCR on Industrial Control Panels (NEC® 409.110), Industrial Machinery Electrical Panels (NEC® 670.3(A)), and HVAC equipment (NEC® 440.4(B)) is now required by the National Electrical Code. Power distribution blocks or terminal blocks not marked with an SCCR are typically one of the weakest links and may limit an assembly to no more than 10 kA SCCR. The EPDB Series has increased spacing required where used in feeder circuits in equipment listed to UL508A (UL1059 terminal blocks must be evaluated for proper spacings). Also, for building wiring systems, the EPDB Series power distribution blocks can be used to meet the 2005 NEC® requirements in section 376.56(B) for power distribution blocks in wireways.

| Edison Power Distribution Blocks Selection Guide | | | | | | | | |
|--|--|------------|------------|-----------------------------------|--|--|-----------------|--|
| Series | UL | † Enclosed | High SCCR* | Spacing** 1" Air 2" Surface | Industrial Control Panels UL 508A Branch Circuit | Industrial Control Panels UL 508A Feeder Circuit | HVAC UL 1995 | Wireways NEC® 376.56(B) (Requires UL 1953) |
| EPDB | UL 1953 Listed Power Distribution Blocks | Yes | Yes | Yes | Yes | Yes | Yes | Yes |
| PB | UL 1059 Recognized Terminal Blocks | No*** | Yes | No**** | Yes | No**** | Yes | No*** |

† IP-20 finger-safe under specific conditions. See page B26-5.

*When protected by proper fuse class with maximum ampere rating specified or smaller. This does not apply to PB40, PB51 and PB71 series.

**See Minimum Space Requirements for Equipment table below.

***Optional covers are available. They are not IP-20 rated, but do provide additional protection against direct contact with Live Parts.

****Exception: Yes, if single pole units installed with proper spacings.

| Minimum Space Requirements for Equipment | | | |
|--|---|---------------------|--|
| UL Standard | Spacing Between Live Parts of Opposite Polarity | | Spacing Between Live Parts and Grounded Parts or Enclosures, Through Air and Over Surface @ 600V |
| | Through Air @ 600V | Over Surface @ 600V | |
| 508A Feeder Circuits, Table 10.2 | 1" | 2" | 1" |
| 508A Branch Circuits, Table 10.1 | 3/8" | 1/2" | 1/2" |
| UL 1995 HVAC | 3/8" | 1/2" | 1/2" |

Note: Refer to specific UL standards for complete spacing details.

Edison Finger-Safe Power Distribution Blocks

Finger-safe distribution blocks

Use Finger-safe Power Distribution Blocks to manage your power distribution needs, from splitting primary power circuits into a variety of branch circuits to providing a fixed junction tap-off point. The modular design allows the end user to select and configure the number of poles required by each application. These blocks are engineered to allow copper conductors and maintain an SCCR rating of 200kA. These features make these blocks the perfect solution to today's power circuit wiring requirements.

Features

- Fully enclosed block for touch-safe isolation of live parts
- IP20 rating under specific conditions
- Integrated DIN-rail or direct panel mounting. (Panel mount only for EPDB306 and EPDB702)
- Captive termination screws cannot be lost
- Used in UL508A panels for both feeder and branch circuit applications
- Suitable for both factory and field wiring
- Tin-plated aluminum connectors suitable for copper conductors

Ratings

- Ampere ratings from 175 Amps to 760
- 600 VAC or VDC
- Short Circuit Current Rating (SCCR) 200kA with proper fusing
- Flammability: UL 94V0

Agency Approvals

- UL 1953 Listed - File E256146, Guide QPQS
 - CSA Certified - Class 6228-01, File 700490
 - CE component IEC 60947-7-1
 - IEC-60529, IP20 (Finger-Safe)
- See table for specific conditions.

| Finger-safe Power Distribution Blocks Selection Table | | | | | | | |
|---|-------------|---------|--|----------|---------|----------|-------|
| Series | Part Number | Amps | Description | SCCR Rtg | Pcs/Pkg | Wt. | Price |
| Finger-safe (EPDB) | EPDB101 | 175 max | 1 pole distribution block, 1 in/1 out | 200 kA | 1 | 3.4 oz. | <---> |
| | EPDB104 | 175 max | 1 pole distribution block, 1 in/4 out | 200 kA | 1 | 4.2 oz. | <---> |
| | EPDB301 | 310 max | 1 pole distribution block, 1 in/1 out | 200 kA | 1 | 8.1 oz. | <---> |
| | EPDB306 | 380 max | 1 pole distribution block, 1 in/6 out | 200 kA | 1 | 9.1 oz. | <---> |
| | EPDB512 | 570 max | 1 pole distribution block, 2 in/12 out | 200 kA | 1 | 12.5 oz. | <---> |
| | EPDB702 | 760 max | 1 pole distribution block, 2 in/2 out | 200 kA | 1 | 16.4 oz. | <---> |
| Accessory | DN-EB35* | - | End bracket | - | 50 | 1.87 lb. | <---> |

*Note: DIN-rail anchors are required on block or blocks. Anchors must be used to prevent damage to the plastic housing when tightening terminals.

| Finger-safe Power Distribution Block General Specifications | |
|---|---|
| Wire Type | 75°C*, Cu |
| Voltage | 600 VAC or VDC maximum (UL 1953), 690 VAC/VDC (IEC) |
| Operating Temperature | -10°C to 60°C (14°F to 140°F) |
| Storage Temperature | -20°C to 60°C (-4°F to 140°F) |
| Mounting | 35mm DIN rail (DN-R35S1) or surface mount. |

*Note: Amp Rating is based on NEC table 310.16 for 75°C copper wire.



Edison Finger-Safe Power Distribution Blocks Specifications

Company Info.

PLCs

Field I/O

Software

C-more & other HMI

AC Drives

AC Motors

Power Transmiss.

Steppers/ Servos

Motor Controls

Proximity Sensors

Photo Sensors

Limit Switches

Encoders

Current Sensors

Pressure Sensors

Temp. Sensors

Pushbuttons/ Lights

Process

Relays/ Timers

Comm.

Terminal Blocks & Wiring

Power

Circuit Protection

Enclosures

Tools

Pneumatics

Appendix

Part Index

| Edison Finger-Safe Power Distribution Blocks Wire and Torque Range Specifications | | | | | | | | | |
|---|---|-------------------|--|---------|---|-------------------|---|---------|--|
| Part Number | Line | | | | Load | | | | |
| | CU Wire Range | Torque Lb-in (Nm) | Trim Length in (mm) | Hex Key | CU Wire Range | Torque Lb-in (Nm) | Trim Length in (mm) | Hex Key | |
| EPDB101 | 2/0 to 8 AWG, 70 to 10 mm ² | 110 [12.4] | 0.850 [21.6] | 3/16" | 2/0 to 8 AWG, 70 to 10 mm ² | 110 [12.4] | 0.970 [24.6] | 3/16" | |
| EPDB104 | 2/0 to 8 AWG, 70 to 10 mm ² | 120 [13.6] | 0.750 [19.0] | 3/16" | 4 to 12 AWG, 25 to 16 mm ² | 35 [4.0] | 0.550 [14.0] top row, 0.850 [21.6] bottom row | 1/8" | |
| | | | | | 8 AWG, 10 mm ² | 25 [2.8] | | | |
| | | | | | 10 to 14 AWG, 6 to 2.5 mm ² | 20 [2.3] | | | |
| EPDB301 | 350 kcmil to 6 AWG, 185 to 16 mm ² | 275 [31.1] | 1.350 [34.3] | 5/16" | 350 Kcmil to 6 AWG, 185 to 16 mm ² | 275 [31.1] | 1.250 [31.8] | 5/16" | |
| EPDB306 | 500 kcmil to 6 AWG, 240 to 16 mm ² | 500 [56.5] | 1.250 [31.8] | 3/8" | 2 to 3 AWG, 35 mm ² | 50 [5.7] | 0.590 [15.0] top row 1.200 [30.5] bottom row | 1/8" | |
| | | | | | 4 to 6 AWG, 25 to 16 mm ² | 45 [5.1] | | | |
| | | | | | 8 AWG, 10 mm ² | 40 [4.5] | | | |
| | | | | | 10 to 14 AWG, 6 to 2.5 mm ² | 35 [4.0] | | | |
| EPDB512 | 300 kcmil to 4 AWG, 150 to 25mm ² | 275 [31.1] | 1.15 [29.2] top row 1.400 [35.6] bottom row | 1/4" | 4 to 6 AWG, 25 to 16 mm ² | 35 [4.0] | 0.550 [14.0] top row, 1.00 [25.4] middle row, 1.220 [31.0] bottom row | 1/8" | |
| | | | | | 8 AWG, 10 mm ² | 25 [2.8] | | | |
| | | | | | 10 to 14 AWG, 6 to 2.5 mm ² | 20 [2.3] | | | |
| EPDB702 | 500 kcmil to 6 AWG, 240 to 16 mm ² | 500 [56.5] | 1.250 [31.8] | 3/8" | 500 kcmil to 6 AWG, 240 to 16 mm ² | 500 [56.5] | 1.250 [31.8] | 3/8" | |

| Short-Circuit Current Rating Data | | | | | | | | | | |
|-----------------------------------|-----------|-------------------|---|-------------------|---|--------------------------------|-------------------|-------------------------|-----------------------|-------------|
| Part Number (All Single Pole) | Capacity* | Line | | Load | | Maximum Fuse Class and Amps*** | | | | |
| | | Openings per Pole | Wire Range (copper only) | openings per Pole | Wire Range (copper only) | Class J(JDL) | Class T (A3T/A6T) | Class RK1 (LENRK/LESRK) | Class RK5 (ECNR/ECSR) | SCCR Rating |
| EPDB101 | 175A | 1 | 2/0 to 8 AWG 70 to 10 mm ² | 1 | 2/0 to 8 AWG 70 to 10 mm ² | 200 | 200 | 100 | 60 | 200 kA |
| EPDB104 | 175A | 1 | 2/0 to 8 AWG 70 to 10 mm ² | 4 | 4 to 6 AWG 25 to 16 mm ² | 200 | 200 | 100 | 60 | 200 kA |
| | | | | | 4 to 14 AWG 25 to 2.5 mm ² | 175 | 175 | 100 | 60 | 100 kA |
| | | | | | | 200 | 200 | 100 | 60 | 50 kA |
| EPDB301 | 310A | 1 | 350 kcmil to 6 AWG 185 to 16 mm ² | 1 | 350 kcmil to 6 AWG 150 to 16 mm ² | 400 | 400 | 200 | 100 | 200 kA |
| EPDB306 | 380A | 1 | 500 kcmil to 6 AWG 240 to 16 mm ² | 6 | 2 to 6 AWG 35 to 16 mm ² | 400 | 400 | 200 | 100 | 200 kA |
| | | | | | 2 to 14 AWG 35 to 2.5 mm ² | 200 | 200 | 100 | 30 | 50 kA |
| | | | | | | 175 | 175 | 100 | 30 | 100 kA |
| EPDB512 | 570A | 2 | 300 kcmil 150 mm ² | 12 | 4 to 8 AWG 25 to 10 mm ² | 600 | 600 | 400 | 200 | 200 kA |
| | | | 300 kcmil to 4 AWG 150 to 12 mm ² | | 4 AWG 25 mm ² | 600 | 600 | 400 | 200 | 50 kA |
| | | | | | 4 to 14 AWG 25 to 2.5 mm ² | 200 | 200 | 100 | 30 | 50 kA |
| EPDB702 | 760A | 2 | 500 kcmil 240 mm ² | 2 | 500 kcmil 240 mm ² | 600 | 800** | 600 | 400 | 200 kA |
| | | | 500 kcmil to 6 AWG 240 to 16 mm ² | | 600 | 800** | 600 | 600 | 100 kA | |
| | | | | | 500 kcmil to 6 AWG 240 to 16 mm ² | 600 | 600 | 400 | 200 | 100 kA |

*Amp ratings are based on NEC® Table 310.16 for 75°C copper wire and UL508A Table 28.1.

**Class L 800A or less fuses are suitable for this particular SCCR case.

***Class G 60A or less, or Class CC 30A or less fuses are suitable for all SCCRs in this table.

Edison Finger-Safe Power Distribution Blocks Dimensions

| Edison Finger-Safe Power Distribution Blocks Dimensions (in[mm]) | | | | | | | | |
|--|---------------|----------------|---------------|----------------|---------------|--------------|--------------|--------------|
| Part Number | Width | Length | Height | D | E | F | G | H |
| | A | B | C | | | | | |
| EPDB101 | 1.030 [26.16] | 3.372 [85.65] | 2.146 [54.50] | 3.550 [90.17] | 2.905 [73.79] | 0.197 [5.00] | 0.197 [5.00] | N/A |
| EPDB104 | 1.030 [26.16] | 3.372 [85.65] | 2.146 [54.50] | 3.550 [90.17] | 2.905 [73.79] | 0.197 [5.00] | 0.197 [5.00] | N/A |
| EPDB301 | 1.550 [39.37] | 4.665 [118.50] | 2.874 [73.00] | 4.475 [113.67] | 3.810 [96.77] | 0.197 [5.00] | 0.236 [6.00] | N/A |
| EPDB306 | 1.550 [39.37] | 4.665 [118.50] | 2.950 [74.93] | 4.475 [113.67] | 3.810 [96.77] | 0.197 [5.00] | 0.236 [6.00] | N/A |
| EPDB512 | 1.875 [47.62] | 4.665 [118.50] | 2.933 [74.50] | 4.475 [113.67] | 3.810 [96.77] | 0.197 [5.00] | 0.236 [6.00] | N/A |
| EPDB702 | 2.560 [65.02] | 4.665 [118.50] | 3.150 [80.00] | 4.475 [113.67] | 3.810 [96.77] | 0.197 [5.00] | 0.236 [6.00] | 46.00 [1.81] |

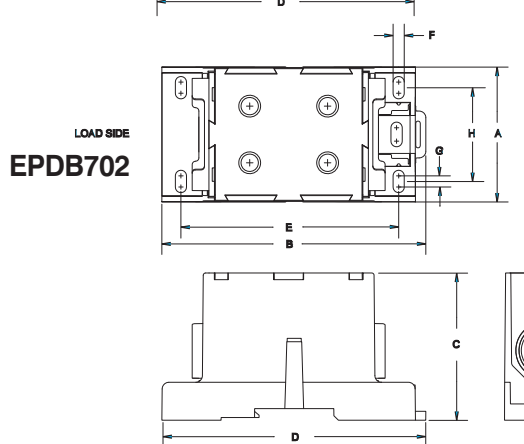
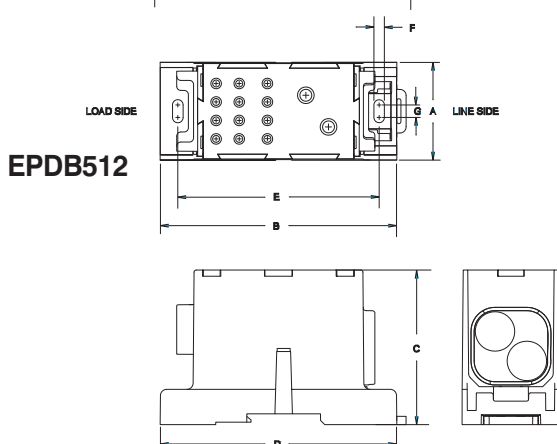
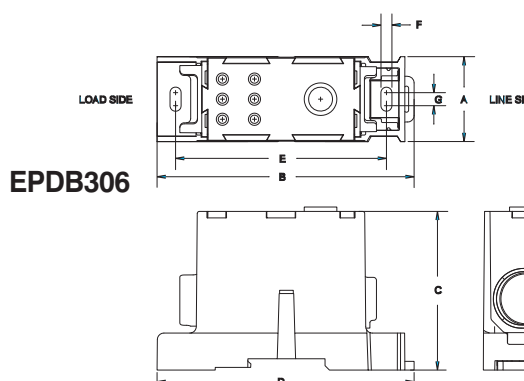
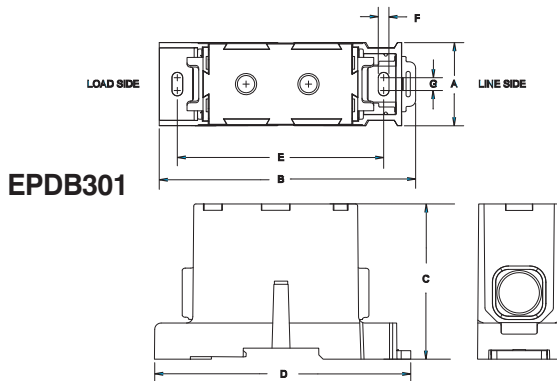
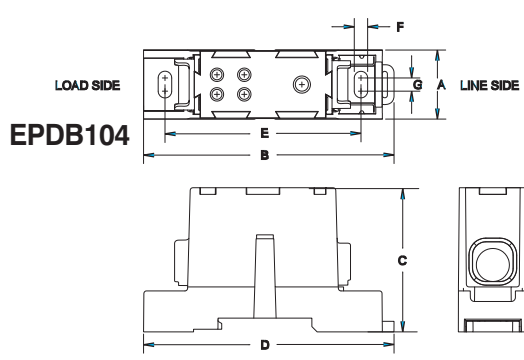
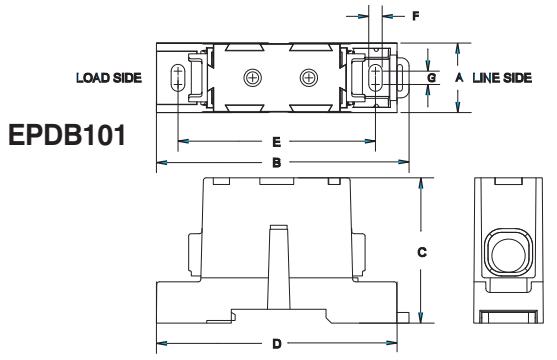

| Part Number | Minimum Enclosure Size in(mm)* |
|-------------|---|
| EPDB101 | 16 x 16 x 6.75 [406.4 x 406.4 x 171.45] |
| EPDB104 | 16 x 16 x 6.75 [406.4 x 406.4 x 171.45] |
| EPDB301 | 36 x 30 x 12.63 [914.4 x 762 x 320.80] |
| EPDB306 | 24 x 20 x 6.75 [609.6 x 508 x 171.45] |
| EPDB512 | 24 x 20 x 6.75 [609.6 x 508 x 171.45] |
| EPDB702 | 36 x 30 x 12.63 [914.4 x 762 x 320.80] |

*Note: Terminal block SCCR determined based on testing in minimum-size enclosure

| Part Number | Wire Connector Hole Diameter | |
|-------------|------------------------------|---------------|
| | Line in (mm) | Load in (mm) |
| EPDB101 | 0.450 [11.43] | 0.450 [11.43] |
| EPDB104 | 0.450 [11.43] | 0.246 [6.25] |
| EPDB301 | 0.720 [18.29] | 0.720 [18.29] |
| EPDB306 | 0.870 [22.10] | 0.314 [7.98] |
| EPDB512 | 0.687 [17.45] | 0.265 [6.73] |
| EPDB702 | 0.875 [22.23] | 0.875 [22.23] |

Edison Finger-Safe Power Distribution Blocks

IP-20 Finger-safe Status Requirements

- Company Info.
- PLCs
- Field I/O
- Software
- C-more & other HMI
- AC Drives
- AC Motors
- Power Transmiss.
- Steppers/ Servos
- Motor Controls
- Proximity Sensors
- Photo Sensors
- Limit Switches
- Encoders
- Current Sensors
- Pressure Sensors
- Temp. Sensors
- Pushbuttons/ Lights
- Process
- Relays/ Timers
- Comm.
- Terminal Blocks & Wiring**
- Power
- Circuit Protection
- Enclosures
- Tools
- Pneumatics
- Appendix
- Part Index

| Specific Conditions to Achieve IP-20 Finger-Safe Status for EPDB Series | | | | | | | | |
|---|---|---|--------------------|---------------|---|--|--------------------|---------------|
| Part Number | Line | | | | Load | | | |
| | Trim Length in [mm] | Installed Wire | IP-20 | | Trim Length in [mm] | Installed Wire | IP-20 | |
| | | | Conductor Openings | Screw Opening | | | Conductor Openings | Screw Opening |
| EPDB101 | 0.850 [21.6] | 2/0 to 8 AWG 70 to 10mm ² | Yes | Yes | 0.970 [24.6] | 2/0 to 8 AWG 70 to 10mm ² | Yes | Yes |
| EPDB104 | 0.750 [19.0] | 2/0 to 8 AWG 70 to 10mm ² | Yes | Yes | 0.550 [14.0] top row, 0.850 [21.6] bottom row | 4 to 14 AWG 25 to 2.5mm ² | Yes | Yes |
| | | | | | | screws fully opened | N/A | Yes |
| | | | | | | no wire in hole | No | N/A |
| EPDB301 | 1.350 [34.3] | 350 Kcmil to 2/0 AWG 185 to 70mm ² | Yes | Yes | 1.250 [31.8] | 350 Kcmil to 2/0 AWG 185 to 70mm ² | Yes | Yes |
| | | 1/0 to 6 AWG 50 to 16mm ² | No | Yes | | 1/0 to 6 AWG 50 to 16mm ² | No | Yes |
| EPDB306 | 1.250 [31.8] | 500 to 250 Kcmil 240 to 150mm ² | Yes | Yes | 0.590 [15.0] top row, 1.200 [30.5] bottom row | 2 to 14 AWG 35 to 2.5mm ² | Yes | Yes |
| | | 4/0 to 6 AWG 120 to 16mm ² | No | Yes | | screws fully opened | N/A | Yes |
| | | N/A | N/A | N/A | | no wire in hole | No | N/A |
| EPDB512 | 1.15 [29.2] top row, 1.400 [35.6] bottom row | 300 Kcmil to 4/0 AWG 150 to 120mm ² | Yes | Yes | 0.550 [14.0] top row 1.00 [25.4] middle row 1.220 [31.0] bottom row | 4 to 14 AWG 25 to 2.5mm ² | Yes | Yes |
| | | 3/0 to 4 AWG 95 to 25mm ² | No | Yes | | screws fully opened | N/A | Yes |
| | | screws fully opened | N/A | No | | no wire in hole | Yes | N/A |
| | | no wire in hole | No | N/A | | | | |
| EPDB702 | 1.250 [31.8] | 500 to 350 Kcmil 240 to 185mm ² | Yes | Yes | 1.250 [31.8] | 500 to 350 Kcmil 240 to 185mm ² | Yes | Yes |
| | | 300 Kcmil to 6 AWG 150 to 16mm ² | No | Yes | | 300 Kcmil to 6 AWG 150 to 16mm ² | No | Yes |
| | | screws fully opened | N/A | No | | screws fully opened | N/A | No |
| | | no wire in hole | No | N/A | | no wire in hole | No | N/A |