

UL489 or UL1077?

What are your Circuit Protection Requirements?

An understanding of circuit types and circuit protection products is critical to ensure their proper application.
See NEC Sections 100, 430 and 409 for definitions.

The proper sizing of an overcurrent protection device is the responsibility of the customer and should be determined using the application standards of the NEC (National Electric Code), CEC (Canadian Electrical Code) or other applicable standards. Per fine print note of 2008 NEC Section 100 "A current in excess of rating may be accommodated by certain equipment and conductors for a given set of conditions. Therefore, the rules for overcurrent protection are specific for particular situations."

UL489 Branch Protection



UL1077 Supplementary Protection



What You Need to Know and Look For In Specifications

Certifications – Standards – Acceptance

UL489 Branch Protection

- UL489 Listed or Recognized
- CSA C22.2 No. 5
- International ratings available depending on breaker type

UL1077 Supplementary Protection

- UL Recognized under UL1077
- CSA 22.2 No. 285
- IEC 60947-2 or IEC 898

Function

- Opens automatically on Overload and Short Circuit when properly applied within its ratings
- Protects wire and cable against Overload and Short Circuit
- Opens automatically on Overload and Short Circuit
- Provides additional equipment protection where branch circuit protection is already provided or not required
- Not suitable for the protection of branch circuit conductors

Applications

- Branch circuit protection in control panels, panelboards, switchboards and motor control centers
- Motor overload and motor short circuit protection (UL489 Recognized motor circuit protectors) for control panels and motor control centers
- Used within appliances or other electrical equipment such as control circuits, control power transformers, relays, PLC I/O points and lighting circuits
- Ideal replacement for fuses that are applied as supplementary protection

Features

- Bolted down or DIN-rail mounted
- External handle mechanisms available
- Field mounted accessories
- Stand alone branch circuit protection
- Various levels of protection (curve type)
- High voltage and interruption levels (up to 100 kAIC @ 480V)
- DIN-Rail mounted
- Field mounted accessories
- Current limiting
- Various levels of protection (curve type)
- 10 kAIC @ 240 VAC
- 6 kAIC @ 277 VAC and 5 kAIC @ 480 VAC
- 10 kAIC @ 65 VDC

kAIC = thousands of Amps interrupt capacity

Summary

A Supplementary Protector can't Be used for Branch Circuit Protection.
Understanding the difference between Branch Circuit Protection and Supplementary Protection helps to ensure their proper use.

Edison Fuses – HCTR Current Limiting Class CC



Features

- Branch circuit rated for 600 VAC
- Compact dimensions
- Time-delay design allows closer sizing for inductive loads such as control transformers and solenoids

Applications

- Primary protection for our PH series of control power transformers. See our complete selection listed at the end of this catalog section.

HCTR Specifications

Time-Delay

Voltage Rating: HCTR - 600 VAC

Ampere Rating: 0.25 - 30 Amps

Interrupting Rating:
200,000 RMS Symmetrical Amps

Current Limiting: Class CC Fuse

Agency Approvals

- UL Listed, Class CC, Guide JDDZ, File E162363
- CSA Certified HRCI-MISC per C22.2, No. 248.4
- CE Compliant

HCTR Current Limiting Class CC Fuses				
Part Number	AMP Rating	Pcs/Pkg	Package Weight	Price
HCTR-25	0.25	10	0.2 lb	<-->
HCTR-5	0.5			<-->
HCTR-75	0.75			<-->
HCTR1	1			<-->
HCTR1-25	1.25			<-->
HCTR1-5	1.5			<-->
HCTR2	2			<-->
HCTR2-5	2.5			<-->
HCTR3	3			<-->
HCTR3-5	3.5			<-->
HCTR4	4			<-->
HCTR5	5			<-->
HCTR6	6			<-->
HCTR7-5	7.5			<-->
HCTR8	8			<-->
HCTR10	10			<-->
HCTR15	15	<-->		
HCTR20	20	<-->		
HCTR25	25	<-->		
HCTR30	30	<-->		

DIMENSIONS		
Amps	Ferrule (in)	Length (in)
0.25 - 30	13/32	1-1/2

CROSS REFERENCE			
EDISON	BUSSMANN	GOULD	LITTELFUSE
HCTR	FNQ-R	ATQR	KLDR

Characteristic Curves

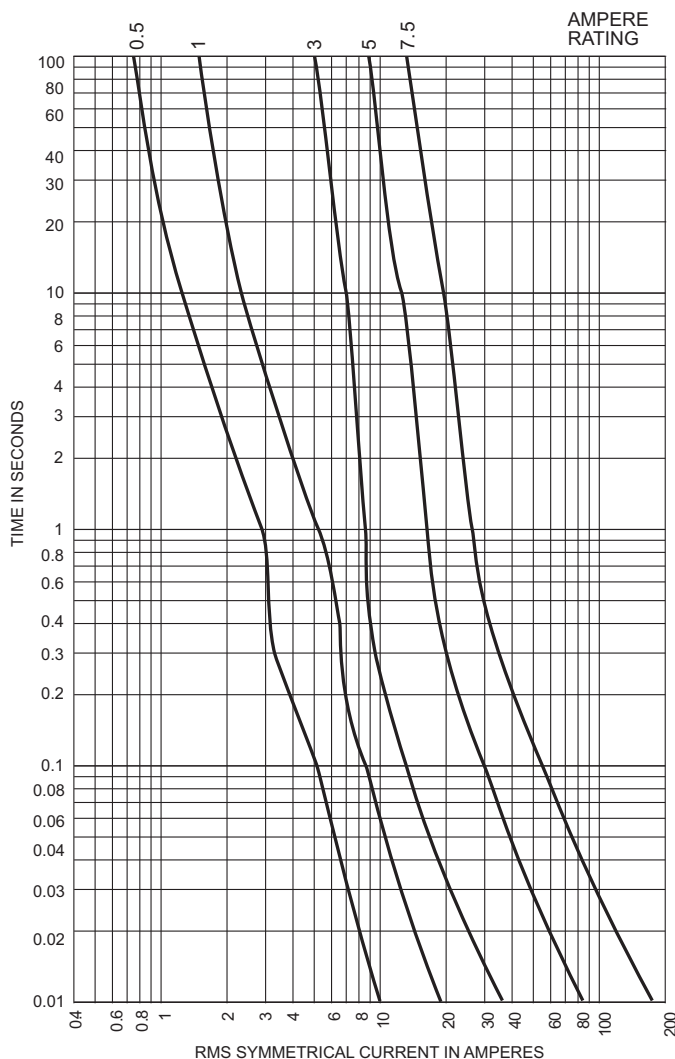

Edison Fuses – Selection Guide

Line Overview

The Edison family of fuses, fuse blocks and fuse holders is divided into two classes:

1. Current Limiting: Class CC, Class J, Class RK, Class T
2. General Purpose: Class M Midget and Small Dimension

The fuse selection guide below is a general summary of the specifications included for each fuse type. This selection guide does not include the many variables that can exist for specific situations such as local codes, unusual temperature, or other operating conditions. When selecting fuses, be sure to comply with any applicable PUBLIC SAFETY standards that apply to Overcurrent Protection Devices (OPD).

Edison Fuses Selection Guide and General Specifications											
Description	Current Limiting										
	Class J		Class RK5		Class RK1		Class T		Class CC		
Fuse Type	Fast-Acting	Time-Delay	Time-Delay				Extremely Fast-Acting	Fast-Acting	Time-Delay		
Part Number	JHL	JDL	ECNR	ECSR	LENRK	LESRK	TJN	TJS	HCLR	HCTR	EDCC
Voltage Rating	600 VAC 450 VDC	600 VAC 300 VDC*	250 VAC 125 VDC* (1–200A) 250 VDC* (201–600A)	600 VAC 300 VDC*	250 VAC 125 VDC* (10–60A) 250 VDC* (70–600A)	600 VAC 300 VDC*	300 VAC 160 VDC (15–600A)	600 VAC	600 VAC 300 VDC (15–20A)	600 VAC	600 VAC 300 VDC (0.5–2.25A) (20–30A)
Amp Rating	1 to 600		1 to 600	3 to 600	10 to 600	5 to 600	1 to 600		0.5 to 30	0.25 to 30	0.5 to 30
Interrupting Rating	200,000 RMS Symmetrical Amps										
Current Limiting	Class J		Class RK5		Class RK1		Class T		Class CC		
Agency Approvals	UL Listed Class J Guide JDDZ File E162363 CSA Certified HRCI-J per C22.2, No. 248.8 File 700489 RoHS compliant	UL Listed Class J Guide JDDZ File E162363 CSA Certified HRCI-J per C22.2, No. 248.8 File 700489	UL Listed, Class RK, Guide JDDZ, File E162363 CSA Certified HRCI-R per C22.2, No. 248.12, File 700489 (LENRK CSA File 053787)				UL Listed, Class T, Guide JDDZ, File E162363 CSA Certified HRCI-T per C22.2, No. 248.12, File 53787, Class 1422-02 & 1422-82		UL Listed to 248.4, Class CC, Guide JDDZ, File E162363, CSA certified HRCI-MISC per C22.2 No. 248.4, File 700489		
Dimensions	See product specification pages.								ferrule (in): 13/32, length (in): 1-1/2		
* Self-certified DC ratings											

Edison Fuses Selection Guide and General Specifications												
Description	General Purpose – Midget				General Purpose – Small Dimension Electronic							
	Fast-Acting		Time-Delay		Fast-Acting Ceramic	Fast-Acting Glass		Medium Time-Delay Glass	Time-Delay Ceramic	Time-Delay Glass	Fast-Acting Glass	Time-Delay Glass
Part Number	MCL	MOL	MEQ	MEN	ABC	AGC	GMA	GMC	MDA	MDL	S500	S506
Voltage Rating	600 VAC	250 VAC	500 VAC	250 VAC	250 VAC (0.5 to 20A) 125VAC: (25 to 30A) 125VDC	250VAC: (0.1 to 10A) 32VAC: (15 to 30A)	250VAC (0.063 - 3A) 125VAC (4 - 15A)	250VAC (0.5 - 3A) 125VAC (4 - 10A)	250VAC (0.0625 to 8A) 32VAC: (10 to 20A)	250VAC	250VAC	250VAC
Amp Rating	0.5 to 50	0.5 to 30	0.25 to 30	0.5 to 30	0.5 to 30	0.10 to 30	0.063 to 15	0.5 to 10	0.5 to 20	0.0625 to 20	0.032 to 10	0.25 to 6.3
Interrupting Rating	100,000 RMS Amps	10,000 RMS Amps			See specifications table on product pages							
Current Limiting	N/A				N/A							
Agency Approvals	UL Listed to 248.14, File E162443 CSA Cert. C22.2 Part 59.2, LR 700489				UL Listed standard 248-14 UL Listed Guide and File nos. (ABC 0.25-20 A): (AGC 1/100-10 A) JDYX and E19180 UL Recognition Guide and File nos. (ABC 20-30A): (AGC 11-30) JDYX2 and E19180 CSA Certification Record No: 053787 C 000 and Class No: 1422 01 and 1422 30	Designed to UL/CSA 248-14 UL Listed, Guide JDYX, File E19180 63mA-6A UL Recognition, Guide JDYX2, File E19180, 7A-15A CSA Certified, File 053787_C_000, 63mA-6A Class 1422-01		UL Listed standard 248-14 UL Listed Card: MDA 2/10-20A , MDL 1/16-8A (Guide JDYX, File E19180 UL Recognized Card: MDA 25-30A MDL 9-30A (Guide JDYX2, File E19180) CSA Certification Card: MDA 2/10-15A (Class No. 1422-01)		UL Recognized Guide JDYX2, File E19180 Semko Approval VDE Approval BSI Approval IMQ Approval RoHS compliant		
Dimensions	ferrule (in): 13/32 length (in): 1-1/2				1/4" x 1-1/4", (6.3mm x 32mm)		0.197" x 0.788" (5mm x 20mm)		1/4" x 1-1/4", (6.3mm x 32mm)		0.197" x 0.788" (5mm x 20mm)	

Fuse Terminal Blocks

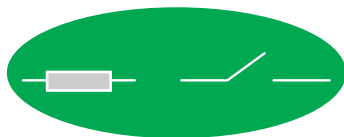

Fuse blocks are available for 1/4", 5 mm, Class CC and midsize fuses, either with or without a blown fuse LED. LED fuse blocks are polarity sensitive. The hinge side is positive.



DN-F6 Series: EURO S10-H



DN-F6L Series: EURO S10-H



DN-F10 Series: EURO S4LH



DN-F10L Series: EURO S4LH

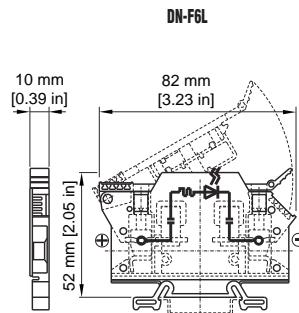
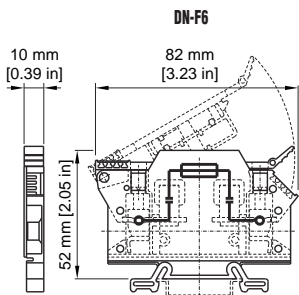

	Part Number	Pcs/Pkg	Price/Pkg	Part Number	Pcs/Pkg	Price/Pkg	Part Number	Pcs/Pkg	Price/Pkg	Part Number	Pcs/Pkg	Price/Pkg
Gray Term Blk	DN-F6	25	<-->	-	-	-	DN-F10	50	<-->	-	-	-
12-24VAC/DC*	-	-	-	DN-F6L24	10	<-->	-	-	-	DN-F10L24	10	<-->
110VAC/DC*	-	-	-	DN-F6L110	10	<-->	-	-	-	DN-F10L110	10	<-->
220VAC/DC*	-	-	-	DN-F6L220	10	<-->	-	-	-	DN-F10L220	10	<-->

Fuse Terminal Blocks Specifications

UL Approval**	600V	30A	20-6 AWG	600V	30A	20-6 AWG	300V	15A	24-10 AWG	300V	15A	24-10 AWG
CSA Approval	600V	30A	18-6 AWG	600V	30A	18-6 AWG	300V	8A	18-12 AWG	300V	8A	18-12 AWG
VDE Approval	750V	8A	-	750V	8A	-	500V	8A	4mm ²	500V	8A	4mm ²
CE Conformity	CE 23/20, CE 23/21			CE 23/20, CE 23/21			CE 23/20, CE 23/21			CE 23/20, CE 23/21		
Agency File #	E179129, LR84816			E179129, LR84816			E179129, LR84816			E179129, LR84816		
Wire Strip Length	0.47" (12mm)			0.47" (12mm)			0.39" (10mm)			0.39" (10mm)		
Tightening Torque	18.0 lb-in (2.0Nm)			18.0 lb-in (2.0Nm)			5.5 lb-in (0.6Nm)			5.5 lb-in (0.6Nm)		
Density	30 pcs./ft. (100/m)			30 pcs./ft. (100/m)			30 pcs./ft. (100/m)			30 pcs./ft. (100/m)		
Fuse Size (not supplied)	1 1/4" X 1/4"			1 1/4" X 1/4"			5x20mm-5x25mm			5x20mm-5x25mm		
Indicator Type	Non-indicating			LED blown fuse indicator			Non-indicating			LED blown fuse indicator		
Operating Temperature	Ambient air temperature: -13°F to 104°F (-25°C to 40°C) Relative humidity: 50% max at 104°F (40°C); 90% max at 68°F (20°C)											
SCCR	10 kA per Table SB4.1, 2009, UL 508A, Maximum short circuit current rating for unmarked components											
Notes:	* Working voltage			** For copper wire only								

Accessories

	Part Number	Pcs/Pkg	Price/Pkg
35 mm DIN Rail	DN-R35S1 (7.5 mm) or DN-R35HS1 (15 mm)	10	various
	DN-R35S1-2 (7.5 mm) or DN-R35HS1-2 (15 mm)	2	various
End Bracket	DN-EB35	50	<-->
	DN-EB35MN	20	<-->
	DN-EB35-A or DN-QEB35	50	various
	DN-EB35-A-10 or DN-QEB35-10	10	various
End Cover	Included		
Marking Tags	Included		
Angled Support Bracket	DN-L*/DN-LT** series	500/100	various
	DN-ASB1	50	<-->

Notes: * On lever arm, ** On terminal body

For more information on accessories, see the DINnectors Accessories section of this chapter.

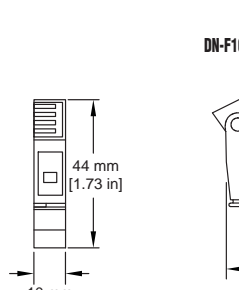
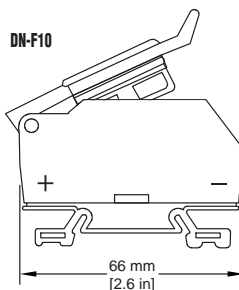

Note: DN-F6 series fuse holders will accommodate the following AutomationDirect fuses: ABC, AGC, MDA and MDL.

DN-F10 series fuse holders will accommodate the following AutomationDirect fuses: GMA, GMC, S500, and S506.

Edison Fuses – Fuse Holders

Features

- New design – shipping since 4th Quarter 2009
- Finger-safe protection
- Optional “open-fuse” indication - minimum 90 VAC required for illumination
- Polyester material is UL 94V-0 rated, self-extinguishing
- Multi-phase connections available for ganging poles
- Mounts on 35mm DIN rail (DN-R35S1)
- CE marking

Part number guide for CH series fuse holders: M = Midget class; CC = CC class; 1D, 2D, 3D = 1, 2, and 3 pole configurations; I = with NEON indicator; -1 = quantity of 1.



Agency Approvals Class CC

- cULus Listed, Guide IZLT, File E14853
- IEC 60269-2
- IEC 60947-3
- CE Compliant

Agency Approvals Midget

- cURus Recognized, Guide IZLT2, File E14853
- IEC 60269-2
- IEC 60947-3
- CE Compliant

Application

CHM: Edison MCL, MOL, MEQ, MEN midget fuses.
CHCC: Edison HCLR, HCTR, EDCC fuses

Modular Fuse Holder Selection Table														
Series Size	Max Voltage & Current	IEC	cULus	cURus	Phase Configuration	No. of 17.5mm Modules*	Fuse Holder Without Indication	Box Qty.	Pkg. Wt. (lbs.)	Price	Fuse Holder with NEON Indication	Box Qty.	Pkg. Wt. (lbs.)	Price
CHM Midget Class	UL/CSA 600 VAC/DC, 30A (3 Watt)	• †	•	•	1 pole	1	CHM1D-1	1	0.14	<--->	CHM1DI-1	1	0.14	<--->
							CHM1D	12	1.8	<--->	CHM1DI	12	1.8	<--->
							CHM2D-1	1	0.3	<--->	CHM2DI-1	1	0.3	<--->
	IEC 690 VAC, 32A	• †	•	•	2 pole	2	CHM2D	6	1.8	<--->	CHM2DI	6	1.8	<--->
							CHM3D-1	1	0.4	<--->	CHM3DI-1	1	0.4	<--->
							CHM3D	4	1.8	<--->	CHM3DI	4	1.8	<--->
CHCC Class CC	UL/CSA 600VAC/DC, 30A	††	•	•	1 pole	1	CHCC1D-1	1	0.14	<--->	CHCC1DI-1	1	0.14	<--->
							CHCC1D	12	1.8	<--->	CHCC1DI	12	1.8	<--->
							CHCC2D-1	1	0.3	<--->	CHCC2DI-1	1	0.3	<--->
		††	•	•	2 pole	2	CHCC2D	6	1.8	<--->	CHCC2DI	6	1.8	<--->
							CHCC3D-1	1	0.4	<--->	CHCC3DI-1	1	0.4	<--->
							CHCC3D	4	1.8	<--->	CHCC3DI	4	1.8	<--->

CHCC and CHM Wire Range and Torque		
Wire Range	Conductor Type (75 degrees C, Cu Wire Only) / Number of Conductors	Max. Torque
0.8 - 4 mm ² (18 - 12 AWG)	Solid, Stranded / Single	2.3 Nm (20 lb-in)
5.0 mm ² (10 AWG)	Solid / Single	2.8 Nm (25 lb-in)
5.0 - 8.0 mm ² (10 - 8 AWG)	Stranded / Single	
0.8 - 2.0 mm ² (18 - 14 AWG)	Solid / Dual	2.8 Nm (25 lb-in)
0.8 - 5.0 mm ² (18 - 10 AWG)	Stranded / Dual	

*Holder width as compared to standard 17.5 mm module (1 = 17.5 mm, 2 = 35 mm, 3 = 52.5 mm) † cUL Recognized (SCCR: 10 kA) †† cUL Listed (SCCR: 200 kA)
Note: To add additional poles, see multi-pole connection kit JV-L in Accessories. Retired accessories AL-D and CH810-HP will not work with new design.

Fuse Holders Dimensions

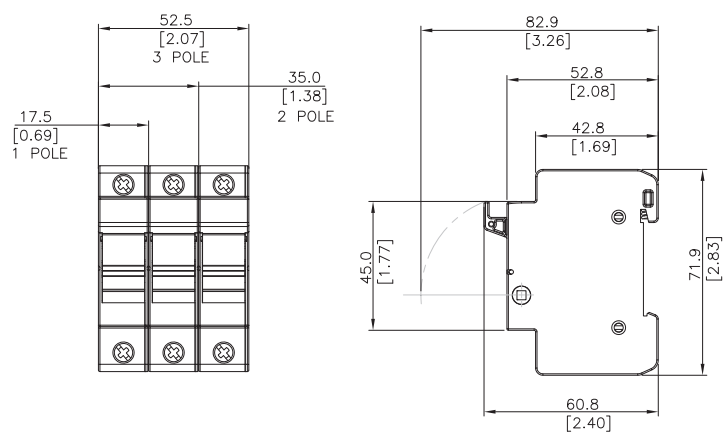

DIN Rail Removal

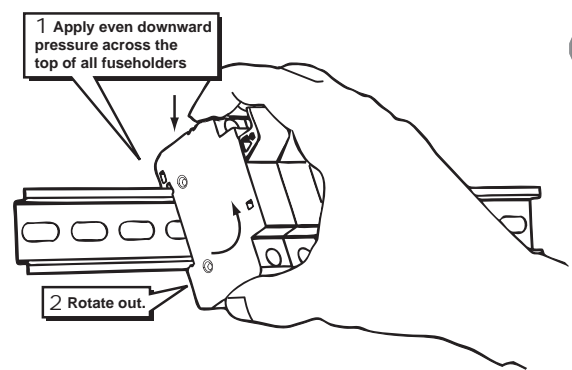

Edison Fuses – Fuse Blocks

Description

These panel-mount fuse blocks are for use with Class CC Fuses (Edison EDCC, HCTR and HCLR).



Specifications

Terminal type: Pressure plate with quick connect terminal

Base: Thermoplastic

Clips: Bright tin-plated bronze

UL Flammability: 94V-0

Ratings: 600 VAC, 30 Amps

Agency Approvals

- UL listed to 512, Guide IZLT, File 14853
- CSA C22.2 No. 39 Class 6225-01, File LR47235
- CE Compliant

BC Series Fuseblocks						
Part Number	Amps	Poles	AWG	Pcs/Pkg	Wt. (lbs.)	Price
BC6031PQ	0.1 to 30	1	18 - 8	10	0.1	<--->
BC6032PQ		2		8	0.16	<--->
BC6033PQ		3		6	0.22	<--->

CROSS REFERENCE				
EDISON	OLD EDISON	BUSSMANN	GOULD	LITTELFUSE
BC6031PQ	EMR631-77	BC6031PQ	30321R	L60030C-1PQ
BC6032PQ	EMR632-77	BC6032PQ	30322R	L60030C-2PQ
BC6033PQ	EMR633-77	BC6033PQ	30323R	L60030C-3PQ

Description

These panel-mount fuse blocks are for use with any 13/32" x 1-1/2" Class M Fuses (Edison MCL, MEQ, MEN and MOL).



Specifications

Terminal type: Pressure plate with quick connect terminal

Base: Thermoplastic

Clips: Bright tin-plated bronze

UL Flammability: 94V-0

Ratings: 600 VAC, 30 Amps

Agency Approvals

- UL Recognized to 512, Guide IZLT2, File E14853
- CSA C22.2, No.39, Class 6225-01, File 47235

BM Series Fuseblocks						
Part Number	Amps	Poles	AWG	Pcs/Pkg	Wt. (lbs.)	Price
BM6031PQ	0.1 to 30	1	18 - 8	10	0.1	<--->
BM6032PQ		2		8	0.16	<--->
BM6033PQ		3		6	0.22	<--->

CROSS REFERENCE				
EDISON	OLD EDISON	BUSSMANN	GOULD	LITTELFUSE
BM6031PQ	EM631-44	BM6031PQ	30321	L60030M-1PQ
BM6032PQ	EM632-44	BM6032PQ	30322	L60030M-2PQ
BM6033PQ	EM633-44	BM6033PQ	30323	L60030M-3PQ

Edison Fuses – Fuse Block Dimensions

CC Class Dimensions -

inches(mm)

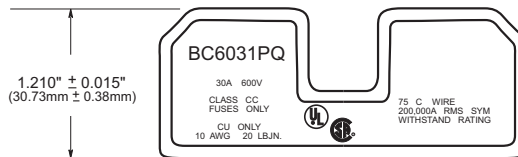
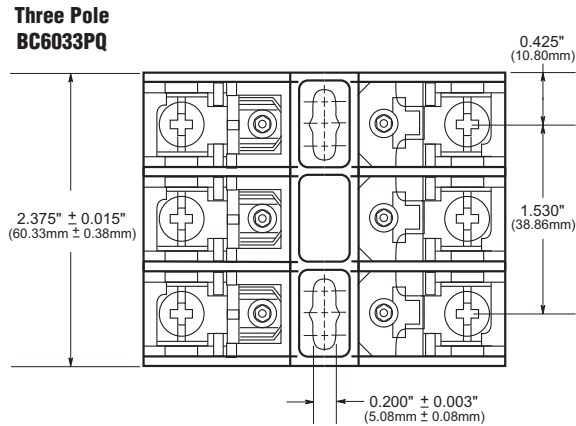
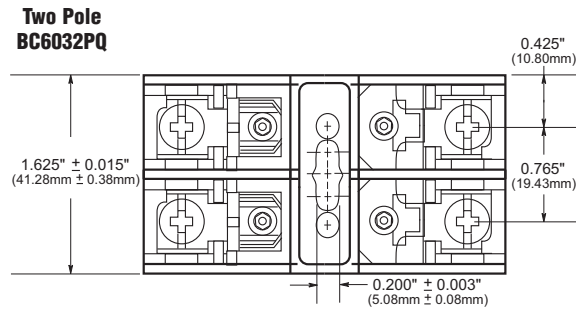
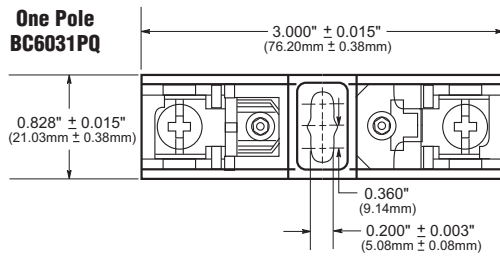

M Class Dimensions

inches(mm)

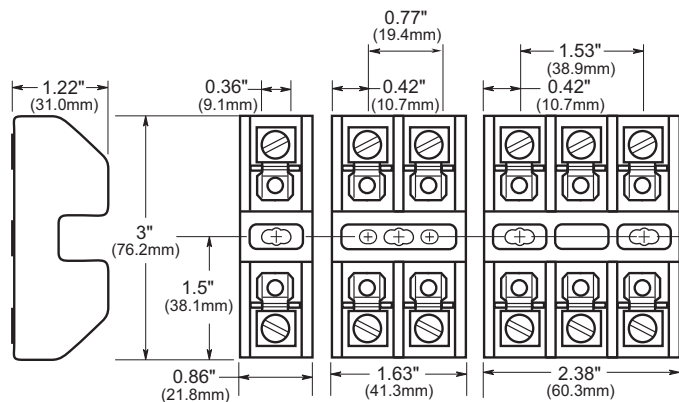

**One Pole
BM6031PQ**

**Two Pole
BM6032PQ**

**Three Pole
BM6033PQ**

Edison Fuses – Accessories



FP2



JV-L

Accessories			
Part Number	Description	Pcs/Pkg	Price
FP-2	Fuse puller for fuse dia. 13/32" - 13/16". Fuse type: 0-60A, 250V; 0-30A, 600V	1	<--->
JV-L* (Not Field Installable)	Multi-pole connection kit to connect new design multiple Class CC and Midget Class fuse holders together. Kit consists of 6 connectors and 3 handle pins to connect up to 4 fuse holders.		<--->

Note: Will not work with retired design fuse holders shipped before November 1, 2009.

**Roll pin punch or installation tool is required to install handle pins (Tool not sold by Automationdirect.com).*

Handle Pin Dimensions
 Diameter = 0.0625 in [1.58 mm]
 Length = 0.632 in [16.07 mm]

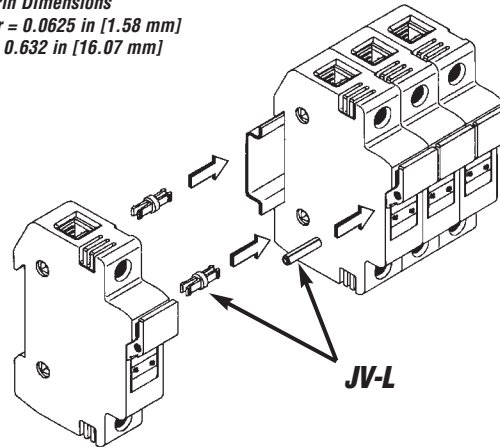

Edison Cross Reference Guide

CROSS REFERENCE GUIDE By manufacturers type reference or series number. Ampere ratings must be added for ordering purposes.								
FUSE TYPE		VOLT	EDISON	BRUSH/ DORMAN	BUSSMANN	MERSEN / GOULD	GEC/CEFCO	LITTELFUSE
UL CLASS CURRENT LIMITING FUSES (CSA CLASS)								
CC (HRCI-CC)	Time-Delay	600	EDCC	–	LP-CC	ATDR	–	CCMR
	Time-Delay	600	HCTR	–	FNQ-R	ATQR	–	KLDR
	Fast-Acting	600	HCLR	HCLR	KTK-R	ATMR	CTK-R	KLKR
RK1	Time-Delay Dual Element	250	LENRK	–	LPN-RK-SP	A2DR	–	LLNRK
		600	LESRK	–	LPS-RK-SP	A6DR	–	LLSRK
RK5	Time-Delay Dual Element	250	ECNR	–	FRN-R	TR	–	FLNR
		600	ECSR	–	FRS-R	TRS	–	FLSR
J	Time-Delay Dual Element	600	JDL	–	LPJ	AJT	–	JTD
	High-Speed AC Drive	600	JHL	–	DFJ	HSJ	–	–
T	Extremely Fast-Acting	300	TJN	–	JJN	A3T	–	JLLN
		600	TJS	–	JJS	A6T	–	JLLS
UL CLASS GENERAL PURPOSE FUSES								
Midget	Fast-Acting	600	MCL	MCL	KTK	ATM	CTK	KLK
		250	MOL	MOL	BAF/BAN	OTM	–	BLF
	Time-Delay	500	MEQ	MEQ	FNQ	ATQ	–	FLQ
		250	MEN	MEN	FNM	TRM	–	FLM
1/4"x1/4" Ceramic	Fast-Acting	250/125	ABC	ABC	ABC	GAB	–	314
		1/4"x1/4"Glass	250/32	AGC	AGC	AGC	GGC	–
1/4"x1/4" Ceramic	Time-Delay	250	MDA	MDA	MDA	–	–	326
		1/4"x1/4"Glass	250/32	MDL	MDL	MDL	GDL	–
5x20 mm Glass	Fast-Acting	250/125	GMA	GMA	GMA	GGM	–	235
	Medium Time-Delay	250/125	GMC	GMC	GMC	GSC	–	–
5x20 mm Glass	Fast-Acting	250	S500	BDB	GDB	GSB	–	217
	Time-Delay	250	S506	BDC	GDC	GDG	–	218
Fuse Puller								
Fuse Puller FP-2		–	old - 38072 new - FP-2	–	FP-2	–	–	–