

UL489 or UL1077?

What are your Circuit Protection Requirements?

An understanding of circuit types and circuit protection products is critical to ensure their proper application.
See NEC Sections 100, 430 and 409 for definitions.

The proper sizing of an overcurrent protection device is the responsibility of the customer and should be determined using the application standards of the NEC (National Electric Code), CEC (Canadian Electrical Code) or other applicable standards. Per fine print note of 2008 NEC Section 100 "A current in excess of rating may be accommodated by certain equipment and conductors for a given set of conditions. Therefore, the rules for overcurrent protection are specific for particular situations."

UL489

Branch Protection



UL1077

Supplementary Protection



What You Need to Know and Look For In Specifications

Certifications – Standards – Acceptance

UL489

Branch Protection

- UL489 Listed or Recognized
- CSA C22.2 No. 5
- International ratings available depending on breaker type

UL1077

Supplementary Protection

- UL Recognized under UL1077
- CSA 22.2 No. 285
- IEC 60947-2 or IEC 898

Function

- | | |
|--|---|
| <ul style="list-style-type: none"> • Opens automatically on Overload and Short Circuit when properly applied within its ratings • Protects wire and cable against Overload and Short Circuit | <ul style="list-style-type: none"> • Opens automatically on Overload and Short Circuit • Provides additional equipment protection where branch circuit protection is already provided or not required • Not suitable for the protection of branch circuit conductors |
|--|---|

Applications

- | | |
|--|---|
| <ul style="list-style-type: none"> • Branch circuit protection in control panels, panelboards, switchboards and motor control centers • Motor overload and motor short circuit protection (UL489 Recognized motor circuit protectors) for control panels and motor control centers | <ul style="list-style-type: none"> • Used within appliances or other electrical equipment such as control circuits, control power transformers, relays, PLC I/O points and lighting circuits • Ideal replacement for fuses that are applied as supplementary protection |
|--|---|

Features

- | | |
|--|--|
| <ul style="list-style-type: none"> • Bolted down or DIN-rail mounted • External handle mechanisms available • Field mounted accessories • Stand alone branch circuit protection • Various levels of protection (curve type) • High voltage and interruption levels (up to 100 kAIC @ 480V) | <ul style="list-style-type: none"> • DIN-Rail mounted • Field mounted accessories • Current limiting • Various levels of protection (curve type) • 10 kAIC @ 240 VAC • 6 kAIC @ 277 VAC and 5 kAIC @ 480 VAC • 10 kAIC @ 65 VDC |
|--|--|

kAIC = thousands of Amps interrupt capacity

Summary

A Supplementary Protector can't Be used for Branch Circuit Protection.
Understanding the difference between Branch Circuit Protection and Supplementary Protection helps to ensure their proper use.

Edison Fuses – Modular Fuse Holders for Class J Fuses



CH30J1



CH30J2I



CH30J3

Description

- Choice of LED indicator or non-indicating fuse holder
- Comes in standard 1-, 2- and 3-Pole ganged assemblies where all fuses are extracted simultaneously
- Meets requirements of IEC 60529 for IP-20 finger safe rating
- 35 mm DIN rail and chassis (6-32 UNC Pan Head recommended) mounting features
- Fuseholder wire ports dual wire rated from 18 to 3 AWG

Specifications

Construction: Thermoplastic, with tin-plated copper clip
UL Flammability: 94V-0

Voltage Ratings: 600 Volts AC

Ampere Ratings: 1 - 60 Amps

Interrupting Rating: 200,000 RMS Symmetrical Amps

Minimum Indicating Voltage (neon lamp): 90 Volts

Nominal Operating Current (neon lamp): 34 mA (460 VAC)

Agency Approvals

- Listed UL 512, Guide IZLT, File E14853
- CSA Certified per C22.2 Nos. 39 Class 6225-01, File LR47235
- CE compliance for the European Union Low Voltage Directive

CH Series Modular Fuse Holders for Class J Fuses							
Amp Rating	Part Number	Type	Poles	Maximum Wire Size	Pcs/Pkg	Weight (lbs.)	Price
30A	CH30J1	Easy ID window	1	18 -1 AWG Single 18 -3 AWG Dual 75°C	6	2.8	<--->
	CH30J2	Easy ID window	2		3		<--->
	CH30J3	Easy ID window	3		2		<--->
	CH30J1I	Neon indicator	1		6		<--->
	CH30J2I	Neon indicator	2		3		<--->
	CH30J3I	Neon indicator	3		2		<--->
60A	CH60J1	Easy ID window	1	18 -1 AWG Single 18 -3 AWG Dual 75°C	6	3.4	<--->
	CH60J2	Easy ID window	2		3		<--->
	CH60J3	Easy ID window	3		2		<--->
	CH60J1I	Neon indicator	1		6		<--->
	CH60J2I	Neon indicator	2		3		<--->
	CH60J3I	Neon indicator	3		2		<--->

Dimensions

Dimension	CH30J in (mm)	CH60J in (mm)
A	1.28 (32.5)	1.58 (40.0)
B	2.56 (65.0)	3.16 (80.0)
C	3.84 (97.5)	4.72 (120.0)
D	4.59 (116.6)	4.88 (124.0)
E	2.83 (71.8)	3.31 (84.1)
F	3.56 (90.4)	3.85 (97.9)
G	1.28 (32.5)	1.58 (40.0)
H	0.18 (4.44)	0.18 (4.44)

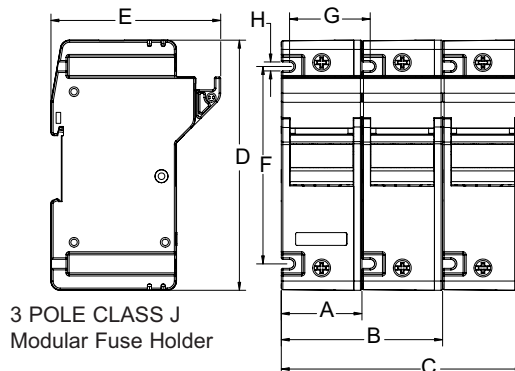

Edison Fuses – Fuse Holders

Features

- New design – shipping since 4th Quarter 2009
- Finger-safe protection
- Optional “open-fuse” indication - minimum 90 VAC required for illumination
- Polyester material is UL 94V-0 rated, self-extinguishing
- Multi-phase connections available for ganging poles
- Mounts on 35mm DIN rail (DN-R35S1)
- CE marking

Part number guide for CH series fuse holders: M = Midget class; CC = CC class; 1D, 2D, 3D = 1, 2, and 3 pole configurations; I = with NEON indicator; -1 = quantity of 1.



Agency Approvals Class CC

- cULus Listed, Guide IZLT, File E14853
- IEC 60269-2
- IEC 60947-3
- CE Compliant

Agency Approvals Midget

- cURus Recognized, Guide IZLT2, File E14853
- IEC 60269-2
- IEC 60947-3
- CE Compliant

Application

CHM: Edison MCL, MOL, MEQ, MEN midget fuses.

CHCC: Edison HCLR, HCTR, EDCC fuses

Modular Fuse Holder Selection Table													CHCC and CHM Wire Range and Torque				
Series Size	Max Voltage & Current	IEC	cULus	cURus	Phase Configuration	No. of 17.5mm Modules*	Fuse Holder Without Indication	Box Qty.	Pkg. Wt. (lbs.)	Price	Fuse Holder with NEON Indication	Box Qty.	Pkg. Wt. (lbs.)	Price	Wire Range	Conductor Type (75 degrees C, Cu Wire Only) / Number of Conductors	Max. Torque
CHM Midget Class	UL/CSA 600 VAC/DC, 30A (3 Watt)	•	†	•	1 pole	1	CHM1D-1	1	0.14	<--->	CHM1DI-1	1	0.14	<--->	0.8 - 4 mm ² (18 - 12 AWG)	Solid, Stranded / Single	2.3 Nm (20 lb-in)
					2 pole	2	CHM2D-1	1	0.3	<--->	CHM2DI-1	1	0.3	<--->			
					3 pole	3	CHM3D-1	1	0.4	<--->	CHM3DI-1	1	0.4	<--->			
	IEC 690 VAC, 32A	•	†	•	1 pole	1	CHM1D	12	1.8	<--->	CHM1DI	12	1.8	<--->	5.0 mm ² (10 AWG)	Solid / Single	2.8 Nm (25 lb-in)
					2 pole	2	CHM2D	6	1.8	<--->	CHM2DI	6	1.8	<--->			
					3 pole	3	CHM3D	4	1.8	<--->	CHM3DI	4	1.8	<--->			
CHCC Class CC	UL/CSA 600VAC/DC, 30A	††	•	•	1 pole	1	CHCC1D-1	1	0.14	<--->	CHCC1DI-1	1	0.14	<--->	0.8 - 2.0 mm ² (18 - 14 AWG)	Solid / Dual	2.8 Nm (25 lb-in)
					2 pole	2	CHCC2D-1	1	0.3	<--->	CHCC2DI-1	1	0.3	<--->			
					3 pole	3	CHCC3D-1	1	0.4	<--->	CHCC3DI-1	1	0.4	<--->			
	UL/CSA 600VAC/DC, 30A	††	•	•	1 pole	1	CHCC1D	12	1.8	<--->	CHCC1DI	12	1.8	<--->	0.8 - 5.0 mm ² (18 - 10 AWG)	Stranded / Dual	2.8 Nm (25 lb-in)
					2 pole	2	CHCC2D	6	1.8	<--->	CHCC2DI	6	1.8	<--->			
					3 pole	3	CHCC3D	4	1.8	<--->	CHCC3DI	4	1.8	<--->			

*Holder width as compared to standard 17.5 mm module (1 = 17.5 mm, 2 = 35 mm, 3 = 52.5 mm) † cUL Recognized (SCCR: 10 kA) †† cUL Listed (SCCR: 200 kA)
 Note: To add additional poles, see multi-pole connection kit JV-L in Accessories. Retired accessories AL-D and CH810-HP will not work with new design.

Fuse Holders Dimensions

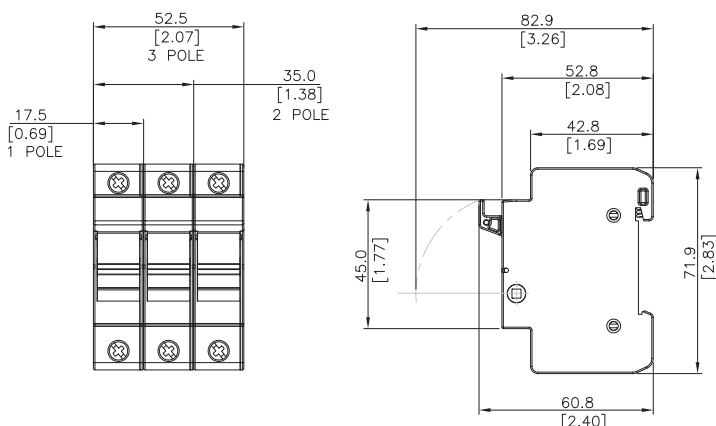

DIN Rail Removal

