

UL489 or UL1077?

What are your Circuit Protection Requirements?

An understanding of circuit types and circuit protection products is critical to ensure their proper application.
See NEC Sections 100, 430 and 409 for definitions.

The proper sizing of an overcurrent protection device is the responsibility of the customer and should be determined using the application standards of the NEC (National Electric Code), CEC (Canadian Electrical Code) or other applicable standards. Per fine print note of 2008 NEC Section 100 "A current in excess of rating may be accommodated by certain equipment and conductors for a given set of conditions. Therefore, the rules for overcurrent protection are specific for particular situations."

UL489 Branch Protection



UL1077 Supplementary Protection



What You Need to Know and Look For In Specifications

Certifications – Standards – Acceptance

UL489 Branch Protection

- UL489 Listed or Recognized
- CSA C22.2 No. 5
- International ratings available depending on breaker type

UL1077 Supplementary Protection

- UL Recognized under UL1077
- CSA 22.2 No. 285
- IEC 60947-2 or IEC 898

Function

- Opens automatically on Overload and Short Circuit when properly applied within its ratings
- Protects wire and cable against Overload and Short Circuit
- Opens automatically on Overload and Short Circuit
- Provides additional equipment protection where branch circuit protection is already provided or not required
- Not suitable for the protection of branch circuit conductors

Applications

- Branch circuit protection in control panels, panelboards, switchboards and motor control centers
- Motor overload and motor short circuit protection (UL489 Recognized motor circuit protectors) for control panels and motor control centers
- Used within appliances or other electrical equipment such as control circuits, control power transformers, relays, PLC I/O points and lighting circuits
- Ideal replacement for fuses that are applied as supplementary protection

Features

- Bolted down or DIN-rail mounted
- External handle mechanisms available
- Field mounted accessories
- Stand alone branch circuit protection
- Various levels of protection (curve type)
- High voltage and interruption levels (up to 100 kAIC @ 480V)
- DIN-Rail mounted
- Field mounted accessories
- Current limiting
- Various levels of protection (curve type)
- 10 kAIC @ 240 VAC
- 6 kAIC @ 277 VAC and 5 kAIC @ 480 VAC
- 10 kAIC @ 65 VDC

kAIC = thousands of Amps interrupt capacity

Summary

A Supplementary Protector can't Be used for Branch Circuit Protection.
Understanding the difference between Branch Circuit Protection and Supplementary Protection helps to ensure their proper use.

Edison Fuses – Extremely Fast-Acting Class T

EDISON TJN and TJS Class T fuses are extremely fast-acting fuses in a compact, space-saving size. These fuses are ideal as the main fuse protection for panel boards, load centers, meter stacks, and AC drives.

TJN/S Features

- Extremely current limiting
- No intentional time delay; opens quickly on overload
- Silver link construction provides superior component protection against fault currents
- Space saving dimensions

Applications

- Recommended for protection of non-inductive loads such as lighting and resistance-heating circuits
- Use to protect lower interrupting-rated circuit breakers when series rated with Class T fuses
- For motor protection, size at 300% FLC; provides short-circuit protection only
- Use for short-circuit protection of AC drives

Specifications

Voltage Rating: TJN: 300 VAC
TJS: 600 VAC

Ampere Ratings: 1–600 Amps

Interrupting Rating: 200,000
RMS Symmetrical Amps

Self-Certified Voltage Ratings
(DC):

TJN (15–600): 160 VDC

TJS (15–400): 300 VDC

Self-Certified Interrupting
Ratings (DC):

TJN (15–600): 20,000 Amps DC

TJS (15–400): 10,000 Amps DC

Current Limiting: Class T Fuse

Agency Approvals

- UL Listed, Class T, Guide JDDZ, File E162363
- CSA Certified HRCI-T per C22.2, No. 248.12, File # 53787
- CE
- REACH

T Series 300VAC Extremely Fast-Acting Fuses						T Series 600VAC Extremely Fast-Acting Fuses					
Part Number	AMP Rating	Rated Voltage	Pcs/Pkg	Package Weight	Price	Part Number	AMP Rating	Rated Voltage	Pcs/Pkg	Package Weight	Price
TJN1	1	300 VAC	10	0.12 lb	<-->	TJS1	1	600 VAC	10	0.33 lb	<-->
TJN1-1			1	0.02 lb	<-->	TJS1-1			1	0.02 lb	<-->
TJN3	3		10	0.12 lb	<-->	TJS3	3		10	0.33 lb	<-->
TJN3-1			1	0.02 lb	<-->	TJS3-1			1	0.02 lb	<-->
TJN6	6		10	0.12 lb	<-->	TJS6	6		10	0.33 lb	<-->
TJN6-1			1	0.02 lb	<-->	TJS6-1			1	0.02 lb	<-->
TJN10	10		10	0.12 lb	<-->	TJS10	10		10	0.33 lb	<-->
TJN10-1			1	0.02 lb	<-->	TJS10-1			1	0.02 lb	<-->
TJN15	15		10	0.12 lb	<-->	TJS15	15		10	0.33 lb	<-->
TJN15-1			1	0.02 lb	<-->	TJS15-1			1	0.02 lb	<-->
TJN20	20		10	0.12 lb	<-->	TJS20	20		10	0.33 lb	<-->
TJN20-1			1	0.02 lb	<-->	TJS20-1			1	0.02 lb	<-->
TJN25	25		10	0.12 lb	<-->	TJS25	25		10	0.33 lb	<-->
TJN25-1			1	0.02 lb	<-->	TJS25-1			1	0.02 lb	<-->
TJN30	30		10	0.12 lb	<-->	TJS30	30		10	0.33 lb	<-->
TJN30-1			1	0.02 lb	<-->	TJS30-1			1	0.02 lb	<-->
TJN35	35		10	0.23 lb	<-->	TJS35	35		10	0.82 lb	<-->
TJN35-1			1	0.03 lb	<-->	TJS35-1			1	0.03 lb	<-->
TJN40	40		10	0.23 lb	<-->	TJS40	40		10	0.82 lb	<-->
TJN40-1			1	0.03 lb	<-->	TJS40-1			1	0.03 lb	<-->
TJN45	45		10	0.23 lb	<-->	TJS45	45		10	0.82 lb	<-->
TJN45-1			1	0.03 lb	<-->	TJS45-1			1	0.03 lb	<-->
TJN50	50		10	0.23 lb	<-->	TJS50	50		10	0.82 lb	<-->
TJN50-1			1	0.03 lb	<-->	TJS50-1			1	0.03 lb	<-->
TJN60	60	10	0.23 lb	<-->	TJS60	60	10	0.82 lb	<-->		
TJN60-1		1	0.03 lb	<-->	TJS60-1		1	0.03 lb	<-->		
TJN70	70	5	0.36 lb	<-->	TJS70	70	5	0.51 lb	<-->		
TJN70-1		1	0.11 lb	<-->	TJS70-1		1	0.11 lb	<-->		
TJN80	80	5	0.36 lb	<-->	TJS80	80	5	0.51 lb	<-->		
TJN80-1		1	0.11 lb	<-->	TJS80-1		1	0.11 lb	<-->		
TJN90	90	5	0.36 lb	<-->	TJS90	90	5	0.51 lb	<-->		
TJN90-1		1	0.11 lb	<-->	TJS90-1		1	0.11 lb	<-->		
TJN100	100	5	0.36 lb	<-->	TJS100	100	5	0.51 lb	<-->		
TJN100-1		1	0.11 lb	<-->	TJS100-1		1	0.11 lb	<-->		
TJN110	110	1	0.14 lb	<-->	TJS110	110	1	0.19 lb	<-->		
TJN125	125	1		<-->	TJS125	125	1		<-->		
TJN150	150	1		<-->	TJS150	150	1		<-->		
TJN175	175	1		<-->	TJS175	175	1		<-->		
TJN200	200	1	0.25 lb	<-->	TJS200	200	1	0.46 lb	<-->		
TJN225	225	1		<-->	TJS225	225	1		<-->		
TJN250	250	1		<-->	TJS250	250	1		<-->		
TJN300	300	1		<-->	TJS300	300	1		<-->		
TJN350	350	1	0.44 lb	<-->	TJS350	350	1	0.85 lb	<-->		
TJN400	400	1		<-->	TJS400	400	1		<-->		
TJN450	450	1		<-->	TJS450	450	1		<-->		
TJN500	500	1		<-->	TJS500	500	1		<-->		
TJN600	600	1	<-->	TJS600	600	1	<-->				

Edison Fuses – Extremely Fast-Acting Class T



300V TJN Fuses



600V TJS Fuses

CROSS REFERENCE				
VOLTS	EDISON	BUSSMANN	MERSEN GOULD	LITTELFUSE
300	TJN	JJN	A3T	JLLN
600	TJS	JJS	A6T	JLLS

TJN & TJS Fuse Dimensions

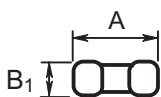

1A to 60A TJN
1A to 30A TJS

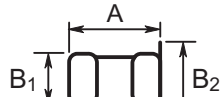

35A to 60A TJS

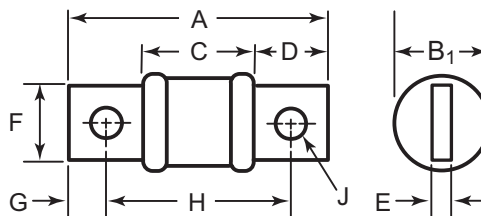

70A to 600A

Fuse Type	Current Rating	Overall Length	Maximum Diameter	Barrel Length	Blade Length	Blade Thickness	Blade Width	Mounting Hole Spacing										
	Range	A	B ₁	B ₂	C	D	E	F	G	H	J							
	(A)	(in [mm])																
TJN (300 VAC)	1-30	0.88 [22.4]	0.41 [10.4]	n/a	0.84 [21.3]	0.66 [16.8]	0.125 [3.18]	0.75 [19.1]	0.27 [6.86]	1.56 [39.6]	0.284 [7.21]							
	35-60		0.56 [14.2]									n/a (no blades)						
	70-100	2.16 [54.9]	0.82 [20.8]									0.80 [20.3]	0.19 [4.83]	0.88 [22.4]	0.34 [8.64]	1.69 [42.9]	0.344 [8.74]	
	110-200	2.44 [62.0]	1.06 [26.9]									0.86 [21.8]	0.95 [24.1]	0.25 [6.35]	1.00 [25.4]	0.42 [10.7]	1.84 [46.7]	0.406 [10.3]
	225-400	2.75 [69.9]	1.33 [33.8]									0.88 [22.4]	1.08 [27.4]	0.31 [7.87]	1.25 [31.8]	0.48 [12.2]	2.03 [51.6]	0.484 [12.3]
	450-600	3.06 [77.7]	1.60 [40.6]															
TJS (600 VAC)	1-30	1.50 [38.1]	0.56 [14.2]	n/a	1.64 [41.7]	0.66 [16.8]	0.125 [3.18]	0.75 [19.1]	0.27 [6.86]	2.36 [59.9]	0.281 [7.14]							
	35-60	1.56 [39.6]	0.81 [20.6]									1.00 [25.4]	n/a (no blades)					
	70-100	2.95 [74.9]	0.82 [20.8]									1.66 [42.2]	0.80 [20.3]	0.19 [4.83]	0.88 [22.4]	0.34 [8.64]	2.50 [63.5]	0.344 [8.74]
	110-200	3.25 [82.6]	1.07 [27.2]									1.73 [43.9]	0.95 [24.1]	0.25 [6.35]	1.00 [25.4]	0.42 [10.7]	2.72 [69.1]	0.406 [10.3]
	225-400	3.63 [92.2]	1.60 [40.6]									1.78 [45.2]	1.08 [27.4]	0.31 [7.87]	1.25 [31.8]	0.48 [12.2]	2.95 [74.9]	0.484 [12.3]
	450-600	3.98 [101]	2.08 [52.8]															

Edison Fuses – Extremely Fast-Acting Class T

TJN (300 VAC) Trip Curves

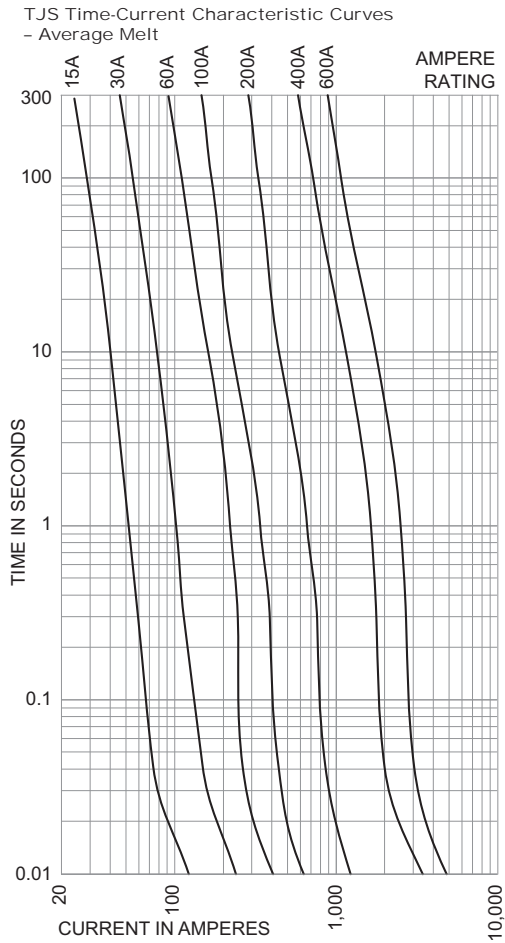
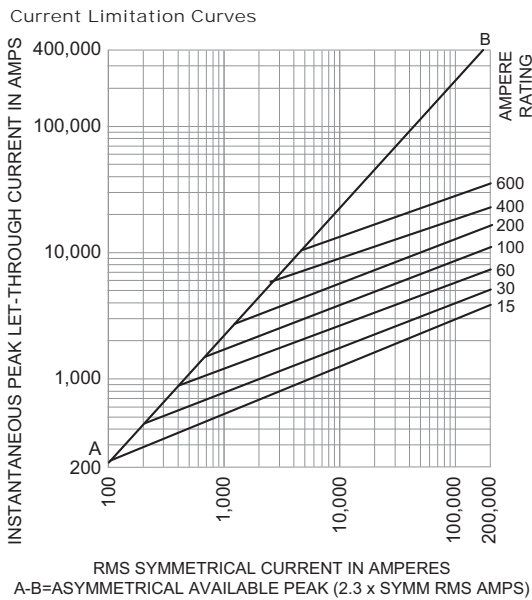

TJS (600 VAC) Trip Curves

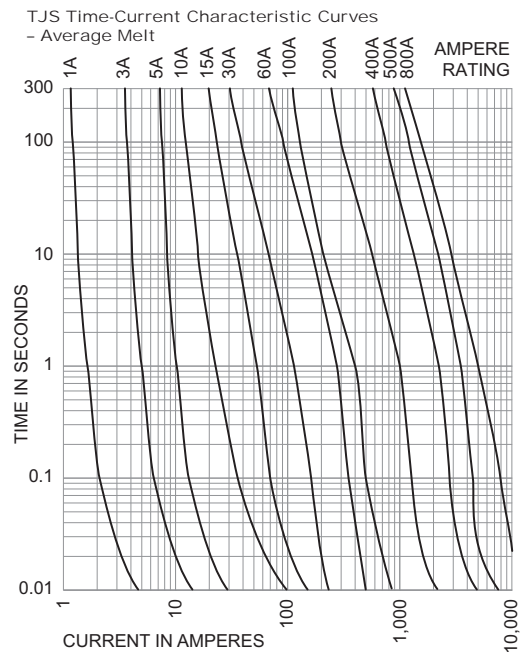
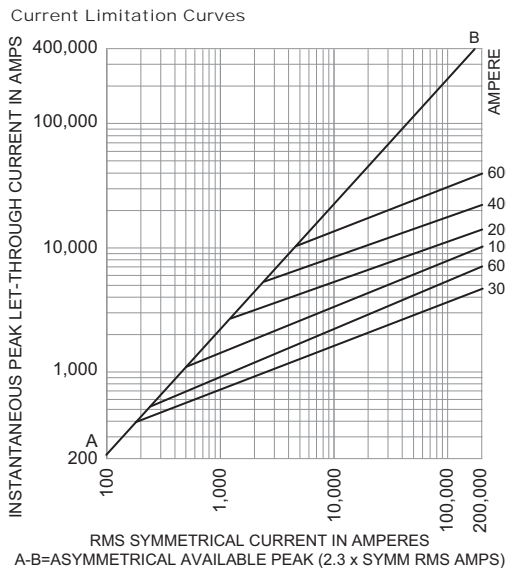

Edison Fuses – Selection Guide

Line Overview

The Edison family of fuses, fuse blocks and fuse holders is divided into two classes:

1. Current Limiting: Class CC, Class J, Class RK, Class T
2. General Purpose: Class M Midget and Small Dimension

The fuse selection guide below is a general summary of the specifications included for each fuse type. This selection guide does not include the many variables that can exist for specific situations such as local codes, unusual temperature, or other operating conditions. When selecting fuses, be sure to comply with any applicable PUBLIC SAFETY standards that apply to Overcurrent Protection Devices (OPD).

Edison Fuses Selection Guide and General Specifications											
Description	Current Limiting										
	Class J		Class RK5		Class RK1		Class T		Class CC		
Fuse Type	Fast-Acting	Time-Delay	Time-Delay				Extremely Fast-Acting	Fast-Acting	Time-Delay		
Part Number	JHL	JDL	ECNR	ECSR	LENRK	LESRK	TJN	TJS	HCLR	HCTR	EDCC
Voltage Rating	600 VAC 450 VDC	600 VAC 300 VDC*	250 VAC 125 VDC* (1–200A) 250 VDC* (201–600A)	600 VAC 300 VDC*	250 VAC 125 VDC* (10–60A) 250 VDC* (70–600A)	600 VAC 300 VDC*	300 VAC 160 VDC (15–600A)	600 VAC	600 VAC 300 VDC (15–20A)	600 VAC	600 VAC 300 VDC (0.5–2.25A) (20–30A)
Amp Rating	1 to 600		1 to 600	3 to 600	10 to 600	5 to 600	1 to 600		0.5 to 30	0.25 to 30	0.5 to 30
Interrupting Rating	200,000 RMS Symmetrical Amps										
Current Limiting	Class J		Class RK5		Class RK1		Class T		Class CC		
Agency Approvals	UL Listed Class J Guide JDDZ File E162363 CSA Certified HRCI-J per C22.2, No. 248.8 File 700489 RoHS compliant	UL Listed Class J Guide JDDZ File E162363 CSA Certified HRCI-J per C22.2, No. 248.8 File 700489	UL Listed, Class RK, Guide JDDZ, File E162363 CSA Certified HRCI-R per C22.2, No. 248.12, File 700489 (LENRK CSA File 053787)				UL Listed, Class T, Guide JDDZ, File E162363 CSA Certified HRCI-T per C22.2, No. 248.12, File 53787, Class 1422-02 & 1422-82		UL Listed to 248.4, Class CC, Guide JDDZ, File E162363, CSA certified HRCI-MISC per C22.2 No. 248.4, File 700489		
Dimensions	See product specification pages.								ferrule (in): 13/32, length (in): 1-1/2		
* Self-certified DC ratings											

Edison Fuses Selection Guide and General Specifications												
Description	General Purpose – Midget				General Purpose – Small Dimension Electronic							
	Fast-Acting		Time-Delay		Fast-Acting Ceramic	Fast-Acting Glass		Medium Time-Delay Glass	Time-Delay Ceramic	Time-Delay Glass	Fast-Acting Glass	Time-Delay Glass
Part Number	MCL	MOL	MEQ	MEN	ABC	AGC	GMA	GMC	MDA	MDL	S500	S506
Voltage Rating	600 VAC	250 VAC	500 VAC	250 VAC	250 VAC (0.5 to 20A) 125VAC: (25 to 30A) 125VDC	250VAC: (0.1 to 10A) 32VAC: (15 to 30A)	250VAC (0.063 - 3A) 125VAC (4 - 15A)	250VAC (0.5 - 3A) 125VAC (4 - 10A)	250VAC 125VDC (20A)	250VAC: (0.0625 to 8A) 32VAC: (10 to 20A)	250VAC	250VAC
Amp Rating	0.5 to 50	0.5 to 30	0.25 to 30	0.5 to 30	0.5 to 30	0.10 to 30	0.063 to 15	0.5 to 10	0.5 to 20	0.0625 to 20	0.032 to 10	0.25 to 6.3
Interrupting Rating	100,000 RMS Amps	10,000 RMS Amps			See specifications table on product pages							
Current Limiting	N/A				N/A							
Agency Approvals	UL Listed to 248.14, File E162443 CSA Cert. C22.2 Part 59.2, LR 700489				UL Listed standard 248-14 UL Listed Guide and File nos. (ABC 0.25-20 A): (AGC 1/100-10 A) JDYX and E19180 UL Recognition Guide and File nos. (ABC 20-30A): (AGC 11-30) JDYX2 and E19180 CSA Certification Record No: 053787 C 000 and Class No: 1422 01 and 1422 30	Designed to UL/CSA 248-14 UL Listed, Guide JDYX, File E19180 63mA-6A UL Recognition, Guide JDYX2, File E19180, 7A-15A CSA Certified, File 053787_C_000, 63mA-6A Class 1422-01		UL Listed standard 248-14 UL Listed Card: MDA 2/10-20A , MDL 1/16-8A (Guide JDYX, File E19180 UL Recognized Card: MDA 25-30A MDL 9-30A (Guide JDYX2, File E19180) CSA Certification Card: MDA 2/10-15A (Class No. 1422-01)		UL Recognized Guide JDYX2, File E19180 Semko Approval VDE Approval BSI Approval IMQ Approval RoHS compliant		
Dimensions	ferrule (in): 13/32 length (in): 1-1/2				1/4" x 1-1/4", (6.3mm x 32mm)		0.197" x 0.788" (5mm x 20mm)		1/4" x 1-1/4", (6.3mm x 32mm)		0.197" x 0.788" (5mm x 20mm)	

Edison Fuses – T300 & T600 Fuse Blocks for Class T Fuses

Description

For use with Class T fuses

T300 series: for use with 300V Class T fuses (TJN)

T600 series: for use with 600V Class T fuses (TJS)

Terminal type

- SR = Screw type; clip with re-inforcing spring
- CR = Box lug type; clip with reinforcing spring
- C = Box lug type; clip with reinforcing spring standard on FB rated 100A; spring not required above 100A for bolt-on fuses

Specifications

Construction: Glass Polyester; Phenolic on 600V

UL Flammability: 94V-0

Ratings:

T300: 300 VAC; 30–600A

T600: 600 VAC; 30–600A

Short-circuit Current Rating:

200,000 RMS Symmetrical Amps

Agency Approvals

- UL Listed, Guide IZLT, File E14853
- CSA, Class 6225-01, File 47235
- CE
- REACH
- RoHS

Edison Class T Fuse Blocks



Class T Fuse Blocks									
Part Number	Volts	Amps	Poles	Terminal Type	Wire Range (AWG)	Fig #	Wt. (lb)	Pcs /Pkg	Price
T30030-2SR	300	0.5 to 30	2	screw	10–18 Cu (only)	1	0.3	1	<--->
T30030-3SR			3				0.4		<--->
T30060-2CR			31 to 60				2		2–14 Cu/Al
T30060-3CR		3		0.5	<--->				
T30100-1CR		box lug	61 to 100	1	1/0–8 Cu/Al	4	0.6		<--->
T30100-3CR				3			1.5		<--->
T30200-1C			101 to 200	1	250 kcmil – 6 Cu/Al	5a	1.0		<--->
T30200-3C				3		5b	1.9		<--->
T30400-1C			201 to 400	1	600 kcmil – 2/0 Cu/Al	6	1.3		<--->
T30600-1C			401 to 600	1	(2) 600 kcmil – 4/0 Cu/Al	7	2.4		<--->
T60030-1SR	600		0.5 to 30	1	screw	10–18 Cu (only)	2	0.2	<--->
T60030-2SR				2				0.3	<--->
T60030-3SR		3		0.5				<--->	
T60060-1CR		31 to 60	1	2–14 Cu/Al	3	0.3	<--->		
T60060-2CR			2			0.4	<--->		
T60060-3CR		3	0.6	<--->					
T60100-1C		61 to 100	1	2/0–14 Cu/Al	4	1.0	<--->		
T60100-3C			3			1.5	<--->		
T60200-1C		101 to 200	1	250 kcmil – 6 Cu/Al	5a	1.0	<--->		
T60400-1C		201 to 400	1	600 kcmil – 2/0 Cu/Al	6	1.3	<--->		
T60600-1C		401 to 600	1	(2) 600 kcmil – 4/0 Cu/Al	7	2.6	<--->		

Edison Fuses – T300 & T600 Fuse Blocks for Class T Fuses

Fuse Block Terminal Torque Specifications

Terminal Tightening Torque Specs – Class T Fuse Blocks							
Part Number	Amps	Volts	Poles	Terminal Type	Wire Range (AWG)	Wire Torque (lb-in)	Fuse Torque (lb-in)
Tx0030-xSR	30	300, 600	1,2,3	screw	10–18 Cu (only)	20	n/a
Tx0060-xCR	60	300, 600	1,2,3	box lug	2–3	50	n/a
					4–6	45	
					8	40	
					10–14	35	
T30100-xCR	100	300	1,3		1/0–8 Cu/Al	100	n/a
T60100-xC	100	300	1,3		2/0–3	50	70
					4–6	45	
					8	40	
					10–14	35	
Tx0200-1C	200	300, 600	1		250 kcmil – 6 Cu/Al	375	132
T30200-3C	200	300	3	250 kcmil – 6 Cu/Al	275	132	
Tx0400-1C	400	300, 600	1	600 kcmil – 2/0 Cu/Al	500	192	
Tx0600-1C	600	300, 600	1	(2) 600 kcmil – 4/0 Cu/Al	450	380	

Fuse Block Dimensions

Fig.1: 300V; 0.5–60A

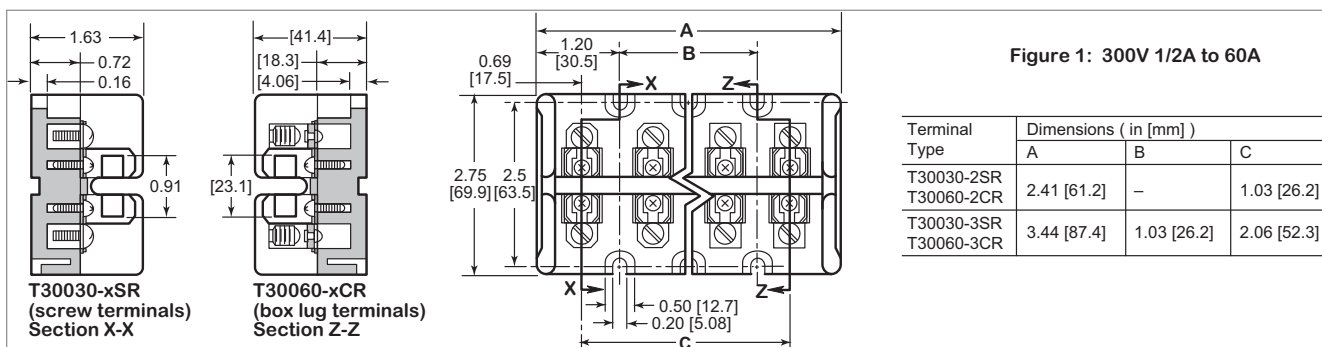

Fig.2: 600V; 0.5–30A

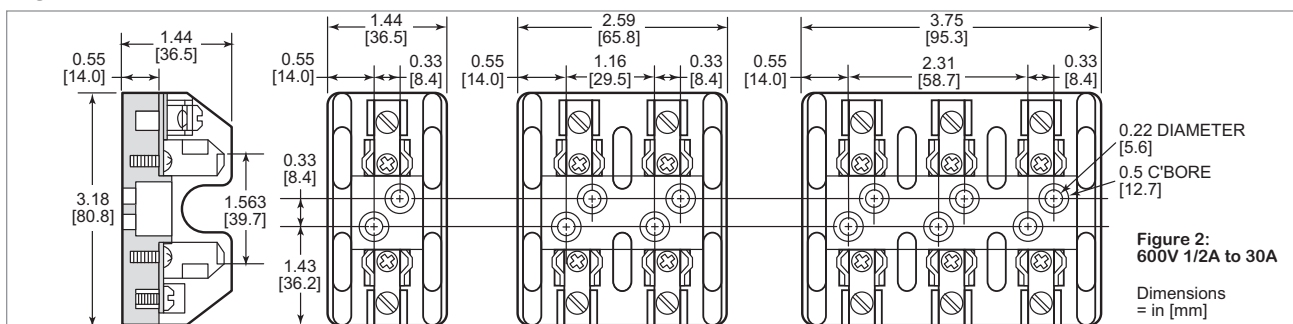
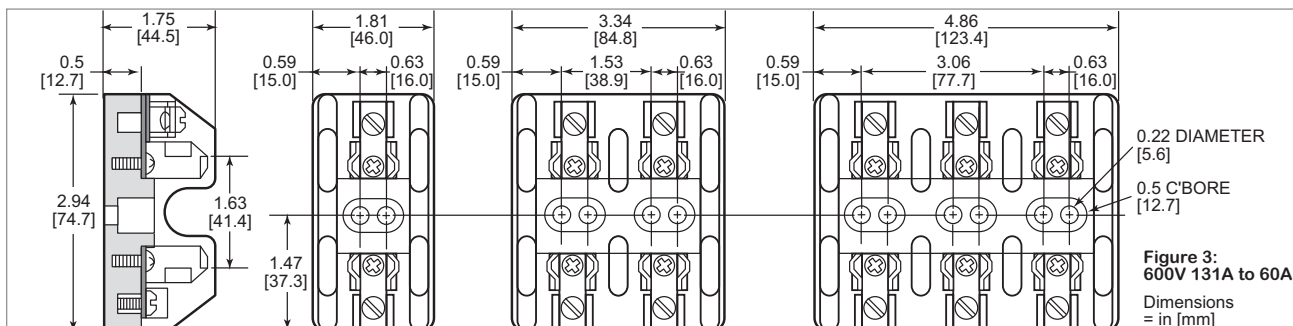

Fig.3: 600V; 31–60A



Edison Fuses – T300 & T600 Fuse Blocks for Class T Fuses

Fuse Block Dimensions

Fig.4: 300V, 600V; 61–100A

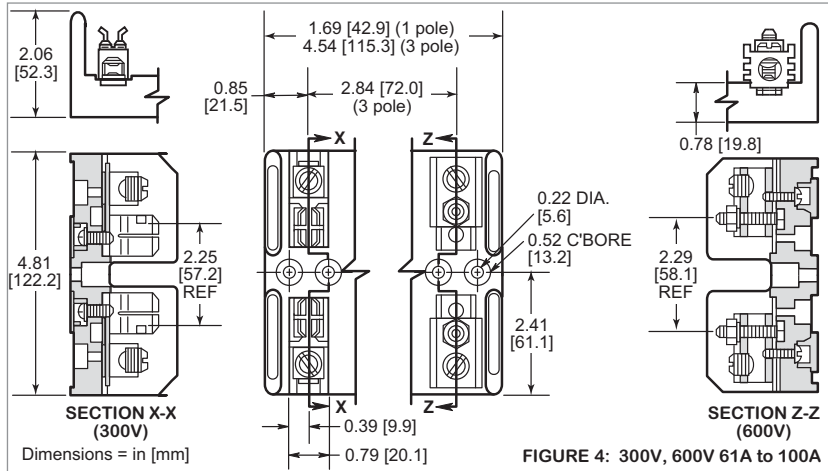

Fig.5a: 300V, 600V; 101–200A

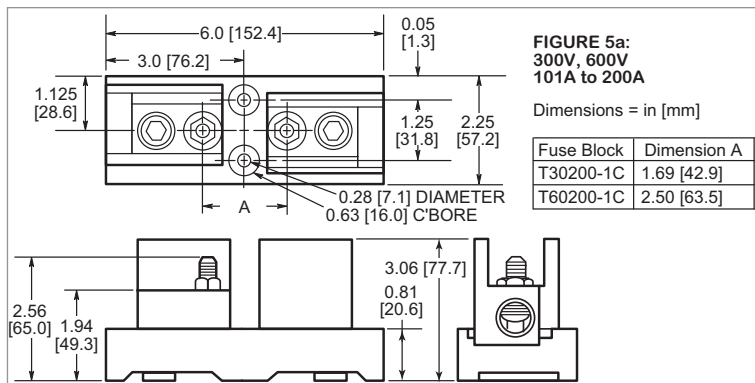
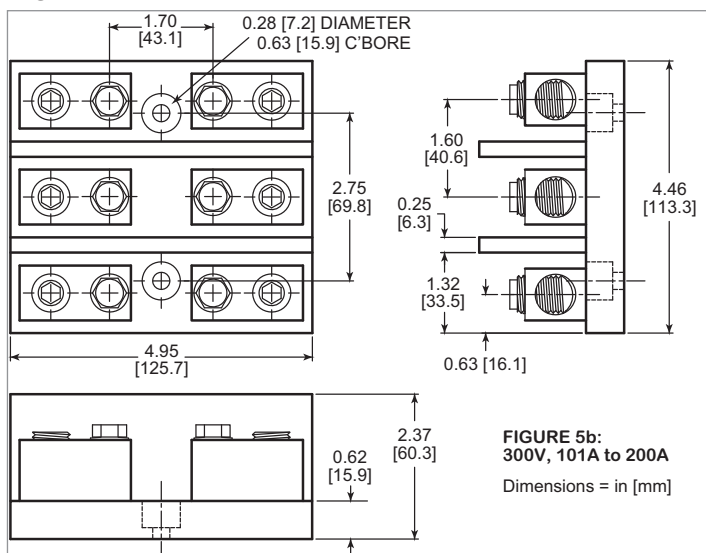
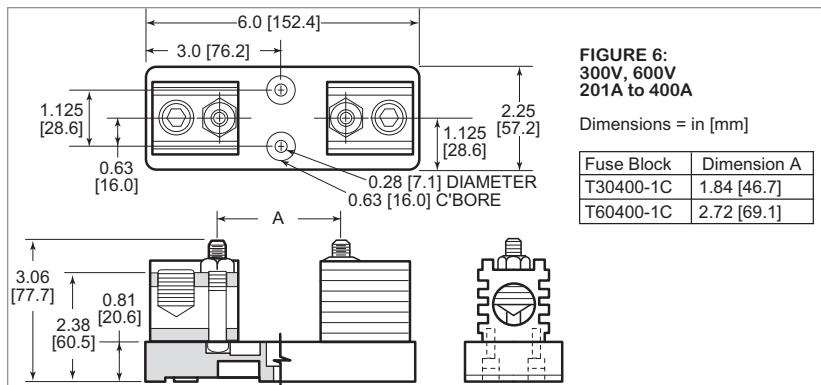
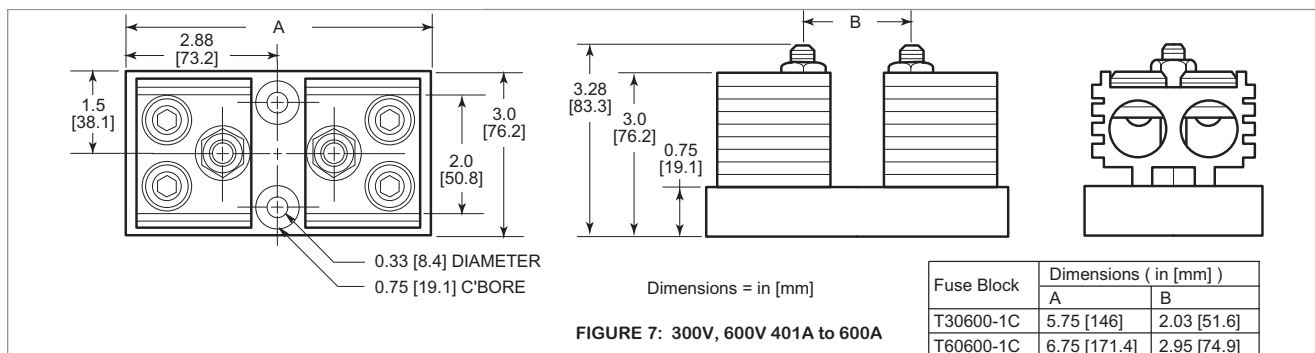

Fig.5b: 300V; 101–200A



Edison Fuses – T300 & T600 Fuse Blocks for Class T Fuses

Fuse Block Dimensions

Fig.6: 300V, 600V; 201–400A

Fig.7: 300V, 600V; 401–600A

Edison Fuses – Accessories



FP2



JV-L

Accessories			
Part Number	Description	Pcs/Pkg	Price
FP-2	Fuse puller for fuse dia. 13/32" - 13/16". Fuse type: 0-60A, 250V; 0-30A, 600V	1	<--->
JV-L* (Not Field Installable)	Multi-pole connection kit to connect new design multiple Class CC and Midget Class fuse holders together. Kit consists of 6 connectors and 3 handle pins to connect up to 4 fuse holders.		<--->

Note: Will not work with retired design fuse holders shipped before November 1, 2009.

**Roll pin punch or installation tool is required to install handle pins (Tool not sold by Automationdirect.com).*

Handle Pin Dimensions
 Diameter = 0.0625 in [1.58 mm]
 Length = 0.632 in [16.07 mm]

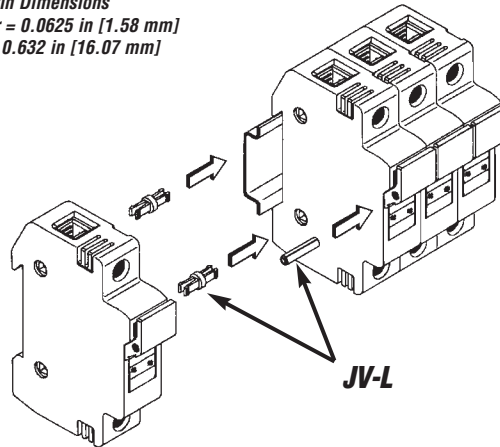

JV-L

Edison Cross Reference Guide

CROSS REFERENCE GUIDE By manufacturers type reference or series number. Ampere ratings must be added for ordering purposes.								
FUSE TYPE		VOLT	EDISON	BRUSH/ DORMAN	BUSSMANN	MERSEN / GOULD	GEC/CEFCO	LITTELFUSE
UL CLASS CURRENT LIMITING FUSES (CSA CLASS)								
CC (HRCI-CC)	Time-Delay	600	EDCC	–	LP-CC	ATDR	–	CCMR
	Time-Delay	600	HCTR	–	FNQ-R	ATQR	–	KLDR
	Fast-Acting	600	HCLR	HCLR	KTK-R	ATMR	CTK-R	KLKR
RK1	Time-Delay Dual Element	250	LENRK	–	LPN-RK-SP	A2DR	–	LLNRK
		600	LESRK	–	LPS-RK-SP	A6DR	–	LLSRK
RK5	Time-Delay Dual Element	250	ECNR	–	FRN-R	TR	–	FLNR
		600	ECSR	–	FRS-R	TRS	–	FLSR
J	Time-Delay Dual Element	600	JDL	–	LPJ	AJT	–	JTD
	High-Speed AC Drive	600	JHL	–	DFJ	HSJ	–	–
T	Extremely Fast-Acting	300	TJN	–	JJN	A3T	–	JLLN
		600	TJS	–	JJS	A6T	–	JLLS
UL CLASS GENERAL PURPOSE FUSES								
Midget	Fast-Acting	600	MCL	MCL	KTK	ATM	CTK	KLK
		250	MOL	MOL	BAF/BAN	OTM	–	BLF
	Time-Delay	500	MEQ	MEQ	FNQ	ATQ	–	FLQ
		250	MEN	MEN	FNM	TRM	–	FLM
1/4"x1/4" Ceramic	Fast-Acting	250/125	ABC	ABC	ABC	GAB	–	314
		1/4"x1/4"Glass	250/32	AGC	AGC	AGC	GGC	–
1/4"x1/4" Ceramic	Time-Delay	250	MDA	MDA	MDA	–	–	326
		1/4"x1/4"Glass	250/32	MDL	MDL	MDL	GDL	–
5x20 mm Glass	Fast-Acting	250/125	GMA	GMA	GMA	GGM	–	235
	Medium Time-Delay	250/125	GMC	GMC	GMC	GSC	–	–
5x20 mm Glass	Fast-Acting	250	S500	BDB	GDB	GSB	–	217
	Time-Delay	250	S506	BDC	GDC	GDG	–	218
Fuse Puller								
Fuse Puller FP-2		–	old - 38072 new - FP-2	–	FP-2	–	–	–