

DL05/06 I/O Option Modules

F0-08DAH-1 <--->

8-channel analog current output module, high resolution

Output Specifications	
Number of Channels	8
Output Range	4-20mA
Resolution	16-bit, .244µA/bit
Output Type	Current sourcing at 20mA max.
PLC Data Format	16-bit, Unsigned Int., 0-FFFF (binary) or 0-65535 (BCD) (Both require 2 words of V-memory)
Output value in program mode	4mA
Load Impedance	250-750 Ohms
Maximum Inductive Load	1 mH
Allowed load type	Grounded
Maximum Inaccuracy	0.2% of range
Maximum Full Scale Calibration Error (not including offset error)	±.025% of range maximum
Maximum Offset Calibration Error	±.025% of range maximum
Accuracy vs. Temperature	±50 ppm/ °C maximum full scale calibration change
Maximum Crosstalk	±10 counts
Linearity Error (End to End)	±16 count maximum (±0.025% of full scale) Monotonic with no missing codes
Output Stability and Repeatability	±10 counts after 10 min. warm-up typical
Output Ripple	.05% of Full Scale
Output Settling Time	5 ms max., 5 µs min. (full scale change)
All Channel Update Rate	100µs
Maximum Continuous Overload	Outputs open circuit protected
Type of Output Protection	Electronically current limited to 20mA or less
Output signal at power-up and power-down	4mA
Terminal Type (Included)	Removable: D0-ACC-4
External 24VDC Power Required	220mA
Base Power Required (5.0V)	25mA

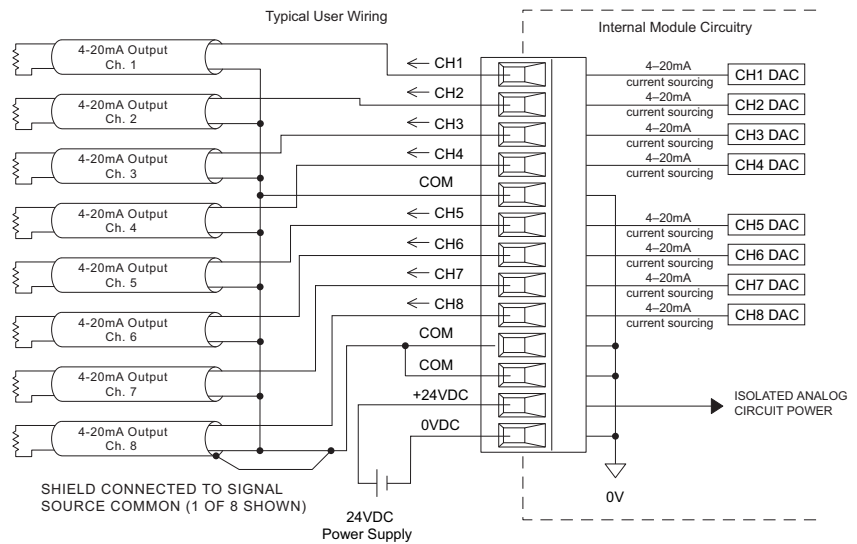
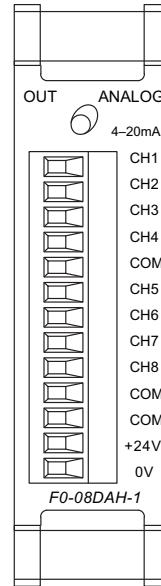

CPU	Firmware Required	DirectSOFT Required
DL05	Version 5.20 or later	DirectSOFT32 Version 3.0c or later
DL06	Version 2.30 or later	DirectSOFT32 Version 4.0, Build 16 or later



See page 2-68 for part numbers of ZIPLink cables and connection modules compatible with this I/O module.

Cut PLC wiring time to minutes instead of hours

The ZIPLink wiring system eliminates the normally tedious process of wiring PLC I/O to terminal blocks. Simply plug one end of a ZIPLink pre-wired terminal block cable into your I/O module and the other end into a ZIPLink connector module. It's that easy. ZIPLinks use half the space, at a fraction of the total cost of terminal blocks.

ZIPLinks are available in a variety of styles to suit your needs, including fused, relay and sensor/LED connector modules. ZIPLinks are available for all DL05/06 Series PLC discrete and analog input and output modules.

For complete information see ZIPLinks in the Terminal Blocks and Wiring Solutions section.



Specify your ZIPLink system

Use the Compatibility Matrix table below:

Step 1	Locate the I/O Module part number.
Step 2	Locate Connector Module Type. (Feedthrough Module, Fuse Module, etc...)
Step 3	Select the cable length by replacing the # symbol with: Blank = 0.5m, -1 = 1m, -2 = 2m ¹
¹ Note: Cable part number denotes compatibility between Connector Module and I/O Modules.	

ZIPLink Wiring System Compatibility Matrix for DL05/06 PLCs						
Step 2: Connector Module Type		Feedthrough Modules	Fuse Modules	Relay Modules	Sensor Input Modules	Pigtail Cable
Step 1: I/O Module	Number of Terminals	Step 3: Cables				
Inputs						
DO-10ND3	13	ZL-D0-CBL13#				
DO-10ND3F	13	ZL-D0-CBL13#				
DO-16ND3	24	ZL-D0-CBL24#L			ZL-D0-CBL24#L	ZL-D0-CBL24#P
FO-08NA-1	10	ZL-D0-CBL10#				
Outputs						
DO-10TD1	13	ZL-D0-CBL13#				
DO-16TD1	24	ZL-D0-CBL24#	ZL-D0-CBL24#	ZL-D0-CBL24#		ZL-D0-CBL24#P
DO-10TD2	13	ZL-D0-CBL13#				
DO-16TD2	24	ZL-D0-CBL24#	ZL-D0-CBL24#			ZL-D0-CBL24#P
DO-08TR	10	ZL-D0-CBL10#				
FO-04TRS*	13	ZL-D0-CBL13#				
Combo In/Out						
DO-07CDR	10	ZL-D0-CBL10#				
DO-08CDD1	13	ZL-D0-CBL13#				
Analog						
FO-04AD-1	8	ZL-D0-CBL8#				
FO-04AD-2	8	ZL-D0-CBL8#				
FO-08ADH-1	13	ZL-D0-CBL13#				
FO-08ADH-2	13	ZL-D0-CBL13#				
FO-04DAH-1	13	ZL-D0-CBL13#				
FO-08DAH-1	13	ZL-D0-CBL13#				
FO-04DAH-2	13	ZL-D0-CBL13#				
FO-08DAH-2	13	ZL-D0-CBL13#				
FO-2AD2DA-2	8	ZL-D0-CBL8#				
FO-4AD2DA-1	8	ZL-D0-CBL8#				
FO-4AD2DA-2	8	ZL-D0-CBL8#				
FO-04RTD**						
FO-04THM**						

* Caution: The FO-04TRS relay outputs are derated not to exceed 2 Amps per point when used with the ZIPLink wiring system.

** The F2-04RTD and F2-04THM modules are not supported by the ZIPLink wiring system. These modules require wire specific to the signal type.

ZIPLink Connector Modules specifications begin on page 26-56

ZIPLink Cables specifications begin on page 26-74