

DL05/06 Option Modules

F0-4AD2DA-1 <--->

4-channel analog current input and 2-channel analog current output module

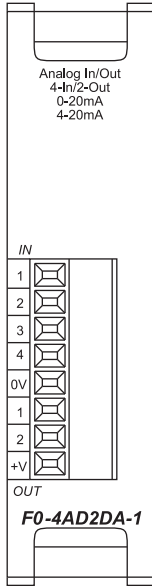

See page 2-68 for part numbers of ZIP Link cables and connection modules compatible with this I/O module.

F0-4AD2DA-1 Input Specifications	
Number of Channels	4, single ended (one common)
Input Range	0 to 20 mA or 4 to 20 mA (jumper selectable)
Resolution	12 bit (1 in 4096)
Step Response	25.0 mS (typ.) to 95% of full step change
Crosstalk	1/2 count max (-80db)*
Active Low-pass Filtering	-3 dB at 40 Hz (-12dB per octave)
Input Impedance	125 Ω ±0.1%, 1/8 watt
Absolute Max Ratings	-30mA to +30 mA, current input
Converter Type	Successive approximation
Linearity Error (end to end)	±2 counts
Input Stability	±1 count*
Full-scale Calibr. Error	±10 counts max. @ 20 mA*
Offset Calibration Error	±5 counts max. @ 0 mA*
Max Inaccuracy	±0.4% at 25°C (77°F) ±0.85% at 0 to 60°C (32 to 140°F)
Accuracy vs. Temp.	±100 ppm/°C typ.
Recommended Fuse	0.032 A, series 217 fast-acting, current inputs

F0-4AD2DA-1 Output Specifications	
Number of Channels	2, single ended (one common)
Output Range	0 to 20 mA or 4 to 20 mA (jumper selectable)
Output Type	Current sourcing
Resolution	12 bit (1 in 4096)
Max. Loop Voltage	30 VDC
Load/loop Power Supply	0-300 Ω /18-30 VDC
Linearity Error (end to end)	±2 counts (0.050% of full scale) max.*
Conversion Settling Time	400 μs max. for full scale change
Full-scale Calibration Error	±26 counts max. @ 300 Ω load ±18 counts max. @ 250 Ω load ±12 counts max. @ 125 Ω load
Offset Calibration Error	±10 counts max. @ 300 Ω load ±8 counts max. @ 250 Ω load ±6 counts max. @ 125 Ω load
Terminal Type (Included)	Removable: FO-IOCON
Max.Full- scale Inaccuracy (all errors included)	300 Ω load 0.4%. @ 60° C 250 Ω load 0.3%. @ 60° C 125 Ω load 0.2%. @ 60° C

* One count in the specification table is equal to one least significant bit of the analog data value (1 in 4096)

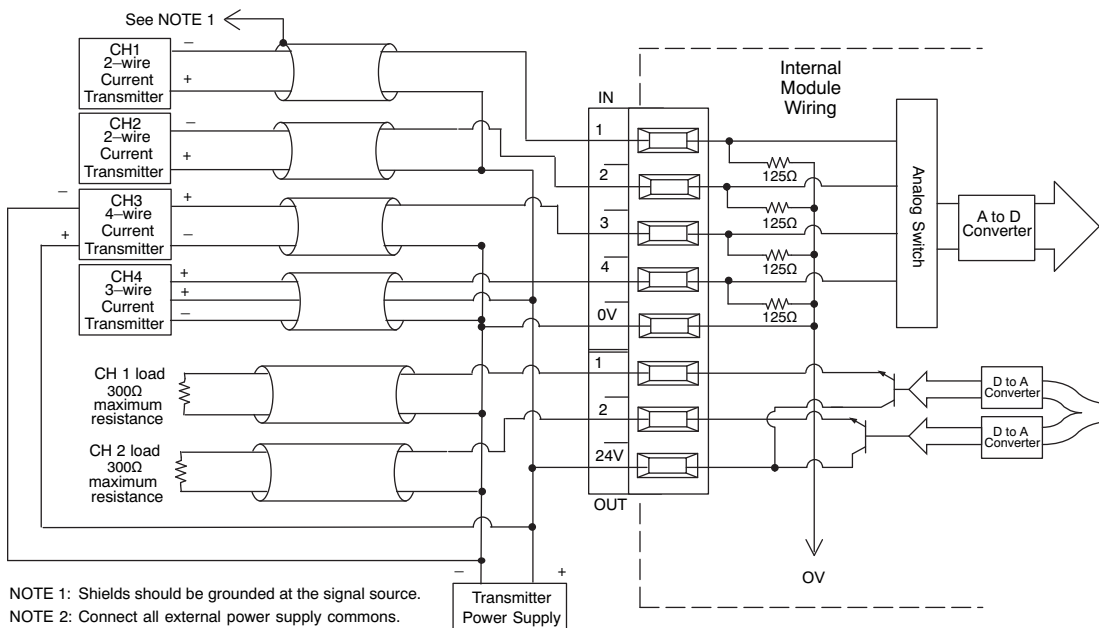

NOTE 1: Shields should be grounded at the signal source.
NOTE 2: Connect all external power supply commons.

Cut PLC wiring time to minutes instead of hours

The ZIPLink wiring system eliminates the normally tedious process of wiring PLC I/O to terminal blocks. Simply plug one end of a ZIPLink pre-wired terminal block cable into your I/O module and the other end into a ZIPLink connector module. It's that easy. ZIPLinks use half the space, at a fraction of the total cost of terminal blocks.

ZIPLinks are available in a variety of styles to suit your needs, including fused, relay and sensor/LED connector modules. ZIPLinks are available for all DL05/06 Series PLC discrete and analog input and output modules.

For complete information see ZIPLinks in the Terminal Blocks and Wiring Solutions section.



Specify your ZIPLink system

Use the Compatibility Matrix table below:

Step 1	Locate the I/O Module part number.
Step 2	Locate Connector Module Type. (Feedthrough Module, Fuse Module, etc...)
Step 3	Select the cable length by replacing the # symbol with: Blank = 0.5m, -1 = 1m, -2 = 2m ¹
¹ Note: Cable part number denotes compatibility between Connector Module and I/O Modules.	

ZIPLink Wiring System Compatibility Matrix for DL05/06 PLCs						
Step 2: Connector Module Type		Feedthrough Modules	Fuse Modules	Relay Modules	Sensor Input Modules	Pigtail Cable
Step 1: I/O Module	Number of Terminals	Step 3: Cables				
Inputs						
DO-10ND3	13	ZL-D0-CBL13#				
DO-10ND3F	13	ZL-D0-CBL13#				
DO-16ND3	24	ZL-D0-CBL24#L			ZL-D0-CBL24#L	ZL-D0-CBL24#P
FO-08NA-1	10	ZL-D0-CBL10#				
Outputs						
DO-10TD1	13	ZL-D0-CBL13#				
DO-16TD1	24	ZL-D0-CBL24#	ZL-D0-CBL24#	ZL-D0-CBL24#		ZL-D0-CBL24#P
DO-10TD2	13	ZL-D0-CBL13#				
DO-16TD2	24	ZL-D0-CBL24#	ZL-D0-CBL24#			ZL-D0-CBL24#P
DO-08TR	10	ZL-D0-CBL10#				
FO-04TRS*	13	ZL-D0-CBL13#				
Combo In/Out						
DO-07CDR	10	ZL-D0-CBL10#				
DO-08CDD1	13	ZL-D0-CBL13#				
Analog						
FO-04AD-1	8	ZL-D0-CBL8#				
FO-04AD-2	8	ZL-D0-CBL8#				
FO-08ADH-1	13	ZL-D0-CBL13#				
FO-08ADH-2	13	ZL-D0-CBL13#				
FO-04DAH-1	13	ZL-D0-CBL13#				
FO-08DAH-1	13	ZL-D0-CBL13#				
FO-04DAH-2	13	ZL-D0-CBL13#				
FO-08DAH-2	13	ZL-D0-CBL13#				
FO-2AD2DA-2	8	ZL-D0-CBL8#				
FO-4AD2DA-1	8	ZL-D0-CBL8#				
FO-4AD2DA-2	8	ZL-D0-CBL8#				
FO-04RTD**						
FO-04THM**						

* Caution: The FO-04TRS relay outputs are derated not to exceed 2 Amps per point when used with the ZIPLink wiring system.

** The F2-04RTD and F2-04THM modules are not supported by the ZIPLink wiring system. These modules require wire specific to the signal type.

ZIPLink Connector Modules specifications begin on page 26-56

ZIPLink Cables specifications begin on page 26-74