

# Analog Voltage Output Modules

| F2-02DAS-2 2-Channel 0-5V, 0-10V Isolated Analog Output <----> |   |
|--|---|
| <b>Number of Channels</b>                                      | 2, isolated   |
| <b>Output Ranges</b>   | 0-5V, 0-10V   |
| <b>Resolution</b>  | 16 bit (1 in 65536)   |
| <b>Output Type</b>   | Sourced through external loop supply  |
| <b>Digital Output Points Required</b>                          | 32 (Y) output points<br>(16 binary data bits, 2 channel ID bits)  |
| <b>Isolation Voltage</b>                                       | ±750 V continuous, channel to channel,<br>channel to logic  |
| <b>Base Power Required 5VDC</b>                                | 60 mA   |
| <b>External Power Supply</b>                                   | 21.6-26.4 VDC @ 60 mA per channel   |
| <b>Load Impedance</b>  | 2 kΩ min  |
| <b>PLC Update Rate</b>   | 1 channel per scan maximum (D2-230 CPU)<br>2 channels per scan maximum (D2-240, D2-250(-1) and D2-260 CPUs) |
| <b>Conversion Settling Time</b>                                | 3ms to 0.1% of full scale   |

|                                     |   |
|-------------------------------------|---|
| <b>Linearity Error (end to end)</b> | ±10 count (±0.015% of full scale) maximum             |
| <b>Gain Calibration Error</b>       | ±32 counts (±0.05%)                                   |
| <b>Offset Calibration Error</b>     | ±13 counts (±0.02%)                                   |
| <b>Output Drift</b>                 | 50 ppm/°C   |
| <b>Maximum Inaccuracy</b>           | 0.07% @ 25°C (77°F)<br>0.18% 0 to 60°C (32° to 140°F) |
| <b>Operating Temperature</b>        | 0° to 60°C (32° to 140°F)                             |
| <b>Storage Temperature</b>          | -20° to 70°C (-4° to 158°F)                           |
| <b>Relative Humidity</b>            | 5 to 95% (non-condensing)                             |
| <b>Environmental air</b>            | No corrosive gases permitted                          |
| <b>Vibration</b>                    | MIL STD 810C 514.2                                    |
| <b>Shock</b>                        | MIL STD 810C 516.2                                    |
| <b>Noise Immunity</b>               | NEMA ICS3-304   |
| <b>Terminal Type (included)</b>     | Removable; D2-810CON                                  |

See Wiring Solutions for part numbers of ZIPLink cables and connection modules compatible with this I/O module.



**NOTE 1:** Shields should be connected to the 0V of the module or the 0V of the P/S.

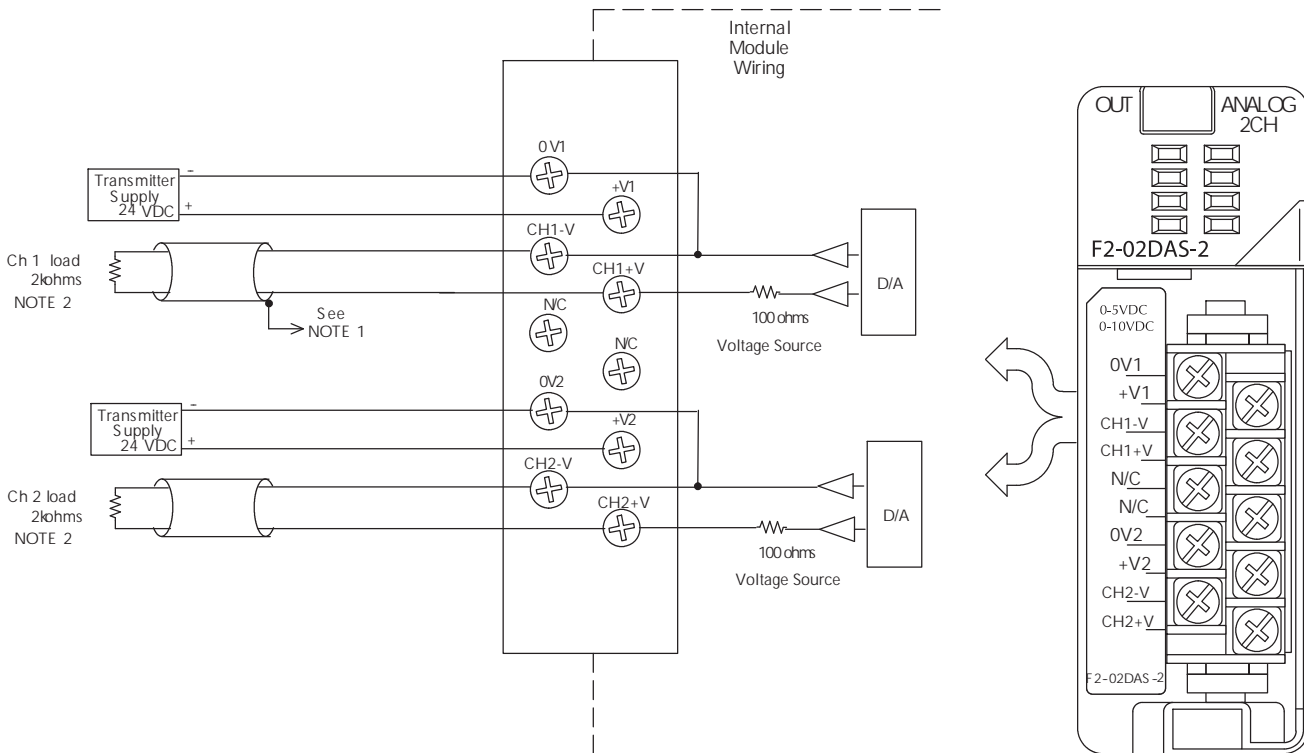

## Wiring Solutions using the ZIPLink Wiring System

ZIPLinks eliminate the normally tedious process of wiring between devices by utilizing prewired cables and DIN rail mount connector modules. It's as simple as plugging in a cable connector at either end or terminating wires at only one end. Prewired cables keep installation clean and efficient, using half the space at a fraction of the cost of standard terminal blocks. There are several wiring solutions available when using the ZIPLink System ranging from PLC I/O-to-ZIPLink Connector

Modules that are ready for field termination, options for connecting to third party devices, GS, DuraPulse and SureServo Drives, and specialty relay, transorb and communications modules. Pre-printed I/O-specific adhesive label strips for quick marking of ZIPLink modules are provided with ZIPLink cables. See the following solutions to help determine the best ZIPLink system for your application.

### Solution 1: DirectLOGIC, CLICK and Productivity3000 I/O Modules to ZIPLink Connector Modules

When looking for quick and easy I/O-to-field termination, a ZIPLink connector module used in conjunction with a prewired ZIPLink cable, consisting of an I/O terminal block at one end and a multi-pin connector at the other end, is the best solution.



Using the PLC I/O Modules to ZIPLink Connector Modules selector tables located in this section,

1. Locate your I/O module/PLC.
2. Select a ZIPLink Module.
3. Select a corresponding ZIPLink Cable.

### Solution 2: DirectLOGIC, CLICK and Productivity3000 I/O Modules to 3rd Party Devices

When wanting to connect I/O to another device within close proximity of the I/O modules, no extra terminal blocks are necessary when using the ZIPLink Pigtail Cables. ZIPLink Pigtail Cables are prewired to an I/O terminal block with color-coded pigtail with soldered-tip wires on the other end.



Using the I/O Modules to 3rd Party Devices selector tables located in this section,

1. Locate your PLC I/O module.
2. Select a ZIPLink Pigtail Cable that is compatible with your 3rd party device.

### Solution 3: GS Series and DuraPulse Drives Communication Cables

Need to communicate via Modbus RTU to a drive or a network of drives?

ZIPLink cables are available in a wide range of configurations for connecting to PLCs and SureServo, SureStep, Stellar Soft Starter and AC drives. Add a ZIPLink communications module to quickly and easily set up a multi-device network.

Using the Drives Communication selector tables located in this section,

1. Locate your Drive and type of communications.
2. Select a ZIPLink cable and other associated hardware.



## Solution 4: Serial Communications Cables

ZIPLink offers communications cables for use with *Direct*LOGIC, CLICK, and Productivity3000 CPUs, that can also be used with other communications devices. Connections include a 6-pin RJ12 or 9-pin, 15-pin and 25-pin D-sub connectors which can be used in conjunction with the RJ12 or D-Sub Feedthrough modules.

Using the **Serial Communications Cables** selector table located in this section,

1. Locate your connector type
2. Select a cable.



## Solution 5: Specialty ZIPLink Modules

For additional application solutions, ZIPLink modules are available in a variety of configurations including stand-alone relays, 24VDC and 120VAC transorb modules, D-sub and RJ12 feedthrough modules, communication port adapter and distribution modules, and *SureServo* 50-pin I/O interface connection.

Using the **ZIPLink Specialty Modules** selector table located in this section,

1. Locate the type of application.
2. Select a ZIPLink module.



## Solution 6: ZIPLink Connector Modules to 3rd Party Devices

If you need a way to connect your device to terminal blocks without all that wiring time, then your pigtail cables with color-coded soldered-tip wires are a good solution. Used in conjunction with any compatible ZIPLink Connector Modules, a pigtail cable keeps wiring clean and easy and reduces troubleshooting time.

Using the **Universal Connector Modules and Pigtail Cables** table located in this section,

1. Select module type.
2. Select the number of pins.
3. Select cable.



| DL205 PLC Input Module ZIPLink Selector |            |             |                 |                  |
|---|------------|-------------|-----------------|------------------|
| PLC                                     |            | ZIPLink     |                 |                  |
| Input Module                            | # of Terms | Component   | Module Part No. | Cable Part No. † |
| D2-08ND3                                | 10         | Feedthrough | ZL-RTB20        | ZL-D2-CBL10*     |
| D2-16ND3-2                              | 19         | Feedthrough | ZL-RTB20        | ZL-D2-CBL19*     |
|   |            | Sensor      | ZL-LTB16-24     | ZL-D2-CBL19*     |
| D2-32ND3 <sup>1</sup>                   | 40         | Feedthrough | ZL-RTB40        | ZL-D24-CBL40*    |
|   |            |             |                 | ZL-D24-CBL40*X   |
|   |            | Sensor      | ZL-LTB32-24     | ZL-D24-CBL40*    |
|   |            |             |                 | ZL-D24-CBL40*X   |
| D2-32ND3-2 <sup>1</sup>                 | 40         | Feedthrough | ZL-RTB40        | ZL-D24-CBL40*    |
|   |            |             |                 | ZL-D24-CBL40*X   |
|   |            | Sensor      | ZL-LTB32-24     | ZL-D24-CBL40*    |
|   |            |             |                 | ZL-D24-CBL40*X   |
| D2-08NA-1                               | 10         | Feedthrough | ZL-RTB20        | ZL-D2-CBL10*     |
| D2-08NA-2                               | 10         | Feedthrough | ZL-RTB20        | ZL-D2-CBL10*     |
| D2-16NA                                 | 19         | Feedthrough | ZL-RTB20        | ZL-D2-CBL19*     |

† X in the part number represents a 45° angle.

| DL205 PLC Combo In/Out Module ZIPLink Selector |            |             |                 |                |
|--|------------|-------------|-----------------|----------------|
| PLC  |            | ZIPLink     |                 |                |
| Combo Module                                   | # of Terms | Component   | Module Part No. | Cable Part No. |
| D2-08CDR                                       | 10         | Feedthrough | ZL-RTB20        | ZL-D2-CBL10*   |

| DL205 PLC Analog Module ZIPLink Selector |              |             |            |              |
|--|--------------|-------------|------------|--------------|
| PLC                                      |              | ZIPLink     |            |              |
| Analog Module                            | # of Terms   | Component   | Module     | Cable        |
| F2-04AD-1                                | 10           | Feedthrough | ZL-RTB20   | ZL-D2-CBL10* |
| F2-04AD-1L                               | 10           | Feedthrough | ZL-RTB20   | ZL-D2-CBL10* |
| F2-08AD-1                                | 10           | Feedthrough | ZL-RTB20   | ZL-D2-CBL10* |
| F2-04AD-2                                | 10           | Feedthrough | ZL-RTB20   | ZL-D2-CBL10* |
| F2-04AD-2L                               | 10           | Feedthrough | ZL-RTB20   | ZL-D2-CBL10* |
| F2-08AD-2                                | 10           | Feedthrough | ZL-RTB20   | ZL-D2-CBL10* |
| F2-02DA-1                                | 10           | Feedthrough | ZL-RTB20   | ZL-D2-CBL10* |
| F2-02DA-1L                               | 10           | Feedthrough | ZL-RTB20   | ZL-D2-CBL10* |
| F2-02DAS-1                               | 10           | Feedthrough | ZL-RTB20   | ZL-D2-CBL10* |
| F2-08DA-1                                | 19           | Feedthrough | ZL-RTB20   | ZL-D2-CBL19* |
| F2-02DA-2                                | 10           | Feedthrough | ZL-RTB20   | ZL-D2-CBL10* |
| F2-02DA-2L                               | 10           | Feedthrough | ZL-RTB20   | ZL-D2-CBL10* |
| F2-02DAS-2                               | 10           | Feedthrough | ZL-RTB20   | ZL-D2-CBL10* |
| F2-08DA-2                                | 10           | Feedthrough | ZL-RTB20   | ZL-D2-CBL10* |
| F2-4AD2DA                                | 10           | Feedthrough | ZL-RTB20   | ZL-D2-CBL10* |
| F2-8AD4DA-1                              | 19           | Feedthrough | ZL-RTB20   | ZL-D2-CBL19* |
| F2-8AD4DA-2                              | 19           | Feedthrough | ZL-RTB20   | ZL-D2-CBL19* |
| F2-04RTD <sup>4</sup>                    | Matched Only |             | See Note 4 |              |
| F2-04THM <sup>4</sup>                    | Matched Only |             | See Note 4 |              |



| DL205 PLC Output Module ZIPLink Selector |            |             |                       |                  |
|--|------------|-------------|-----------------------|------------------|
| PLC                                      |            | ZIPLink     |                       |                  |
| Output Module                            | # of Terms | Component   | Module Part No.       | Cable Part No. † |
| D2-04TD1 <sup>2</sup>                    | 10         | Feedthrough | ZL-RTB20              | ZL-D2-CBL10*     |
| D2-08TD1                                 | 10         | Feedthrough | ZL-RTB20              | ZL-D2-CBL10*     |
| D2-08TD2                                 | 10         | Feedthrough | ZL-RTB20              | ZL-D2-CBL10*     |
| D2-16TD1-2                               | 19         | Feedthrough | ZL-RTB20              | ZL-D2-CBL19*     |
|  |            | Fuse        | ZL-RFU20 <sup>5</sup> | ZL-D2-CBL19*     |
|  |            | Relay       | ZL-RRL16-24-1         | ZL-D2-CBL19*     |
| D2-16TD2-2                               | 19         | Feedthrough | ZL-RTB20              | ZL-D2-CBL19*     |
|  |            | Fuse        | ZL-RFU20 <sup>5</sup> | ZL-D2-CBL19*     |
| F2-16TD1P                                | 19         | Feedthrough | ZL-RTB20              | ZL-D2-CBL19*     |
|  |            | Relay       | ZL-RRL16-24-2         | ZL-D2-CBL19*     |
| F2-16TD2P                                | 19         | Feedthrough | ZL-RTB20              | ZL-D2-CBL19*     |
|  |            | Relay       | ZL-RRL16-24-2         | ZL-D2-CBL19*     |
| D2-32TD1 <sup>1</sup>                    | 40         | Feedthrough | ZL-RTB40              | ZL-D24-CBL40*    |
|  |            |             |                       | ZL-D24-CBL40*X   |
|  |            | Fuse        | ZL-RFU40 <sup>5</sup> | ZL-D24-CBL40*    |
| D2-32TD2 <sup>1</sup>                    | 40         | Feedthrough | ZL-RTB40              | ZL-D24-CBL40*    |
|  |            |             |                       | ZL-D24-CBL40*X   |
|  |            | Fuse        | ZL-RFU40 <sup>5</sup> | ZL-D24-CBL40*    |
| D2-08TA                                  | 10         | Feedthrough | ZL-RTB20              | ZL-D2-CBL10*     |
| F2-08TA                                  | 10         | Feedthrough | ZL-RTB20              | ZL-D2-CBL10*     |
| D2-12TA                                  | 19         | Feedthrough | ZL-RTB20              | ZL-D2-CBL19*     |
|  |            | Fuse        | ZL-RFU20 <sup>5</sup> | ZL-D2-CBL19*     |
| D2-04TRS <sup>2</sup>                    | 10         | Feedthrough | ZL-RTB20              | ZL-D2-CBL10*     |
| D2-08TR                                  | 10         | Feedthrough | ZL-RTB20              | ZL-D2-CBL10*     |
| F2-08TRS <sup>2</sup>                    | 19         | Feedthrough | ZL-RTB20              | ZL-D2-CBL19*     |
| F2-08TR <sup>3</sup>                     | 10         | Feedthrough | ZL-RTB20              | ZL-D2-CBL10*     |
| D2-12TR                                  | 19         | Feedthrough | ZL-RTB20              | ZL-D2-CBL19*     |
|  |            | Fuse        | ZL-RFU20 <sup>5</sup> | ZL-D2-CBL19*     |

† X in the part number represents a 45° angle plug

\* Select the cable length by replacing the \* with: Blank = 0.5m, -1 = 1.0m, or -2 = 2.0m.

<sup>1</sup> To make a custom cable for the 32-point modules, use: Ribbon-style Connector ZL-D24-CON-R, Solder-style 180° connector ZL-D24-CON or Solder-style 45° connector ZL-D24-CON-X

<sup>2</sup> Caution: The D2-04TD1, D2-04TRS, and F2-08TRS outputs are derated not to exceed module specs 2A per point and 2A per common when used with the ZIPLink wiring system.

<sup>3</sup> The F2-08TR outputs are derated not to exceed 2A per point and 4A per common when used with the ZIPLink wiring system.

<sup>4</sup> The F2-04RTD and F2-04THM modules are not supported by the ZIPLink wiring system.

<sup>5</sup> Note: Fuses (5 x 20 mm) are not included. See Edison Electronic Fuse section for (5 x 20 mm) fuse. S500 and GMA electronic circuit protection for fast-acting maximum protection. S506 and GMC electronic circuit protection for time-delay performance. Ideal for inductive circuits.

To ensure proper operation, do not exceed the voltage and current rating of ZIPLink module. ZL-RFU20 = 2A per circuit; ZL-RFU40 = 400 mA per circuit.



**NOTE: ZIPLINK CONNECTOR MODULES AND ZIPLINK CABLES SPECIFICATIONS ARE IN THE ZIPLINK CATALOG SECTION.**

# Power Requirements

## These charts help determine your power requirements

This section shows the amount of power supplied by each of the base power supplies and the amount of power consumed by each DL205 device. The Power Consumed charts list how much INTERNAL power from each power source is required for the DL205 devices. Use this information when calculating the power budget for your system.

In addition to the internal power sources, the DL205 bases offer a 24 VDC auxiliary power supply with external power connections. This auxiliary power supply can power external devices.

## Use ZIPLinks to reduce power requirements

If your application requires a lot of relay outputs, consider using the ZIPLink AC or DC relay output modules. These modules can switch high current (10A) loads without putting a load on your base power budget. Refer to the Terminal Blocks and Wiring Solutions section in this catalog for more information.

This logo is placed next to the I/O modules that are supported by the ZIPLink connection systems. See the I/O module specifications at the end of this section.



| Power Consumed            |        |               |
|---------------------------|--------|---------------|
| Device                    | 5V(mA) | 24V Auxiliary |
| <b>Operator Interface</b> |        |               |
| DV-1000                   | 150    | 0             |
| C-more Micro-Graphic      | 210    | 0             |

| Power Supplied |       |        |               |              |       |        |               |
|----------------|-------|--------|---------------|--------------|-------|--------|---------------|
| Device         | Price | 5V(mA) | 24V Auxiliary | Device       | Price | 5V(mA) | 24V Auxiliary |
| <b>Bases</b>   |       |        |               | <b>Bases</b> |       |        |               |
| D2-03B-1       | <---> | 2600   | 300           | D2-06BDC1-1  | <---> | 2600   | None          |
| D2-03BDC1-1    | <---> | 2600   | None          | D2-06BDC2-1  | <---> | 2600   | 300           |
| D2-04B-1       | <---> | 2600   | 300           | D2-09B-1     | <---> | 2600   | 300           |
| D2-04BDC1-1    | <---> | 2600   | None          | D2-09BDC1-1  | <---> | 2600   | None          |
| D2-06B-1       | <---> | 2600   | 300           | D2-09BDC2-1  | <---> | 2600   | 300           |

| Power Consumed                   |        |               |
|----------------------------------|--------|---------------|
| Device                           | 5V(mA) | 24V Auxiliary |
| <b>CPUs</b>                      |        |               |
| D2-230                           | 120    | 0             |
| D2-240                           | 120    | 0             |
| D2-250-1                         | 330    | 0             |
| D2-260                           | 330    | 0             |
| H2-WPLC*-**                      | 680    | 0             |
| <b>DC Input Modules</b>          |        |               |
| D2-08ND3                         | 50     | 0             |
| D2-16ND3-2                       | 100    | 0             |
| D2-32ND3                         | 25     | 0             |
| D2-32ND3-2                       | 25     | 0             |
| <b>AC Input Modules</b>          |        |               |
| D2-08NA-1                        | 50     | 0             |
| D2-08NA-2                        | 100    | 0             |
| D2-16NA                          | 100    | 0             |
| <b>Input Simulator Module</b>    |        |               |
| F2-08SIM                         | 50     | 0             |
| <b>DC Output Modules</b>         |        |               |
| D2-04TD1                         | 60     | 20            |
| D2-08TD1                         | 100    | 0             |
| D2-08TD2                         | 100    | 0             |
| D2-16TD1-2                       | 200    | 80            |
| D2-16TD2-2                       | 200    | 0             |
| F2-16TD1P                        | 70     | 50            |
| F2-16TD2P                        | 70     | 50            |
| D2-32TD1                         | 350    | 0             |
| D2-32TD2                         | 350    | 0             |
| <b>AC Output Modules</b>         |        |               |
| D2-08TA                          | 250    | 0             |
| F2-08TA                          | 250    | 0             |
| D2-12TA                          | 350    | 0             |
| <b>Relay Output Modules</b>      |        |               |
| D2-04TRS                         | 250    | 0             |
| D2-08TR                          | 250    | 0             |
| F2-08TR(S)                       | 670    | 0             |
| D2-12TR                          | 450    | 0             |
| <b>Combination In/Out Module</b> |        |               |
| D2-08CDR                         | 200    | 0             |

| Power Consumed             |            |                   |
|----------------------------|------------|-------------------|
| Device                     | 5V(mA)     | 24V Auxiliary     |
| <b>Analog Modules</b>      |            |                   |
| F2-04AD-1                  | 100        | 5                 |
| F2-04AD-2                  | 110        | 5                 |
| F2-08AD-1                  | 100        | 5                 |
| F2-08AD-2                  | 100        | 5                 |
| F2-02DA-1                  | 40         | 60 (note 1)       |
| F2-02DA-1L                 | 40         | 70 @ 12V (note 1) |
| F2-02DA-2                  | 40         | 60                |
| F2-02DA-2L                 | 40         | 70 @ 12V          |
| F2-02DAS-1                 | 100        | 50 / channel      |
| F2-02DAS-2                 | 100        | 60 / channel      |
| F2-08DA-1                  | 30         | 50 (note 1)       |
| F2-08DA-2                  | 60         | 140               |
| F2-4AD2DA                  | 60         | 80 (note 1)       |
| F2-8AD4DA-1                | 35         | 100 (note 1)      |
| F2-8AD4DA-2                | 35         | 80 (note 1)       |
| F2-04RTD                   | 90         | 0                 |
| F2-04THM                   | 110        | 60                |
| <b>Specialty Modules</b>   |            |                   |
| D2-CTRINT                  | 50*        | 0                 |
| D2-CM / D2-EM              | 100/130    | 0                 |
| H2-CTRIO                   | 400        | 0                 |
| D2-DCM                     | 300        | 0                 |
| F2-DEVNETS                 | 160        | 0                 |
| F2-SDS-1                   | 160        | 0                 |
| H2-PBC                     | 530        | 0                 |
| H2-EBC100                  | 300        | 0                 |
| H2-EBC-F                   | 640        | 0                 |
| H2-ECOM100                 | 300        | 0                 |
| H2-ECOM-F                  | 640        | 0                 |
| F2-CP128                   | 235        | 0                 |
| <b>Remote I/O</b>          |            |                   |
| H2-ERM(-F)                 | 320, (450) | 0                 |
| D2-RMSM                    | 200        | 0                 |
| D2-RSSS                    | 150        | 0                 |
| <b>Programming Devices</b> |            |                   |
| D2-HPP                     | 200        | 0                 |

\*requires external 5VDC for outputs  
Note 1: Add an additional 20 mA per output loop.