

# Temperature Input Modules

F2-04RTD 4-Channel RTD In <--->	
<b>Number of Channels</b>	4
<b>Input Ranges</b>	Type Pt100: -200.0/850.0°C, -328/1562°F Type Pt1000: -200.0/595.0°C, -328/1103°F Type jPt100: -38.0/450.0°C, -36/842°F Type CU-10/25z: -200.0/260.0°C, -328/500°F
<b>Resolution</b>	16 bit (1 in 65535)
<b>Display Resolution</b>	±0.1°C, ±0.1°F (±3276.7)
<b>RTD Excitation Current</b>	200 µA
<b>Input Type</b>	Differential
<b>Notch Filter</b>	>100 db notches at 50/60 Hz -3db=13.1Hz
<b>Maximum Setting Time</b>	100ms (full-scale step input)
<b>Common Mode Range</b>	0-5 VDC
<b>Absolute Maximum Ratings</b>	Fault protected inputs to ±50 VDC
<b>Sampling Rate</b>	160 ms per channel

<b>Converter Type</b>	Charge Balancing
<b>Linearity Error</b>	±.05°C maximum, ±.01°C typical
<b>Maximum Inaccuracy</b>	±1°C
<b>PLC Update Rate</b>	4 channel/scan max., 240/250(-1)/D2-260CPUs 1 channel per scan max., 230 CPU
<b>Digital Input Points Required</b>	32 input points (16 binary data bits, 2 channel ID bits, 4 fault bits)
<b>Base Power Required 5VDC</b>	90 mA
<b>Operating Temperature</b>	32° to 140°F (0° to 60°C)
<b>Storage Temperature</b>	-4° to 158°F (-20° to 70°C)
<b>Temperature Drift</b>	None (self-calibrating)
<b>Relative Humidity</b>	5 to 95% (non-condensing)
<b>Environmental Air</b>	No corrosive gases permitted
<b>Vibration</b>	MIL STD 810C 514.2
<b>Shock</b>	MIL STD 810C 516.2
<b>Noise Immunity</b>	NEMA ICS3-304
<b>Terminal Type (included)</b>	Removable; D2-8IOCON

**Notes:**

1. The three wires connecting the RTD to the module must be the same type and length. Do not use the shield or drain wire for the third connection.
2. If an RTD sensor has four wires, the plus sense wire should be left unconnected as shown.

Note 1

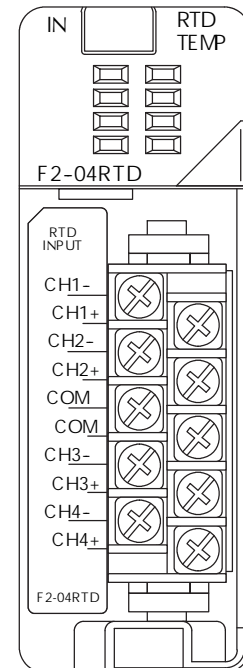
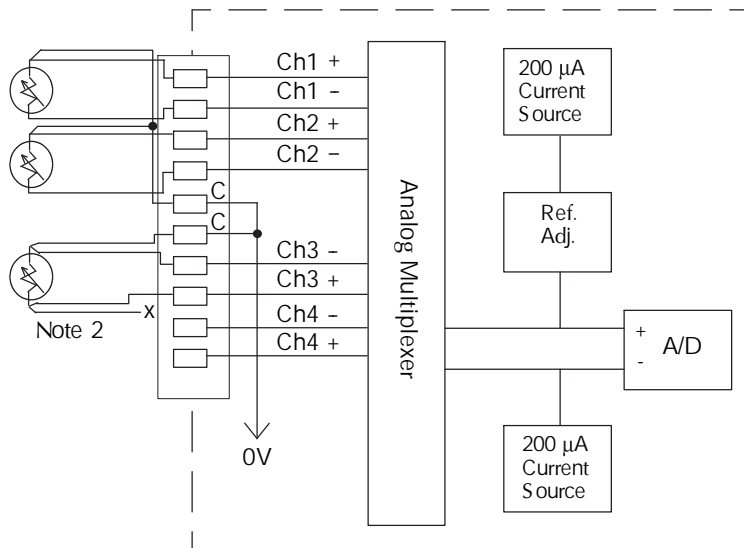

- PLC Overview
- DL05/06 PLC
- DL105 PLC
- DL205 PLC**
- DL305 PLC
- DL405 PLC
- Field I/O
- Software
- C-more HMIs
- Other HMI
- AC Drives
- Motors
- Steppers/Servos
- Motor Controls
- Proximity Sensors
- Photo Sensors
- Limit Switches
- Encoders
- Current Sensors
- Pushbuttons/Lights
- Process
- Relays/Timers
- Comm.
- TB's & Wiring
- Power
- Circuit Protection
- Enclosures
- Appendix
- Part Index