

# Analog Current Input Modules

F2-08AD-1 8-Channel 4-20mA Analog In <---->	
<b>Number of Channels</b>	8, single ended (1 common)
<b>Input Ranges</b>	4 to 20 mA current
<b>Resolution</b>	12 bit (1 in 4096)
<b>Low-pass Filtering</b>	-3dB at 200 Hz, (-6dB per octave)
<b>Input Impedance</b>	250Ω ±0.1%, 1/2W current input
<b>Absolute Maximum Ratings</b>	-45 mA to +45 mA
<b>Converter Type</b>	Successive approximation
<b>Conversion Time (PLC Update Rate)</b>	(D2-230 CPU) 1 channel per scan maximum (D2-240, D2-250(-1) and D2-260 CPUs) 8 channels per scan maximum
<b>Linearity Error (End to End)</b>	±1 count (0.025% of full scale) maximum
<b>Input Stability</b>	±1 count
<b>Full Scale Calibration Error (offset error not included)</b>	±5 counts max., @ 20 mA current input
<b>Offset Calibration Error</b>	±2 counts max., @ 4mA current input
<b>Step Response</b>	7ms to 95% of F.S. change

<b>Maximum Inaccuracy</b>	±.1% @ 77°F (25°C) ±.25% 32° to 140°F (0° to 60°C)
<b>Accuracy vs. Temperature</b>	±50 ppm/°C maximum full scale (including max. offset change of two counts)
<b>Recommended Fuse</b>	0.032A, Series 217 fast-acting, current inputs
<b>Digital Input Points Required</b>	16 (X) input points (12 binary data bits, 3 channel ID bits, 1 broken transmitter bit)
<b>Base Power Required 5VDC</b>	50 mA
<b>External Power Supply</b>	80 mA maximum, +18 to +30 VDC
<b>Operating Temperature</b>	32° to 140°F (0° to 60°C)
<b>Storage Temperature</b>	-4° to 158°F (-20° to 70°C)
<b>Relative Humidity</b>	5 to 95% (non-condensing)
<b>Environmental Air</b>	No corrosive gases permitted
<b>Vibration</b>	MIL STD 810C 514.2
<b>Shock</b>	MIL STD 810C 516.2
<b>Noise Immunity</b>	NEMA ICS3-304
<b>Terminal Type (included)</b>	Removable; D2-810CON

One count in the specification table is equal to one least significant bit of the analog data value (1 in 4096).

Note 1: Shields should be grounded at the signal source.

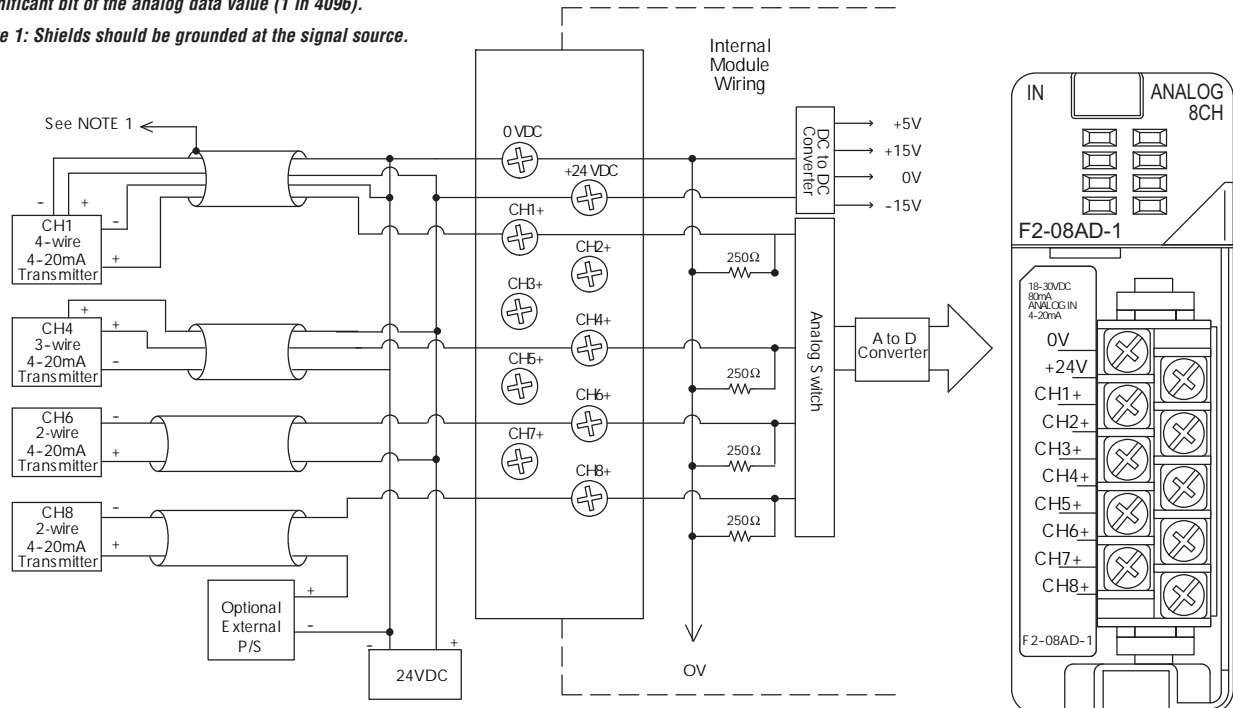

More than one external power supply can be used provided all the power supply commons are connected. A Series 217, 0.032A, fast-acting fuse is recommended for 4-20 mA current loops. If the power supply common of an external power supply is not connected to 0 VDC on the module, then the output of the external transmitter must be isolated. To avoid "ground loop" errors, recommended 4-20 mA transmitter types are:

- 2 or 3 wire: Isolation between input signal and power supply.
- 4 wire: Isolation between input signal, power supply, and 4-20 mA output

- PLC Overview
- DL05/06 PLC
- DL105 PLC
- DL205 PLC**
- DL305 PLC
- DL405 PLC
- Field I/O
- Software
- C-more HMIs
- Other HMI
- AC Drives
- Motors
- Steppers/Servos
- Motor Controls
- Proximity Sensors
- Photo Sensors
- Limit Switches
- Encoders
- Current Sensors
- Pushbuttons/Lights
- Process
- Relays/Timers
- Comm.
- TB's & Wiring
- Power
- Circuit Protection
- Enclosures
- Appendix
- Part Index