

Temperature Input Modules

F4-08RTD 8-Channel RTD Input <--->	
Number of Channels	8
Input Ranges	Type Pt100: -200/850°C, -328/1562°F Type Pt1000: -200/595°C, -328/1103°F Type jPT100: -38/450°C, -36/842°F Type CU-10/25W: -200/260°C, -328/500°F
Resolution	16 bit (1 in 65535)
Input Impedance	27K Ω
Display Resolution	± 0.1°C, ±0.1°F (±3276.7)
RTD Excitation Current	200μA
Input Type	Differential
Notch Filter	>100db notches at 50/60Hz -3db=13.1 Hz
Maximum Settling Time	100msec (full-scale step input)
Common Mode Range	0-5 VDC

Absolute Maximum Ratings	Fault protected inputs to ±50 VDC
Converter Type	Charge Balancing
Linearity Error	± 1°C maximum, ±0.1°C typical
Full Scale Calibration Error	± 1°C
PLC Update Rate	1 ch. per scan min., 8 per scan max.
Digital Input Points Required	32 (X) input points (15 binary data bits, 3 channel ID bits, 1 sign bit, 8 fault bits)
Base Power Required 5V	80mA @ 5VDC
Terminal Type (included)	Removable (D4-16IOCON)
Operating Temperature	32° to 140°F (0 to 60°C)
Storage Temperature	-4 to 158°F (-20 to 70° C)
Relative Humidity	5 to 95% (non-condensing)
Environmental Air	No corrosive gases permitted
Vibration	MIL STD 810C 514.2
Shock	MIL STD 810C 516.2
Noise Immunity	NEMA ICS3-304

Notes:
 1. the three wires connecting the RTD to the module must be the same type and length. Do not use the shield or drain wire for the third connection.
 2. If an RTD sensor has 4 wires, the plus sense wire should be left unconnected as shown.
 3. This module is not compatible with the **ZiLink** wiring system.

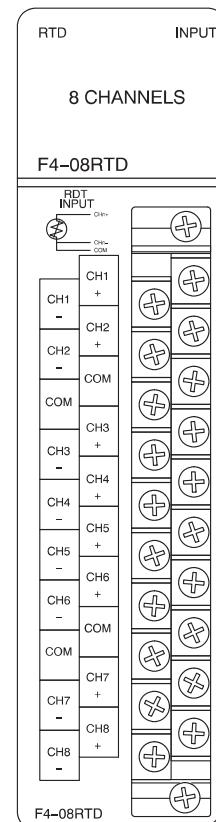
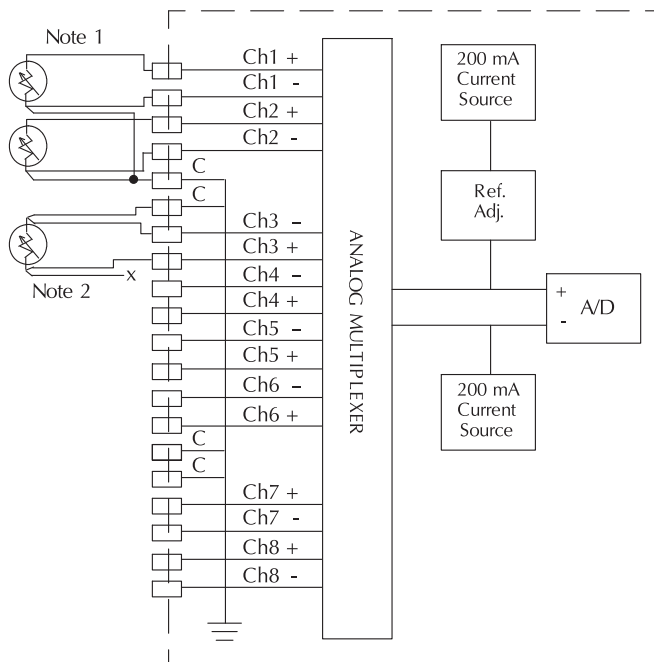

Check the Power Budget

Verify your power budget requirements

Your I/O configuration choice can be affected by the power requirements of the I/O modules you choose. When determining the types and quantity of I/O modules you will be using, it is important to remember there is a limited amount of power available from the power supply.

The chart on the opposite page indicates the power supplied and used by each DL405 device. The adjacent chart shows an example of how to calculate the power used by your particular system. These two charts should make it easy for you to determine if the devices you have chosen fit within the power budget of your system configuration.

If the I/O you have chosen exceeds the maximum power available from the power supply, you can resolve the problem by shifting some of the modules to an expansion base or remote I/O base (if you are using remote I/O).

Warning: It is extremely important to calculate the power budget correctly. If you exceed the power budget, the system may operate in an unpredictable manner which may result in a risk of personal injury or equipment damage.

Use ZIPLinks to reduce power requirements

If your application requires a lot of relay outputs, consider using the ZipLink AC or DC relay output modules. These modules can switch high current (10A) loads without putting a load on your base power budget. Refer to Wiring System for DL405 PLCs later in this section for more information.

This logo is placed next to I/O modules that are supported by the ZIPLink connection systems.

See the I/O module specifications at the end of this section.



Calculating your power usage

The following example shows how to calculate the power budget for the DL405 system. The example is constructed around a single 8-slot base using the devices shown. It is recommended you construct a similar table for each base in your system.

A			
<i>Base Number</i>	<i>Device Type</i>	<i>5 VDC (mA)</i>	<i>External 24 VDC Power (mA)</i>
0			
B CURRENT SUPPLIED			
<i>CPU/Expansion Unit /Remote Slave</i>	D4-440 CPU	3700	400
C CURRENT REQUIRED			
<i>SLOT 0</i>	D4-16ND2	+150	+0
<i>SLOT 1</i>	D4-16ND2	+150	+0
<i>SLOT 2</i>	F4-04DA	+120	+100
<i>SLOT 3</i>	D4-08ND3S	+100	+0
<i>SLOT 4</i>	D4-08ND3S	+100	+0
<i>SLOT 5</i>	D4-16TD2	+100	+0
<i>SLOT 6</i>	D4-16TD2	+100	+0
<i>SLOT 7</i>	D4-16TR	+1000	+0
D OTHER			
<i>BASE</i>	D4-08B	+80	+0
<i>Handheld Programmer</i>	D4-HPP	+320	+0
E Maximum Current Required		2820	100
F Remaining Current Available		3700-2820=880	400-100=300
1. Using a chart similar to the 3 one above, fill in column 2. 2. Using the tables on the opposite page, enter the current supplied and used by each device (columns 3 and 4). Pay special attention to the current supplied by the CPU, Expansion Unit, and Remote Slave since they differ. Devices which fall into the "Other" category (Row D) are devices such as the Base and the Handheld programmer, which also have power requirements, but do not plug directly into the base. 3. Add the current used by the system devices (columns 3 and 4) starting with Slot 0 and put the total in the row labeled "maximum current required" (Row E). 4. Subtract the row labeled "Maximum current required" (Row E), from the row labeled "Current Supplied" (Row B). Place the difference in the row labeled "Remaining Current Available" (Row F). 5. If "Maximum Current Required" is greater than "Current Supplied" in either column 3 or 4, the power budget will be exceeded. It will be unsafe to use this configuration and you will need to restructure your I/O configuration. Note the auxiliary 24 VDC power supply does not need to supply all the external power. If you need more than the 400mA supplied, you can add an external 24VDC power supply. This will help keep you within your power budget for external power.			

DL405 CPU power supply specifications and power requirements

Specification	AC Powered Units	24 VDC Powered Units	125 VDC Powered Units
Part Numbers	D4-450, D4-440, D4-430, D4-EX (expansion base unit), D4-RS (remote slave unit)	D4-450DC-1, D4-440DC-1, D4-EXDC (expansion base unit), D4-RSDC (remote slave unit)	D4-450DC-2, D4-440DC-2
Voltage Withstand (dielectric)	1 minute @ 1,500 VAC between primary, secondary, field ground, and run relay		
Insulation Resistance	> 10MΩ at 500VDC		
Input Voltage Range	85-132 VAC (110 range) 170-264 VAC (220 range)	20-28 VDC (24 VDC) with less than 10% ripple	90-146 VDC (125 VDC) with less than 10% ripple
Maximum Inrush Current	20 A	20 A	20 A
Maximum Power	50 VA	38 W	30 W

Power Requirements



Company Information

Systems Overview

Programmable Controllers

Field I/O

Software

C-more & other HMI

Drives

Soft Starters

Motors & Gearbox

Steppers/Servos

Motor Controls

Proximity Sensors

Photo Sensors

Limit Switches

Encoders

Current Sensors

Pressure Sensors

Temperature Sensors

Pushbuttons/Lights

Process

Relays/Timers

Comm.

Terminal Blocks & Wiring

Power

Circuit Protection

Enclosures

Tools

Pneumatics

Safety

Appendix

Product Index

Part # Index

Power Supplied					
CPUs/Remote Units/Expansion Units	5 VDC Current Supplied in mA	24V Aux Power Supplied in mA	CPUs/Remote Units/Expansion Units	5V Current Supplied in mA	24VAux. Power Supplied in mA
D4-430 CPU	3700	400	D4-EX	4000	400
D4-440 CPU	3700	400	D4-EXDC	4000	NONE
D4-440DC-1 CPU	3700	NONE	D4-EXDC-2	3700	NONE
D4-440DC-2 CPU	3700	NONE	D4-RS	3700	400
D4-450 CPU	3100	400	D4-RSDC	3700	NONE
D4-450DC-1 CPU	3100	NONE	H4-EBC	3470	400
D4-450DC-2 CPU	3100	NONE	H4-EBC-F	3300	400
Power Consumed					
Power-consuming Device	5V Current Consumed	External 24VDC Current Required	Power-consuming Device	5V Current Consumed	External 24VDC Current Required
I/O Bases			Analog Modules (continued)		
D4-04B-1	80	NONE	F4-16AD-1	75	100
D4-06B-1	80	NONE	F4-16AD-2	75	100
D4-08B-1	80	NONE	F4-04DA-1	70	75+20per circuit
			F4-04DA-2	90	90
			F4-04DAS-1	60	60 per circuit
			F4-04DAS-2	60	60 per circuit
			F4-08DA-1	90	100+20 per circuit
			F4-08DA-2	80	150
			F4-16DA-1	90	100+20 per circuit
			F4-16DA-2	80	25 max.
			F4-08RTD	80	NONE
			F4-08THM-n	120	50
			F4-08THM	110	60
DC Input Modules			Remote I/O		
D4-08ND3S	100	NONE	H4-ERM	320	NONE
D4-16ND2	150	NONE	H4-ERM-F	450	NONE
D4-16ND2F	150	NONE	D4-RM	300	NONE
D4-32ND3-1	150	NONE			
D4-32ND3-2	150	NONE			
D4-64ND2	300 max.	NONE			
AC Input Modules			Communications and Networking		
D4-08NA	100	NONE	H4-ECOM100	300	NONE
D4-16NA	150	NONE	H4-ECOM-F	670	NONE
			D4-DCM	500	NONE
			F4-MAS-MB	235	NONE
			FA-UNICON	NONE	65
AC/DC Input Modules			CoProcessors		
D4-16NE3	150	NONE	F4-CP128-1	305	NONE
F4-08NE3S	90	NONE			
DC Output Modules			Specialty Modules		
D4-08TD1	150	35	H4-CTRIO	400	NONE
F4-08TD1S	295	NONE	D4-INT	100	NONE
D4-16TD1	200	125	D4-HSC	300	NONE
D4-16TD2	400	NONE	F4-16PID	160	NONE
D4-32TD1	250	140	F4-8MPI	225	170
D4-32TD1-1	250	140 (15V)	D4-16SIM	150	NONE
D4-32TD2	350	120 (4A max including loads)	F4-4LTC	280	75
D4-64TD1	800	NONE			
AC Output Modules			Programming		
D4-08TA	250	NONE	D4-HPP-1 (Handheld Prog.)	320	NONE
D4-16TA	450	NONE			
Relay Output Modules			Operator Interface		
D4-08TR	550	NONE	DV-1000	150	NONE
F4-08TRS-1	575	NONE			
F4-08TRS	575	NONE	C-more Micro-Graphic	210	NONE
D4-16TR	1000	NONE			
Analog Modules			C-more		
F4-04AD	85	100			
F4-04ADS	270	120			
F4-08AD	75	90			