

Analog Input Modules

F4-16AD-1 16-Channel Analog Current Input <-->	
Number of Channels	16, single ended (one common)
Input Ranges	0-20mA, 4-20mA
Channels Individually Configurable	No. Each channel can be configured for current or voltage but must be same range.
Resolution	12 bit (1 to 4,096)
Active Low-pass Filtering	-3dB at 20Hz, -12 dB per octave
Input Impedance	250Ω ± 0.1%, 1/2W current input >20MΩ voltage input 1 MΩ minimum
Absolute Maximum Ratings	-45mA to + 45mA, current input -75V to +75V, voltage input
Conversion Time	2ms per channel (module conversion)
Linearity Error (End to End)	± 2 count (0.025% of full scale) max.
Input Stability	± 1 count
Full Scale Calibration Error (Offset error not included)	± 12 counts max. @ 20mA current input
Offset Calibration Error	± 3 counts max., 4mA current input

PLC Update Rate	1 channel per scan min., 16 per scan, max.
Digital Input Points Required	16 (X) input points (12 binary data bits, 4 active channel bits)
Base Power Required 5V	100mA
Terminal Type (included)	Removable (D4-1610CON)
External Power Supply	21.6-26.4VDC, 100mA, class2
Recommended Fuse	0.032 A, Series 217 fast-acting, current inputs
Operating Temperature	32° to 140°F (0 to 60°C)
Accuracy vs. Temperature	± 50 ppm/°C maximum full scale (including maximum offset change of 2 counts)
Storage Temperature	-4 to 158°F (-20 to 70° C)
Relative Humidity	5 to 95% (non-condensing)
Environmental Air	No corrosive gases permitted
Vibration	MIL STD 810C 514.2
Shock	MIL STD 810C 516.2
Noise Immunity	NEMA ICS3-304

One count in the specification table is equal to one least significant bit of the analog data value (1 in 4096).
NOTE 1: Shields should be grounded at the signal source.
A Series 217, 0.032A, fast-acting fuse is recommended for 4-20mA current loops.
If the power supply common of an external power supply is not connected to 0VDC on the module, then the output of the external transmitter must be isolated.
To avoid "ground loop" errors, recommended 4-20mA transmitter types are:
2 or 3 wire: Isolation between input signal and power supply.
4 wire: Isolation between input signal, power supply and 4-20mA output.

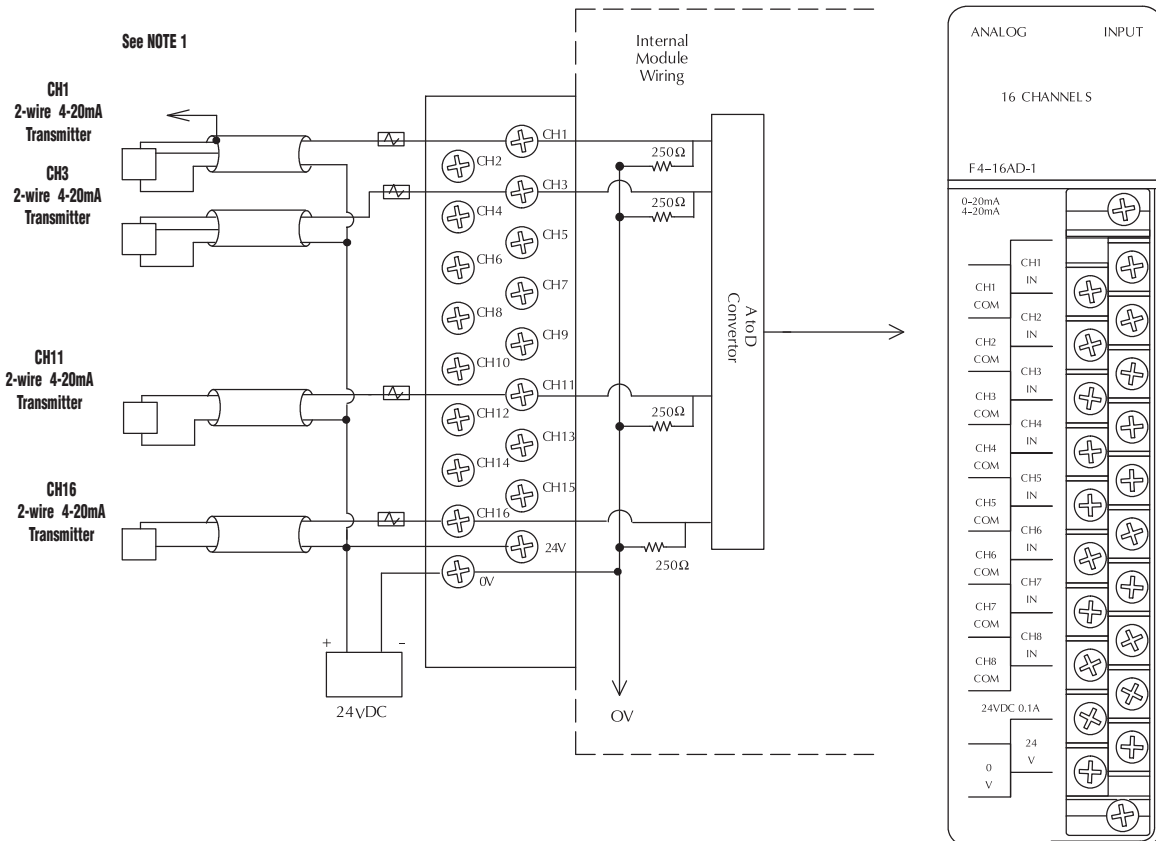

- PLC Overview
- DL05/06 PLC
- DL105 PLC
- DL205 PLC
- DL305 PLC
- DL405 PLC**
- Field I/O
- Software
- C-more HMIs
- Other HMI
- AC Drives
- Motors
- Steppers/Servos
- Motor Controls
- Proximity Sensors
- Photo Sensors
- Limit Switches
- Encoders
- Current Sensors
- Pushbuttons/Lights
- Process
- Relays/Timers
- Comm.
- TB's & Wiring
- Power
- Circuit Protection
- Enclosures
- Appendix
- Part Index