

# RHINO DC to DC Isolated Converter

This isolated DC to DC power supply is used for eliminating ground loops or addressing isolation issues when interfacing to PLC analog I/O modules. The design features handle many types of configuration problems. The FA-DCDC-1 is a DIN-rail mount,  $\pm 10\text{VDC}$ ,  $\pm 5\text{VDC}$  isolated power supply, with each output rated at 125mA. The  $\pm 10\text{V}$  and  $\pm 5\text{V}$  outputs are fixed at 1.0% regulation. The input voltage range is 12-24V DC  $\pm 15\%$  at approximately 6.7 Watts.

FA-DCDC-1



FA-DCDC-1 General Specifications <sup>1</sup>	
<b>Input Voltage Range</b>	12V to 24VDC $\pm 15\%$
<b>Input Power<sup>2</sup></b>	6.7 Watts, Vin 27.6V, 125mA load each channel
<b>Output Voltage<sup>3</sup> (25°C)</b>	+5V $\pm 1\%$ , 125mA load, -5V $\pm 1\%$ 125mA load +10V $\pm 1\%$ 125mA load, -10V $\pm 1\%$ 125mA load
<b>Output Current</b>	125mA (per output voltage)
<b>Output Ripple</b>	$\pm 5\text{V}$ channels: <10mV peak to peak, Vin 10.2V 125mA load on both channels $\pm 10\text{V}$ channels: <25mV peak to peak, Vin 10.2V, 125mA load on both channels
<b>Line Regulation<sup>4</sup></b>	$\pm 5\text{V}$ channels: <10mV, Vin 10.2V to 27.6V, 125mA load on both channels $\pm 10\text{V}$ channels: <20mV, Vin 10.2V to 27.6V, 125mA load on both channels
<b>Load Regulation<sup>5</sup></b>	$\pm 5\text{V}$ channels: <20mV, Vin 10.2V, 0 - 125mA load variation $\pm 10\text{V}$ channels: <40mV, Vin 10.2V, 0 - 125mA load variation
<b>Isolation</b>	<b>Input to Output: 1500V; <math>\pm 5\text{V}</math> to <math>\pm 10\text{V}</math>: 1500V</b>
<b>Inrush Current (50ms)</b>	970mA, Vin 10.2V, 125mA load all channels
<b>Holdup Time (all channels)</b>	30mS minimum, Vin 10V, 125mA load all channels
<b>Overshoot Protection</b>	No overshoot - Turn on and turn off of Vin
<b>Input Protection (reverse DC input voltage)</b>	Up to -50V reverse. $\pm$ Vin reverse polarity connection.
<b>Overload Protection</b>	Auto shutdown. Short circuit. Cycle Vin post event
<b>Output Protection</b>	Indefinite duration. $\pm 5\text{V}$ tied to $\pm 10\text{V}$
<b>Peak Line Transient Voltage</b>	100V for 10mS. Voltage spike on input
<b>Operating Temperature</b>	0 to 60°C (32 to 140°F) full rated
<b>Storage Temperature</b>	-20 to 70°C (-4 to 158°F)
<b>Enclosure</b>	Clear Lexan 221-111 with UN5016 transparent blue colorant
<b>Mounting</b>	35mm wide DIN rail: part # DN-R35S1 or DN-35HS1; surface mount
<b>Connection</b>	5mm screw terminal
<b>Relative Humidity</b>	5 to 90% (non-condensing)
<b>Environmental Air</b>	No corrosive gases permitted
<b>Vibration</b>	MIL STD 810C 514.2
<b>Shock</b>	MIL STD 810C 516.2
<b>Noise Immunity</b>	NEMA ICS3-304
<b>Agency Standards and Approvals</b>	UL/cUL listed, UL file E200031, UL508/CSA - C22.2 No. 142-M1987 for ordinary locations. Class I, Division 2, Groups A, B, C, D Hazardous Locations

**Notes:** 1. All specifications are over the full operating temperature range (0°C to 60°C) unless stated otherwise.  
 2. "Channel" means Output Voltage. For example: +5V is one channel and -10V is another.  
 3. All output voltage channels are independent of each other. Changing loading on one will have no effect on the other voltage outputs.  
 4. LINE Regulation: varying the Input Voltage over entire range (12V to 24V  $\pm 15\%$ ) and the resultant change in the Output Voltage(s) under worst case load conditions (all output channels drawing 125mA).  
 5. LOAD Regulation: varying the output loads from no-load to a worst case 125mA load and measuring the resultant change in the Output Voltage(s) under a worst case minimum Input Voltage (10.2V) condition.

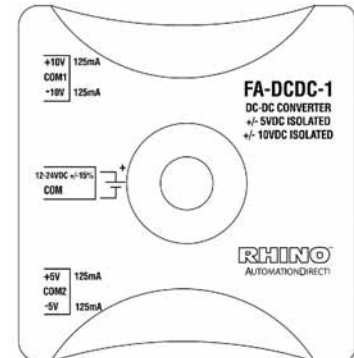
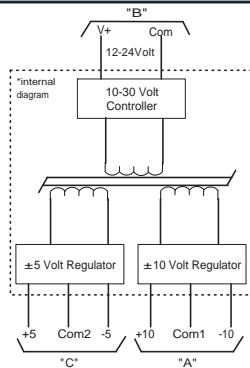

# RHINO DC to DC Isolated Converter

## Applications

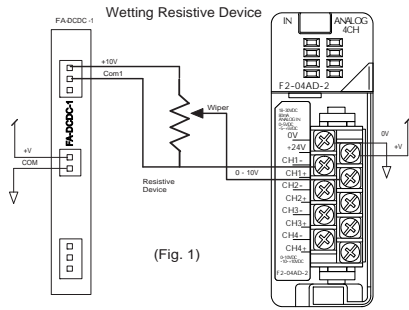

(Fig. 1)

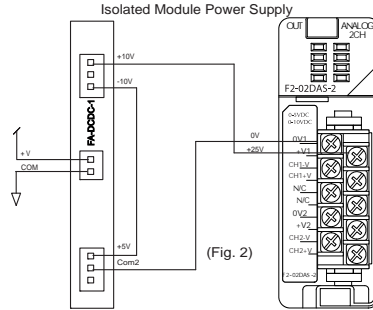

(Fig. 2)

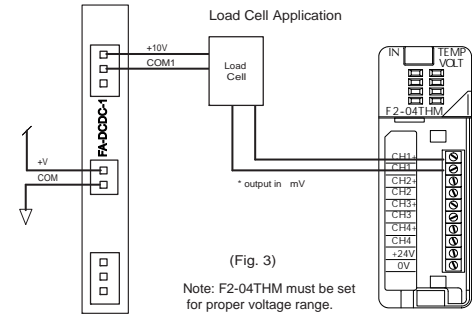

(Fig. 3)

When using a linear potentiometer, the +10V connects to the high side of the potentiometer and the COM1 becomes the zero volt reference. The wiper connects to the analog input. The result is 0 to 10V at the analog module input. (Fig. 1)

Use in a solar/battery application where unregulated 12VDC is available and the analog module requires 24VDC for operation, connect the +10V to +24V module power, connect the -10V to the +5V and the COM2 to the 0V module power. (Fig. 2)

Use to power a load cell application. (Fig. 3)

Note: F2-04THM must be set for proper voltage range.

THIS EQUIPMENT IS SUITABLE FOR USE IN CLASS I, DIVISION 2/ZONE 2, GROUPS A, B, C AND D NON-HAZARDOUS LOCATIONS ONLY.



**WARNING - EXPLOSION HAZARD - SUBSTITUTION OF COMPONENTS MAY IMPAIR SUITABILITY FOR CLASS I, DIVISION 2/ZONE 2.**



**WARNING - EXPLOSION HAZARD - DO NOT CONNECT OR DISCONNECT CONNECTORS OR OPERATE SWITCHES WHILE CIRCUIT IS LIVE UNLESS THE AREA IS KNOWN TO BE NON HAZARDOUS.**

## Dimensions, in(mm)

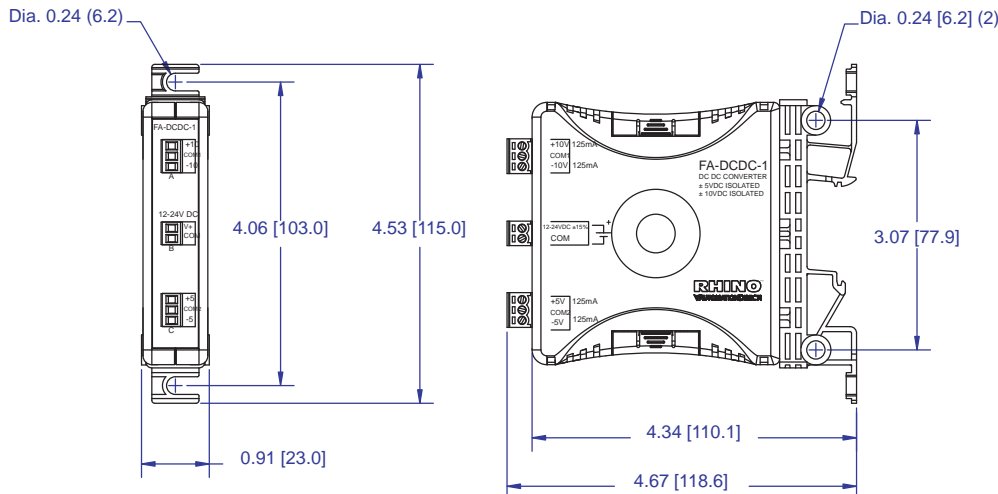

- Company Information
- Systems Overview
- Programmable Controllers
- Field I/O
- Software
- C-more & other HMI
- Drives
- Soft Starters
- Motors & Gearbox
- Steppers/ Servos
- Motor Controls
- Proximity Sensors
- Photo Sensors
- Limit Switches
- Encoders
- Current Sensors
- Pressure Sensors
- Temperature Sensors
- Pushbuttons/ Lights
- Process
- Relays/ Timers
- Comm.
- Terminal Blocks & Wiring
- Power
- Circuit Protection
- Enclosures
- Tools
- Pneumatics
- Safety
- Appendix
- Product Index
- Part # Index