

# Fuji Molded Case Circuit Breakers Overview

## Overview

Fuji Molded Case Circuit Breakers are more compact (especially 100A, 125A, 250A frames) than any breakers on the market, so they take up less space in control panels.

This product group maintains conformity to all Worldwide standards.

## Agency Approvals

- UL listed, MCCB, File: E90584
- UL listed, Accessories, File E93289
- CE marked
- CCC marked
- TUV certified

## Standards

- UL 489
- CSA C22.2 No.5
- IEC 60947-2
- EN 60947-2
- GB 14048.2
- JIS C8201-2-1, 2 (ANN.1, 2)

## Features

- Thermal-magnetic 15A through 800A
- Suitable for branch circuit protection
- Rated current of 15 to 800A, max 600V
- Standard type and high-interrupting capacities available in identically sized breakers
- Shunt Trip, Undervoltage Release and other accessories available
- Line and load lug terminals included on all MCCBs
- Auxiliary switch, Alarm switch and Shunt Trip can be installed in the field
- Door-mounted or flange-mounted, flex shaft operating handles
- All frame sizes suitable for reverse-feed applications
- All breakers include mounting hardware
- Terminal covers included for BW125 and BW250 frames. Terminal covers available for BW400, BW630 and BW800 frames.



Fuji Electric Molded Case Circuit Breakers Technical Specifications

Circuit Breaker Type	Ampere Rating at 40°C	No. Poles	Volts		Type of Trip*	UL 489 Interrupting Ratings (rms Symmetrical Amperes) (kA)			
			AC	DC		Volts AC (50/60 Hz)			Volts DC
						240	480	600	
<b>BW125JAGU</b>	15-125	3	600	250	N.I.T.U	50	30	10	10
<b>BW250JAGU</b>	125-250	3	600	250	N.I.T.U	50	30	10	10
<b>BW400SAGU</b>	250-400	3	480	250	N.I.T.U	50	35	–	10
<b>BW630RAGU</b>	500-600	3	480	250	N.I.T.U	100	50	–	10
<b>BW800RAGU</b>	700-800	3	480	250	N.I.T.U	100	50	–	10

\*Note: N.I.T.U denotes non-interchangeable trip unit.

\*\*Note: For DC or 1-phase AC applications, use the two outside poles of the 3-pole circuit breaker

# Fuji Molded Case Circuit Breakers – 800A Frame



Fuji BW800A series MCCBs are 800 amp frame, 3-pole, non-adjustable magnetic trip, molded case circuit breakers (MCCB). The BW800 series is suitable for reverse feed

applications. Included with each MCCB are Line and Load-side lug terminals and mounting hardware. Accessories are not pre-installed and are sold separately.

## BW800RAGU-3P700SB shown

BW800-Frame Series Three-Pole Molded Case Circuit Breakers									
Part Number	Price	Frequency	Rated Interrupting Capacity (kA)						
			Rated Current	UL489 CAN/CSA C22.2 No. 5		IEC60947-2, JIS C 8201-2-1 Icu/Ics		GB14048.2 Icu/Ics	
			Ampere Rating	Voltage	Interrupt Capacity	Voltage	Interrupt Capacity	Voltage	Interrupt Capacity
<b>BW800RAGU-3P700SB</b>	<-->	50/60 Hz	700	480V/Δ AC	50 kA	690V AC	15/8 kA	400V AC	50/25 kA
<b>BW800RAGU-3P800SB</b>	<-->			800					
				240V AC	10 kA	440V AC	50/25 kA		
				250V DC		400V AC	50/25 kA		
						380V AC	50/25 kA		
						240V AC	100/50 kA		
						250V DC	40/20 kA		

Note: SCCR = UL489 interrupting capacity

BW800-Frame Accessory Selection Guide		
Part Number	Price	Description
<b>BW9W1SHA</b>	<-->	Field installable auxiliary contact switch, use with BW400, BW630 and BW800 series MCCBs. SPDT. 20AWG lead wires, 19.69" long, left side mount only
<b>BW9FHA-R</b>	<-->	Field installable DC shunt trip, use with BW400, BW630 and BW800 series MCCBs; 24 VDC/AC, 20 AWG lead wires 19.69" long, left and right side mount
<b>BW9FHA-A</b>	<-->	Field installable AC shunt trip, use with BW400, BW630 and BW800 series MCCBs; 100-120 VAC, 20 AWG lead wires 19.69" long, left and right side mount
<b>BW9RHA-R</b>	<-->	Field installable DC undervoltage release, for BW400, BW630 and BW800 series MCCBs; 24-48 VDC, 20AWG lead wires, 19.69" long, left side mount only
<b>BW9RHA-1</b>	<-->	Field installable AC undervoltage release, for BW400, BW630 and BW800 series MCCBs; 120-130 VAC, 20AWG lead wires, 19.69" long, left side mount only
<b>BW9BTJA-L3W*</b>	<-->	Terminal cover for BW400-frame MCCBs, line and load side, package of 2
<b>BW9V0JA</b>	<-->	NEMA 12 rotary handle for BW800-Frame. Position indicating; lock-off feature. Shaft length: 0.39"
<b>BZ-VS2</b>	<-->	NEMA 12 rotary handle shaft for BW9V0HA and BW9V0JA, BW400, BW630 and BW800 Frames. Steel shaft length: 3.48" (88 mm)
<b>BZ-VS2-24</b>	<-->	NEMA 12 rotary handle shaft for BW9V0HA and BW9V0JA, BW400, BW630 and BW800 Frames. Steel shaft length: 24" (610 mm)
<b>BW9F0JA-15A**</b>	<-->	NEMA 12 flexible shaft handle for BW630 and BW800 frames. Flange mounted. Lockable. Flex cable shaft length: 4.92' (1.5m)
<b>BW9F0JA-20A**</b>	<-->	NEMA 12 flexible shaft handle for BW630 and BW800 frames. Flange mounted. Lockable. Flex cable shaft length: 6.56' (2m)
<b>BW9QNHA</b>	<-->	Lockout attachment, use to lock out BW400, BW630 and BW800 series MCCBs. Lock not included.

Notes: \*Terminal covers are not supplied as standard.  
\*\*Terminal covers for line side and load side included with Flange Disconnects. 2/pk



BW9V0JA



BW9F0JA-15A



BW9FHA-R



BW9RHA-R



BW9QNHA

Wiring Specifications chart is on page 31-33

# Fuji Molded Case Circuit Breakers – 800A Frame Characteristic Curves

**BW800 Current Range 700 - 800A**

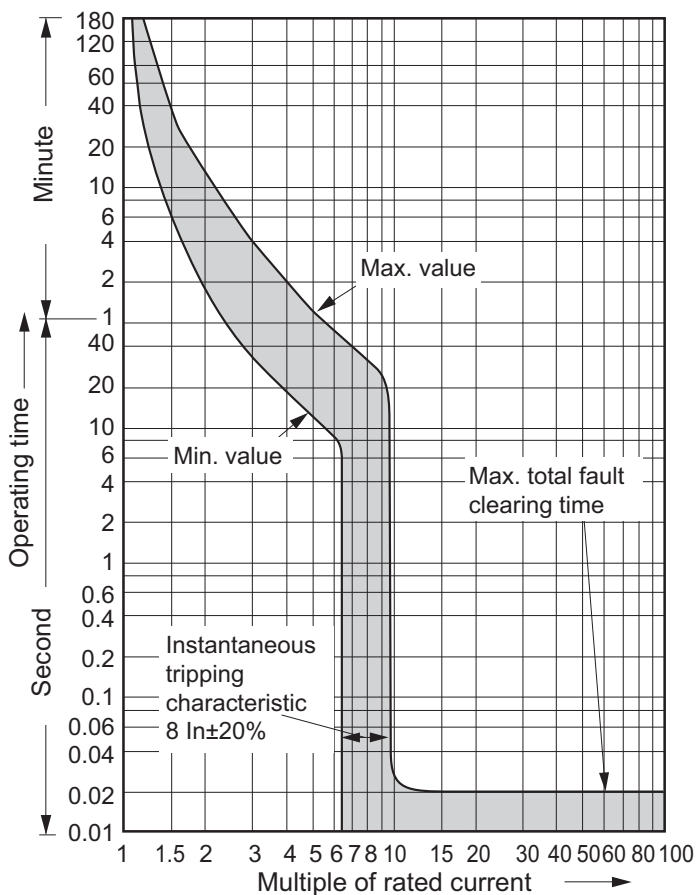

Note: Instantaneous tripping =  $8 \times (\text{rated current}) \pm 20\%$   
 $I_n$  = rated current

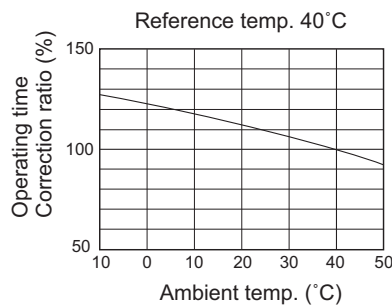

# Fuji Molded Case Circuit Breakers – Dimensions

## Dimensions

Units: mm [inches]

### 700A BW800 Frame

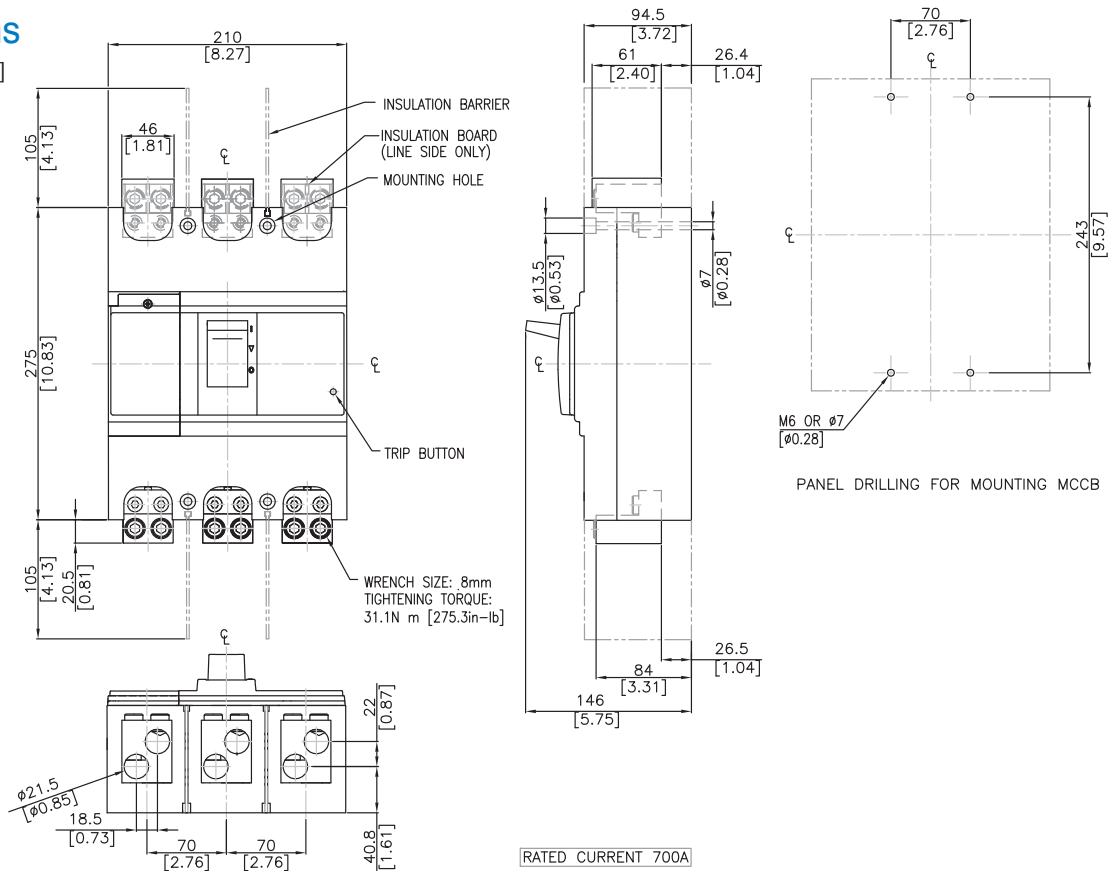

### 800A BW800 Frame

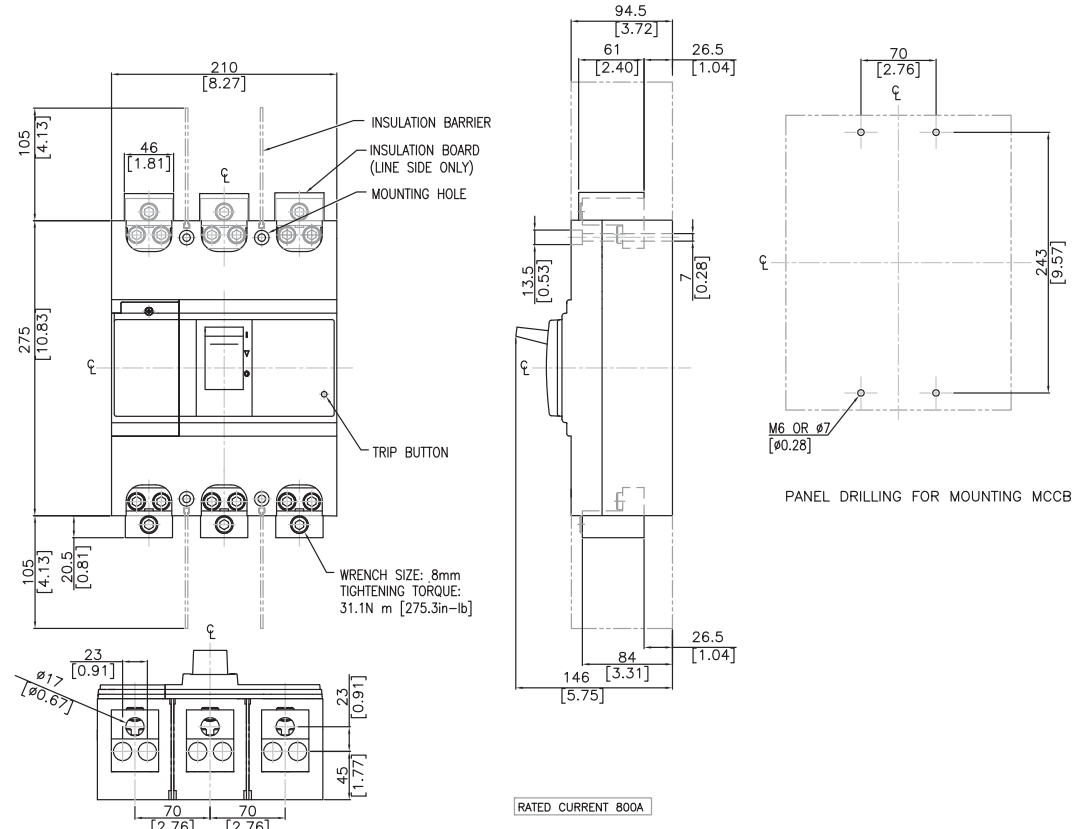

# Fuji Molded Case Circuit Breakers – Products And Accessory Compatibility

Match the Accessories with Fuji Molded Case Circuit Breakers						
Part Number	Description	BW125JAGU	BW250JAGU	BW400SAGU	BW630RAGU	BW800RAGU
<b>BW9W1SG0</b>	Auxiliary Switch (Mounting Left and right side)	X	X			
<b>BW9W1SHA</b>	Auxiliary Switch (Mounting Left side ONLY)			X	X	X
<b>BW9FRG0</b>	Shunt Trip 24 VAC/VDC (Mounting both Left and Right sides)	X	X			
<b>BW9FHA-R</b>	Shunt Trip 24-48 VAC/VDC (Mounting Left side ONLY)			X	X	X
<b>BW9FAG0</b>	Shunt Trip 100-120 VAC, 100-110 VDC (Mounting both Left and Right sides)	X	X			
<b>BW9FHA-A</b>	Shunt Trip 100-280 VAC, 100-220 VDC (Mounting Left side ONLY)			X	X	X
<b>BW9RGAR</b>	UnderVoltage Release 24VDC (Left side ONLY)	X	X			
<b>BW9RHA-R</b>	UnderVoltage Release 24 VAC/VDC (Left side ONLY)			X	X	X
<b>BW9RGAT</b>	UnderVoltage Release 110-130 VAC (Left side ONLY)	X	X			
<b>BW9RHA-1</b>	UnderVoltage Release 120-130 VAC, 125VDC (Left side ONLY)			X	X	X
<b>BW9SLOCA-3</b>	Replacement Lugs Kit for 125 Amp frame	X				
<b>BW9SLOGA-3</b>	Replacement Lugs Kit for 250 Amp frame up to 175A		X			
<b>BW9SL1GA-3</b>	Replacement Lugs Kit for 250 Amp frame 200A to 250A		X			
<b>BW9V0CA</b>	Rotary Handle	X				
<b>BW9V0GA</b>	Rotary Handle		X			
<b>BW9VSG0</b>	Optional Shaft for BW9V0CA and BW9V0GA, 6.063"	X	X			
<b>BW9VSG0-24</b>	Optional Shaft for BW9V0CA and BW9V0GA, 24"	X	X			
<b>BW9V0HA</b>	Rotary Handle,			X		
<b>BW9V0JA</b>	Rotary Handle,				X	X
<b>BZ-VS2</b>	Optional Shaft for BW9V0HA and BW9V0JA, 3.48"			X	X	X
<b>BZ-VS2-24</b>	Optional Shaft for BW9V0HA and BW9V0JA, H = 24"			X	X	X
<b>BW9F0CA-15A</b>	Flange Handle (flex shaft), NEMA 12, 59" (1.5m) cable, 125 Amp frame	X				
<b>BW9F0CA-20A</b>	Flange Handle (flex shaft), NEMA 12, 78.7" (2.0m) cable, 125 Amp frame	X				
<b>BW9F0GA-15A</b>	Flange Handle (flex shaft), NEMA 12, 59" (1.5m) cable, 250 Amp frame		X			
<b>BW9F0GA-20A</b>	Flange Handle (flex shaft), NEMA 12, 78.7" (2.0m) cable, 250 Amp frame		X			
<b>BW9F0HA-15A</b>	Flange Handle (flex shaft), NEMA 12, 59" (1.5m) cable, 400 Amp frame			X		
<b>BW9F0HA-20A</b>	Flange Handle (flex shaft), NEMA 12, 78.7" (2.0m) cable, 400 Amp frame			X		
<b>BW9F0JA-15A</b>	Nema 12 flexible shaft handle for 630A or 800A frame. 59.06" (1.5m) cable				X	X
<b>BW9F0JA-20A</b>	Nema 12 flexible shaft handle for 630A or 800A frame. 78.74" (2m) cable				X	X
<b>BW9BTHA-L3W</b>	Terminal Cover for the 400A frame			X		
<b>BW9BTJA-L3W</b>	Terminal Cover for the 630A AND 800A frame				X	X
<b>BW9Q1CA</b>	Lockout Attachment 125A and 250A frames	X	X			
<b>BW9QNHA</b>	Lockout Attachment 400A, 630A and 800A frames			X	X	X

## Internal Accessory Combinations for BW Series



MCCB	BW125 BW250	BW400 BW630 BW800
Pole	3	3
Auxiliary switch	○ □	○ □
SPDT	□ □	□ □
Shunt trip	□ □	□ □
Undervoltage trip	■ □	■ □
Auxiliary Switch + Shunt Trip	○ □ □	○ □ □
Undervoltage + Auxiliary Switch	■ □ ○	■ □ ○

# Fuji Molded Case Circuit Breakers – Wire Range Specifications



## Wiring

- When connecting the wires, follow NEC (National Electric Code, USA) or CEC (Canadian Electrical code Part 1, Canada) instructions.
- Use copper wire rated for 75°C for connecting. UL or CSA approved wire is recommended.
- Tighten the wire connections adequately, as a very large electromagnetic force will be generated when short circuit current is generated.
- Perform additional tightening of the terminal screws periodically.

Allowable Wire Specifications for Lug Terminals	
Wire Size AWG or MCM (mm <sup>2</sup> )	Number of Wire Strands
14 to 2 (2.1 to 33.6)	7
1 to 4/0 (42.4 to 107.2)	19
250 to 500 (127 to 250)	37



### Caution

- Adhere to the allowable number of strands of wire indicated in the table on the left.
- Two wires cannot be connected together to a single connecting hole of lug terminal except BW400SAGU-3P400SB.
- Follow the number of strands of wire indicated on the table. (Wire size and number of wire strands not listed on table can not be connected)
- Do not solder the end of the wire.



Rated current  
15A to 350A



Rated current 400A  
3/0 AWG x 2  
19 strands each

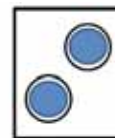

Rated current  
500A to 700A

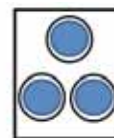

Rated current 800A  
300 MCM x 3  
37 strands each

Maximum Wire Sizes and Tightening Torque			
Type	Rated Current (A)	Wire Size AWG or MCM (mm <sup>2</sup> )	Tightening Torque
			Lug Terminal*
BW125	15	14 AWG (2.1mm <sup>2</sup> )	51 lb.-in. (5.8 N-m)
	20	12 AWG (3.3mm <sup>2</sup> )	
	30	10 AWG (5.3mm <sup>2</sup> )	
	40	8 AWG (8.4mm <sup>2</sup> )	
	50	8 AWG (8.4mm <sup>2</sup> )	
	60	6 AWG (13.3mm <sup>2</sup> )	
	70	4 AWG (21.1mm <sup>2</sup> )	
	75	4 AWG (21.1mm <sup>2</sup> )	
	80	4 AWG (21.1mm <sup>2</sup> )	
	90	3 AWG (26.7mm <sup>2</sup> )	
BW250	100	3 AWG (26.7mm <sup>2</sup> )	204 lb.-in. (23 N-m)
	125	1 AWG (42.4mm <sup>2</sup> )	
	150	1/0 AWG (53.5mm <sup>2</sup> )	
	175	2/0 AWG (67.4mm <sup>2</sup> )	
	200	3/0 AWG (85.0mm <sup>2</sup> )	
	225	4/0 AWG (107.2mm <sup>2</sup> )	
BW400	250	250 MCM (127mm <sup>2</sup> )	385 lb.-in (43.5 N-m)
	300	350 MCM (177mm <sup>2</sup> )	
	350	500 MCM (253mm <sup>2</sup> )	
	400	3/0 AWGx2 (85.0mm <sup>2</sup> x2)	282 lb-in (31.9 N-m)
BW630	500	250 MCMx2	275 lb.-in. (31.07 N-m)
	600	350 MCMx2	
BW800	700	500 MCMx2	275 lb.-in. (31.07 N-m)
	800	300 MCMx3	

\*Note: Lug terminals are supplied as standard.

# Fuji Molded Case Circuit Breakers – Field-mountable Accessories



Rotary Operating Handles for Fuji MCCBs – Selection Guide									
Breaker Type	V-type Handle	Price	V-type Handle	With the optional shaft (x= 3.504 (89))		With the optional shaft (x= 24 (609.6))		Mounting Screw	V-type Handle Mass lb. (kg)
			H: inch(mm)	Max. Mounting Depth H: inch(mm)	Range in which the hinge with H can be installed	Max. Mounting Depth H: inch(mm)	Range in which the hinge with H can be installed		
BW400	BW9V0HA	<--->	7.48±0.078 (190±2)	9.843±0.078 (250±2)	7.95 to 9.843 (202to 250)	30.35±0.078 (771±2)	7.95 - 30.35 (202 - 771)	M4 x 3.35 (85)	1.48 (0.67)
BW630 BW800	BW9V0JA	<--->							

- Notes:
- Handle is an operating mechanism only; not for sealing enclosure door.
  - Not available for side mounting

## Dimensions

Units: inches [mm]

### 400A, 630A, 800A Frame V type handle

- BW9V0HA, BW9V0JA (BZ-VS2, BZ-VS2-24: optional shafts)

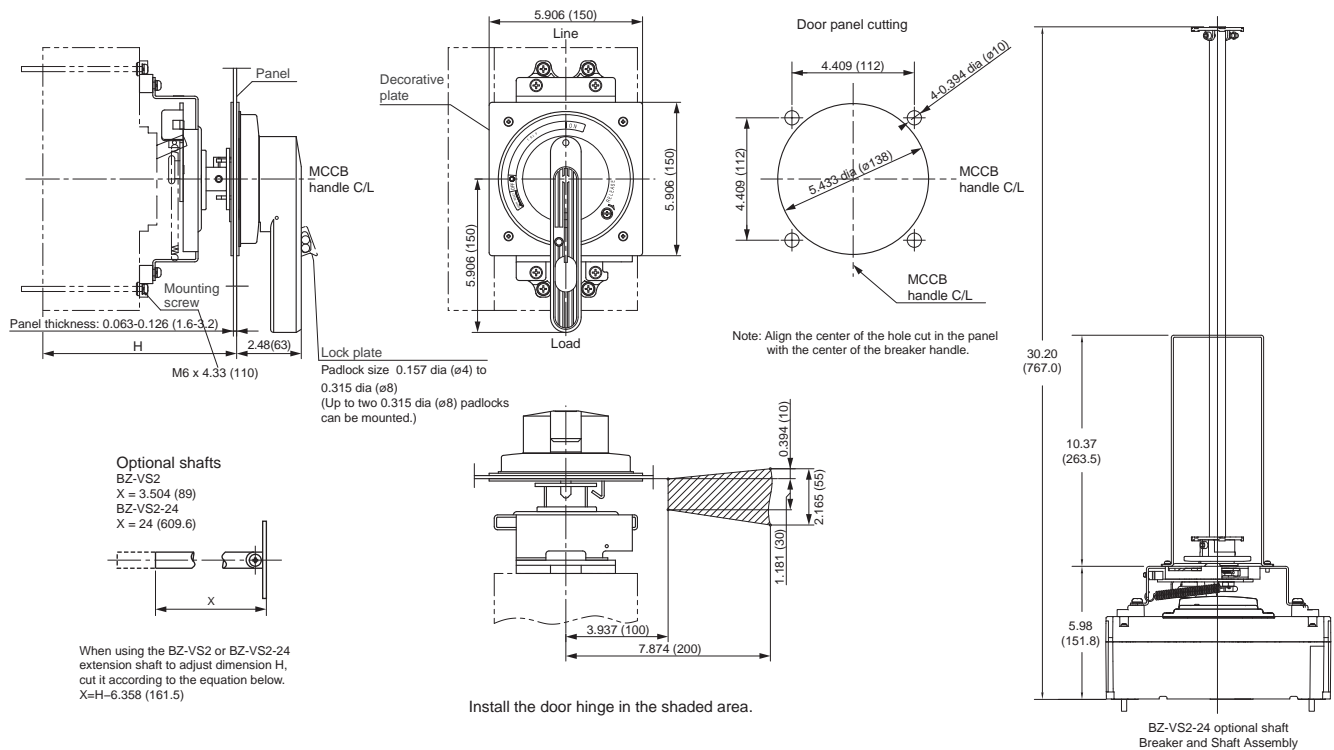

# Fuji Molded Case Circuit Breakers – Field-mountable Accessories

## Defeatable Flexible Handle Operating Mechanisms



BW9F0JA-20A shown

Flex Shaft Handles for Fuji MCCBs – Selection Guide			
Breaker Type	Handle Type	Price	Description
BW125	BW9F0CA-15A	<--->	Nema 12 flexible shaft handle for 125A frame. 59.06" (1.5m)cable
	BW9F0CA-20A	<--->	Nema 12 flexible shaft handle for 125A frame. 78.74" (2m) cable
BW250	BW9F0GA-15A	<--->	Nema 12 flexible shaft handle for 250A frame. 59.06" (1.5m)cable
	BW9F0GA-20A	<--->	Nema 12 flexible shaft handle for 250A frame. 78.74" (2m) cable
BW400*	BW9F0HA-15A	<--->	Nema 12 flexible shaft handle for 400A frame. 59.06" (1.5m)cable
	BW9F0HA-20A	<--->	Nema 12 flexible shaft handle for 400A frame. 78.74" (2m) cable
BW630* & BW800*	BW9F0JA-15A	<--->	Nema 12 flexible shaft handle for 630A or 800A frame. 59.06" (1.5m)cable
	BW9F0JA-20A	<--->	Nema 12 flexible shaft handle for 630A or 800A frame. 78.74" (2m) cable

\*Terminal covers for line side and load side included with Flange Disconnects. 2/pk

Flex Handle Specifications				
<b>Operating instructions</b>	<ul style="list-style-type: none"> <li>Operating handle facing up, Breaker is in ON position.</li> <li>Operating handle facing down, Breaker is in OFF position or is reset.</li> <li>Panel door cannot be opened when in ON, OFF or Trip position. In order to open the door, the handle must be turned toward reset position.</li> <li>Release screw is standard. If you want to open a panel door in ON position, please turn the release screw using flat head screwdriver.</li> </ul>			
<b>Frame Size</b>	<b>125A frame</b>	<b>250A frame</b>	<b>400A frame</b>	<b>630A/800 frame</b>
<b>Mechanical Endurance (cycles)</b>	10,000	8,000	6,000	6,000
<b>Ambient Temperature</b>	14 to 140F (- 10 to 40°C)			
<b>Relative Humidity</b>	less than 95% RH			
<b>Protection</b>	NEMA Type12 IP54 (IEC60529)			
<b>Conforming Standards</b>	NFPA 79(2007), ANSI(Lockout), OSHA(1910.147, Lockout/tagout), UL489(cUL)			
<b>Environment</b>	No excessive dust, smoke, corrosive gases, flammable gases, steam or salt.			

# Fuji Molded Case Circuit Breakers – Field-mountable Accessories

## Dimensions

Units: mm [inches]

### BW9F0HA

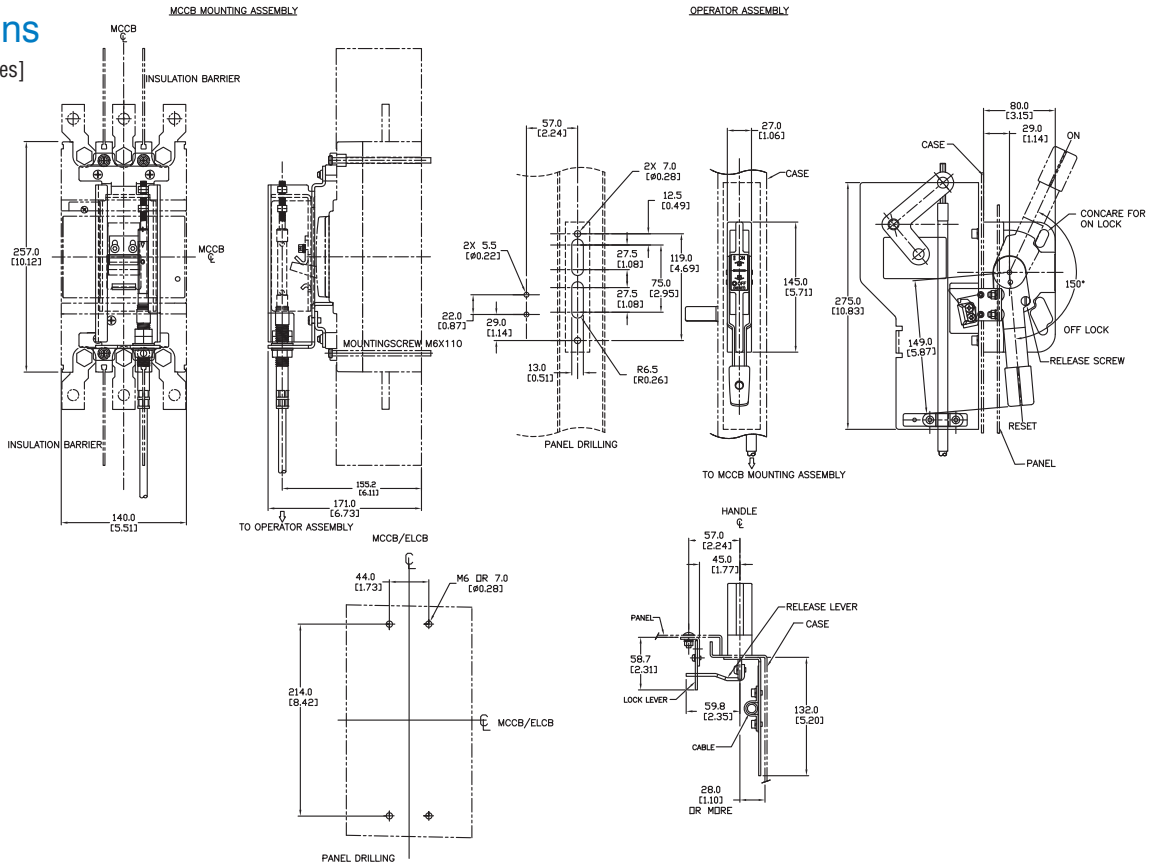

### BW9F0JA

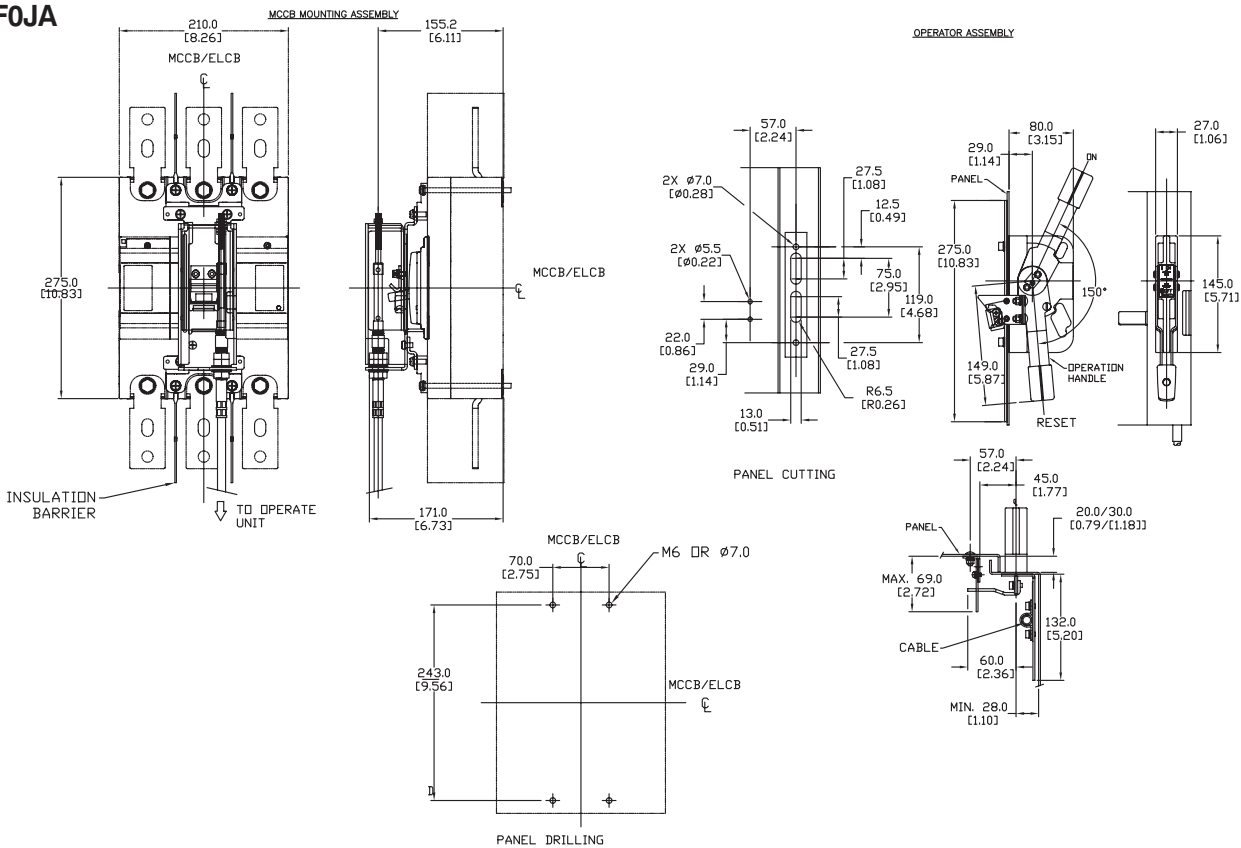

# Fuji Molded Case Circuit Breakers – Accessories



BW9W1SHA shown

## Auxiliary Contacts

The auxiliary contacts are accessory contacts for the indication of circuit breaker opened or tripped.

Auxiliary Contacts for Fuji MCCBs – Selection Guide			
Breaker Type	Part Number	Price	Description
BW125 BW250	BW9W1SGO	<--->	Auxiliary switch for for 125A and 250A frame. Mounting left and right side
		<--->	
BW400 BW630 BW800	BW9W1SHA	<--->	Auxiliary switch for for 400A , 630A and 800A frame. Mounting left side ONLY
		<--->	

Ratings of Auxiliary Switches								
Standard Type								
Breaker Type	Rated Thermal Current (A)	Make/Break Current (A)						Minimum Load Current
		AC			DC			
		Voltage (V)	Res. Load	Ind. Load	Voltage (V)	Res. Load	Ind. Load	
BW125, BW250, BW400 BW630, BW800	5	24	5	5	24	4	3	5V DC 160 mA
		48	5	5	48	2.5	1	30V DC 30 mA
		125	5	3	125	0.4	0.4	
		250	3	2	250	0.2	0.2	

### Operation of auxiliary switches

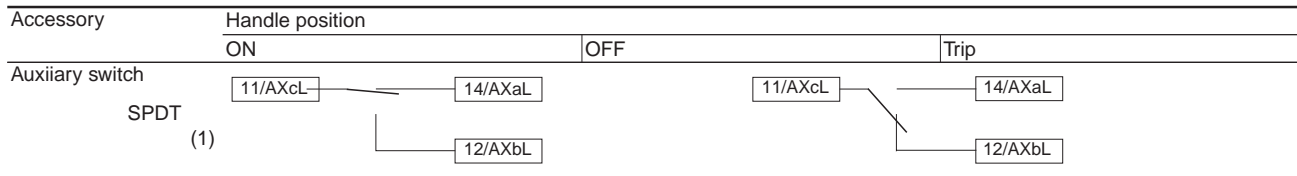

## Shunt Trips

Shunt Trip is for remote tripping (opening) of circuit breaker.



BW9FRG0 shown

Shunt Trips for Fuji MCCBs – Selection Guide		
Part Number	Price	Description
BW9FRG0	<--->	Field installable 24 VAC/VDC shunt trip for BW125 and BW250 series MCCB. Left and right side mounting. Lead wires 20AWG, 19.69" long.
BW9FHA-R	<--->	Field installable 24/48 VAC/VDC shunt trip for BW400, BW630 and BW800 series MCCB. Left side mounting only. Lead wires 20AWG, 19.69" long.
BW9FAG0	<--->	Field installable 100/120 VAC, 100-110 VDC shunt trip for BW125 and BW250 series MCCB. Left and right side mounting. Lead wires 20AWG, 19.69" long.
BW9FHA-A	<--->	Field installable 100/240 VAC, 100-220 VDC shunt trip for BW400, BW630 and BW800 series MCCB. Left side mounting only. Lead wires 20AWG, 19.69" long.

Ratings of Shunt Trips						
Breaker Type	AC		DC		Time Rating of Coil	Operating Time (ms)
	Voltage (V)	VA	Voltage (V)	W		
BW125, BW250	24	50	24	50	Continuous (with 1 N.O. contact to prevent coil burnout)	13-21
	100-120	50	100-110	50		
BW400, BW630, BW800	24-48	2	24-48	2	Continuous	8-20
	100-240	3	100-220	3		

Note: Allowable operating voltage AC voltage: 85% to 110% of coil rated voltage DC voltage: 75% to 125% of coil rated voltage

# Fuji Molded Case Circuit Breakers – Accessories



## Undervoltage Releases

Undervoltage Release will trip the circuit breaker when the connected voltage drops to less than 70% of undervoltage release voltage rating. It will allow the circuit breaker to close (ON) when voltage is approximately 85% of rated voltage.

Undervoltage Releases for Fuji MCCBs – Selection Guide				
Breaker Type	Part Number	Price	Description	
BW125, BW250	BW9RGAR	<-->	Undervoltage Release 24V DC (Left side ONLY)	
BW125, BW250	BW9RGAT	<-->	Undervoltage Release 110 to 130 VAC VAC/VDC (Left side ONLY)	
BW400, BW630, BW800	BW9RHA-R	<-->	Undervoltage Release 24 VAC/VDC (Left side ONLY)	
BW400, BW630, BW800	BW9RHA-1	<-->	Undervoltage Release 120 to 130 VAC 125 VDC (Left side ONLY)	



BW9RGAR shown

Breaker Type	AC		DC	
	Voltage (V)	VA	Voltage (V)	W
BW125*1 BW250*1	–	–	24	5
	110 - 130	5	–	–
BW400*2 BW630*2 BW800*2	24	2	24	2
	120 - 130	3	125	3

Note: Allowable operating voltage: AC voltage: 85% to 110% of coil rated voltage  
DC voltage: 75% to 125% of coil rated voltage.

\*1 Reset-allowed type: When the breaker handle is in the OFF or RESET state, tripping does not occur, even if the undervoltage trip coil is not energized.  
Turning ON with the undervoltage trip coil not energized causes normal tripping.

\*2 Reset-prohibited type: When the undervoltage trip coil is not energized, reset operation cannot reset the tripped breaker to the OFF state.



BW9SL0GA-3 shown

## Replacement Lugs

Replacement Lug Kits for Fuji MCCBs – Selection Guide		
Part Number	Price	Description
BW9SLOCA-3	<-->	Replacement lug kit for BW125 series MCCB. 75°C. Cu only Package of 3
BW9SLOGA-3	<-->	Replacement lug kit for BW250 series up to 175A MCCB. 75°C. Cu only Package of 3
BW9SL1GA-3	<-->	Replacement lug kit for BW250 MCCB series 200A to 250A. 75°C. Cu only Package of 3

# Fuji Molded Case Circuit Breakers – Accessories



## Terminal Covers

Terminal covers act as guards to shield the operator from touching live terminations. They fit either the line or load side.



**BW9BTHA-L3W** shown

Terminal Covers for Fuji MCCBs – Selection Guide						
Breaker Series	Part Number	Price	Description	Dimensions inch (mm)		
				A	B	C
BW400	<b>BW9BTHA-L3W</b>	<--->	Gray-white Long type terminal cover for Fuji MCCBs. For line side and load side. 2/pk	6.772 (172)	4.331 (110)	3.858 (98)
BW630, BW800	<b>BW9BTJA-L3W</b>	<--->	Gray-white Long type terminal cover for Fuji MCCBs. For line side and load side. 2/pk	8.268 (210)	6.102 (155)	3.858 (98)

*Note: Gray-white short type terminal covers are provided with breakers as standard for 125 and 250 Amp frames.*

Dimensions of Terminal Covers: inch (mm)

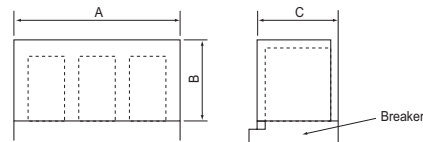

## Lockout Attachment

Lockout Attachments for Fuji MCCBs – Selection Guide			
Breaker Series	Part Number	Price	Description
BW125 BW250	<b>BW9Q1CA</b>	<--->	Use to lock out BW125 and BW 250 series MCCBs. Lock not included.
BW400, BW630, BW800	<b>BW9QNHA</b>	<--->	Use to lock out BW400, BW600 and BW800 MCCBs. Lock not included.



**BW9Q1CA** shown