

DURAPULSE AC Drives – Introduction



DURApulse Drives																
Motor Rating	Hp	1	2	3	5	7.5	10	15	20	25	30	40	50	60	75	100
	kW	.75	1.5	2.2	3.7	5.5	7.5	11	15	18.5	22	30	37	45	55	75
Single/Three-Phase Input 230V	✓	✓	✓													
Three-Phase 230V Class				✓	✓	✓	✓	✓	✓	✓	✓	✓	✓			
Three-Phase 460V Class	✓	✓	✓	✓	✓	✓	✓	✓	✓	✓	✓	✓	✓	✓	✓	✓

Overview

The *DURAPULSE* series of AC drives offers all of the features of our GS2 series of drives including dynamic braking, PID, removable keypad and RS-485 Modbus communication. The *DURAPULSE* AC drive also offers sensorless vector control with the option of encoder feedback for enhanced speed control. The standard **smart** keypad (or Human Interface Module) is designed with defaults for the North American customer and allows you to configure the drive, set the speed, start and stop the drive, and monitor critical parameters for your application. In addition, this keypad has internal memory that allows **four** complete programs to be stored and transferred to any *DURAPULSE* drive. The *DURAPULSE* series offers three analog inputs, eleven digital inputs, and one SPDT relay output.

Features

- Simple Volts/Hertz control
- Sensorless vector control with autotune
- Sensorless vector control with optional encoder feedback card, for better speed control
- Sinusoidal pulse width modulation (PWM)
- Variable carrier frequency, depending on model
- IGBT technology
- Starting torque: 125% @ 0.5 Hz/150% @ 1Hz
- 150% rated current for one minute
- Electronic overload protection
- Stall prevention
- Adjustable accel and decel ramps with linear and S-curve settings
- Automatic torque and slip compensation
- Internal dynamic braking circuit for models under 20 hp; optional braking units available for models 20 hp and above
- DC braking
- Five skip frequencies
- Trip history
- Programmable jog speed
- Integral PID control
- Removable **smart** keypad with parameter upload/download
- Keypad with memory to store up to four programs of any *DURAPULSE* drive
- Eleven programmable digital inputs
- Three programmable analog inputs
- Three digital and one SPDT relay programmable outputs
- One programmable analog output

- One digital frequency output
- RS-485 Modbus communications
- Ethernet communication optional
- Two-year warranty
- UL/cUL/CE listed

Accessories

- AC line reactors
- EMI filters
- RF filters
- Braking resistors
- Braking units (for models 20 hp and above)
- Fuse kits and replacement fuses
- Replacement cooling fans
- Remote panel adapter
- Replacement keypad
- Keypad cables in 1, 3, and 5-meter lengths
- Ethernet interface
- Four and eight-port RS-485 multi-drop termination boards
- KEP *Direct* I/O or OPC Server
- GSoft drive configuration software
- GS3-FB – feedback card
- GS-485HD15-CBL – *ZIP*Link RS485 communication cable for connection to the DL06 and D2-260 15-pin ports
- USB-485M – USB to RS-485 PC adapter (see “Communications Products” chapter for detailed information)

Detailed descriptions and specifications for GS accessories are available in the “GS/DURAPULSE Accessories” section.

DURAPULSE part numbering system

GS3 - 2 020

Applicable Motor Capacity

1P0: 1HP	2P0: 2HP
3P0: 3HP	5P0: 5HP
7P5: 7.5HP	010: 10HP
015: 15HP	020: 20HP
025: 25HP	030: 30HP
040: 40HP	050: 50HP
060: 60HP*	075: 75HP*
100: 100HP*	

* 60, 75 and 100HP models available in GS3-4xxx only

Input Voltage

2: 200-240VAC
4: 380-480VAC

Series Name

Typical Applications

- Conveyors
- Fans
- Pumps
- Compressors
- HVAC
- Material handling
- Mixing
- Shop tools
- Extruding
- Grinding



DURAPULSE AC Drives Specifications

Company Information

Systems Overview

Programmable Controllers

Field I/O

Software

C-more & other HMI

Drives

Soft Starters

Motors & Gearbox

Steppers/ Servos

Motor Controls

Proximity Sensors

Photo Sensors

Limit Switches

Encoders

Current Sensors

Pressure Sensors

Temperature Sensors

Pushbuttons/ Lights

Process

Relays/ Timers

Comm.

Terminal Blocks & Wiring

Power

Circuit Protection

Enclosures

Tools

Pneumatics

Safety

Appendix

Product Index

Part # Index

230V Class														
Model Name: GS3-xxx			21P0	22P0	23P0	25P0	27P5	2010	2015	2020	2025	2030	2040	2050
Price			<--->	<--->	<--->	<--->	<--->	<--->	<--->	<--->	<--->	<--->	<--->	<--->
Output Rating	Maximum Motor Output	HP	1.0	2.0	3.0	5.0	7.5	10	15	20	25	30	40	50
		kW	.75	1.5	2.2	3.7	5.5	7.5	11	15	18.5	22	30	37
	Rated Output Current (A)		5	7	11	17	25	33	49	65	75	90	120	145
	Maximum Output Voltage		Three-phase 200 to 240V (proportional to input voltage)											
Rated Frequency		0.1 to 400 Hz												
* Input Rating	Rated Voltage/Frequency		Single/Three-phase				Three-phase							
			200/208/220/230/240 VAC, 50/60Hz											
Rated Input Current (A)		11.9 / 5.7	15.3 / 7.6	22 / 15.5	20.6	26	34	50	60	75	90	110	142	
Voltage/Frequency Tolerance		Voltage: ± 10% Frequency: ± 5%												
Watt Loss @ 100% I (W)		60	82	130	194	301	380	660	750	920	1300	1340	1430	
Weight (lb [kg])		4.5 [2.034]	4.5 [2.034]	9.4 [4.24]	9.4 [4.24]	13.3 [6.031]	13.3 [6.031]	14.3 [6.487]	26.5 [12]	26.5 [12]	26.5 [12]	77.2 [35]	77.2 [35]	

* All 3-phase power sources must be symmetrical.
Do not connect any DURApulse drives to grounded, center-tapped delta transformers (which are typically used for lighting circuits).

460V Class – Three-Phase																	
Model Name: GS3-xxx		41P0	42P0	43P0	45P0	47P5	4010	4015	4020	4025	4030	4040	4050	4060	4075	4100	
Price		<--->	<--->	<--->	<--->	<--->	<--->	<--->	<--->	<--->	<--->	<--->	<--->	<--->	<--->	<--->	
Output Rating	Maximum Motor Output	HP	1	2	3	5	7.5	10	15	20	25	30	40	50	60	75	100
		kW	.75	1.5	2.2	3.7	5.5	7.5	11	15	18.5	22	30	37	45	55	75
	Rated Output Current (A)		2.7	4.2	5.5	8.5	13	18	24	32	38	45	60	73	91	110	150
	Maximum Output Voltage		Three-phase 380 to 480V (proportional to input voltage)														
Rated Frequency		0.1 to 400 Hz															
* Input Rating	Rated Voltage/Frequency		Three-phase, 380/400/415/440/460/480VAC, 50/60Hz														
	Rated Input Current (A)		3.2	4.3	5.9	11.2	14	19	25	32	39	49	60	63	90	130	160
Voltage/Frequency Tolerance		Voltage: ± 10% Frequency: ± 5%															
Watt Loss @ 100% I (W)		70	102	132	176	250	345	445	620	788	1290	1420	1680	2020	2910	3840	
Weight (lb [kg])		3.9 [1.759]	4.4 [1.994]	4.1 [1.857]	9.4 [4.24]	13.2 [6.002]	13.5 [6.106]	14.4 [6.525]	26.5 [12]	26.5 [12]	26.5 [12]	77.2 [35]	77.2 [35]	77.2 [35]	116.8 [53]	116.8 [53]	

* All 3-phase power sources must be symmetrical.
Do not connect any DURApulse drives to grounded, center-tapped delta transformers (which are typically used for lighting circuits).

DURAPULSE AC Drives General Specifications

General Specifications			
Control Characteristics			
Control System	Pulse Width Modulation, Carrier frequency adjustable from 1k - 15kHz depending on the model. This system determines the control methods of the AC drive. 00: V/Hz open loop control 01: V/Hz closed loop control 02: Sensorless Vector 03: Sensorless Vector with external feedback		
Rated Output Frequency	0.1 to 400.0 Hz		
Output Frequency Resolution	0.1 Hz		
Overload Capacity	150% of rated current for 1 minute		
Torque Characteristics	Includes auto-torque boost, auto-slip compensation, starting torque 125% @ 0.5 Hz / 150% @ 1.0 Hz		
Braking Torque	20% without braking resistor, 125% with optional braking resistor (braking circuit built-in only for units under 20 hp)		
DC Braking	Operation frequency 60-0 Hz, 0 - 100% rated current, Start time 0.0 - 5.0 seconds, Stop time 0.0 - 25.0 seconds		
Acceleration/Deceleration Time	0.1 to 600 seconds (linear or non-linear acceleration/deceleration), second acceleration/deceleration available		
Voltage/Frequency Pattern	Settings available for Constant Torque - low & high starting torque, Variable Torque - low & high starting torque, and user configured		
Stall Prevention Level	20 to 200% of rated current		
Operation Specification			
Inputs	Frequency Setting	Keypad	Setting by <UP> or <DOWN> buttons
		External Signal	Potentiometer - 3 to 5 k Ω , 0 to 10 VDC (input impedance 10 k Ω), -10 to +10 VDC, 4 to 20 mA (input impedance 250 Ω), 0 to 20 mA; Multi-Speed Inputs 1 to 4, RS-232C/RS-485 communication interface
	Operation Setting	Keypad	Setting by <RUN>, <STOP>, <JOG>, <FWD>, <REV> buttons
		External Signal	Forward/Stop, Reverse/Stop (run/stop, fwd/rev), 3-wire control, Serial Communication RS-232C & RS-485 (Modbus RTU)
	Input Terminals	Digital Sink/Source Selectable	11 user-programmable: FWD/STOP, REV/STOP, RUN/STOP, REV/FWD, RUN momentary (N.O.), STOP momentary (N.C.), External Fault (N.O./N.C.), External Reset, Multi-Speed Bit (1-4), Manual Keyboard Control, Jog, External Base Block (N.O./N.C.), Second Accel/Decel Time, Speed Hold, Increase Speed, Decrease Speed, Reset Speed to Zero, PID Disable (N.O.), PID Disable (N.C.), Input Disable
		Analog	3 user-configurable, 0 to 10V (input impedance 10 k Ω), 0 to 20 mA, 4 to 20 mA (input impedance 250 Ω), 10 bit resolution -10V to +10V, 10 bit resolution
Outputs	Output Terminals	Digital 3 transistors 1 relay	4 user-programmable: Inverter Running, Inverter Fault, At Speed, Zero Speed, Above Desired Frequency, Below Desired Frequency, At Maximum Speed, Over Torque Detected, Above Desired Current, Below Desired Current, PID Deviation Alarm, Heatsink Overheat Warning (OH), Soft Braking Signal, Above desired Frequency 2, Below desired Frequency 2, Encoder Loss
		Digital Square Wave	One digital square wave output representing drive frequency
		Analog	1 user-programmable, 0 to 10V, 8 bit resolution frequency, current, process variable PV
Operating Functions		Automatic voltage regulation, voltage/frequency characteristics selection, non-linear acceleration/deceleration, upper and lower frequency limiters, 15-stage speed operation, adjustable carrier frequency (1 to 15 kHz), PID control, 5 skip frequencies, analog gain & bias adjustment, jog, electronic thermal relay, automatic torque boost, trip history, software protection	
Protective Functions		Electronic Thermal, Overload Relay, Auto Restart after Fault, Momentary Power Loss, Reverse Operation Inhibit, Auto Voltage Regulation, Over-Voltage Stall Prevention, Auto Adjustable Accel/Decel, Over-Torque Detection Mode, Over-Torque Detection Level, Over-Torque Detection Time, Over-Current Stall Prevention during Acceleration, Over-Current Stall Prevention during Operation	
Operator Interface	Operator Devices		9-key, 2 line x 16 character LCD display, 5 status LEDs
	Programming		Parameter values for setup and review, fault codes
	Status Display		Output Frequency, Motor Speed, Scaled Frequency, Output Current, Motor Load, Output Voltage, DC Bus Voltage, PID Setpoint, PID Feedback, Frequency Setpoint
	Key Functions		RUN, STOP/RESET, FWD/REV, PROGRAM, DISPLAY, <UP>, <DOWN>, ENTER
Environment	Enclosure Rating		Protected Chassis, IP20
	Ambient Temperature		-10°C to 40°C (14°F to 104°F)
	Storage Temperature		-20°C to 60°C (-4°F to 140°F) – during short term transportation period
	Ambient Humidity		20 to 90% RH (non-condensing)
	Vibration		9.8 m/s ² (1G) less than 10 Hz, 5.9 m/s ² (0.6G) 10 to 60 Hz
	Installation Location		Altitude 1000m or lower above sea level, keep from corrosive gas, liquid and dust
Options		Noise filter, input AC reactor, output AC reactor, cable for remote operator, programming software, dynamic braking resistor, dynamic braking unit; RF filter; remote panel adapter; Ethernet interface; four and eight port RS-485 multi-drop termination boards, replacement keypads, fuse kits and replacement fuses	

DURAPULSE Drives Specifications – Installation

Understanding the installation requirements for your DURAPULSE AC drive will help to ensure that it operates within its environmental and electrical limits.

Note: Never use only this catalog for installation instructions or operation of equipment; refer to the user manual, GS3-M.

Watt-loss Chart	
GS3 Drive Model	At full load
GS3-21P0	60
GS3-22P0	82
GS3-23P0	130
GS3-25P0	194
GS3-27P5	301
GS3-2010	380
GS3-2015	660
GS3-2020	750
GS3-2025	920
GS3-2030	1300
GS3-2040	1340
GS3-2050	1430
GS3-41P0	70
GS3-42P0	102
GS3-43P0	132
GS3-45P0	176
GS3-47P5	250
GS3-4010	345
GS3-4015	445
GS3-4020	620
GS3-4025	788
GS3-4030	1290
GS3-4040	1420
GS3-4050	1680
GS3-4060	2020
GS3-4075	2910
GS3-4100	3840

Environmental Specifications	
Protective Structure ¹	IP20
Ambient Operating Temperature ²	-10 to 40°C (14°F to 104°F) f
Storage Temperature ³	-20 to 60°C (-4°F to 140°F)
Humidity	To 90% (no condensation)
Vibration ⁴	9.8 m/s ² (1g), less than 10 Hz 5.9 m/s ² (0.6g), 10 to 60 Hz
Location	Altitude 1,000 m or less, indoors (no corrosive gases, liquids or dust)
<p>1: Protective structure is based upon EN60529</p> <p>2: The ambient temperature must be in the range of -10° to 40°C. If the range will be up to 50°C, you will need to set the carrier frequency to 2.1 kHz or less and derate the output current to 80% or less.</p> <p>3: The storage temperature refers to the short-term temperature during transport.</p> <p>4: Conforms to the test method specified in JIS C0911 (1984)</p>	

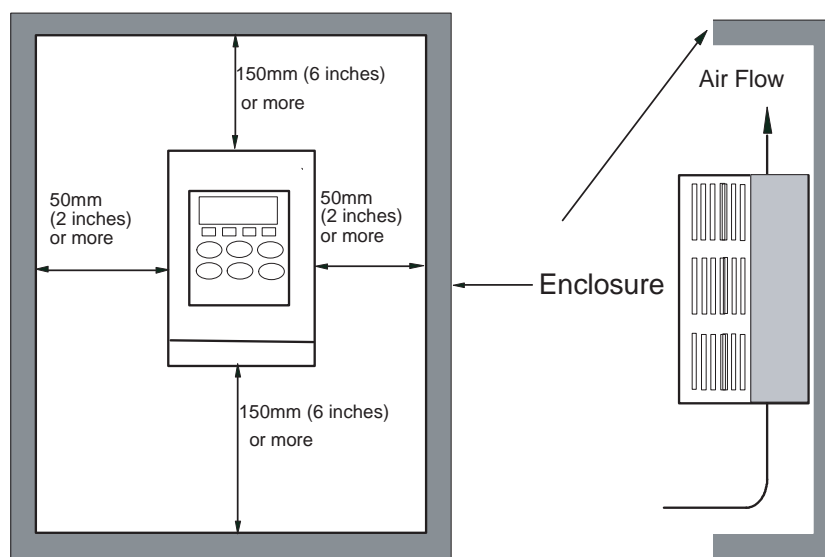

Minimum Clearances and Air Flow



Warning: AC drives generate a large amount of heat which may damage the AC drive. Auxiliary cooling methods are typically required in order not to exceed maximum ambient temperatures.



Warning: Maximum ambient temperatures must not exceed 50°C (122°F), or 40°C (104°F) for models 7.5 hp (5.5 kW) and higher!

DURAPULSE AC Drives Specifications — Terminals

Main Circuit Terminals	
Terminal	Description
L1, L2, L3	Input Power
T1, T2, T3	AC Drive Output
B1, B2	Braking Resistor Connection (Under 20HP)
+2, - (negative)	External Dynamic Brake Unit (20HP & Over)
	Ground



GS3-4030 shown

Control Circuit Terminals		
Terminal Symbol	Description	Remarks
+24V	DC Voltage Source	(+24V, 20mA), used only for AC drive digital inputs wired for source mode operation
DI1	Digital Input 1	Input Voltage: Internally Supplied (see Warning below) Sink Mode: Low active, VinL Min = 0V, VinL Max = 15V, Iin Min = 2.1mA, Iin Max = 7.0mA Source Mode: High active, VinH Min = 8.5V, VinH Max = 24V, Iin Min = 2.1mA, Iin Max = 7.0mA Input response: 12 - 15 msec Also see "Basic Wiring Diagram" on the next pages.
DI2	Digital Input 2	
DI3	Digital Input 3	
DI4	Digital Input 4	
DI5	Digital Input 5	
DI6	Digital Input 6	
DI7	Digital Input 7	
DI8	Digital Input 8	
DI9	Digital Input 9	
DI10	Digital Input 10	
DI11	Digital Input 11	
DCM	Digital Common	
+10V	Internal Power Supply	+10VDC (10mA maximum load)
AI1	Analog Input	0 to +10 V input only
AI2	Analog Input	0 to 20mA / 4 to 20mA input
AI3	Analog Input	-10 to +10 V input only
ACM	Analog Common	
R10	Relay Output 1 Normally Open	Resistor Load: 240VAC - 5A (N.O.) / 3A (N.C.) 24VDC - 5A (N.O.) / 3A (N.C.) Inductive Load: 240VAC - 1.5A (N.O.) / 0.5A (N.C.) 24VDC - 1.5A (N.O.) / 0.5A (N.C.) See P 3.01 to P 3.03
R1C	Relay Output 1 Normally Closed	
R1	Relay Output 1 Common	
DO1	Photocoupled digital output	Maximum 48VDC, 50mA
DO2	Photocoupled digital output	
DO3	Photocoupled digital output	
DOC	Digital Output Common	
AO	Analog Output	0 to +10 V 2mA Output
FO	Digital Frequency Output	Square wave pulse train output



WARNING: Do NOT connect external voltage sources to the digital inputs. Permanent damage may result.



NOTE: USE TWISTED-SHIELDED, TWISTED-PAIR OR SHIELDED-LEAD WIRES FOR THE CONTROL SIGNAL WIRING. IT IS RECOMMENDED TO RUN ALL SIGNAL WIRING IN A SEPARATE STEEL CONDUIT. THE SHIELD WIRE SHOULD ONLY BE CONNECTED AT THE AC DRIVE. DO NOT CONNECT SHIELD WIRE ON BOTH ENDS.

DURAPULSE AC Drives – Basic Wiring Diagram

Power Wiring Diagram - drives under 20 hp

Note: Users **MUST** connect wiring according to the circuit diagram shown below. (Refer to user manual GS3-M for additional specific wiring information.)

Note: Refer to the following pages for explanations and information regarding feedback cards, line reactors, braking resistors, EMI and RF filters, and fuses: 13-48, 13-50, 13-69, 13-74, 13-80, 13-81.

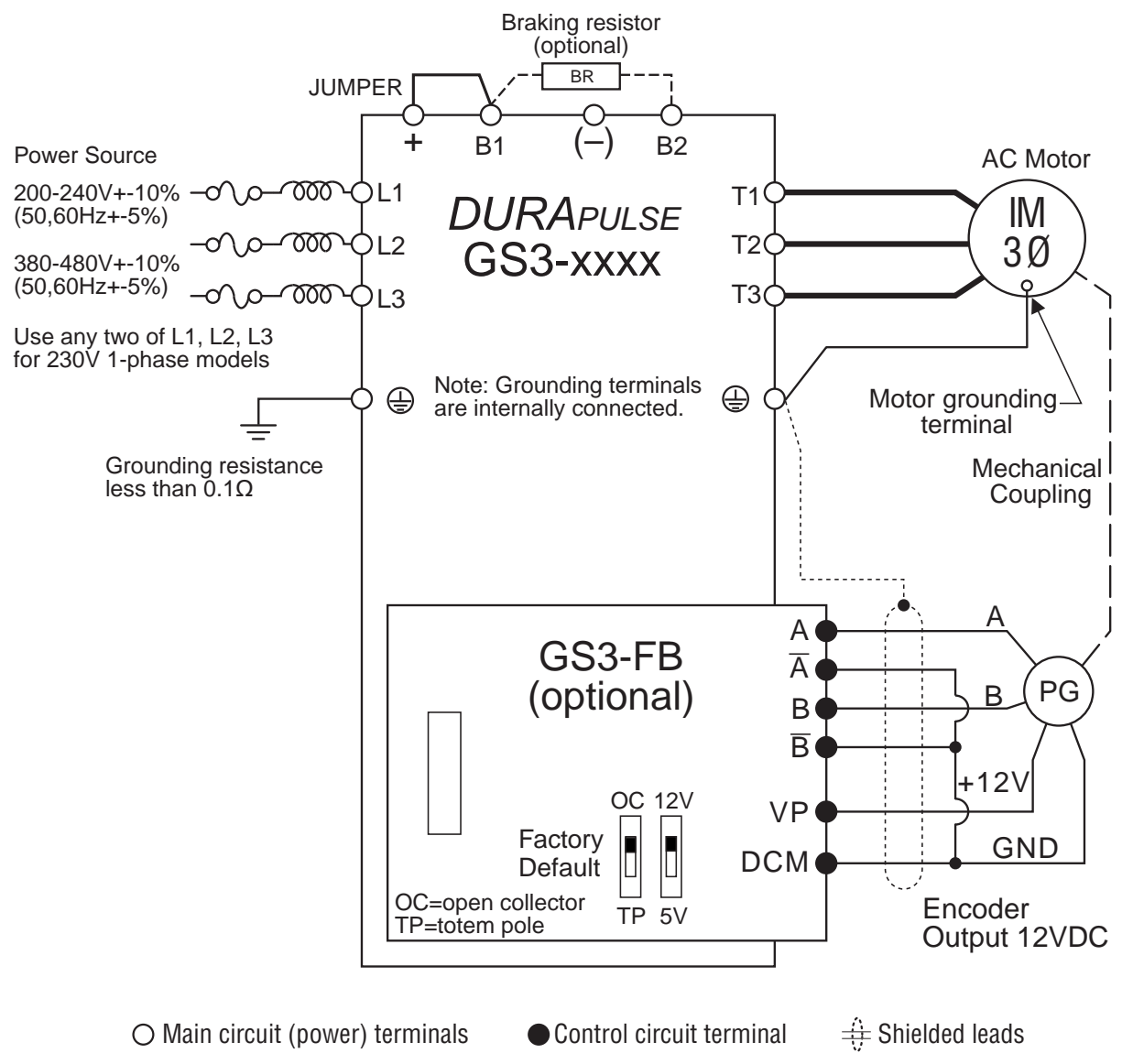

WARNING: Do not plug a modem or telephone into the GS3/DURAPULSE RJ-12 Serial Comm Port, or permanent damage may result. Terminals 2 and 5 should not be used as a power source for your communication connection.

DURAPULSE AC Drives – Basic Wiring Diagram

Power Wiring Diagram – 20 to 30 hp (230 VAC) & 20 to 60 hp (460 VAC)

Note: Users **MUST** connect wiring according to the circuit diagram shown below. (Refer to user manual GS3-M for additional specific wiring information.)

Note: Refer to the following pages for explanations and information regarding feedback cards, line reactors, braking units and resistors, EMI and RF filters, and fuses: 13-48, 13-50, 13-67, 13-69, 13-74, 13-80, 13-81.

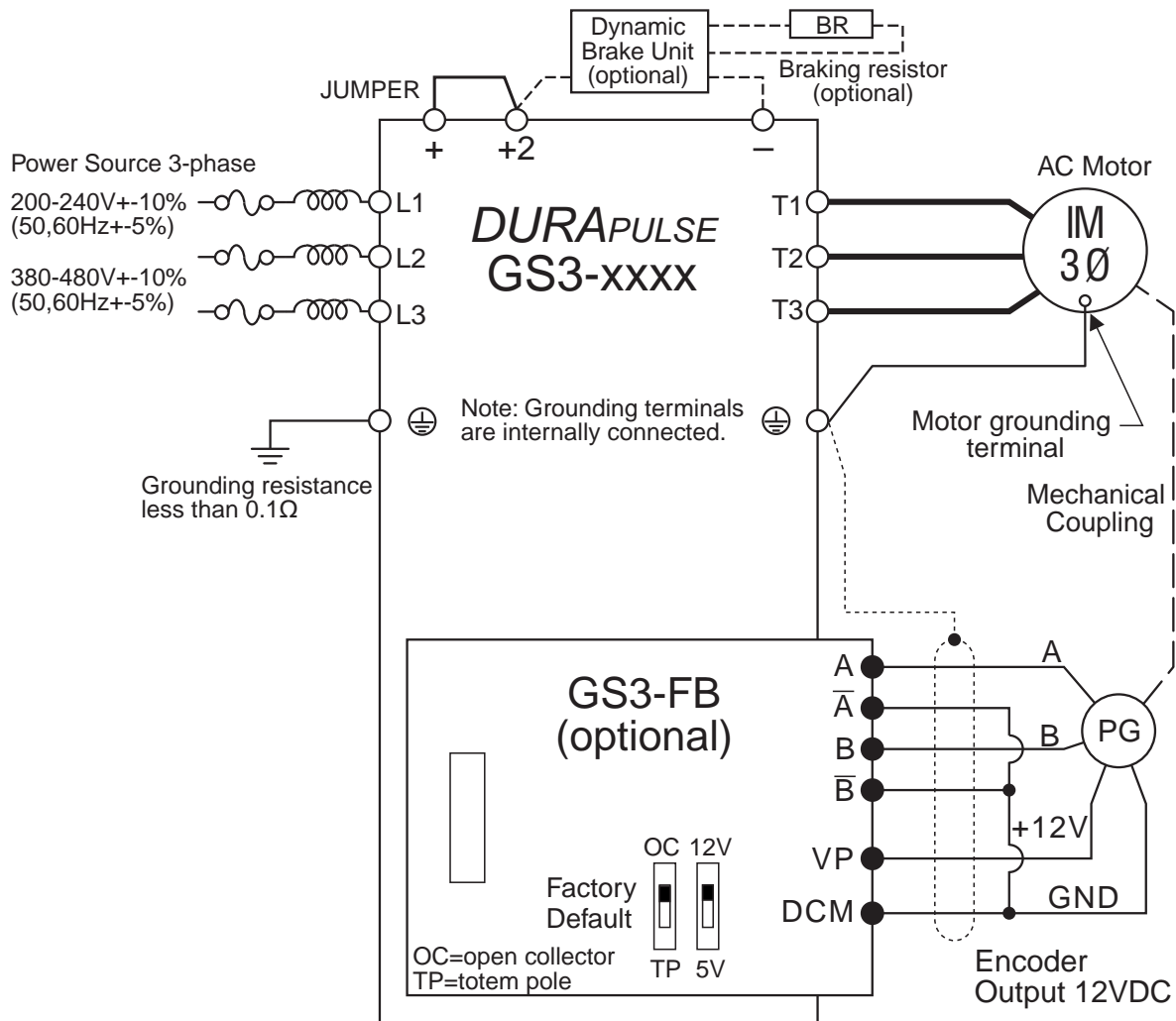

○ Main circuit (power) terminals ● Control circuit terminal ⊕ Shielded leads



WARNING: Do not plug a modem or telephone into the GS3/DURAPULSE RJ-12 Serial Comm Port, or permanent damage may result. Terminals 2 and 5 should not be used as a power source for your communication connection.

DURAPULSE AC Drives – Basic Wiring Diagram

Power Wiring Diagram - 40 to 50 hp (230 VAC) & 75 to 100 hp (460 VAC)

Note: Users **MUST** connect wiring according to the circuit diagram shown below. (Refer to user manual GS3-M for additional specific wiring information.)

Note: Refer to the following pages for explanations and information regarding feedback cards, line reactors, braking units and resistors, EMI and RF filters, and fuses: 13-48, 13-50, 13-67, 13-69, 13-74, 13-80, 13-81.

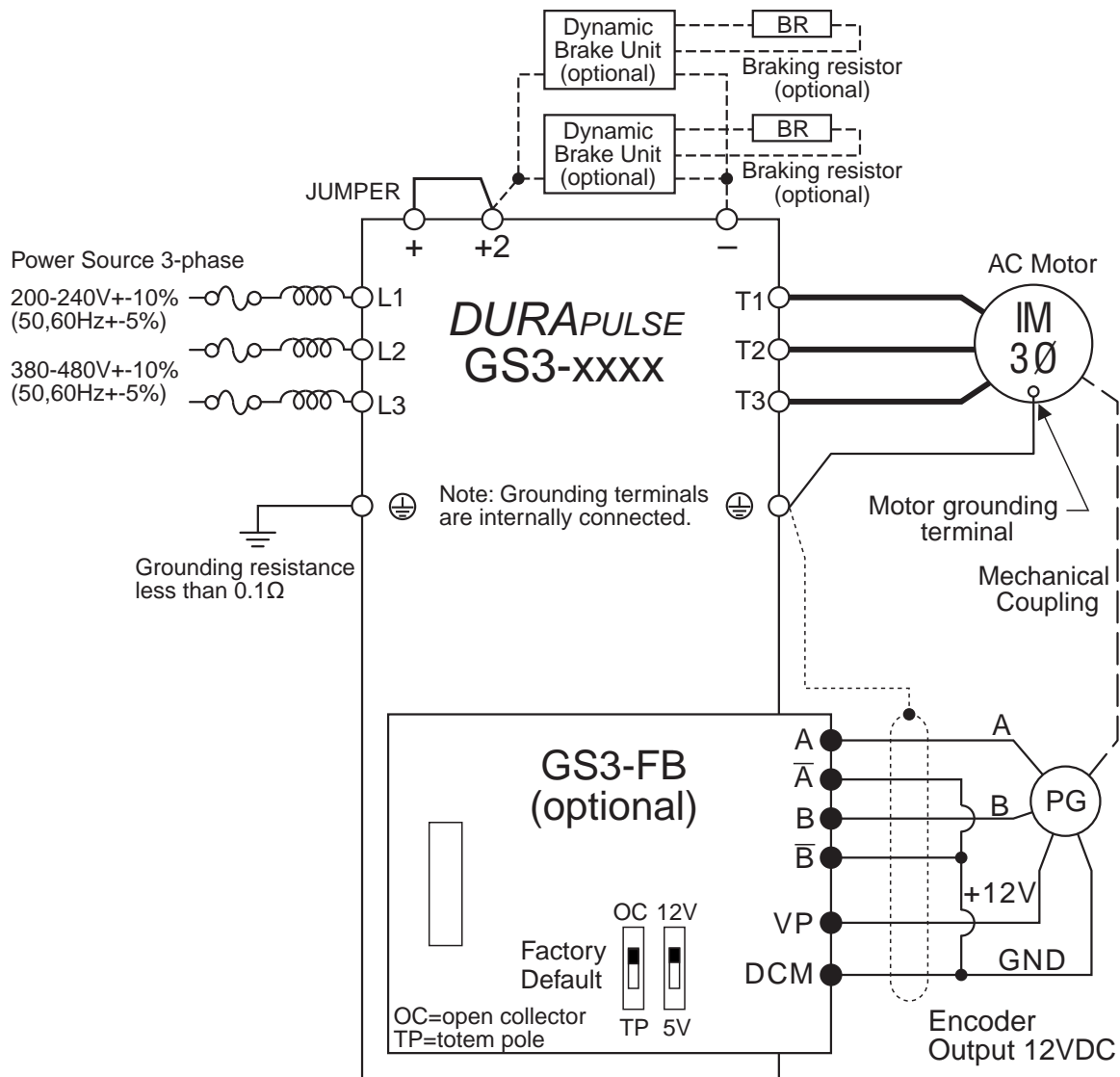

○ Main circuit (power) terminals ● Control circuit terminal ⊕ Shielded leads



WARNING: Do not plug a modem or telephone into the GS3/DURAPULSE RJ-12 Serial Comm Port, or permanent damage may result. Terminals 2 and 5 should not be used as a power source for your communication connection.

DURAPULSE AC Drives – Control Wiring Diagram – DI Connection to Sinking Outputs

Control Wiring Diagram - Digital Input Connections to Sinking Output Devices



NOTE: USERS MUST CONNECT WIRING ACCORDING TO THE CIRCUIT DIAGRAM SHOWN BELOW.

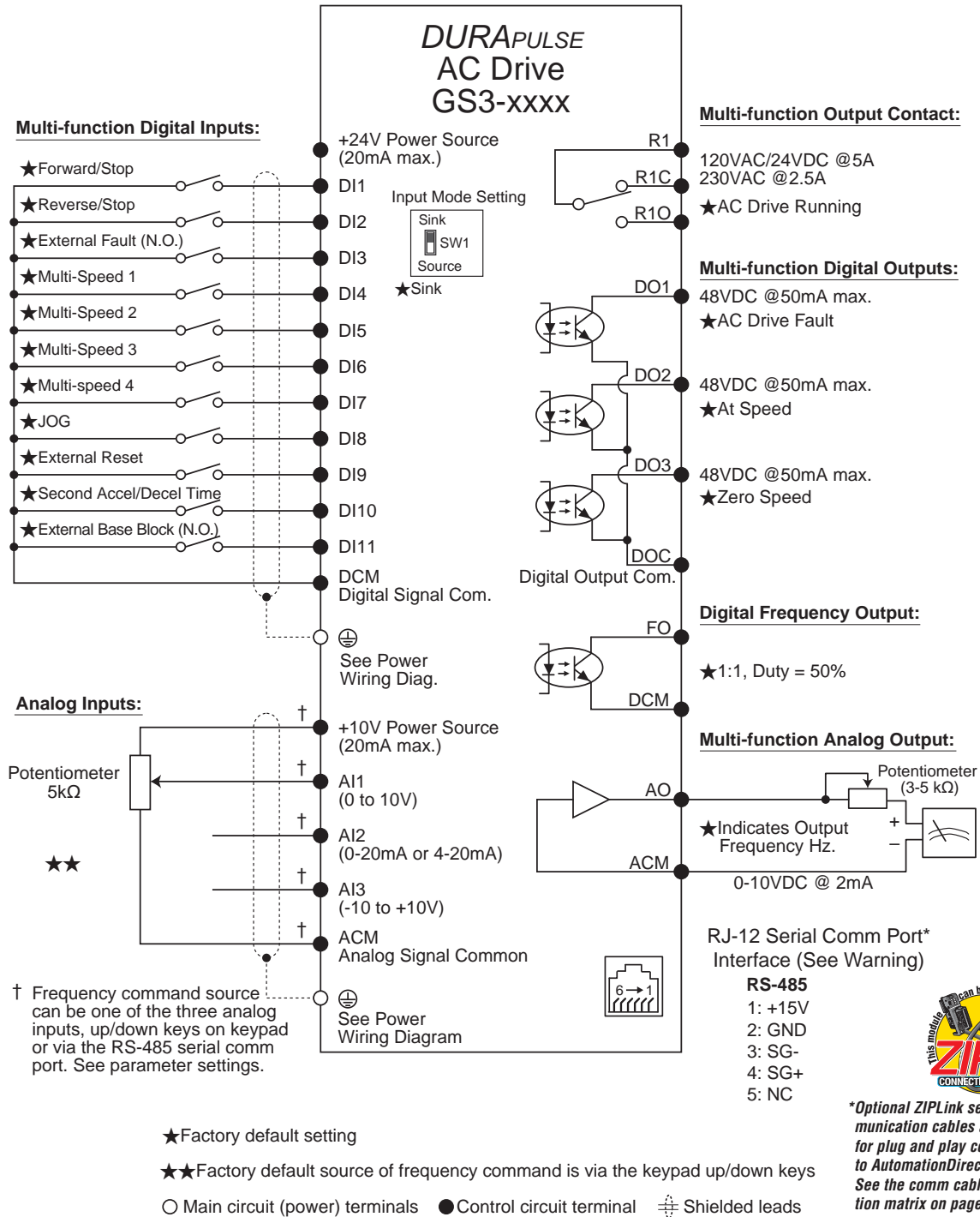

**Optional ZIPLink serial communication cables available for plug and play connectivity to AutomationDirect PLCs. See the comm cable selection matrix on page 13-93.*



WARNING: Do not plug a modem or telephone into the DURAPULSE RJ-12 Serial Comm Port, or permanent damage may result.

DURAPULSE AC Drives – Control Wiring Diagram – DI Connections to Sourcing Outputs

Control Wiring Diagram - Digital Input Connections to Sourcing Output Devices



NOTE: USERS MUST CONNECT WIRING ACCORDING TO THE CIRCUIT DIAGRAM SHOWN BELOW.

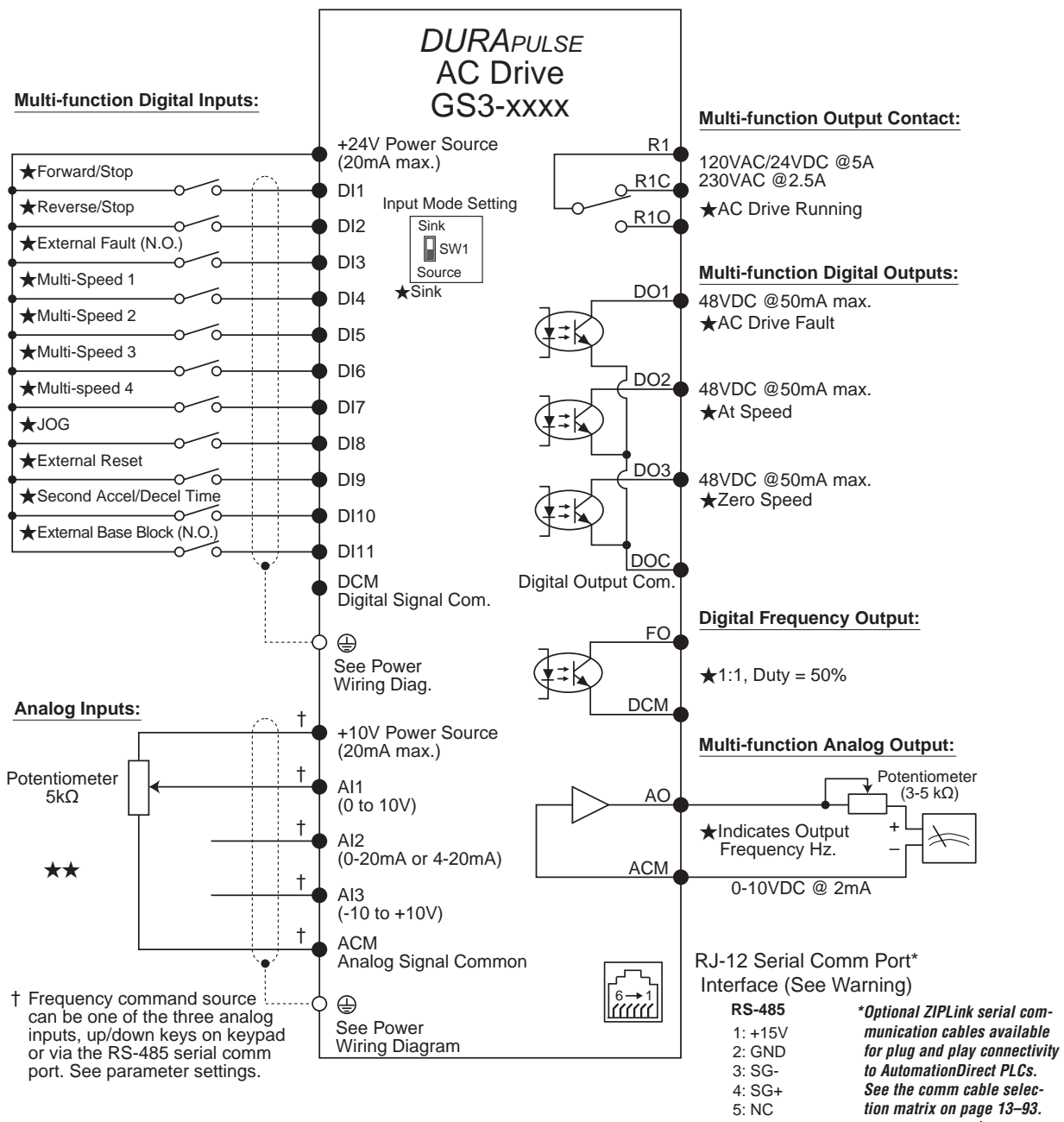

WARNING: Do not plug a modem or telephone into the DURAPULSE RJ-12 Serial Comm Port, or permanent damage may result.

DURAPULSE AC Drives — Dimensions

GS3-21P0, GS3-22P0, GS3-41P0, GS3-42P0

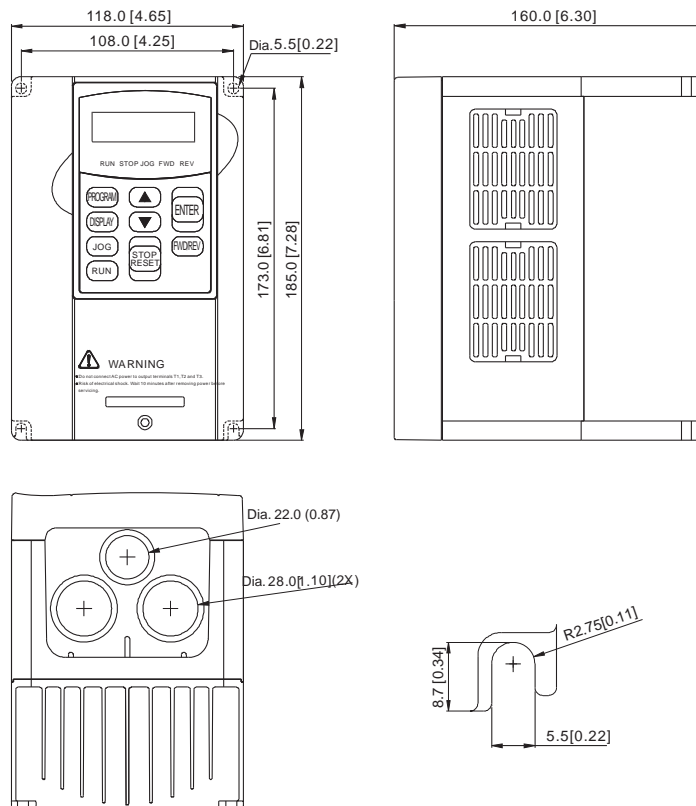

GS3-23P0, GS3-25P0, GS3-45P0

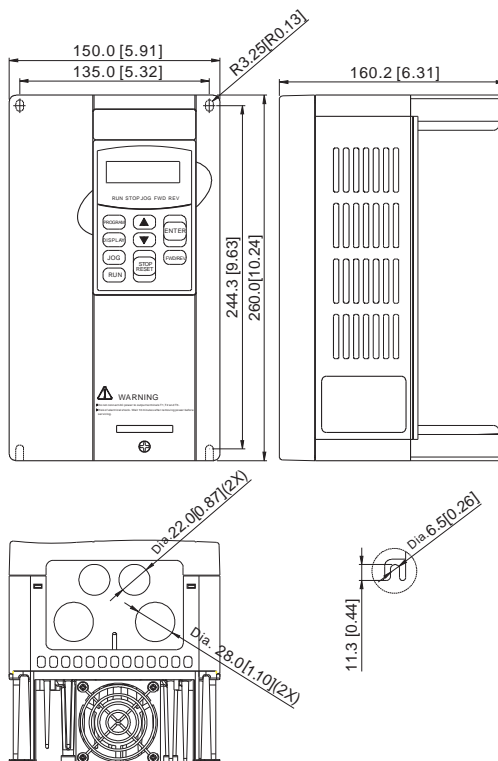

unit: mm(in)

DURAPULSE AC Drives — Dimensions

GS3-27P5, GS3-2010, GS3-2015, GS3-47P5, GS3-4010, GS3-4015

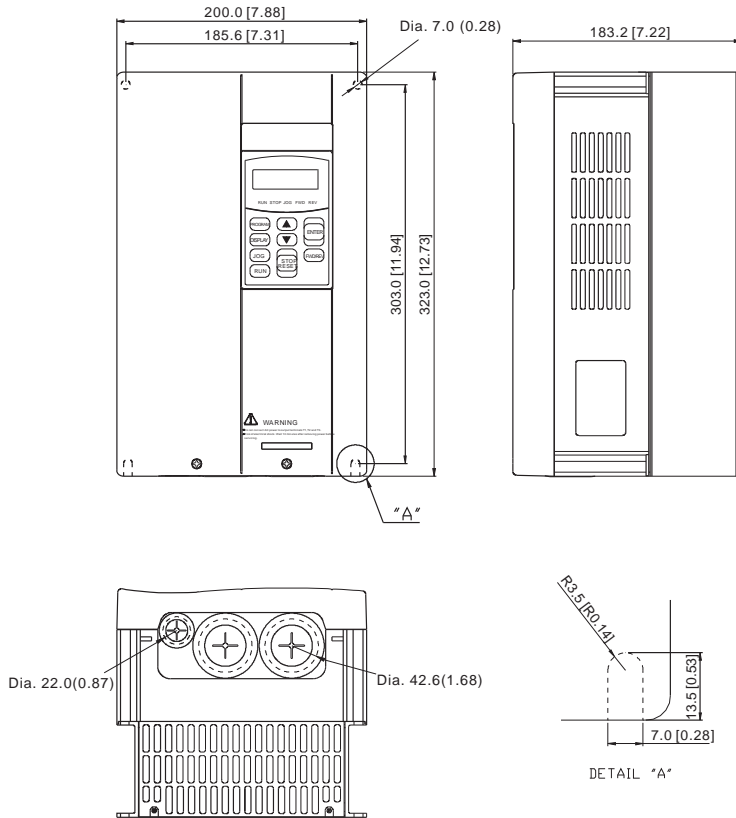

GS3-2020, GS3-2025, GS3-2030, GS3-4020, GS3-4025, GS3-4030

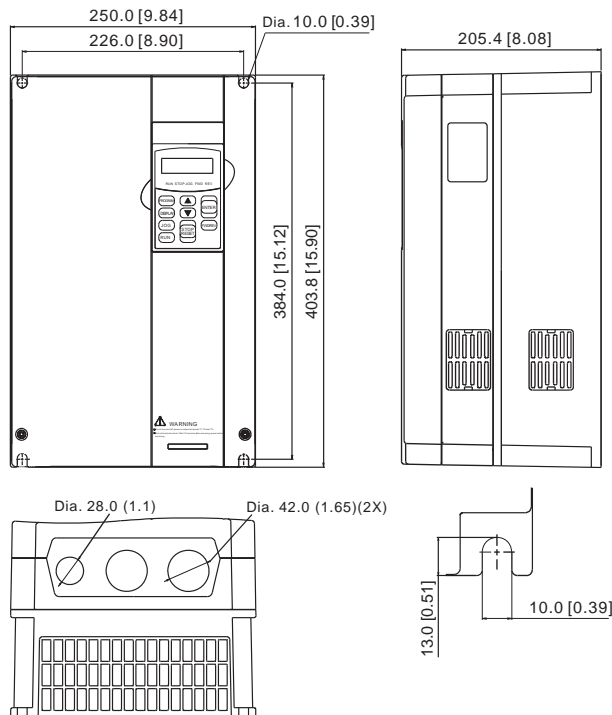

unit: mm(in)

DURAPULSE AC Drives — Dimensions

GS3-2040, GS3-2050, GS3-4040, GS3-4050, GS3-4060

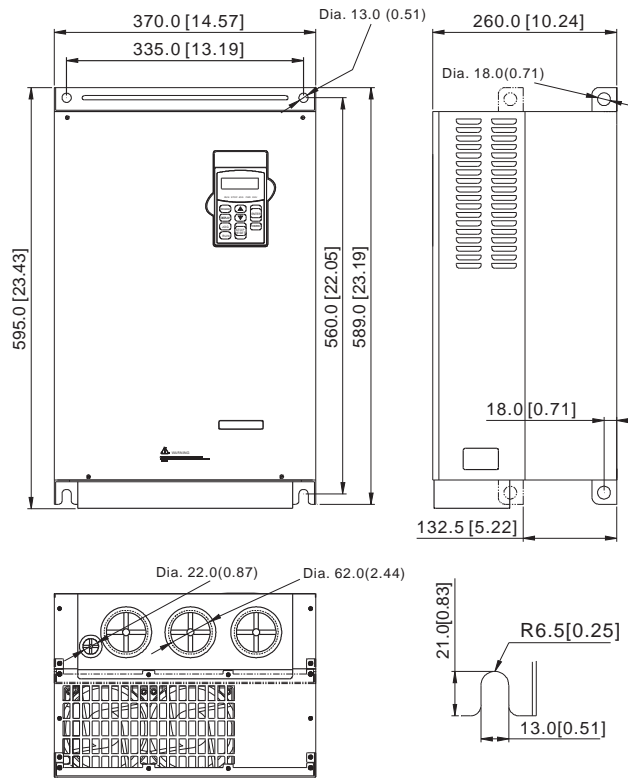

GS3-43P0

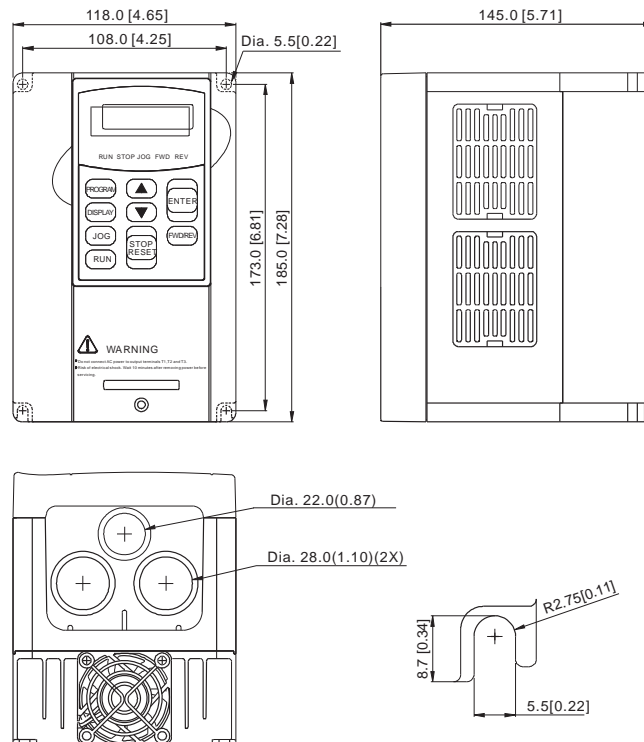

unit: mm(in)

DURAPULSE AC Drives — Dimensions

GS3-4075, GS3-4100

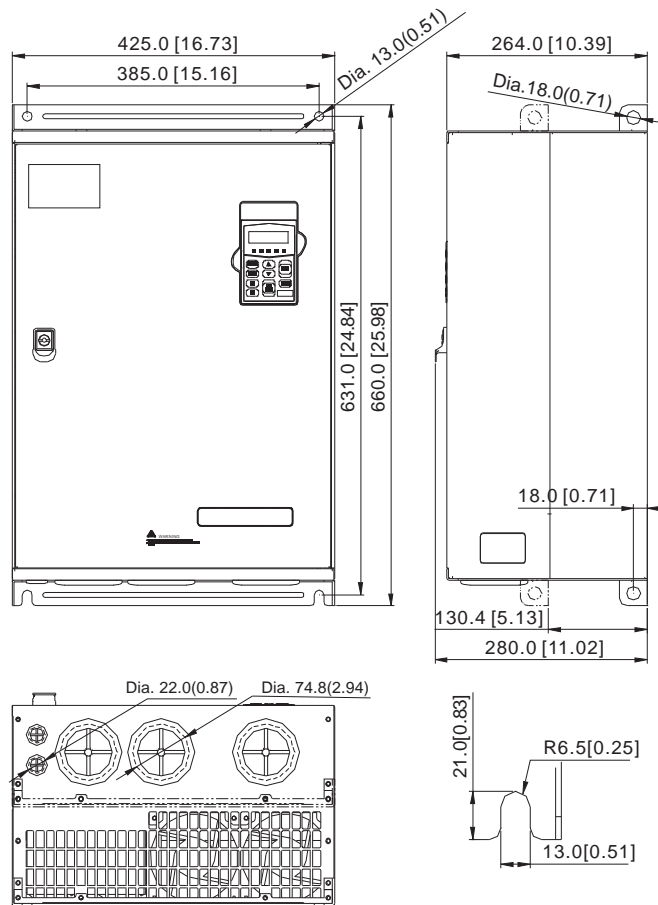

unit: mm(in)

GS/DURAPULSE Accessories – Overview

Accessories – Part numbering system

Note: With the exception of the EMI filters, RF filters, and LR series line reactors, each accessory part number begins with GS, followed by the AC Drive rating, and then the relevant accessory code. Following the accessory code, you will find a description code when applicable. The diagram at right shows the accessory part numbering system.

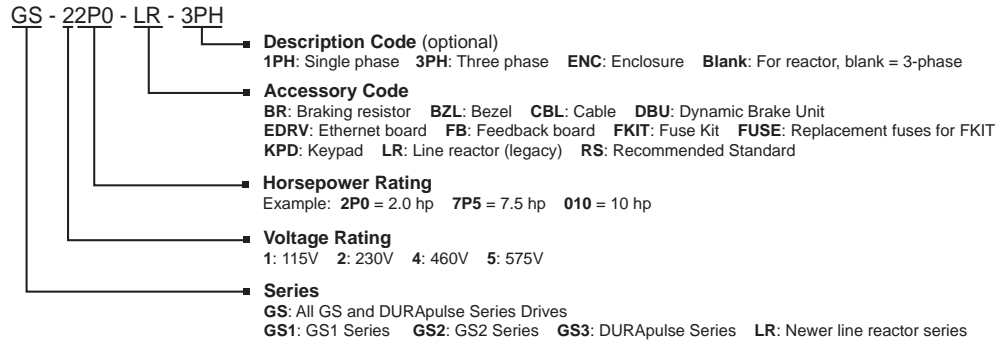

Under 20hp

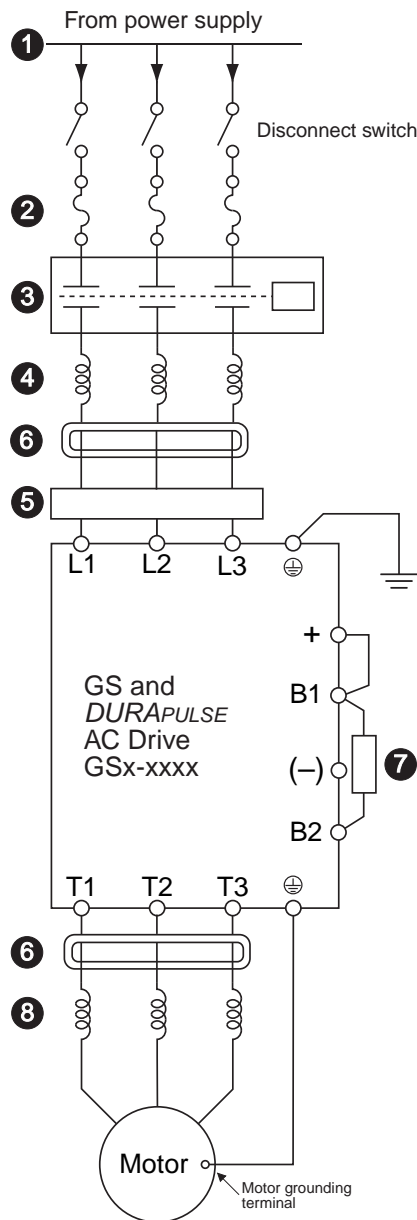

1 Power Supply

Please follow the specific power supply requirements shown in Chapter 1 and the Warning section of the applicable GS or *DURAPULSE* AC Drives User Manual.

2 Fuses (Refer to page 13–81.)

Input fuses protect the AC drive from excessive input current due to line surges, short circuits, and ground faults. They are recommended for all installations and may be required for UL-listed installations. (*AutomationDirect fuses are not available for GS1 drives.*)

3 Contactor (Optional) (Refer to the Motor Controls section.)

Do not use a contactor or disconnect switch for run/stop control of the AC drive and motor. This will reduce the operating life cycle of the AC drive. Cycling a power circuit switching device while the AC drive is in run mode should be done only in emergency situations.

4 Input Line Reactor (Optional) (Refer to page 13–50.)

Input line reactors protect the AC drive from transient overvoltage conditions, typically caused by utility capacitor switching. The input line reactor also reduces the harmonics associated with AC drives. Input line reactors are recommended for all installations.

5 EMI filter (Optional) (Refer to page 13–74.)

Input EMI filters reduce electromagnetic interference or noise on the input side of the AC drive. They are required for CE compliance and recommended for installations prone to or sensitive to electromagnetic interference. (*Separate EMI filters are not necessary for GS1 drives.*)

6 RF filter (Optional) (Refer to page 13–80.)

RF filters reduce the radio frequency interference or noise on the input or output side of the inverter.

7 Braking Resistor (Optional) (Refer to page 13–69.)

Dynamic braking allows the AC drive to produce additional braking (stopping) torque. AC drives can typically produce between 15% & 20% braking torque without the addition of any external components. The addition of optional braking may be required for applications that require rapid deceleration or high inertia loads. (*Braking resistors are not available for GS1 drives.*)

8 Output Line Reactor (Optional) (Refer to page 13–50.)

Output line reactors protect the motor insulation against AC drive short circuits and IGBT reflective wave damage, and also “smooth” the motor current waveform, allowing the motor to run cooler. They are **recommended for operating “non-inverter-duty” motors** and when the length of wiring between the AC drive and motor exceeds 75 feet.

GS/DURAPULSE Accessories – Overview

20hp & Over (DURAPULSE only)

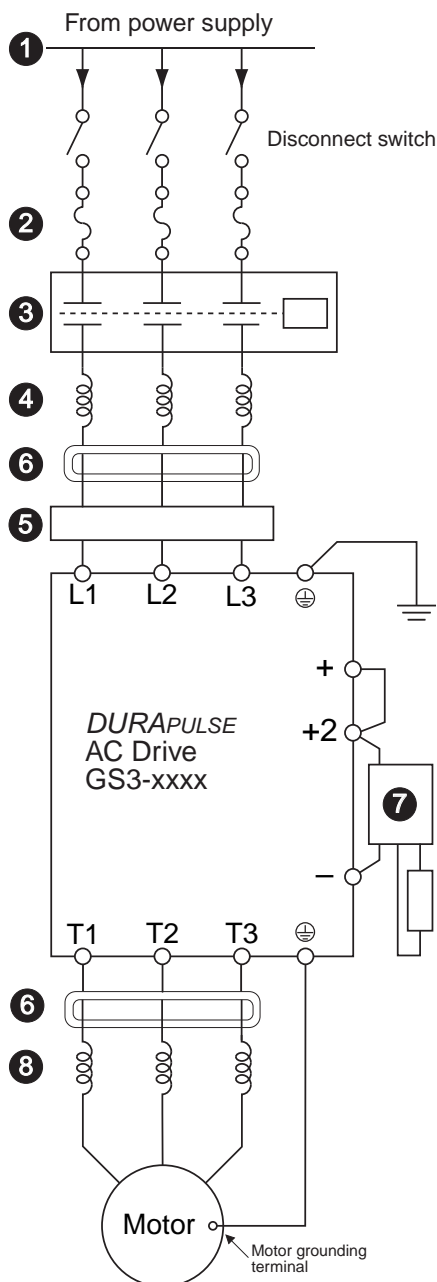

1 Power Supply

Please follow the specific power supply requirements shown in Chapter 1 of the *DURAPULSE AC Drives User Manual*.

2 Fuses (Refer to page 13–81.)

Input fuses protect the AC drive from excessive input current due to line surges, short circuits, and ground faults. They are recommended for all installations and may be required for UL-listed installations.

3 Contactor (Optional) (Refer to the Motor Controls section.)

Do not use a contactor or disconnect switch for run/stop control of the AC drive and motor. This will reduce the operating life cycle of the AC drive. Cycling a power circuit switching device while the AC drive is in run mode should be done only in emergency situations.

4 Input Line Reactor (Optional) (Refer to page 13–50.)

Input line reactors protect the AC drive from transient overvoltage conditions, typically caused by utility capacitor switching. The input line reactor also reduces the harmonics associated with AC drives. Input line reactors are recommended for all installations.

5 EMI filter (Optional) (Refer to page 13–74.)

Input EMI filters reduce electromagnetic interference or noise on the input side of the AC drive. They are required for CE compliance and recommended for installations prone to or sensitive to electromagnetic interference.

6 RF filter (Optional) (Refer to page 13–80.)

RF filters reduce the radio frequency interference or noise on the input or output side of the inverter.

7 Braking Unit & Braking Resistor (Optional) (pg 13–67)

Dynamic braking allows the AC drive to produce additional braking (stopping) torque. AC drives can typically produce between 15% & 20% braking torque without the addition of any external components. The addition of optional braking may be required for applications that require rapid deceleration or high inertia loads.

8 Output Line Reactor (Optional) (Refer to page 13–50.)

Output line reactors protect the motor insulation against AC drive short circuits and IGBT reflective wave damage, and also “smooth” the motor current waveform, allowing the motor to run cooler. They are **recommended for operating “non-inverter-duty” motors** and when the **length of wiring between the AC drive and motor exceeds 75 feet**.

GS/DURAPULSE Accessories – Feedback Card

Feedback Card for DURAPULSE AC Drives		
Part Number	Price	Drive Model
GS3-FB	<--->	GS3-xxxx
The GS3-FB feedback card is for use only with DURApulse AC drives.		

Description

The GS3-FB card is used to add another layer of precision control to the already precise control algorithm utilized in the DURAPULSE drive series. This added control is activated by selecting control modes V/Hz closed loop control or sensorless vector with external feedback. The feedback mechanism uses pulses generated by an external encoder or pulse generator. Unlike other feedback types, the GS3-FB accommodates the four most common encoder signal types: output voltage, open collector, line driver, and complimentary.



Closed Loop Diagram

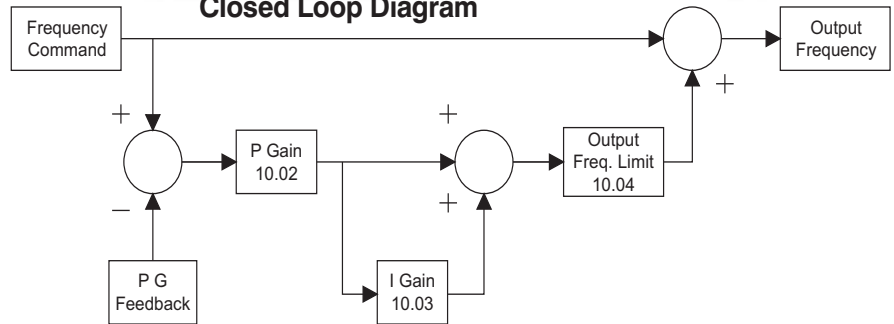

Types of Encoders		SW1 and SW2 switches	
		5V	12V
Output Voltage			
Open collector			
Line driver			
Complimentary			

GS/DURAPULSE Accessories – Feedback Card

Wiring Diagrams

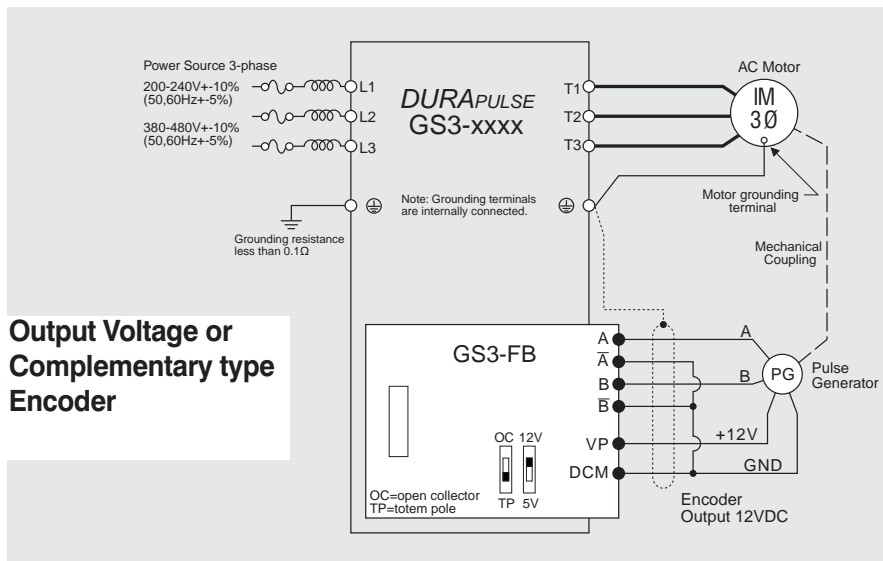
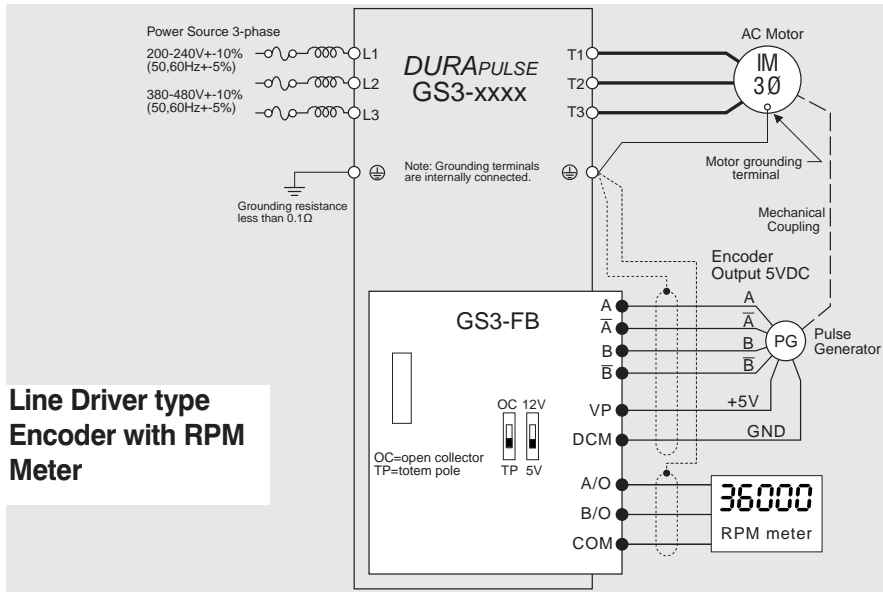
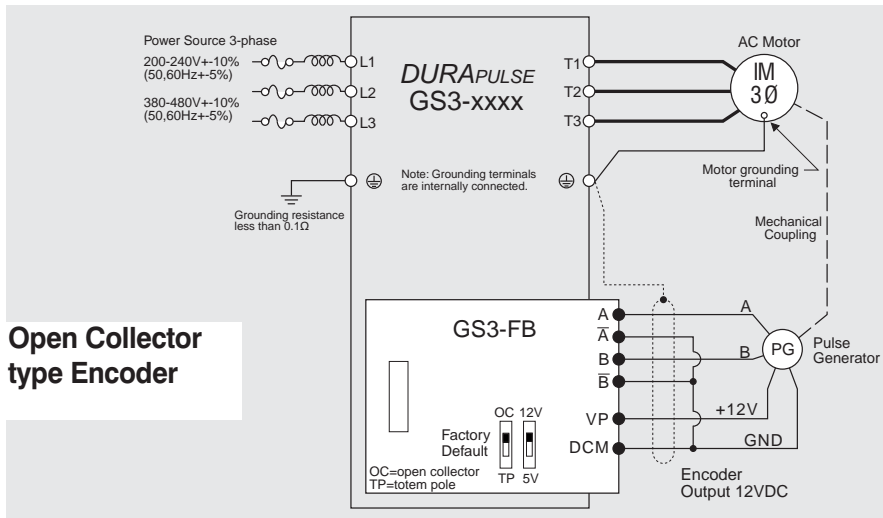

Terminal Symbols	Description
VP	Power source of GS3-FB (SW1 can be switched to 12V or 5V) Output Voltage: (+12VDC ±5% 200mA) or (+5VDC ±2% 400mA)
DCM	Power source (VP) and input signal (A, B) common
A, NOT A, B, NOT B	Input signal from Encoder. Input type is selected by SW2; Maximum 500KP/sec
A/O, B/O	GS3-FB output signal for use with RPM Meter. (Open Collector) Maximum DC24V 100mA
COM	GS3-FB output signal (A/O, B/O) common

Control Terminals Block Designations

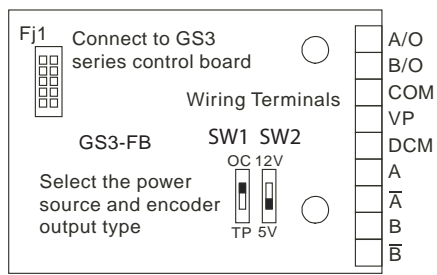

- Company Information
- Systems Overview
- Programmable Controllers
- Field I/O
- Software
- C-more & other HMI
- Drives**
- Soft Starters
- Motors & Gearbox
- Steppers/Servos
- Motor Controls
- Proximity Sensors
- Photo Sensors
- Limit Switches
- Encoders
- Current Sensors
- Pressure Sensors
- Temperature Sensors
- Pushbuttons/Lights
- Process
- Relays/Timers
- Comm.
- Terminal Blocks & Wiring
- Power
- Circuit Protection
- Enclosures
- Tools
- Pneumatics
- Safety
- Appendix
- Product Index
- Part # Index

Wiring Solutions using the ZIPLink Wiring System

ZIPLinks eliminate the normally tedious process of wiring between devices by utilizing prewired cables and DIN rail mount connector modules. It's as simple as plugging in a cable connector at either end or terminating wires at only one end. Prewired cables keep installation clean and efficient, using half the space at a fraction of the cost of standard terminal blocks. There are several wiring solutions available when using the ZIPLink System ranging from

PLC I/O-to-ZIPLink Connector Modules that are ready for field termination, options for connecting to third party devices, GS, DuraPulse and SureServo Drives, and specialty relay, transorb and communications modules. Pre-printed I/O-specific adhesive label strips for quick marking of ZIPLink modules are provided with ZIPLink cables. See the following solutions to help determine the best ZIPLink system for your application.

Solution 1: DirectLOGIC, CLICK and Productivity3000 I/O Modules to ZIPLink Connector Modules

When looking for quick and easy I/O-to-field termination, a ZIPLink connector module used in conjunction with a prewired ZIPLink cable, consisting of an I/O terminal block at one end and a multi-pin connector at the other end, is the best solution.



Using the PLC I/O Modules to ZIPLink Connector Modules selector tables located in this section,

1. Locate your I/O module/PLC.
2. Select a ZIPLink Module.
3. Select a corresponding ZIPLink Cable.

Solution 2: DirectLOGIC, CLICK and Productivity3000 I/O Modules to 3rd Party Devices

When wanting to connect I/O to another device within close proximity of the I/O modules, no extra terminal blocks are necessary when using the ZIPLink Pigtail Cables. ZIPLink Pigtail Cables are prewired to an I/O terminal block with color-coded pigtail with soldered-tip wires on the other end.



Using the I/O Modules to 3rd Party Devices selector tables located in this section,

1. Locate your PLC I/O module.
2. Select a ZIPLink Pigtail Cable that is compatible with your 3rd party device.

Solution 3: GS Series and DuraPulse Drives Communication Cables

Need to communicate via Modbus RTU to a drive or a network of drives?

ZIPLink cables are available in a wide range of configurations for connecting to PLCs and SureServo, SureStep, Stellar Soft Starter and AC drives. Add a ZIPLink communications module to quickly and easily set up a multi-device network.

Using the Drives Communication selector tables located in this section,

1. Locate your Drive and type of communications.
2. Select a ZIPLink cable and other associated hardware.



Drives

Soft Starters

Motors & Gearbox

Steppers/ Servos

Motor Controls

Proximity Sensors

Photo Sensors

Limit Switches

Encoders

Current Sensors

Pressure Sensors

Temperature Sensors

Pushbuttons/ Lights

Process

Relays/ Timers

Comm.

Terminal Blocks & Wiring

Power

Circuit Protection

Enclosures

Tools

Pneumatics

Safety

Appendix

Product Index

Part # Index

Solution 4: Serial Communications Cables

ZIPLink offers communications cables for use with *Direct*LOGIC, CLICK, and Productivity3000 CPUs, that can also be used with other communications devices. Connections include a 6-pin RJ12 or 9-pin, 15-pin and 25-pin D-sub connectors which can be used in conjunction with the RJ12 or D-Sub Feedthrough modules.

Using the **Serial Communications Cables** selector table located in this section,

1. Locate your connector type
2. Select a cable.



Solution 5: Specialty ZIPLink Modules

For additional application solutions, ZIPLink modules are available in a variety of configurations including stand-alone relays, 24VDC and 120VAC transorb modules, D-sub and RJ12 feedthrough modules, communication port adapter and distribution modules, and SureServo 50-pin I/O interface connection.

Using the **ZIPLink Specialty Modules** selector table located in this section,

1. Locate the type of application.
2. Select a ZIPLink module.



Solution 6: ZIPLink Connector Modules to 3rd Party Devices

If you need a way to connect your device to terminal blocks without all that wiring time, then our pigtail cables with color-coded soldered-tip wires are a good solution. Used in conjunction with any compatible ZIPLink Connector Modules, a pigtail cable keeps wiring clean and easy and reduces troubleshooting time.

Using the **Universal Connector Modules and Pigtail Cables** table located in this section,

1. Select module type.
2. Select the number of pins.
3. Select cable.



Drive / Motor Controller (GS/DuraPulse/SureServo/SureStep/Stellar) ZIPLink Selector								
Drive / Motor Controller		Communications			ZIPLink Cable			
Controller	Comm Port Type	Network/Protocol	Connects to	Comm Port Type	Cable (2 meter length)	Cable Connectors	Other Hardware Required	
GS1	RJ12	RS-485 Modbus RTU	DL06 PLCs	Port 2 (HD15)	GS-485HD15-CBL-2	RJ12 to HD15	—	
			D2-260 CPU				—	
			GS-EDRV100	RJ12	GS-EDRV-CBL-2	RJ12 to RJ12	—	
			ZL-CDM-RJ12Xxx*	RJ12	GS-485RJ12-CBL-2		—	
FA-ISOCOCON	5-pin Connector	GS-ISOCOCON-CBL-2	RJ12 to 5-pin plug	—				
GS2	RJ12	RS-232 Modbus RTU	CLICK PLCs	Port 2 (RJ12)	GS-RJ12-CBL-2	RJ12 to RJ12	—	
			DL05 PLCs				—	
			DL06 PLCs	Port 2 (HD15)			FA-15HD	
			D2-250-1 CPU					
			D2-260 CPU	Port 3 (25-pin)			FA-CABKIT	
			D4-450 CPU					
		P3-550 CPU	Port 2 (RJ12)	—				
		RS-485 Modbus RTU	DL06 PLCs	Port 2 (HD15)	GS-485HD15-CBL-2	RJ12 to HD15	—	
			D2-260 CPU				—	
			GS-EDRV100	RJ12	GS-EDRV-CBL-2	RJ12 to RJ12	—	
			ZL-CDM-RJ12Xxx*	RJ12	GS-485RJ12-CBL-2		—	
			FA-ISOCOCON	5-pin Connector	GS-ISOCOCON-CBL-2	RJ12 to 5-pin plug	—	
DuraPulse (GS3)	RJ12		RS-485 Modbus RTU	DL06 PLCs	Port 2 (HD15)	GS-485HD15-CBL-2	RJ12 to HD15	—
		D2-260 CPU		—				
		GS-EDRV100		RJ12	GS-EDRV-CBL-2	RJ12 to RJ12	—	
		ZL-CDM-RJ12Xxx*		RJ12	GS-485RJ12-CBL-2		—	
FA-ISOCOCON	5-pin Connector	GS-ISOCOCON-CBL-2	RJ12 to 5-pin plug	—				
SureServo	IEEE1394 (CN3)	RS-232 Modbus RTU	CLICK PLCs	Port 2 (RJ12)	SVC-232RJ12-CBL-2	6-pin IEEE to RJ12	—	
			DL05 PLCs				—	
			DL06 PLCs	Port 2 (HD15)			FA-15HD	
			D2-250-1 CPU					
			D2-260 CPU	Port 3 (25-pin)			FA-CABKIT	
			D4-450 CPU					
		P3-550 CPU	Port 2 (RJ12)	—				
		RS-485 Modbus RTU	DL06 PLCs	Port 2 (HD15)	SVC-485HD15-CBL-2	6-pin IEEE to HD15	—	
			D2-260 CPU				—	
			ZL-CDM-RJ12Xxx*	RJ12	SVC-485RJ12-CBL-2	6-pin IEEE to RJ12	—	
			USB-485M	RJ45	SVC-485CFG-CBL-2	6-pin IEEE to RJ45	—	
			Stellar (Soft Starter) SR44 Series	RJ45**	RS-485 Modbus RTU	DL06 PLCs	Port 2 (HD15)	SR44-485HD15-CBL-2
D2-250-1 CPU								
D2-260 CPU	RJ12	SR44-485RJ45-CBL-2				RJ45 to RJ12		
ZL-CDM-RJ12Xxx*								
SureStep	RJ12	RS-232 ASCII	DL06 PLCs	Port 2 (HD15)	STP-232HD15-CBL-2	HD15-pin to RJ12	—	
			D2-250-1 CPU				—	
			D2-260 CPU (Port2)	RJ12	STP-232RJ12-CBL-2	RJ12 to RJ12		
			DL05 PLCs					
			CLICK PLCs					

* When using the ZL-CDM-RJ12Xxx ZIPLink Communication Distribution Module, replace the lowercase xx with the number of RJ12 ports, i.e.4 for four ports or10 for ten ports. (ex: ZL-CDM-RJ12X4 or ZL-CDM-RJ12X10)

** The SR44-RS485 Communications Adapter must be installed for RS-485 communications with the Stellar soft starters.

Hitachi Drives Cross References

To find a suitable replacement for an SJ300 Hitachi drive, use the chart to the right to determine control mode(s) required, and the tables below to determine possible replacement part numbers. Suggested replacements do not necessarily have all control modes of the original, so appropriate drives will be application-dependent. Please call Tech Support if there are any replacement questions.

Drive Series	Volts/Hz	PID	Sensorless Vector	Full Flux Vector
L100	✓	✓		
SJ100	✓	✓	✓	
GS1	✓			
GS2	✓	✓		
DuraPulse (GS3)	✓	✓	✓	
SJ300	✓	✓	✓	✓

Hitachi SJ300 Cross Reference

Hitachi SJ300 AC Drives			Possible Replacements					
	Part No.	Horsepower	GS1	Price	GS2	Price	DuraPulse (GS3)	Price
	230V	SJ300-004LFU	0.5 hp	GS1-20P5	<--->	GS2-20P5	<--->	GS3-21P0 **
SJ300-007LFU		1.0 hp	GS1-21P0	<--->	GS2-21P0	<--->	GS3-21P0 *	<--->
SJ300-015LFU		2.0 hp	GS1-22P0 *	<--->	GS2-22P0	<--->	GS3-22P0 *	<--->
SJ300-022LFU		3.0 hp	-	-	GS2-23P0	<--->	GS3-23P0 *	<--->
SJ300-037LFU		5.0 hp	-	-	GS2-25P0 *	<--->	GS3-25P0 *	<--->
SJ300-055LFU		7.5 hp	-	-	GS2-27P5 *	<--->	GS3-27P5 *	<--->
SJ300-075LFU		10 hp	-	-	-	-	GS3-2010 *	<--->
SJ300-110LFU		15 hp	-	-	-	-	GS3-2015 *	<--->
SJ300-150LFU		20 hp	-	-	-	-	GS3-2020 *	<--->
SJ300-185LFU		25 hp	-	-	-	-	GS3-2025 *	<--->
SJ300-220LFU		30 hp	-	-	-	-	GS3-2030 *	<--->
460V	SJ300-007HFU	1.0 hp	-	-	GS2-41P0 *	<--->	GS3-41P0 *	<--->
	SJ300-015HFU	2.0 hp	-	-	GS2-42P0 *	<--->	GS3-42P0 *	<--->
	SJ300-022HFU	3.0 hp	-	-	GS2-43P0 *	<--->	GS3-43P0 *	<--->
	SJ300-040HFU	5.0 hp	-	-	GS2-45P0 *	<--->	GS3-45P0 *	<--->
	SJ300-055HFU	7.5 hp	-	-	GS2-47P5 *	<--->	GS3-47P5 *	<--->
	SJ300-075HFU	10 hp	-	-	GS2-4010 *	<--->	GS3-4010 *	<--->
	SJ300-110HFU	15 hp	-	-	-	-	GS3-4015 *	<--->
	SJ300-150HFU	20 hp	-	-	-	-	GS3-4020 *	<--->
	SJ300-185HFU	25 hp	-	-	-	-	GS3-4025 *	<--->
	SJ300-220HFU	30 hp	-	-	-	-	GS3-4030 *	<--->

Notes: Replacement drives do not necessarily have the same physical dimensions, mounting hole patterns or wiring terminal arrangements.

* = All SJ300 drives are specified for use with 3-phase power (but can be installed in single phase applications). GS drives in red require 3-phase power. Ensure the existing SJ application uses 3-phase input power, or that 3-phase power is available.

** = Replacement drive is higher horsepower than existing drive. Output power of new drive can be parameter-limited to the smaller horsepower.

Hitachi Drives Cross References

To find a suitable replacement for an L100 or SJ100 Hitachi drive, use the chart to the right to determine control mode(s) required, and the tables below to determine possible replacement part numbers. Suggested replacements do not necessarily have all control modes of the original, so appropriate drives will be application-dependent. Please call Tech Support if there are any replacement questions.

Drive Series	Volts/Hz	PID	Sensorless Vector	Full Flux Vector
L100	✓	✓		
SJ100	✓	✓	✓	
GS1	✓			
GS2	✓	✓		
DuraPulse	✓	✓	✓	
SJ300	✓	✓	✓	✓

Hitachi L100 Cross Reference

Hitachi L100 AC Drives			Possible Replacements					
	Part No.	Horsepower	GS1	Price	GS2	Price	DuraPulse	Price
230V	L100-002NFU	0.25 hp	GS1-20P2	<-->	GS2-20P5 **	<-->	GS3-21P0 * **	<-->
	L100-004NFU	0.5 hp	GS1-20P5	<-->	GS2-20P5	<-->	GS3-21P0 * **	<-->
	L100-007NFU	1.0 hp	GS1-21P0	<-->	GS2-21P0	<-->	GS3-21P0 *	<-->
	L100-015NFU	2.0 hp	GS1-22P0 *	<-->	GS2-22P0	<-->	GS3-22P0 *	<-->
	L100-022NFU	3.0 hp	-	-	GS2-23P0	<-->	GS3-23P0 *	<-->
	L100-037LFU	5.0 hp	-	-	GS2-25P0	<-->	GS3-25P0	<-->
	L100-055LFU	7.5 hp	-	-	GS2-27P5	<-->	GS3-27P5	<-->
	L100-075LFU	10 hp	-	-	-	-	GS3-2010	<-->
460V	L100-004HFU	0.5 hp	-	-	GS2-41P0 **	<-->	GS3-41P0 **	<-->
	L100-007HFU	1.0 hp	-	-	GS2-41P0	<-->	GS3-41P0	<-->
	L100-015HFU	2.0 hp	-	-	GS2-42P0	<-->	GS3-42P0	<-->
	L100-022HFU	3.0 hp	-	-	GS2-43P0	<-->	GS3-43P0	<-->
	L100-040HFU	5.0 hp	-	-	GS2-45P0	<-->	GS3-45P0	<-->
	L100-055HFU	7.5 hp	-	-	GS2-47P5	<-->	GS3-47P5	<-->
	L100-075HFU	10 hp	-	-	GS2-4010	<-->	GS3-4010	<-->

Notes: Replacement drives do not necessarily have the same physical dimensions, mounting hole patterns or wiring terminal arrangements.

* = Replacement drive requires 3-phase input power. Ensure the existing application uses 3-phase input power, or that 3-phase power is available.

** = Replacement drive is higher horsepower than existing drive. Output power of new drive can be parameter-limited to the smaller horsepower.

Hitachi SJ100 Cross Reference

Hitachi SJ100 AC Drives			Possible Replacements					
	Part No.	Horsepower	GS1	Price	GS2	Price	DuraPulse	Price
230V	SJ100-002NFU	0.25 hp	GS1-20P2	<-->	GS2-20P5 **	<-->	GS3-21P0 * **	<-->
	SJ100-004NFU	0.5 hp	GS1-20P5	<-->	GS2-20P5	<-->	GS3-21P0 * **	<-->
	SJ100-007NFU	1.0 hp	GS1-21P0	<-->	GS2-21P0	<-->	GS3-21P0 *	<-->
	SJ100-015NFU	2.0 hp	GS1-22P0	<-->	GS2-22P0	<-->	GS3-22P0 *	<-->
	SJ100-022NFU	3.0 hp	-	-	GS2-23P0	<-->	GS3-23P0 *	<-->
	SJ100-037LFU	5.0 hp	-	-	GS2-25P0	<-->	GS3-25P0	<-->
	SJ100-055LFU	7.5 hp	-	-	GS2-27P5	<-->	GS3-27P5	<-->
	SJ100-075LFU	10 hp	-	-	-	-	GS3-2010	<-->
460V	SJ100-004HFU	0.5 hp	-	-	GS2-41P0 **	<-->	GS3-41P0 **	<-->
	SJ100-007HFU	1.0 hp	-	-	GS2-41P0	<-->	GS3-41P0	<-->
	SJ100-015HFU	2.0 hp	-	-	GS2-42P0	<-->	GS3-42P0	<-->
	SJ100-022HFU	3.0 hp	-	-	GS2-43P0	<-->	GS3-43P0	<-->
	SJ100-040HFU	5.0 hp	-	-	GS2-45P0	<-->	GS3-45P0	<-->
	SJ100-055HFU	7.5 hp	-	-	GS2-47P5	<-->	GS3-47P5	<-->
	SJ100-075HFU	10 hp	-	-	GS2-4010	<-->	GS3-4010	<-->

Notes: Replacement drives do not necessarily have the same physical dimensions, mounting hole patterns or wiring terminal arrangements.

* = Replacement drive requires 3-phase input power. Ensure the existing application uses 3-phase input power, or that 3-phase power is available.

** = Replacement drive is higher horsepower than existing drive. Output power of new drive can be parameter-limited to the smaller horsepower.