

# GS/DURAPULSE Drives Accessories – Braking Units

## Overview



**BRAKING UNITS ARE AVAILABLE ONLY FOR DURAPULSE DRIVES.**

Braking units are applied to absorb the motor regeneration energy when the three-phase induction motor stops by deceleration.

GS-2DBU and GS-4DBU, used with GS series braking resistors, provide optimum braking performance.



To avoid injury or mechanical damage, please refer to user manual GS3-DB-M before wiring.



DURApulse AC Drive Braking Units									
AC Drive		Brake Unit			Braking Resistor			Braking Torque 10% Duty Cycle	Typical Thermal Overload Relay Value
Voltage	AC Drive Part No.	QTY	Brake Unit Part No.	Price	QTY	Resistor Part No.	Resistor Specification for Each Braking Unit		
230V	GS3-2020	1	GS-2DBU	<--->	1	GS-2020-BR-ENC	3000 W / 10Ω	125%	30A
	GS3-2025	1			1	GS-2025-BR-ENC	4800 W / 8Ω	125%	35A
	GS3-2030	1			1	GS-2030-BR-ENC	4800 W / 6.8Ω	125%	40A
	GS3-2040	2			2	GS-2040-BR-ENC	3000 W / 10Ω	125%	30A
	GS3-2050	2			2	GS-2050-BR-ENC	3000 W / 10Ω	100%	30A
460V	GS3-4020	1	GS-4DBU	<--->	1	GS-4020-BR-ENC	1500 W / 40Ω	125%	15A
	GS3-4025	1			1	GS-4025-BR-ENC	4800 W / 32Ω	125%	15A
	GS3-4030	1			1	GS-4030-BR-ENC	4800 W / 27.2Ω	125%	20A
	GS3-4040	1			1	GS-4040-BR-ENC	6000 W / 20Ω	125%	30A
	GS3-4050	1			1	GS-4050-BR-ENC	9600 W / 16Ω	125%	40A
	GS3-4060	1			1	GS-4060-BR-ENC	9600 W / 13.6Ω	125%	50A
	GS3-4075	2			2	GS-4075-BR-ENC	6000 W / 20Ω	125%	30A
	GS3-4100	2			2	GS-4100-BR-ENC	9600 W / 13.6Ω	125%	50A

# GS/DURAPULSE Drives Accessories – Braking Units

## Wiring Diagram (DURApulse only)

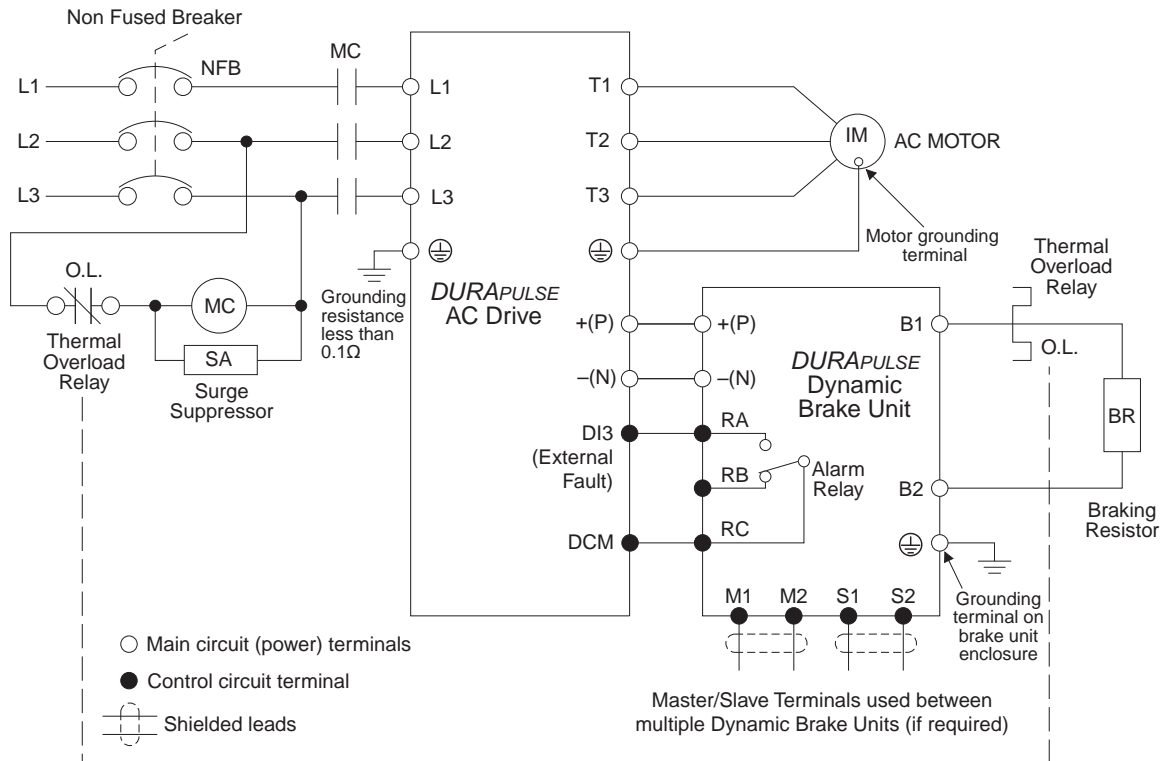

## Dimensions

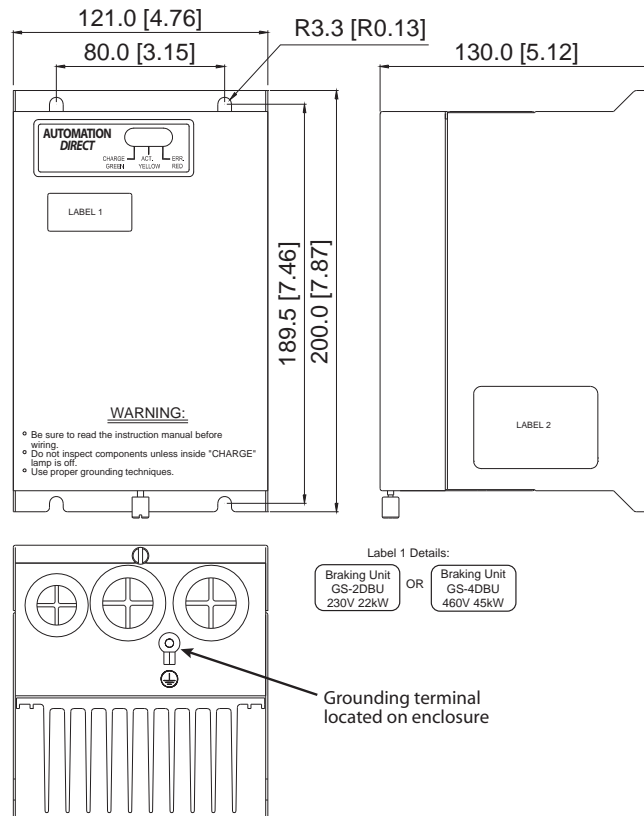

units: mm(in)

# GS/DURAPULSE Accessories – Overview

## Accessories – Part numbering system

**Note:** With the exception of the EMI filters, RF filters, and LR series line reactors, each accessory part number begins with GS, followed by the AC Drive rating, and then the relevant accessory code. Following the accessory code, you will find a description code when applicable. The diagram at right shows the accessory part numbering system.

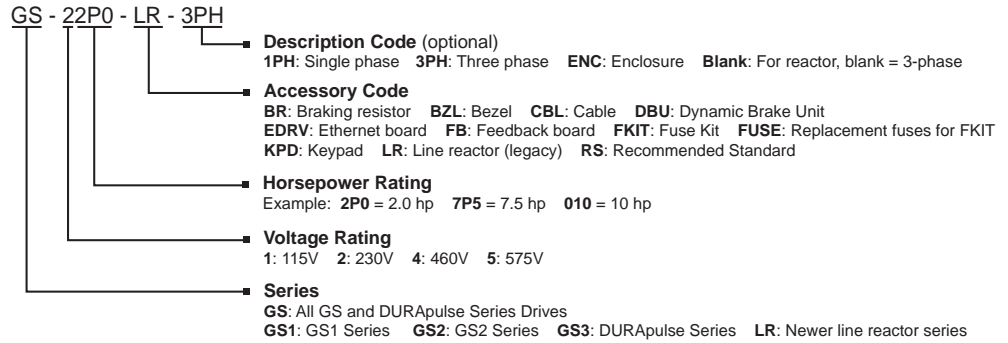

### Under 20hp

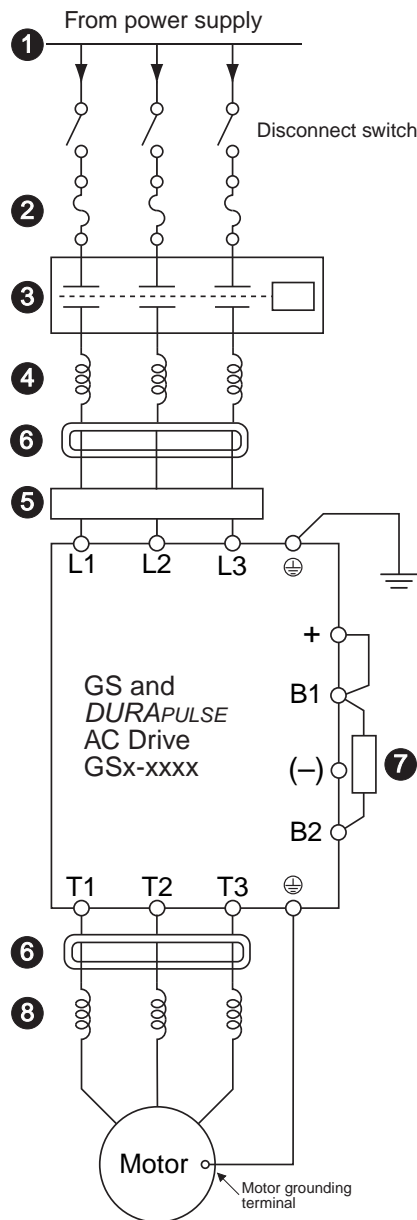

## 1 Power Supply

Please follow the specific power supply requirements shown in Chapter 1 and the Warning section of the applicable GS or DURAPULSE AC Drives User Manual.

## 2 Fuses (Refer to page 13–81.)

Input fuses protect the AC drive from excessive input current due to line surges, short circuits, and ground faults. They are recommended for all installations and may be required for UL-listed installations. (*AutomationDirect fuses are not available for GS1 drives.*)

## 3 Contactor (Optional) (Refer to the Motor Controls section.)

Do not use a contactor or disconnect switch for run/stop control of the AC drive and motor. This will reduce the operating life cycle of the AC drive. Cycling a power circuit switching device while the AC drive is in run mode should be done only in emergency situations.

## 4 Input Line Reactor (Optional) (Refer to page 13–50.)

Input line reactors protect the AC drive from transient overvoltage conditions, typically caused by utility capacitor switching. The input line reactor also reduces the harmonics associated with AC drives. Input line reactors are recommended for all installations.

## 5 EMI filter (Optional) (Refer to page 13–74.)

Input EMI filters reduce electromagnetic interference or noise on the input side of the AC drive. They are required for CE compliance and recommended for installations prone to or sensitive to electromagnetic interference. (*Separate EMI filters are not necessary for GS1 drives.*)

## 6 RF filter (Optional) (Refer to page 13–80.)

RF filters reduce the radio frequency interference or noise on the input or output side of the inverter.

## 7 Braking Resistor (Optional) (Refer to page 13–69.)

Dynamic braking allows the AC drive to produce additional braking (stopping) torque. AC drives can typically produce between 15% & 20% braking torque without the addition of any external components. The addition of optional braking may be required for applications that require rapid deceleration or high inertia loads. (*Braking resistors are not available for GS1 drives.*)

## 8 Output Line Reactor (Optional) (Refer to page 13–50.)

Output line reactors protect the motor insulation against AC drive short circuits and IGBT reflective wave damage, and also “smooth” the motor current waveform, allowing the motor to run cooler. They are recommended for operating “non-inverter-duty” motors and when the length of wiring between the AC drive and motor exceeds 75 feet.

# GS/DURAPULSE Accessories – Overview

20hp & Over  
(DURAPULSE only)

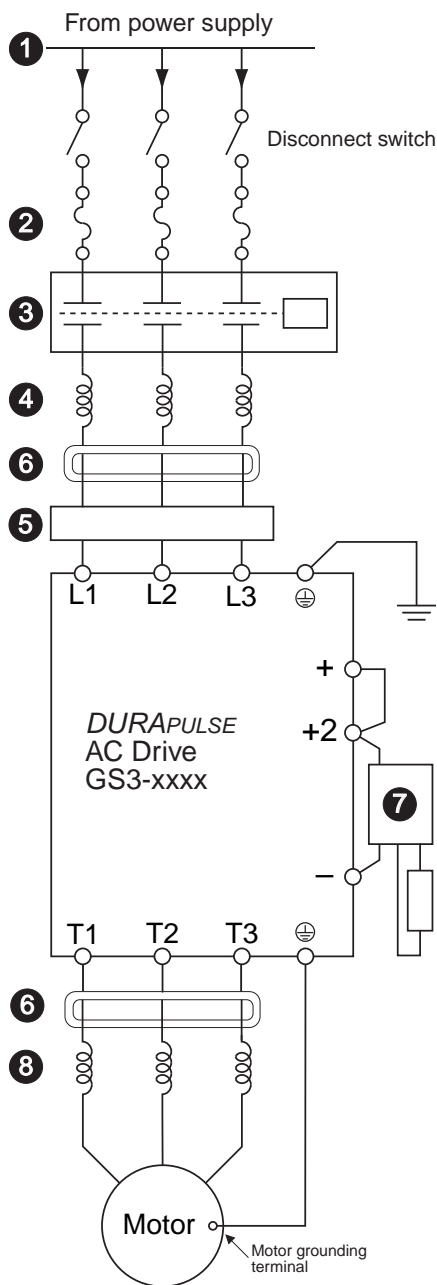

## 1 Power Supply

Please follow the specific power supply requirements shown in Chapter 1 of the DURAPULSE AC Drives User Manual.

## 2 Fuses (Refer to page 13–81.)

Input fuses protect the AC drive from excessive input current due to line surges, short circuits, and ground faults. They are recommended for all installations and may be required for UL-listed installations.

## 3 Contactor (Optional) (Refer to the Motor Controls section.)

Do not use a contactor or disconnect switch for run/stop control of the AC drive and motor. This will reduce the operating life cycle of the AC drive. Cycling a power circuit switching device while the AC drive is in run mode should be done only in emergency situations.

## 4 Input Line Reactor (Optional) (Refer to page 13–50.)

Input line reactors protect the AC drive from transient overvoltage conditions, typically caused by utility capacitor switching. The input line reactor also reduces the harmonics associated with AC drives. Input line reactors are recommended for all installations.

## 5 EMI filter (Optional) (Refer to page 13–74.)

Input EMI filters reduce electromagnetic interference or noise on the input side of the AC drive. They are required for CE compliance and recommended for installations prone to or sensitive to electromagnetic interference.

## 6 RF filter (Optional) (Refer to page 13–80.)

RF filters reduce the radio frequency interference or noise on the input or output side of the inverter.

## 7 Braking Unit & Braking Resistor (Optional) (pg 13–67)

Dynamic braking allows the AC drive to produce additional braking (stopping) torque. AC drives can typically produce between 15% & 20% braking torque without the addition of any external components. The addition of optional braking may be required for applications that require rapid deceleration or high inertia loads.

## 8 Output Line Reactor (Optional) (Refer to page 13–50.)

Output line reactors protect the motor insulation against AC drive short circuits and IGBT reflective wave damage, and also “smooth” the motor current waveform, allowing the motor to run cooler. They are **recommended for operating “non-inverter-duty” motors** and when the **length of wiring between the AC drive and motor exceeds 75 feet.**